

Gavrilovic S. Branislav *

SIMULATION OF TORSION MOMENT AT THE WHEEL SET OF THE RAILWAY VEHICLE WITH THE TRACTION ELECTROMOTOR FOR WAVY DIRECT CURRENT

The phenomenon of mechanical resonance in the axial make of the railway vehicle with the traction electromotors for wavy direct current has been of topical interest for the railway connoisseurs for a long time. This is not randomly because mechanical resonance may cause crevices and fractures in the wheel set. Accordingly mechanical resonance may endanger safety of railway communication. However, previous research did not precisely investigate the influence of tension and current at the value and guise of torsion moment at the wheel set. Therefore, this paper defined adduced influence. Besides, this paper defined the optimal antislippage shield for all the railway vehicles with the traction electromotors for wavy direct current.

1. Introduction

Within the capital reparation of the diode ZS 441 series locomotives in 2006 and 2007, the modification of electric devices was realised. The modification of the diode ZS 441 series locomotives was realised at the electric devices because the Directorate of

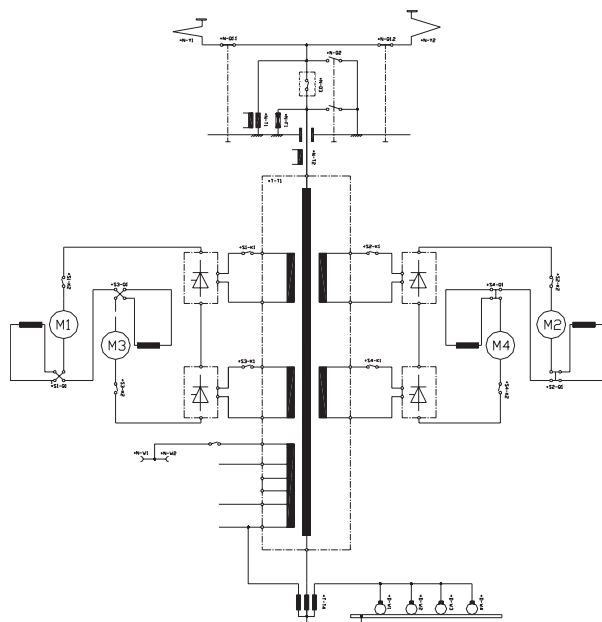

Fig. 1 Simplified traction circuit of the thyristor ZS 444 series locomotives

»Serbian Railway« wanted a greater reliability in service and better environment for the railway motorman. In the modification the hightension tuner was ejected because the diode bridge was replaced with the halfconduct tiristore bridge. The traction circuit of the thyristor ZS 444 series locomotives was realised with two bimotor units. The first and the second bimotor unit comprised M1 and M3 and M2 and M4 traction electromotors for wavy direct current at the separate rotary socle. Accordingly, all wheel sets of the ZS 444 series locomotives have got the equal performance. Traction electromotors for wavy direct current in each bimotor unit are connected in a series - Fig. 1.

For the purpose of a precise analysis of the influence of wavy direct current on the value and guise of torsion moment at the wheel set we apply the operational method based on Laplace's transformation. This method will be described in the subsequent article.

2. Dynamics at the Wheel set of the Thyristor ZS 444 Series Locomotives

The propulsion system of the thyristor ZS 444 series locomotives is a mechanical system which comprises the traction electromotor for wavy direct current (3), a cogged clamp (2), a cardan shaft (5), a rubber clamp, a reductor (1), the driving shaft (4) and a monoblock wheel (Fig. 2) [1, 2].

The essential running of the mechanical system is a rotation with a transfer of operative moment from the shaft of the traction electromotor to the monoblock wheel. Researches have shown that the described mechanical system may generate a strong torsion oscillation and fracture of the wheel set [1, 2].

* Gavrilovic S. Branislav
Railway College, Belgrade, Serbia, E-mail: brane23@sbb.co.yu

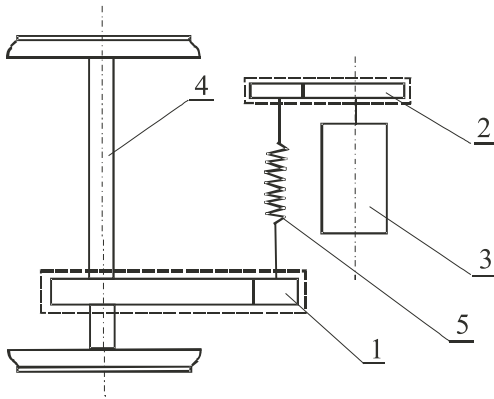

Fig. 2 Propulsion system of the thyristor ZS 444 series locomotives

The dynamic balance of the shaft of the traction electromotor for wavy direct current is described by the next equation [1, 2, 3]:

$$J_m \frac{d\omega}{dt} = M - M_m \quad (1)$$

where J_m is the inertial moment of rotating mass with the angular speediness ω . The inertial moment J_m is a sum of inertial moment of the traction electromotor for wavy direct current (550 Nms^2), inertial moment of the cogged clamp (2 Nms^2), inertial moment of the cardan shaft (3 Nms^2), inertial moment of the rubber clamp (10 Nms^2) and inertial moment of the lesser gear of the jagged reductor (10 Nms^2). Therefore, the inertial moment is $J_m = 575 \text{ Nms}^2$ [3]; ω - angular speediness of the shaft of the traction electromotor for wavy direct current; $M(t)$ - transient value of torque at the shaft of the traction electromotor for wavy direct current; $M_m(t)$ - transient value of torque oncoming from idler force; D - diameter of the monoblock wheel ($D = 1210 \text{ mm}$); i - transfer ratio of the jagged reductor ($i = 3.65$).

Fig. 3 shows the courses of the operative moment M_0 and the torque M_v of the reaction force

$\vec{F}_v (\vec{F}_v = -\vec{F}_v')$. J_0 in Fig. 3 denominates the inertial moment of rotating mass with the angular speediness ω_0 . The inertial moment J_0 is the sum of inertial moment of the larger gear of the jagged reductor (180 Nms^2); inertial moment of the driving shaft (340 Nms^2) and inertial moment of the monoblock wheel (1600 Nms^2). The total inertial moment is $J_0 = 2120 \text{ Nms}^2$ [3].

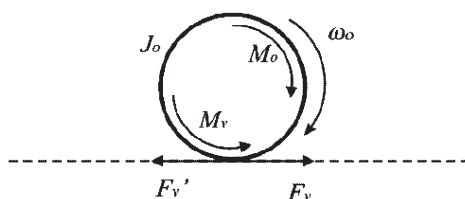

Fig. 3 Courses of the operative moments M_0 and the torque M_v

The equation of dynamic balance for the shown system in Fig. 3 is:

$$J_0 \frac{d\omega_0}{dt} = M_0 - M_v \quad (2)$$

where

$$\omega_0 = \frac{2}{D} \cdot v = \frac{\omega}{i} \quad (3)$$

$$M_0 = \eta \cdot i \cdot M_m \quad (4)$$

$$M_v = \frac{D}{2} \cdot F_v \quad (5)$$

$\eta = 0.975$ (grade of utility according to the IEC - 349)

Based on equations (1) and (4):

$$J_m \frac{d\omega^*}{dt} = \frac{M_m}{\omega_n} (M^* - M_0^*) \quad (6)$$

where $M_{0b} = M_{0n} = \eta \cdot i \cdot M_m = 27924.8849 \text{ Nm}$

Based on equations (2) and (5):

$$J_m \frac{d\omega_0}{dt} = M_0 - \frac{D}{2} \cdot F_v \quad (7)$$

The equation of the mechanical system running is:

$$m \frac{dv}{dt} = F_v - \Sigma F_{ot} \quad (8)$$

where: m - mass of each wheel set; ΣF_{ot} - total reaction forces (ΣF_{ot} is the sum of friction force of the wheel-rail system; friction force in a shaft bolster; friction force of air; reaction force on a slope; reaction force on a curvature and reaction force of inertia of locomotive).

Based on the former equations:

$$\left(J_0 + m \cdot \left(\frac{D}{2} \right)^2 \right) \frac{d\omega_0^*}{dt} = \frac{M_{0n}}{\omega_{0n}} (M_0^* - M_{Fv}^*) \quad (9)$$

where: $\omega_{0n} = \frac{\omega_n}{i} = 35.8438 \frac{\text{rad}}{\text{s}}$; $M_{Fv}^* = \frac{D}{2} \frac{\Sigma F_{ot}}{M_{0n}}$ - comparative value of the reaction momentum.

Based on the equations (6) and (9), the angular speedinesses ω and ω_0 have got forms in the complex domain:

$$\omega = \frac{M_m \cdot (M^* - M_0^*)}{J_m \cdot \omega_n \cdot s} \quad (10)$$

$$\omega_0 = \frac{M_{0n} (M_0^* - M_{Fv}^*)}{\left(J_0 + m \left(\frac{D}{2} \right)^2 \right) \cdot \omega_{0n} \cdot s} \quad (11)$$

The torsion moment of the driving shaft (4) - Fig. 2:

$$M_r = k \cdot \Delta\theta \quad (12)$$

$$\Delta\theta = \frac{1}{i}\theta - \theta_0 \quad (13)$$

$$\omega_0 = \frac{d\theta_0}{dt} \text{ in the complex domain } \theta_0 = \frac{\omega_0}{s} \quad (14)$$

$$\omega = \frac{d\theta}{dt} \text{ in the complex domain } \theta = \frac{\omega}{s} \quad (15)$$

where k - torsion constant of driving shaft (4) - Fig. 2. The torsion constant of the leaves part of the driving shaft (i.e. part of the driving shaft from the jagged reductor to the near monoblock wheel) is $k_1 = 553 \cdot 10^6 \text{ Nm} \cdot \text{rad}^{-1}$. Torsion constant of the longer part of the driving shaft (i.e. part of the driving shaft from the jagged reductor to the further monoblock wheel) is $k_2 = 9.8 \cdot 10^6 \text{ Nm} \cdot \text{rad}^{-1}$ [3]; θ_0 - banking of driving shaft (4) induced by the wheel-rail system.

3. Resonance Frequency of the wheel set

As

$$\theta_0 = \frac{\frac{k}{i}}{\left(J_0 + m \cdot \left(\frac{D}{2}\right)^2\right) \cdot s^2 + k} \quad (16)$$

transfer function W_M is:

$$W_r = \frac{M_r}{M} = \frac{1}{\left(J_m \cdot k + \frac{k}{\eta \cdot i^2} \left(J_0 + m \cdot \left(\frac{D}{2}\right)^2\right)\right) \cdot s^2} \cdot \frac{\frac{k}{i} \left(J_0 + m \cdot \left(\frac{D}{2}\right)^2\right) \cdot s^2}{\left(\frac{J_m \cdot \left(J_0 + m \cdot \left(\frac{D}{2}\right)^2\right)}{J_m \cdot k + \frac{k}{\eta \cdot i^2} \left(J_0 + m \cdot \left(\frac{D}{2}\right)^2\right)} \cdot s^2 + 1 \right)} \quad (17)$$

The dominant poles of the transfer function W_M define the resonance frequency of the wheel set. The resonance frequency of the wheel set is determined by the next equation:

$$\omega = \sqrt{\frac{J_m \cdot k + \frac{k}{\eta \cdot i^2} \left(J_0 + m \cdot \left(\frac{D}{2}\right)^2\right)}{J_m \cdot \left(J_0 + m \cdot \left(\frac{D}{2}\right)^2\right)}} \quad (18)$$

Based on the equation (18), resonance frequencies of the leaves and longer of the driving shaft (4) - Fig. 2 - are:

$$\omega_1 = 526.87 \frac{\text{rad}}{\text{s}} \quad (19)$$

$$\omega_2 = 70.14 \frac{\text{rad}}{\text{sec}} \quad (20)$$

4. Torsion moment at a Slippage of the Wheel set

Based on the former equations, we made a program in MATLAB-SIMULINK to simulate the torsion moment at the wheel set. We received a chronological variety of the torsion moment of the longer part of the driving shaft according to Fig. 4 when we started from this simulation program. We assumed that a slippage of the wheel set appeared because of a nuisance value of the traction

coefficient at $M_{F_{vs}} = \frac{D}{2} \sum F_{ot} = 1$ (The traction coefficient at

this environment is defined by the following term: $F_v > \mu \cdot Q_c \implies$

$$\mu < \frac{M_{0n}}{\frac{D}{2} \cdot Q_c} = \frac{27924.8849}{\frac{1.21}{2} \cdot 200000} = 0.23).$$

We also assumed that the rotating moment of the shaft of the traction electromotor for wavy direct current is determined by:

$$M(t) = \frac{33}{32} \cdot k_0 \cdot I_{sr}^2 \left(1 + \frac{16}{33} \cos 2\omega t + \frac{1}{33} \cos 4\omega t\right) = (21)$$

$$= M_{sr} (1 + a_1 \cos 2\omega t + a_2 \cos 4\omega t)$$

where M_{sr} - in between value of the torque of the shaft of the traction electromotor for wavy direct current; $a_1 = 16/33$ - factor amplitude of a frequency $2f = 2 \cdot 50 = 100 \text{ Hz}$; $a_2 = 1/33$ - factor amplitude of a frequency $4f = 4 \cdot 50 = 200 \text{ Hz}$.

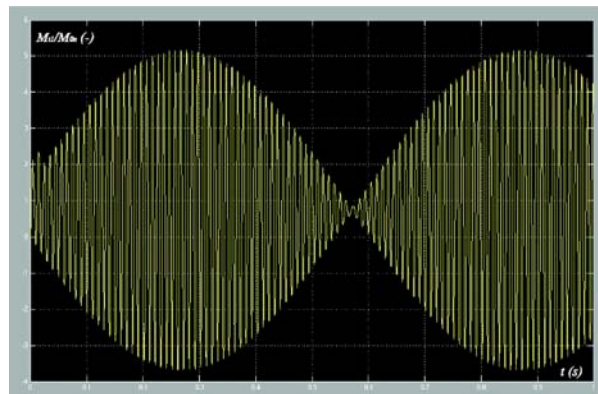

Fig. 4 Comparative value of the torsion moment of the longer part of the driving shaft at $a_1 = 16/33$ of a frequency during $2f = 2 \cdot 50 = 100 \text{ Hz}$ the slippage of the wheel set

Based on Fig. 4, we can conclude that the torsion moment of the longer part of the driving shaft quite quickly rises during the slippage of the wheel set. This moment achieved the value of $M_{r1}/M_{0n} = 23$ ($M_{r1} = 6.42$ MNm) in a quite short period of $t \leq 0.3$ s. Consequently, the torsion moment during the slippage of the wheel set will permanently impair the longer part of the driving shaft.

If we curtail the value of the factor amplitude of a frequency $2f = 2 \cdot 50 = 100$ Hz from $a_1 = 16/33$ to $a_1 = 0.1$, the dependence $M_{r1}/M_{0n} = f(t)$ during the slippage of the wheel set will be according to Fig. 5. (The factor amplitude a_1 may dwindle if we enlarge inductance of central silencer).

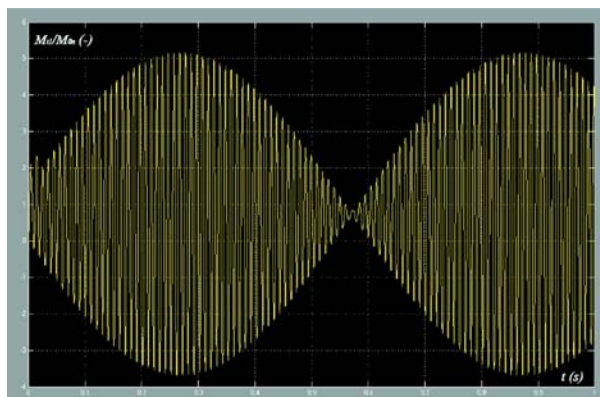

Fig. 5 Comparative value of the torsion moment of the longer part of the driving shaft at $a_1 = 0.1$ of a frequency $2f = 2 \cdot 50 = 100$ Hz during the slippage of the wheel set

Based on Fig 5, we can conclude that the torsion moment at $a_1 = 16/33$ is five times smaller than the torsion moment $a_1 = 0.1$ at during the slippage of the driving wheel set. The peak value of the torsion moment of the longer part of the driving shaft at $a_1 = 0.1$ is attained in $t = 0.25$ s. Besides, our program for simulation showed that the peak value of this moment further dwindled while we were further dwindling the factor amplitude of a circular frequency $2f = 2 \cdot 50 = 100$ Hz.

If we commute the diode or asymmetrical thyristor rectifier with the symmetrical thyristor rectifier, we'll receive a passable value of the torsion moment with the frequency $2f = 2 \cdot 25 = 50$ Hz. The dependence $M_{r1}/M_{0n} = f(t)$ during the slippage of the wheel set with the frequency $2f = 2 \cdot 25 = 50$ Hz and $a_1 = 3$ is shown in Fig. 6.

Based on Fig. 6, we can conclude that the substitution of the diode rectifier or the asymmetrical with modern symmetrical thyristor rectifier relates to a passable value of the torsion moment during the slippage of the wheel set. Besides, this substitution will

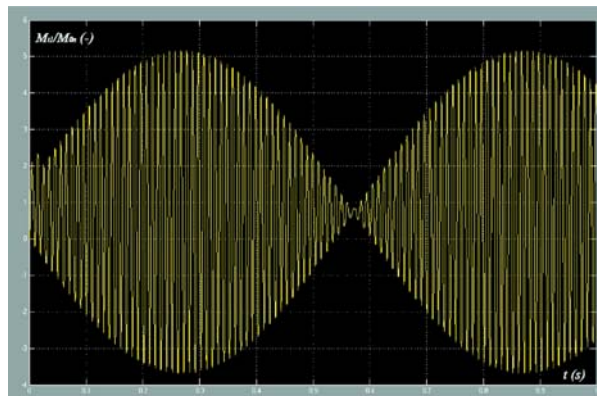

Fig. 6 Comparative value of the torsion moment of the longer part of the driving shaft at $a_1 = 3$ of a frequency $2f = 2 \cdot 25 = 50$ Hz during the slippage of the wheel set

eject the cascade switch and simplify the traction transformer. This substitute may also enable the application of recuperative brake. Consequently, we believe that the modern symmetrical thyristor rectifier may eliminate the impairing of the longer part of the driving shaft during the slippage. With this rectifier the existing antislippage shield of the ZS 441, ZS 461 and ZS 444 electrolocomotives will be enough speedy though now it is not.

5. Conclusion

The torsion moment of the longer part of the driving shaft rises quite quickly during the slippage of the wheel set. This moment was achieving the value of $M_{r1}/M_{0n} = 23$ ($M_{r1} = 6.42$ MNm) in quite a short period of $t \leq 0.3$ s. Consequently, torsion moment during the slippage of the wheel set will permanently impair the longer part of the driving shaft.

The torsion moment of the longer part of the driving shaft at $a_1 = 16/33$ is five times smaller than the torsion moment at $a_1 = 0.1$ during the slippage of the wheel set. The peak value of the torsion moment of the longer part of the driving shaft at $a_1 = 0.1$ is attained in $t = 0.25$ s. Besides, our program for simulation showed that the peak value of this moment further dwindled while we were further dwindling the factor amplitude of a frequency $2f = 2 \cdot 50 = 100$ Hz.

The substitution of the diode rectifier or the asymmetrical with modern symmetrical thyristor rectifier relates to a passable value of the torsion moment with the frequency $2 \cdot f = 2 \cdot 25 = 50$ Hz during the slippage of the wheel set. Besides, this substitution will eject the cascade switch and simplify the traction transformer. This substitution may also enable the application of recuperative brake. Consequently, we believe that the modern symmetrical thyristor rectifier may eliminate the impairing of the longer part of the driving shaft during the slippage.

References

- [1] JOVANOVIĆ, R.: *Tension status of locomotive shaft in exploitation situation*, PhD dissertation, Mechanical Engineering Faculty, Belgrade, 1978.
- [2] JOVANOVIĆ, R.: *Causes, appearances and odds eliminating some splits and mishaps of the operative shaft (axle) of the rail vehicles*, Research project MIN, Institution „Edvard Kardelj“, Nis, 1987.
- [3] JANJANIN, S.: *Identification of some reasons for torsional moment of the operative system of 441 locomotive with the analogue computer*, The Community of Yugoslav Railways, Study, Zagreb, 1974.
- [4] GAVRILOVIĆ, S. B.: *Motivity moment of the traction electromotor of the thyristoring JZ 444 series locomotives*, Proc. of 5th Intern. Scientific Conference on Production Engineering, pp. 553–558, ISBN 99589262-0-2, Bihac, BIH, 2005.