

Oleksij Fomin - Juraj Gerlici - Alyona Lovska - Kateryna Kravchenko
Pavlo Prokopenko - Anna Fomina - Vladimir Hauser*

DURABILITY DETERMINATION OF THE BEARING STRUCTURE OF AN OPEN FREIGHT WAGON BODY MADE OF ROUND PIPES DURING ITS TRANSPORTATION ON THE RAILWAY FERRY

In order to reduce the cost of designing and manufacturing of the new-generation open wagons, it is proposed to construct their carrying systems from round pipes. In order to exploit the proposed designs of wagons in international rail-water communication, it is assumed that they will be equipped with assemblies for fastening of chain binders. The maximal values of accelerations, as components of dynamic load acting on open wagons, made from round pipes during their transportation on a railway ferry, are determined. It is established that when moving the body in the vertical direction for a wagon located on the upper deck, the maximum acceleration value is 0.84 g, with angular displacement relative to the transverse axis for the extreme from the anchor point of the wagon body - is 0.1 g, with angular displacement around the longitudinal axis for the extreme from the bulwark of the body of the wagon - is 0.24 g. The conducted researches will enable increased efficiency of operation of open wagons through international transport corridors.

Keywords: open freight wagon, bearing structure, strength, loading, rail-ferry transportation

1. Introduction

The increased rates of cargo transportation across the territory of Ukraine, which is a link of the more important transport corridors between Europe and Asia, call for introduction of the new designs of wagons, with improved technical and operational parameters. It is known that one of the most demanded types of cars is an open wagon. In order to increase the efficiency of the open wagon operation and reduce the cost of their production, it is necessary to find new alternative solutions for their design while ensuring the conditions of durability and operational reliability [1-4].

2. Analysis of recent research

The research work of the Omsk State Technical University (Omsk) is devoted to the study of the strength of the open wagons' bodies, made of aluminium alloys, taking into account the physical nonlinearity of the material. In this case, a generalized method of forces [5] is used. However, attention was not paid to determination of stresses in the elements of the body of an open wagon, during its transportation on a railway ferry.

The question of the possibility of the service life extension of an open car in operation is considered [6]. The method of technical diagnostics of open wagons is developed, based on which it is proposed to determine the final service life of open wagons based on calculations of strength, stability and remaining life.

It should be noted that the finite element model of the open wagon, presented in [6] did not take into account the possibility of applying the loads acting on it through means of fastening, relative to the decks of the railway ferries. Recommendations on use of the software for assessing the performance of railway transport facilities are given in [7]. Due to the fact that, when using of modern methods for strength analysis, there is no recommendation on the required degree of discretization of certain objects' zones, development of the new methods for calculation and results analysis is proposed.

Investigations on the optimization of bodies of open wagons are given in [8]. The corrected analysis of the stressed state and the structural and parametric optimization of the side walls and frames of the wagons were made in his work. A modified plate-rod model is proposed for calculation of the stresses in the body.

It is important to note that in the calculation schemes of wagon bodies author did not take into account the efforts that will act on the body during its carriage on railway ferries.

Promising ways to improve the technical and economic indexes of freight wagons and the direction to improve their dynamic properties by introducing elastic damping elements are considered in [9]. The study of the strength of improved structures of the freight wagons bodies, during their transportation on a railway ferry, is not carried out.

Measures to improve the bearing structure of the open car body in order to ensure the reliability of its attachment on the deck of the railway ferry are given in [10]. The results of the strength calculations of the body, taking into account its fixing against the deck on the proposed structural units at the

* ¹Oleksij Fomin, ²Juraj Gerlici, ³Alyona Lovska, ⁵Kateryna Kravchenko, ⁴Pavlo Prokopenko, ⁵Anna Fomina, ²Vladimir Hauser

¹Department of Cars and Carriage Facilities, State University of Infrastructure and Technology, Ukraine

²Department of Transport and Handling Machines, Faculty of Mechanical Engineering, University of Zilina, Slovakia

³Department of Cars, Ukrainian State University of Railway Transport, Ukraine

⁴Branch Research and design and technological Institute of Railway Transport "PJSC Ukrzaliznytsya", Ukraine

⁵Department of railway, road transport and handling machines, Volodymyr Dahl East Ukrainian National University, Ukraine

E-mail: fominaleksejviktovic@gmail.com

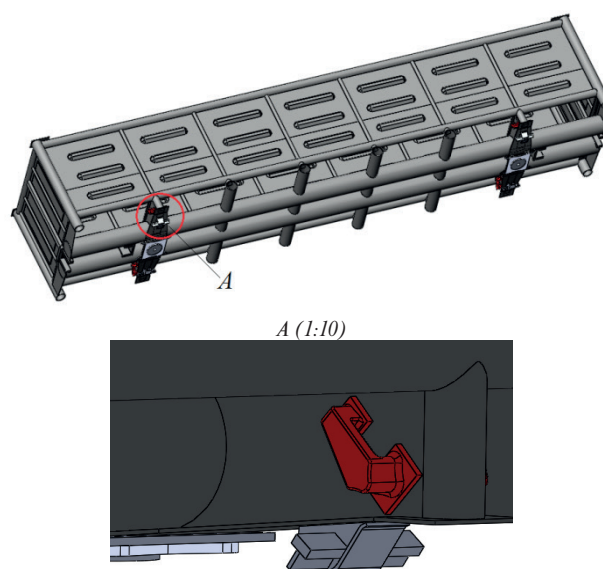

Figure 1 The open wagon of an improved design with assemblies for railroad decks

balancing of the railway ferry, have been made. It was concluded that the proposed solutions are feasible. There is no research on optimizing the performance of the carrying structure of the open wagon in operation.

The research of dynamics of a railway wagon with an open loading platform is given in [11]. The calculation is carried out in the software MSC Adams. Investigation of stability against the swinging over the wagon was carried out when it is entered into a curve with a radius of 250 m, taking into account different speeds of motion.

The issue of the rolling stock design, for the transportation of heavy goods is considered in [12]. Research of dynamics and durability was carried out with the help of modern softwares ProMechanica and CosmosWorks. When designing the carrying structure of the conveyor, a study on the possibility of its build from various types of materials was conducted.

The structural features of the wagon for intermodal transportation are discussed in [13]. The wagon has an undersized middle part and the presence of the carriage assembly makes it possible to load/unload the vehicle on/off by its own weight.

The results of studies to determine the nature and extent of impact of different freight bogies on the strength of the carrying systems of wagons are considered in [14]. The question of determining the parameters of the bearing structures of wagons bodies' durability, during their transportation on railway ferries, was not investigated in the considered works.

The features of theoretical and experimental studies on implementation of the bond joint of the back-frame of wagon for pellet transportation are considered in [15]. The obtained results confirm the constructive efficiency of the bond joint of the back-frame of wagons for pellet transportation during the established fifteen-year service life.

The rationale for extending the service life of open wagons that have exhausted their standard service life is carried out in [16]. To determine the dynamic loading of the open car body during a shunting, a mathematical model was made, the results of which were taken into account in the study of the strength of

the open car body, taking into account the operational wearing of structural elements.

Features of creation of a promising concept of a coupling gear of open cars are given in [17]. To substantiate the use of the proposed concept, mathematical and computer modeling of the loading of the open car body during a shunting was carried out.

The task of determining the strength factors of the car body elements during its transportation on the railway ferry is not set in these works.

The purpose of the article is explanation of features of the stability factors definition of an open wagon body bearing structure, made from of pipes, during its transportation on a railway ferry.

3. The main content

In order to reduce the material capacity of the bearing structures of the open wagon bodies, providing the conditions of strength and operational reliability, it is suggested and scientifically based use of round pipes as elements of their bearing systems.

For the possibility of transportation of an open wagon on a railway ferry, it is proposed to install components for fastening of chain ties on its centre pin bolster (Figure 1) [10].

In order to determine the dynamic load that acts on the carrying structure of the open wagon body when being transported on a railway ferry, the mathematical model, presented in [18], is used. The model takes into account the movement of the wagon in the main types of fluctuations of the railway ferry - translational movement relative to the vertical axis (1), angular displacement around the transverse axis (2), angular displacement around the longitudinal axis (3):

$$D' \cdot \ddot{q}_1 + A_z \cdot \dot{q}_1 = A_z \cdot \dot{F}(t); \quad (1)$$

$$I_\varphi \cdot \ddot{q}_2 + \left(A_\varphi \cdot \frac{L}{2} \right) \dot{q}_2 = p' \cdot \frac{h}{2} + A_\varphi \cdot \frac{L}{2} \cdot \dot{F}(t); \quad (2)$$

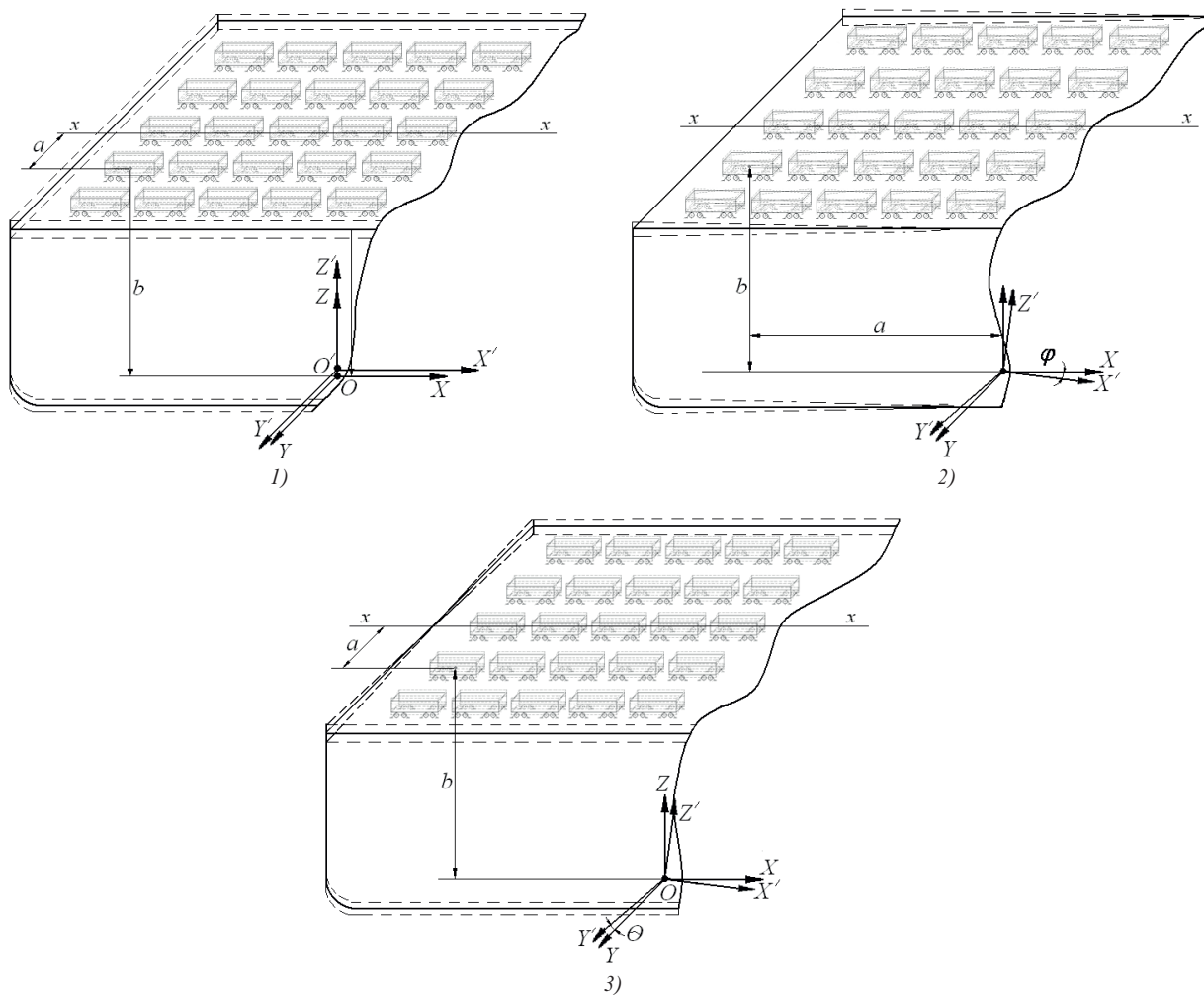

Figure 2 Movement of the body of the wagon with fluctuations in the railway ferry: 1 - in the vertical direction; 2 - around the transverse axis; 3 - around the longitudinal axis

$$I_{\theta} \cdot \ddot{q}_3 + \left(\Lambda_{\theta} \cdot \frac{B}{2} \right) \dot{q}_3 = p' \cdot \frac{h}{2} + \Lambda_{\theta} \cdot \frac{B}{2} \cdot \dot{F}(t); \quad (3)$$

where $q_1 = z$, $q_2 = \varphi$, $q_3 = \theta$ are generalized coordinates corresponding to:

- z - the displacement of the body relative to the vertical axis passing through its center of gravity,
- φ - the angular displacement around the transverse axis,
- θ - the angular displacement around the longitudinal axis.

The origin of the coordinate system is located at the center of gravity of the railway ferry;

- D' - massive water repression,
- L, B - respectively, the length and width of the railway ferry,
- h - the height of the board of the railway ferry,
- Λ_i - coefficient of resistance fluctuations,
- p' - wind load,
- I_{φ}, I_{θ} - a moment of inertia of the railway ferry with cars placed on decks with pitching and rolling, respectively,

$F(t)$ - the law of a force variation that disturbs the movement of a railway ferry with the bodies of cars located on its decks.

The diagrams of movements of the wagon body fixed to the deck of the railway ferry are shown in Figure 2.

When compiling the mathematical model it is taken into account that the wagon body is rigidly fixed relative to the deck

and moves with it. The impact of sea waves on the body of a railway ferry, with wagons placed on its deck, was not taken into account.

The input parameters of the mathematical model are: geometrical characteristics of the railway ferry, hydro-meteorological characteristics of the navigation waters, coordinates of the placement of wagon bodies on the decks of the railway ferry.

The research for the transportation of wagons on the ferry "Heroes of Shipka" in the Black Sea area was conducted.

To solve the differential equations of the body of the wagon, a calculation program was compiled in the medium of the Mathcad package [19-20], for which they were reduced to the normal form of the Cauchy and then integrated into the Runge-Kutta method.

The numerical values of the maximum accelerations, acting on the body of wagons located relative to the decks of the railway ferry, were as follows: when moving the body in the vertical direction for the wagon, placed on the upper deck - 0.84g, with the angular displacement relative to the transverse axis for the extreme from the anchors of the body of the wagon - 0.1g, with angular displacement around the longitudinal axis for the extreme from the bulwark body of the wagon - 0.24g.

The conducted numerical values of accelerations, as components of the dynamic load acting on the body of the wagon

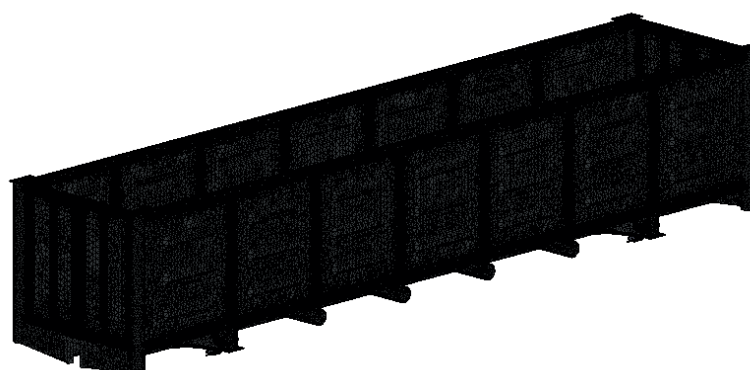

Figure 3 Finite-element model of the body of the open wagon

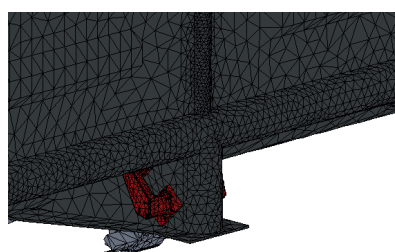

Figure 4 Fragment of the finite-element model of the open wagon body in the zone of placement of the unit for fastening the chain tie

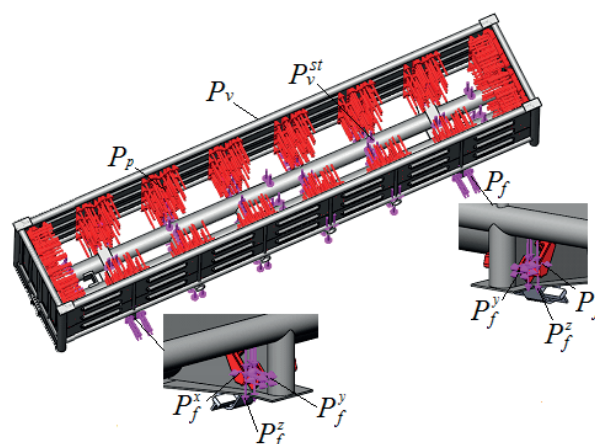

Figure 5 Model of the body of the open wagon strength

Table 1 Strength factors of the bearing structure of the open wagon body during its transportation on the railway ferry

Strength indicator	Movement type		
	Moving relative to the vertical axis	Angles relative to the transverse axis	Angles relative to the longitudinal axis
Stresses, MPa	208.3	227.5	293.1
Moving in construction knots, mm	9.76	9.97	15.6
Equivalent deformation	$2.25 \cdot 10^{-3}$	$2.2 \cdot 10^{-3}$	$2.5 \cdot 10^{-3}$

when transported on a railway ferry, are taken into account in its strength analysis. The strength test was conducted using the finite element method in the CosmosWorks software.

Finite element model of the body of the open wagon is given in Figures 3, 4. Due to the fact that the hatch covers are not tightly attached to the body frame, but hingedly and perform the function of the elements transmitting the load on the rigidly connected elements of the frame, they were not taken into account in the strength model.

When creating a finite element model, isoparametric tetrahedra were used, the optimal number of which was determined by the graph-analytical method. The number of elements of the grid was 717728, the number of nodes 227767, the maximum dimension of the element 85 mm, the minimum dimension 17 mm, the maximum aspect ratio of the elements was 985.34, the percentage of elements with a ratio of sides less than 3 was - 31.7, with a ratio of sides more than 10 was 11.2.

The model of the open wagon body strength at angular displacements relative to the longitudinal axis (case of the greatest loading of the bearing structure) takes into account the following loads: vertical static load P_v^{st} wind load P_v , discharge of bulk cargo F_b (coal) P_f (Figure 5). As a result of the spatial arrangement of the chain tie, the force P_f , which will be transmitted to the bearing structure of the body of the open wagon by means of it, was decomposed into components. The real areas of applying loads to the assemblies of fastening of chain ties were modeled by setting of special elements - mending plates, the configuration of which is identical to the geometry of the contact zone of the hook interaction. It enabled simulating the fastening of the body of the open wagon relative to the deck with a maximum approximation.

The fastening of the model was carried out in the zones of supporting of the body of the open wagon on the bogies, as well as the supporting surfaces of mechanical stop-jacks.

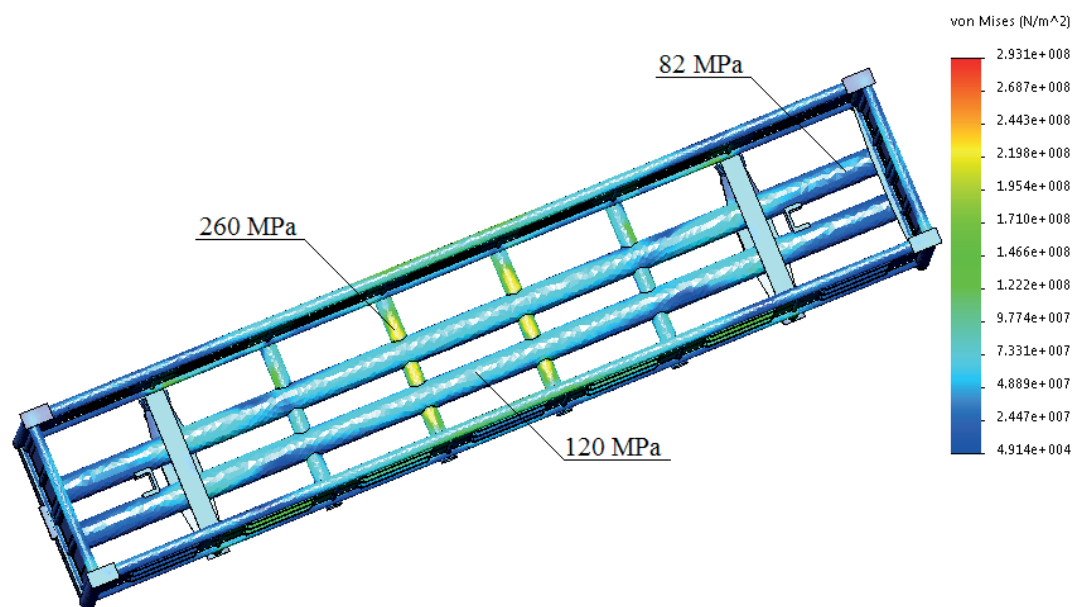

Figure 6 The stressed state of the bearing structure of the open wagon body at angular displacements relative to the longitudinal axis

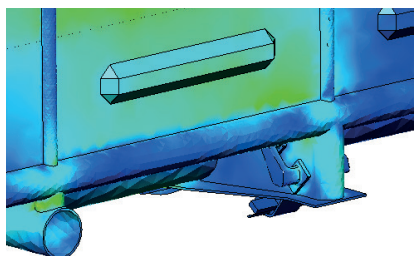

Figure 7 The stressed state of the bearing structure of the open wagon body in the zone of placement of the unit for fastening the chain binder

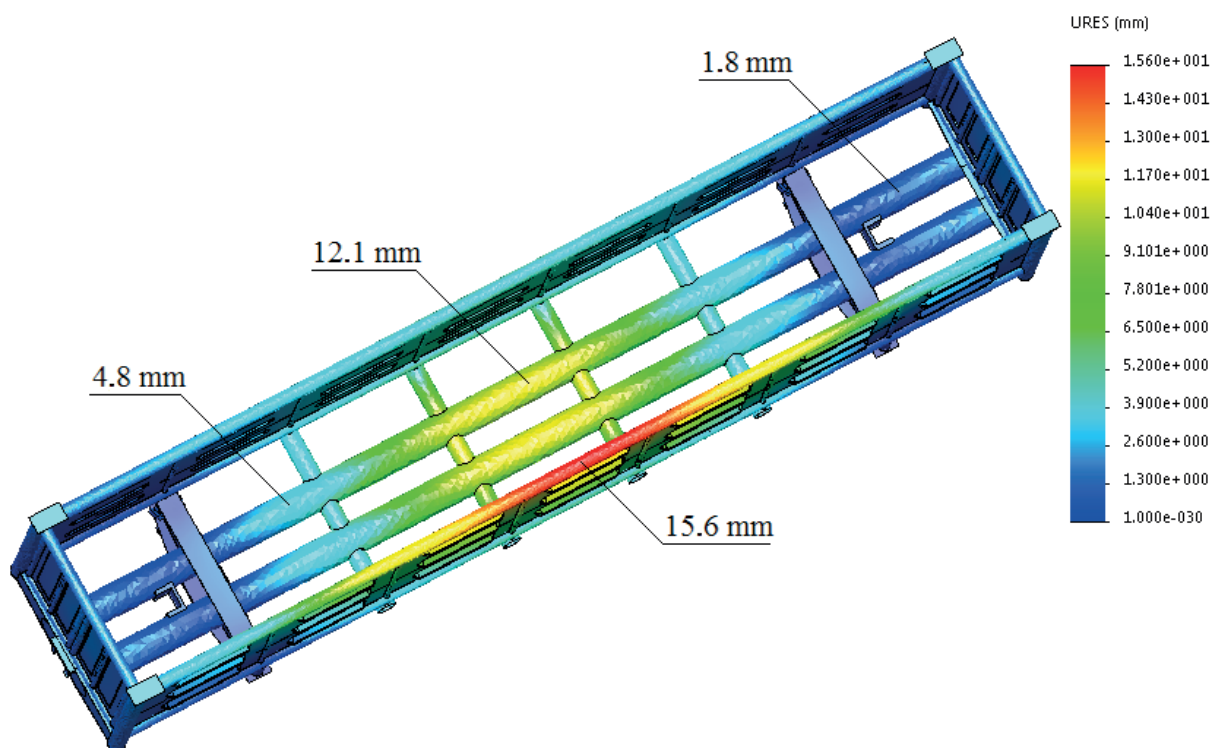

Figure 8 Moving in the nodes of the bearing structure of the open wagon

The results of the calculation are shown in Figures 6 - 8. From the conducted studies it can be concluded that the maximum equivalent stresses arise in the middle part of the frame and make up about 260 MPa, that is, they do not exceed the permissible values [21]. Maximum displacements arise in the middle part of the side wall of the body of the open wagon from its slope at the roll and amount to 15.6 mm.

It is important to note that the maximum equivalent stresses of the body of the open wagon, bearing elements of which are made of round pipes, are almost 7% lower than in the typical construction [10].

The results of the strength analysis of other schemes of displacements of the open wagon body are given in Table 1.

4. Conclusions

1. To reduce the cost of design and manufacturing of the new generation of the open wagon bodies, it is proposed to design their carrying systems from round pipes. In order to exploit the proposed designs of wagons in international rail-water

communication, it is assumed that stacking of assemblies for fastening of chain binders is provided for them;

2. Maximum values of acceleration as the components of dynamic load, acting on open wagons, made of round pipes, during its transportation on a railway ferry are determined. It is established that when the displacement of the body in the vertical direction for a wagon located on the upper deck, the maximum acceleration value is 0.84g, when angular displacement relative to the transverse axis for the extreme from the anchor point of the wagon body - is 0.1g, when angular displacement around the longitudinal axis for the extreme from the bulwark of the body of the wagon - is 0.24g;
3. The results of the strength analysis of the carrying structure of the open wagon body during its transportation on the railway ferry made it possible to conclude that the maximum equivalent stresses arise at the angular movements of the railway ferry, relative to the longitudinal axis and make up about 260 MPa, that is, they do not exceed the permissible ones;
4. The conducted research will enable an increase of the open wagons operation efficiency through international transport corridors.

References

- [1] FABIAN, T. P., et al. Versatile, efficient and long wagon for intermodal transport in Europe. *Communications - Scientific Letters of the University of Zilina* [online]. 2013, **15**(2), p. 118-123. ISSN 1335-4205/eISSN 2585-7878. Available from: <http://komunikacie.uniza.sk/index.php/communications/article/view/628>
- [2] DIZO, J., HARUSINEC, J., BLATNICKY, M. Computation of modal properties of two types of freight wagon bogie frames using the finite element method. *Manufacturing Technology* [online]. 2018, **18**(2), p. 208-214. ISSN 1213-2489. Available from: <https://ar1.ujep.cz/ar1-ujep/en/csg/?repo=ujeprepo&key=62113834886>
- [3] STASTNIAK, P., MORAVCIK, M. Freight bogie prototype properties analysis by means of simulation computations. *Manufacturing Technology*. 2017, **17**(3), p. 381-388. ISSN 1213-2489.
- [4] HAUSER, V., et al. Car body and bogie connection modification for track curves passability improvement. In 22nd Slovak-Polish Scientific Conference on Machine Modelling and Simulations (MMS 2017) : proceedings. Vol. 157. MATEC Web of Conferences [online], 2018. eISSN 2261-236X. Available from: <https://doi.org/10.1051/mateconf/201815703009>
- [5] GELVER, S. A. Investigation of the stressed-deformed state of the body of a freight open wagon of aluminium alloys, taking into account the physical nonlinearity of the material (in Russian). *Ural Transport*. 2008, **4**(19), p. 20-23. ISSN 1815-9400.
- [6] AFANASYEV, A. E. Improving the technique for assessing the technical condition and the rationale for extending the service life of open wagons (in Russian). *Ural Transport*. 2008, **1**(16), p. 49-52. ISSN 1815-9400.
- [7] MSC Software. *MSC Software Corporation* [online] Available from: <http://www.mscsoftware.ru>
- [8] BEYN, D. G. *Optimization of bodies of freight wagons of open type with a bearing floor* (in Russian). Author's abstract of Ph.D. dissertation in Technical Sciences. Bryansk, Russia, 2011.
- [9] FOMIN, O. V. Increase of the freight wagons ideality degree and prognostication of their evolution stages (in Russian). *Scientific Bulletin of National Mining University* [online]. 2015, **4**(3), p. 68-76. ISSN 2071-2227/eISSN 2223-2362. Available from: <http://nv.nmu.org.ua/index.php/ru/component/jdownloads/finish/54-03/8333-2015-03-fomin/0>
- [10] LOVSKA, A. A. Peculiarities of computer modeling of strength of body bearing construction of gondola car during transportation by ferry-bridge. *Metallurgical and Mining Industry* [online]. 2015, **1**, p. 49-54. ISSN 2076-0507/eISSN 2078-8312. Available from: http://www.metaljournal.com.ua/assets/Journal/english-edition/MMI_2015_1/10%20Lovska.pdf
- [11] NADER, M., et al. A railway car as an innovative engineering solution for transportation of semitrailers and road kits for intermodal transport. *Logistyka*. 2014, **4**, p. 2272-2279. ISSN 1231-5478.
- [12] PRIYA DIVYA, G., SWARNAKUMAR, I. A. Modeling and analysis of twenty tonne heavy duty trolley. *International Journal of Innovative Technology and Research* [online]. 2014, **2**(6), p. 1568-1580. ISSN 2320-5547. Available from: <http://www.ijitr.com/index.php/ojs/article/view/421/pdf>
- [13] KRASON, W., NIEZGODA, T. FE numerical tests of railway wagon for intermodal transport according to PN-EU standards. *Bulletin of the Polish Academy of Sciences Technical Sciences* [online]. 2014, **62**(4), p. 843-851. ISSN 0239-7528. Available from: <https://doi.org/10.2478/bpasts-2014-0093>

- [14] MYAMLIN, S., et al. Determination of the dynamic characteristics of freight wagons with various bogie. *Transport* [online]. 2015, **30**(1), p. 88-92. ISSN 1648-4142/eISSN 1648-3480. Available from: <https://doi.org/10.3846/16484142.2015.1020565>
- [15] FOMIN, O., et al. Experimental confirmation of the theory of implementation of the coupled design of center girder of the hopper wagons for iron ore pellets. *Eastern-European Journal of Enterprise Technologies* [online]. 2017, **5**(1)(89), p. 1-19. ISSN 1729-3774/eISSN 1729-4061. Available from: <https://doi.org/10.15587/1729-4061.2017.109588>
- [16] OKOROKOV, A. M., et al. Research into a possibility to prolong the time of operation of universal semi-wagon bodies that have exhausted their standard resource. *Eastern-European journal of enterprise technologies* [online]. 2018, **3**(7)(93), p. 20-26. ISSN 1729-3774/eISSN 1729-4061. Available from: <https://doi.org/10.15587/1729-4061.2018.131309>
- [17] FOMIN, O. V., LOVSKA, A. O., PLAKHTII, O. A., NERUBATSKYI, V. P. The influence of implementation of circular pipes in load-bearing structures of bodies of freight cars on their physico-mechanical properties. *Scientific Bulletin of National Mining University* [online]. 2017, **6**, p. 89-96. ISSN 2071-2227/eISSN 2223-2362. Available from: http://nvngu.in.ua/jdownloads/pdf/2017/06/06_2017_Fomin.pdf
- [18] LOVSKA, A. O. *Improvement of bearing structures of open wagon bodies for increasing the reliability of their fastening on railroad ferries* (in Ukrainian). Aauthor's abstract of Ph.D. dissertation in Technical Sciences. Kyiv, Ukraine, 2013.
- [19] KIRYANOV, D. V. *Mathcad 13* (in Russian). BKhV - St. Petersburg, 2006, p. 608. ISBN 978-5941578498.
- [20] ALYAMOVSKY, A. A. *SolidWorks/COSMOSWorks 2006 - 2007. Engineering analysis by the finite element method* (in Russian). DMK, Series "Designing", Moscow, 2007, p. 784.
- [21] EN 12663-2. Railway applications - Structural requirements of railway vehicle bodies - Part 2: Freight wagons.