

Branislav Dobrucký – Pavol Špánik – Róbert Šul \*

## IMPROVEMENT OF POWER ELECTRONIC STRUCTURE CHARACTERISTICS USING SiC TECHNOLOGY – OVERVIEW

*This paper is dedicated to the recent unprecedented boom of SiC electronic technology. The contribution deals with a brief survey of those properties. In particular, the differences (both good and bad) between SiC electronics technology and well-known silicon VLSI technology are highlighted. Projected performance benefits of SiC electronics are given for several large-scale applications at the end of the contribution. The basic properties of SiC material were discussed already at the beginning of 1980's, also in our work place [1].*

### 1. Introduction

Silicon carbide (SiC) based semiconductor electronic devices and circuits are presently being developed for the use in high-temperature, high-power, and/or high-radiation conditions under which conventional semiconductors cannot adequately perform. Silicon carbide's ability to function under such extreme conditions is expected to enable significant improvements to a far-ranging variety of applications and systems. These range from greatly improved high-voltage switching for energy savings in public electric power distribution and electric motor drives to more powerful microwave electronics for radar and communications to sensors and controls for cleaner-burning more fuel-efficient jet aircraft and automobile engines. In the particular area of power devices, theoretical appraisals have indicated that SiC power MOSFET's and diode rectifiers would operate over higher voltage and temperature ranges, have superior switching characteristics, and yet have die sizes nearly 20 times smaller than correspondingly rated silicon-based devices. However, these tremendous theoretical advantages have yet to be realized in experimental SiC devices, primarily due to the fact that SiC's relatively immature crystal growth and device fabrication technologies are not yet sufficiently developed to the degree required for reliable incorporation into most electronic systems. The widely spread usage of power semiconductors manufactured of SiC is one of the most promising developments at this market today. Because of the outstanding performance of this new material high voltage blocking active switches are under investigation [1], [7], [11].

This paper briefly surveys the SiC semiconductor electronics technology. In particular, the differences (both good and bad) between SiC electronics technology and well-known silicon VLSI technology are highlighted. Projected performance benefits of SiC electronics are highlighted for several large-scale applications. Key crystal growth and device-fabrication issues that presently limit the performance and capability of high temperature and/or high power SiC electronics are identified.

### 2. SiC Material Fundamental Properties

SiC is a material with outstanding properties for power semiconductor application. Beside research activities including different power semiconductor switch types, unipolar JFET devices for blocking voltage of more than 1200V are applicable as samples promising switching loss reduction above all [11].

In comparison with a similar table in [1] one can see that, the new material 4H-SiC with energy bandgap 3.2 eV has been developed and is mostly used in applications (see below in chapters 4 and 5).

The wide bandgap energy and low intrinsic carrier concentration of SiC allow SiC to maintain semiconductor behavior at much higher temperatures than silicon, which in turn permits SiC semiconductor device functionality at much higher temperatures than silicon. As discussed in basic semiconductor textbooks [1], semiconductor electronic devices function in the temperature range where intrinsic carriers are negligible so that conductivity is controlled by intentionally introduced dopant impurities. Furthermore, the intrinsic carrier concentration  $n_i$  is a fundamental prefactor to well-known equations governing undesired junction reverse-bias leakage currents [7].

As temperature increases, intrinsic carriers increase exponentially so that undesired leakage currents grow unacceptably large, and eventually at still higher temperatures, the semiconductor device operation is overcome by uncontrolled conductivity as intrinsic carriers exceed intentional device dopings. Depending upon a specific device design, the intrinsic carrier concentration of silicon generally confines silicon device operation to junction temperatures less than 300 °C. SiC's much smaller intrinsic carrier concentration theoretically permits device operation at junction temperatures exceeding 800 °C, and 600 °C SiC device operation has been experimentally demonstrated on a variety of SiC devices.

\* B. Dobrucký, P. Špánik, R. Šul

Faculty of Electrical Engineering, Dept. of Mechatronics and Electronics, University of Zilina,  
E-mail: branislav.dobrucký@fel.utc.sk, pavol.spanik@fel.utc.sk, robert.sul@fel.utc.sk

Comparison of Selected Important Semiconductor of Major SiC Polytypes with Silicon and GaAs [7].

Tab. 1

Property	Silicon	GaAs	4H-SiC	6H-SiC	3C-SiC
Bandgap [eV]	1.1	1.42	3.2	3.0	2.3
Relative Dielectric Constant	11.9	13.1	9.7	9.7	9.7
Breakdown Field $ND = 10^{17} \text{ cm}^{-3}$ [MV/cm]	0.6	0.6	//c-axis: 3.0 //c-axis: 3.2	c-axis: > 1	>1.5
Thermal Conductivity [W/cmK]	1.5	0.5	3 - 5	3 - 5	3 - 5
Intrinsic Carrier Concentration [ $\text{cm}^{-3}$ ]	1010	$1.8 \times 10^6$	$\sim 10^{-7}$	$\sim 10^{-5}$	$\sim 10$
Electron Mobility @ $ND = 10^{16} \text{ cm}^{-3}$ [ $\text{cm}^2/\text{Vs}$ ]	1200	6500	//c-axis: 800   c-axis: 800	//c-axis: 60   c-axis: 400	750
Electron Mobility @ $NA = 10^{16} \text{ cm}^{-3}$ [ $\text{cm}^2/\text{Vs}$ ]	420	320	115	90	40
Saturated Electron Velocity [ $10^{17} \text{ cm/s}$ ]	1.0	1.2	2	2	2.5
Donor Dopants & Shallowest Ionization Energy [meV]	P: 45 As: 54	Si: 5.8	P: 45 As: 80	P: 85 As: 80	N: 50
Acceptor Dopants & Shallowest Ionization Energy [meV]	B: 45	Be, Mg, C: 28	Al: 200 B: 300	Al: 200 B: 300	Al: 270

The structure of 6H-SiC new material is shown in Fig. 1.

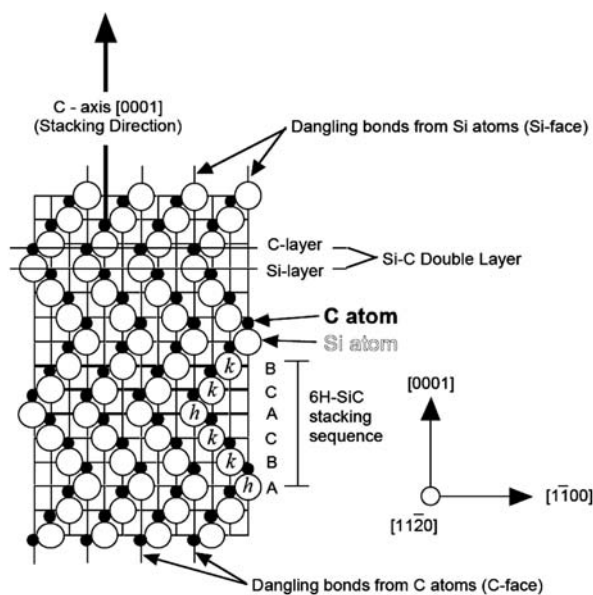

Fig. 1 Schematic cross-section  $\{(1120) \text{ plane}\}$  of the 6H-SiC polytype [7]

### 3. Comparison of conduction characteristics of Si and SiC

While SiC's smaller on-resistance and faster switching helps minimize energy loss and heat generation, SiC's higher thermal conductivity enables more efficient removal of waste heat energy from the active device (see Fig. 2). As heat energy radiation efficiency increases greatly with an increasing temperature difference between the device and the cooling ambient, SiC's ability to operate at high junction temperatures permits much more efficient cooling

to take place, so that heatsinks and other device-cooling hardware (i.e., fan cooling, liquid cooling, air conditioning, etc.) typically needed to keep high-power devices from overheating can be made much smaller or even eliminated.

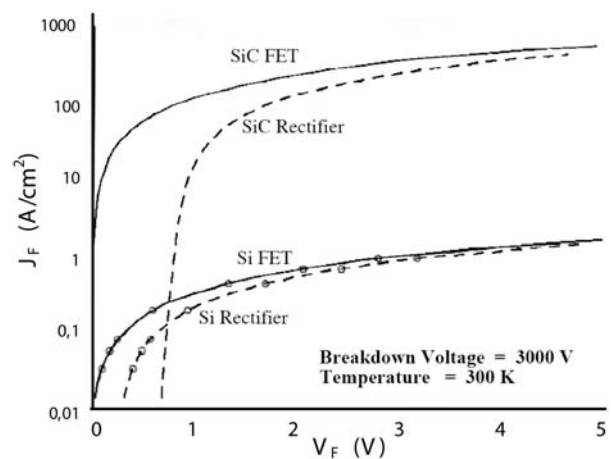

Fig. 2 Simulation experiment for forward conduction characteristics of ideal Si and SiC 3000 V

While so far discussions have been focused on high-power switching for power conversion [10], many of the same arguments can be applied to devices used to generate and amplify RF signals used in radar and communications applications. In particular, the high breakdown voltage and high thermal conductivity coupled with high carrier saturation velocity allow SiC microwave devices to handle much higher power densities than their silicon or GaAs RF counterparts, despite SiC's disadvantage in low-field carrier mobility.

#### 4. Advantages of SiC structure compared with Si material

As mentioned in Tab. 1, SiC is a wide-bandgap semiconductor, and this property of SiC is expected to yield greatly superior power electronics devices once processing and fabrication issues with this material are solved. Some of the advantages of SiC compared with Si based power devices are as follows:

- SiC-based power devices have higher breakdown voltages (5 to 30 times higher than those of Si) because of their higher electric breakdown field.
- SiC devices are thinner, and they have lower on-resistances. The substantially higher breakdown voltage for SiC allows higher concentrations of doping and consequently a lower series resistance. For lowbreakdown voltage devices ( $\sim 50$  V), SiC unipolar device on-resistances are around 100 times less; and at higher breakdown voltages ( $\sim 5000$  V), they are up to 300 times less. With lower  $R_{on}$ , SiC unipolar power devices have lower conduction losses and therefore higher overall efficiency.
- SiC has a higher thermal conductivity and thus a lower junction-to-case thermal resistance,  $R_{th-jc}$ . This means heat is more easily conducted away from the device junction, and thus the device temperature increase is slower.
- SiC can operate at high temperatures because of its wider bandgap. SiC device operation at up to  $600$  °C is mentioned in the literature. Most Si devices, on the other hand, can operate at a maximum junction temperature of only  $180$  °C.
- Forward and reverse characteristics of SiC power devices vary only slightly with temperature and time; therefore, SiC devices are more reliable.
- SiC-based devices have excellent reverse recovery characteristics. With less reverse recovery current, the switching losses and electromagnetic interference (EMI) are reduced and there is less or no need for snubbers.
- SiC is extremely radiation hard; i.e., radiation does not degrade the electronic properties of SiC. [8]

#### 5. Possibilities of application of SiC materials in power electronic systems

The structure of SiC Vertical Junction Field Effect Transistor is given in Fig. 3. Properties of this structure are as follows:

- Very high switchin speed
- High T capability (PN-isolation)
- Fast & robust PN body diode
- Volume mobility in the channel
- Doping: channel  $>$  drift region
- Suitable up to 3 - 4 kV
- Lowest  $R_{on}$  (today)
- No need for an external freewheeling diode

Cascode connection - basic connection V-JFET transistor (Fig. 4)

- $80$  m $\Omega$  ON-resistance ( $25$  °C) includes low voltage Si-MOSFET
- High short circuit capability

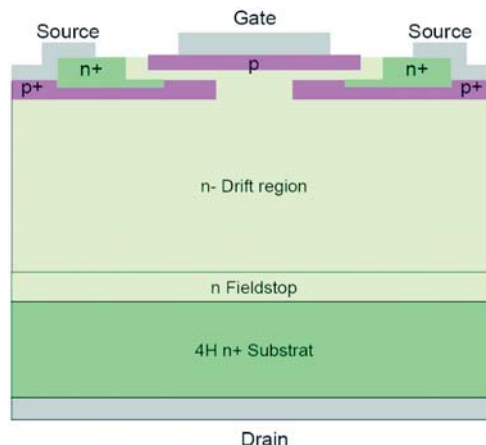

Fig. 3 Structure of SiC V-JFET

- Power almost totally on SiC V-JFET
- High T capability

Schematic diagram of the SiC Schottky diode structure, showing the field oxide, the overlapping metal electrode, and the epi-layer drift region (Fig. 5).

- Low-switch losses
- Breakdown voltages of 1000 to 1100 V
- High-Temperature Performance (over  $300$  °C)

Main applications:

- Power electronics

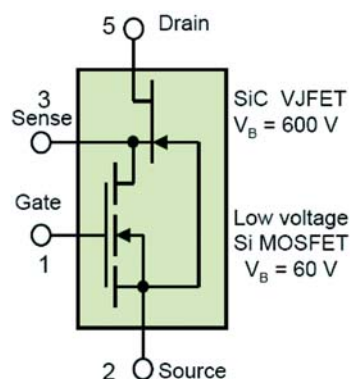

Fig. 4 Cascode SiC V-JFET + MOS FET

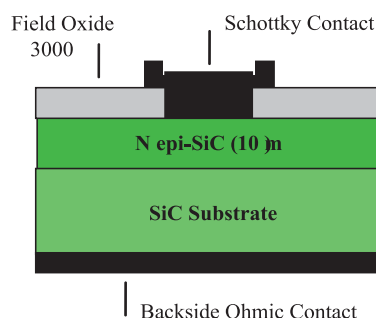

Fig. 5 Structure of SiC Schottky diode

- Power supplies
- Power converters
- PFC
- UPS
- Transmission and Distribution
- Power active filters
- FACTS
- Production of electric energy
- Photovoltaic systems
- Marine applications
- Wind-power plant
- Motor drives
- AC, DC drives
- SRM, SMPM drives
- Automotive
- Power amplifiers
- Defence,
- Aviation,
- Space program

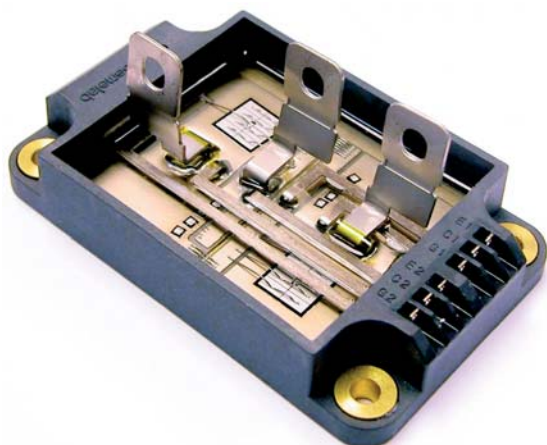

Fig. 6 SEMLab prototype 1200 V hybrid Si IGBT/SiC Schottky diode module [2]

Companies developing SiC devices:

- Diodes (Schottky/PIN) – Cree, Infineon/SiCED, Dynex, Eco-Tron, GF, Mitsubishi, Rohm, Semisouth, Int. Rectifier, Rockwell, STMicroelectronics ...

**References**

[1] DOBRUCKÝ, B., RÁČEK, V., ŠPÁNIK, P., GUBRIC, R.: *Power Semiconductors Structures* (in Slovak), EDIS Editor Zilina (SK),1995

[2] LOCATELLI, M. L., GAMAL, S. H., CHANTE, J. P.: *Semiconductor Material for High Temperature Power Devices*, EPE Journal (4) 1994, No. 1, pp. 43-46

[3] GRECKI, M., NAPIERALSKI, A.: *Static Induction Transistor – A New High Speed Power Device*. In: Proc. PEMC '94, Warsaw, Sept. 1994, Vol. 2, pp. 836-841

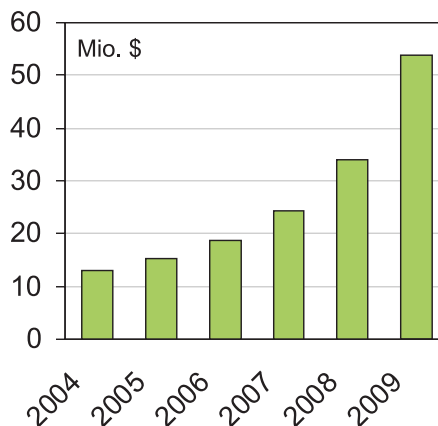

Fig. 7 2004 – 2009 World market for SiC devices

- Transistors (JFET/SIT) – Northrop, Cree, Infineon/SiCED, Semisouth, Rockwell, Hitachi, Intrinsic, Toshiba, Fairchild, Mitsubishi, Rohm, Philips, Nippondenso ...
- Thyristors – Cree, GE

**6. Conclusions**

The new possibilities and characteristics of the SiC structure are discussed and reported in the paper.

The new survey [17] forecasts that the world market for Schottky diodes and power transistors will grow from \$13 million in 2004 to over \$53 million in 2009. Schottky diodes, supplied by US Cree Company and by Infineon in Europe, will penetrate the microelectronics market at a much higher rate than transistors, which are less mature. Rockwell Scientific and Cree supply SiC MOSFETs, and another 15 companies, mostly major chip manufacturers, are working on further development of these transistors.

**Acknowledgment**

The authors wish to thank to the Ministry of Education of the Slovak Republic for the financial support of the project „Improvement of quality and exploitation of el. energy for traction and general applications“ No. 2003 SP 51/028 09 00/028 09 05-2003, and also to the Scientific Grant Agency for the project No. 1/0178/03.

- [4] JANUSZEWSKY, S.: *Power Semiconductors Devices- State of Art & Recent Trends*. In. Proc. PEMC '94, Warsaw, Sept. 1994, Vol. 2, pp. 861-866
- [5] HEUMANN, K.: *Trends in Semiconductor Devices and Impact on Power Electronics*. In Proc. PEMC'94, Warsaw, Sept. 1994, Vol.2, pp. 1288-1299
- [6] BENDA, V.: *Power Semiconductors and Integrated Structures*. ČVUT Editor, Prague (CZ), 1994
- [7] NEUDECK, P. G.: *SiC Technology*, NASA Lewis Research Center, Cleveland USA, 1998,
- [8] TOLBERT, L. M., OZPINECI, B., ISLAM, S. K., PENG, F. Z.: *Impact of SiC Power Electronic Devices for Hybrid Electric Vehicles*, SAE 2002 Transactions, Journal of Passenger Cars: Electronic and Electrical Systems, 2003, pp. 765-771
- [9] STEPHANI, D.: *The Industrial Utilization of SiC Power Devices - Aspects and Prospects*, Lecture given at the Workshop on Future Electron Devices (FED), Yokohama (JP), March 2003
- [10] STEPHANI, D.: *Today's and tomorrow's industrial utilization of silicon carbide semiconductor power devices*, Revue de l'Électricité et de l'Électronique, Feb 2004, pp. 23-24
- [11] DOMES, D., HOFMANN, W., LUTZ, J.: *A First Loss Evaluation using a vertical SiC-JFET and a Conventional Si-IGBT in the Bidirectional Matrix Converter Switch Topology*, of EPE'05 Conf., Dresden (DE), Sept. 2005, (CD-ROM)
- [12] [www.semlab.com](http://www.semlab.com)
- [13] [www.infineon.com](http://www.infineon.com)
- [14] <http://nina.ecse.rpi.edu/shur/SiC>
- [15] [www.iem.ing.tu-bs.de/paper/2004/kohi\\_04.htm](http://www.iem.ing.tu-bs.de/paper/2004/kohi_04.htm)
- [16] [www.siced.de](http://www.siced.de)
- [17] [www.wtc-consult.de](http://www.wtc-consult.de)