

COMPARISON OF SIMULATION AND EXPERIMENTAL AXIAL LOADINGS FOR HYDROMECHANICAL BULGE FORMING OF COPPER CROSS-JOINTS

Hydromechanical bulging is applied mainly to the series production of hydraulic installation and sanitary facilities including tubes with a changeable diameter, T-pipes and cross-joints. The process consists in placing a tube segment in a die-cavity, pouring some liquid over it and sealing the faces. As a result the liquid pressure rises and the pipe is upset. The basic parameters of the hydromechanical process of bulge forming are: liquid pressure and axial loading. The simulations of hydromechanical bulge forming were performed using MSC Marc software based on the finite element method. The calculation results were compared with the experimental data especially to study axial loading for different ratios d/D , s_0/D and for different variations of internal pressure. The results of numerical simulations of axial loading are in good agreement with the experimental data for established $\mu = 0,15$.

1. Introduction

The method of hydromechanical bulging of cross-joints was patented in 1973 [1]. Since then many research teams have been investigating the problem especially for steel T-pipes and cross-joints [2-8]. The technology involves placing a tube segment in a die-cavity, pouring some liquid over it, and sealing the faces. As can be seen from Fig. 1, the rising pressure of the liquid upsets the pipe.

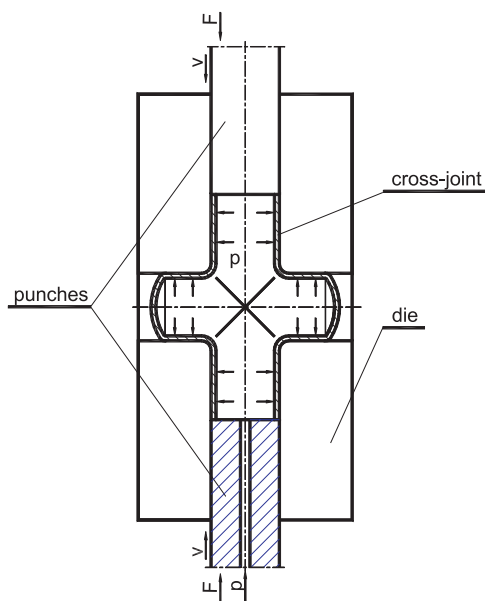

Fig. 1. Bulge forming of a cross-joint

As a result, we obtain bulged cross-joints with identical or different branch and outer diameters, the shape and dimensions being presented in Fig. 2.

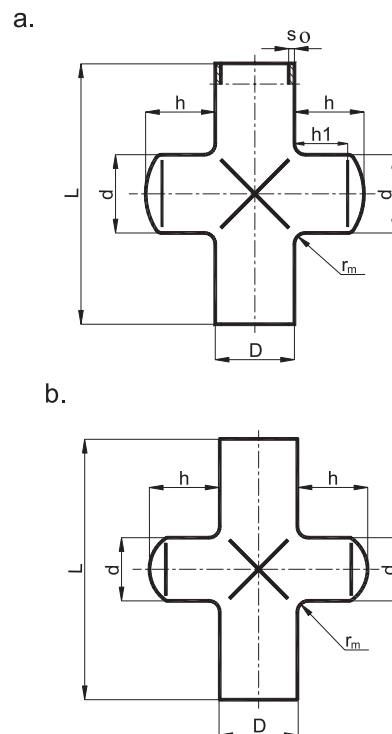

Fig. 2. Shapes and dimensions of cross-joints:
a) with $d/D=1$; b) with $d/D<1$.

* Jacek Chalupczak, Tomasz Milek

Division of Materials Technologies, Faculty of Mechatronics and Machinery Design, Kielce University of Technology, Al. 1000-lecia P.P. 7, 25-314 Kielce, Poland, Tel. +48 41 3424525, 3424373, e-mail jacek@tu.kielce.pl, tmatm@tu.kielce.pl

Except for the liquid pressure, the upsetting force is also responsible for hydromechanical bulge forming. As the stub pipe bulge on two sides, the lengths can be considerable. By applying appropriate pressure, it is possible to obtain a cross-joint with exactly the same dimensions - radius and diameter - as those of the die-cavity.

The paper discusses the significance of the upsetting forces in the hydromechanical bulge forming of copper cross-joints with the same and different branch and outer diameters. The forces values obtained by computer modelling were compared with the experimental data. The analysis takes into account various d/D and s_o/D ratios and pressure changes.

2. Methodology

MacNeal-Schwendler software was used for modelling. The basic calculation package was the general-purpose MSC. Marc program [4-7]. As the analysis concerned plastic working, it was required to apply MES program as well. The model was developed and analysed with the aid of MSC/MENTAT presented in [6]. A simulation of the hydromechanical bulge forming process was conducted for copper cross-joints with a relative wall thickness $s_o/D = 0.05$.

Table 1 presents the dimensions and mechanical properties of the samples of copper pipe sections used both in the modelling and testing of the bulged pipes. The properties were determined experimentally by static tensile testing (columns 4-7) and using the Heyer method of stepped specimens (columns 8-9).

The calculations and the experiment aimed at the following final geometry: length of the tubular blank section after bulging $l = 70$ mm, diameters of the stub pipes $d = 20$ mm and $d = 22$ mm if all diameters are identical ($d/D = 1$) and $d = 18$ mm and $d = 16$ mm if the diameters are different ($d/D = 0.9$ and $d/D = 0.8$ respectively).

The pipe was covered with a square mesh consisting of 7800 coating type elements, the thickness of which was established to be 1 mm. It was assumed that the matrix and dies/ were stiff rigid enough and could not be affected by any deformations [4-7]. The physical and mechanical properties of the deformed elements were compared with those of a model of a uniform material with good elasticity and plasticity. Thus, we had $\sigma_p = 524 \varphi^{0.33}$ for pipes with $s_o/D = 0.05$, and $\sigma_p = 517 \varphi^{0.27}$ for pipes with $s_o/D = 0.068$. In the simulation, the changes in pressure p , which were dependent

on the relative pipe bulging $\Delta l/l_o$, were assumed from the experimental data [3, 7, 8] obtained with a test facility described in [8]. The values of the coefficients of friction, $\mu = 0.1$ and 0.15 , were assumed to be the same as in [2].

3. Simulations and experimental results

The graph in Fig. 3 shows selected values of the upsetting forces obtained in the simulation and experiment. In this case, the cross-joints were hydromechanically bulged for a selected change in pressure (Fig. 3b) and the ratios $d/D = 1$; $s_o/D = 0.05$ assuming that the coefficient of friction μ was equal to 0.1 and 0.15 in the simulation.

As can be seen from Fig. 4, a decrease in the d/D ratio causes an increase in the pressure force of the stub pipes. While bulging at $\Delta l/l_o = 0.42$ the difference between the maximum values for $d/D = 0.8$ (55kN), and $d/D = 1$ (46kN) is 16.3%. The difference between the minimum values, on the other hand, $d/D = 0.9$ (48.6%), and $d/D = 1$ (46kN) amounts to approximately 5.3%.

In cross-joints with the relative wall thickness $s_o/D = 0.068$, the changes in the upsetting forces for various d/D are similar to those with $s_o/D = 0.05$; the values of the upsetting forces, however, turn out to be greater not only due to greater pressures but also due to thicker wall at the ends and in the centre of the cross-joints. The difference in the values of the forces for cross-joints with $s_o/D = 0.068$ ($d/D = 1 - 73$ kN and $d/D = 0.9 - 81$ kN) at $\Delta l/l_o = 0.42$ was 9.8%.

As the maximum values of the forces had to be assessed, the following tabulation was made (Table 2).

The greatest coincidence of the maximum values of upsetting forces obtained in the simulation and the experiment was reported for the assumed coefficient of friction μ equal to 0.15 . The difference ranged 4.54-16.85%. The simulation results were almost always smaller than the experimental data. The only exception concerned the modelling of a cross-joint with $s_o/D = 0.05$ and $d/D = 1$, where the maximum force was 4.54% greater than that in the experiment. This was the case when the smallest difference between the force values was established for $\Delta l/l_o = 0.42$.

4. Conclusions

1. The values of the forces responsible for the bulge forming process calculated by computer modelling were reported to

Dimensions and mechanical properties of copper tubes

Table 1

$D_0 \times s_0$ [mm]	l_0 [mm]	s_o/D_0	R_m [MPa]	A [%]	$A_{11.3}$ [%]	Z [%]	n	C [MPa]
1	2	3	4	5	6	7	8	9
$\varnothing 20 \times 1$	120	0.05	268	31.4	29.7	49.7	0.33	524
$\varnothing 22 \times 1.5$	120	0.068	283.2	44.25	33	53.9	0.27	516.8

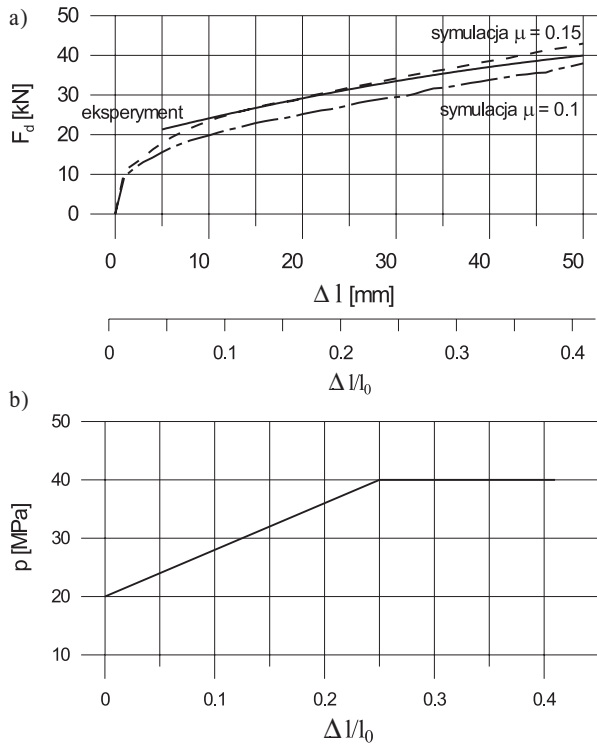

Fig 3. Comparison of the force waveforms (a) obtained by simulation and experimentally for copper cross joints at $s_o/D = 0.05$ and $d/D = 1$ hydro-mechanically bulged due to pressure changes, b) at the assumed coefficient of friction $\mu = 0.1$ and $\mu = 0.15$,

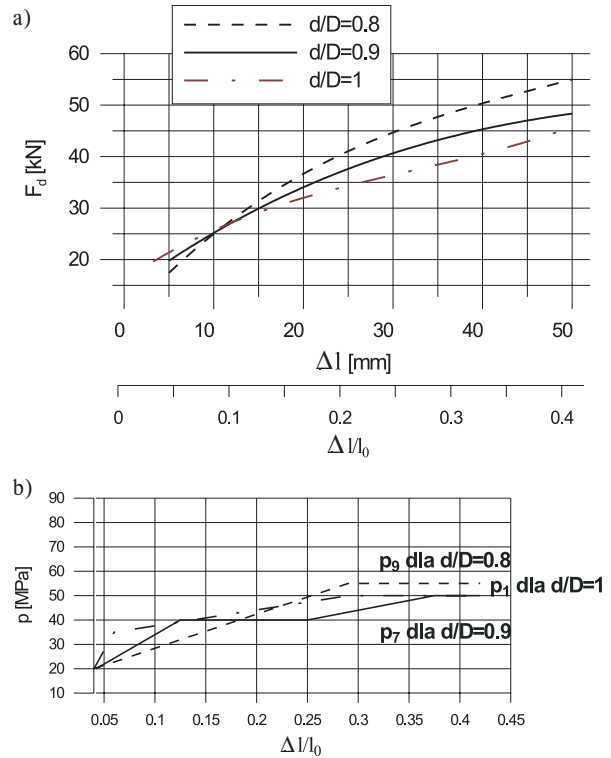

Fig. 4 Comparison of the force waveforms obtained experimentally for a) copper cross joints at $s_o/D = 0.05$ and $d/D = 1$, $d/D = 0.9$, $d/D = 0.8$ hydro-mechanically bulged by means of pressure changes, b) at the assumed coefficient of friction $\mu = 0.1$

A summary of maximum values of upsetting forces obtained by simulation and experiments performed for selected pressure changes

Table 2

Outer diameter of the tubular blank D [mm]	Tube wall thickness s_o [mm]	Relative wall thickness s_o/D	Pipe branch diameter d [mm]	Ratio of the pipe branch diameter to the outer diameter of body d/D	Established course of pressure p [MPa]	Maximum values of the axial loading for $\Delta l/l_0 = 0.42$	
						Simulation [kN]	Experiment [kN]
1	2	3	4	5	6	7	8
20	1	0.05	20	1	20-50	39.65 ($\mu = 0.1$)	46
					20-40	37.97 ($\mu = 0.1$) 42.95 ($\mu = 0.15$)	40
					20-50	42.19 ($\mu = 0.1$)	48.6
22	1.5	0.068	16	0.8	20-55	46.69 ($\mu = 0.1$)	55
			22	1	30-80	60.7 ($\mu = 0.15$)	73
			20	0.9	40-80	75 ($\mu = 0.15$)	81

be highly dependent on the assumed values of the friction coefficient. The greatest agreement of the simulation and experimental data was reported for $\mu = 0.15$.

2. The value of the upsetting force in the bulge forming of cross-joints increases:

- if there is a rise in the pressure used for the bulging; this is due to the fact that the greater the pressure, the greater the loads of the liquid on the swelling dies faces; moreover, this causes an increase in unit loads [2] in the contact area of the cross-joint and the die cavity,

- if there is a rise in the relative bulging ratio $\Delta l/l_o$, caused by an increase in the wall thickness in body area of the cross-joint [7] and in the material strength [4],
- if there is a decrease in the d/D ratio caused for example by greater plastifying stresses [4] in body area near the faces.

References

- [1] WASIUNYK, P. CHAŁUPCZAK, J.: *The method of manufacture of T-branch components and the tube bulging machine (in Polish)*, Patent Nr 98401
- [2] CHAŁUPCZAK, J.: *Hydromechanic bulging in the application to the forming of pipe tees and crosses (in Polish)*, Zeszyty Naukowe Politechniki Świętokrzyskiej. Mechanika, Nr 39, Rozprawa habilitacyjna, Kielce, 1986
- [3] CHAŁUPCZAK J., MIŁEK T.: *Selected problems of the research on hydromechanical bulge forming of copper cross-joints*, Materiały 5-th European Conference of young and science workers in transport and Telecommunications, Žilina, 2003
- [4] CHAŁUPCZAK J., MIŁEK T.: *The distributions of flow stress in hydromechanically bulged copper cross-joints and the research on axial loading in the process (in Polish)*, Rudy i Metale Nieżelazne, R49, 2004, Nr 10/11, pp. 529-534.
- [5] CHAŁUPCZAK J., MIŁEK T.: *The numerical analysis of reduced strains in hydromechanically bulged copper cross-joints (in Polish)*, Rudy i Metale Nieżelazne, R49, 2004, Nr 10/11, pp. 534-539.
- [6] KOCAŃDA A., CZYŻEWSKI P., MIŁEK T., SADŁOWSKA H.: *Computer simulation of cross-branch hydroforming (in Polish)*, Materiały X Jubileuszowej Konferencji „Informatyka w Technologii Metali”. KomPlasTech2003, Wisła-Jawornik, 2003, pp. 103-110.
- [7] MIŁEK T.: *Variations of wall thickness in the sections of hydromechanically bulged copper cross-joints (in Polish)*, Eksploatacja i Niezawodność, Nr 2/2003, pp. 45-48
- [8] MIŁEK T.: *Examination of selected parameters of bulge forming of copper cross-joints (in Polish)*, Rudy i Metale Nieżelazne, R47, 10/11, 2002, pp. 536-539.