

B. Sergelen - P. Tušla - J. Pavelka \*

# MATEMATICKÝ MODEL DVOCH PARALELNE SPOJENÝCH SYNCHRÓNNYCH MOTOROV

## MATHEMATICAL MODEL OF TWO PARALLEL SYNCHRONOUS MOTORS

*Príspevok popisuje matematický model pohonu, tvoreného dvoma paralelne spojenými synchronnými motormi. Okrem vzťahov je uvedená bloková schéma modelov v prostredí MATLAB a výsledky simulačných výpočtov pre prípad rozbehu motora priamym pripojením na sieť. Práca je prvou etapou vytvorenia matematického modelu motorov napájaných z jedného meniča kmútočtu prúdového typu.*

*The contribution describes the mathematical model of electrical drive composed of two parallel synchronous motors. Besides the equations there is mentioned block scheme in MATLAB and simulation results of the starting of two synchronous motors supplied from network.*

*The next stage of research work will be to create the mathematical model of synchronous motors supplied from one current type frequency converter.*

### 1. INTRODUCTION

Variable speed drive with HV synchronous motor uses the HV current type frequency converter with same devices (thyristors) connected in series.

Studies prove that the real economical output power of these converters is higher than 3 MW. One of the possibilities to reduce the price of the drives is to use two or more small motors supplied by one converter. The experimental measurements showed that small oscillations could be detected.

The electrical equipment used in this current study consists of two parallel synchronous machines and one 6 kV current type frequency converter that operates in Brno, Czech Republic.

More detail studies of the oscillation cause and the methods for removing these are the subject of PhD thesis.

The results of the first stage of the study are mathematical models for the simulation of synchronous motors supplied from main voltage source.

### 2. THE MATHEMATICAL MODEL OF SALIENT POLE SYNCHRONOUS MACHINE

Simulating Salient pole synchronous machine, it is acceptable to make simplified assumptions. These assumptions cause an algebraization of armature equations and reduce the differential equation set of the model.

We assumed that the rotor magnetic paths and all of its electric circuits are symmetrical about both the pole and interpole axes for a salient-pole machine

The first assumption is that the stator windings are sinusoidally distributed along the air gap as far as mutual effects with the rotor are concerned. This assumption of sinusoidal distribution of the stator windings may be justified from the standpoint that in practically all synchronous machines, the windings are distributed so as to minimise all harmonics as much as is feasible. The principal justification comes from the comparison of performance calculated on that basis with actual performance obtained by test.

The second assumption is that the stator slots cause no appreciable variation of any of the rotor inductances with rotor angle.

Let us now assume that the stator is not cylindrical, the minimum reluctance being along the direct axis and the maximum reluctance along the quadrature axis. The inductances of the rotating coils and the mutual inductance between these and the stationary coils will now be functions of rotor position. We could expect the mutual inductance between the field winding and the rotor windings to be a sinusoidal function of angle as synchronous machines are designed to generate sinusoidal voltages.

After applying the phase and commutator transformations to the rotor windings as for the cylindrical machine, the situation is greatly simplified as the equivalent commutator rotor coils are magnetically stationary and, thus, inductance values are not functions of rotor position.

The voltage equations using the two phase's system of coils orthogonal phase transformation:

$$\begin{aligned} U_{\alpha} &= R_{\alpha} * I_{\alpha} + d\Psi_{\alpha} / dt \\ U_{\beta} &= R_{\beta} * I_{\beta} + d\Psi_{\beta} / dt \end{aligned}$$

\* Mgr. Byambaa Sergelen, Prof. Ing. Jiří Pavelka, DrSc., Ing. Petr Tušla

Department of Electrical Drivers and Traction, Faculty of Electrotechnical Engineering, CVUT Praha, Technická 2, CZ-166 27 Praha 6, Czech Republic, Phone: +420-2-2435 2149, 2435 2152, 2435 2134 Fax: +420-2-3119 972, e-mail: byamba@feld.cvut.cz, pavelka@feld.cvut.cz, tusla@feld.cvut.cz



where

$$S = (1 - \omega)$$

Rotating angle

$$\gamma = \int \omega dt + \gamma(0) \quad (8)$$

Computations have been made when synchronous machine is supplied by main voltage source.

The chosen computation model has been presented in Fig.1.

### 3. THE SIMULATION RESULTS OF THE STARTING OF TWO SYNCHRONOUS MACHINES

AC machines are supplied with balanced three-phase voltages and running at a constant speed away from synchronism. This condition includes the normal steady operation of an induction motor and is also of considerable importance in analysing the behaviour of both induction motors and synchronous motors during starting.

The analysis is based on Park's equations and applies directly to a synchronous machine with a damper winding on each axis in addition to the field winding.

In order to apply the analysis to the starting operation, it is necessary to make certain assumptions. The starting of motors is initiated by switching on the supply when the motor is at rest.

The starting conditions are thus a good deal more complicated for the synchronous motor than for the induction motors. It is possible to divide the start into two periods:

1. The exciter voltage in the field circuit is zero during the running-up period. The field winding is usually closed through a resistance during this first period and short-circuited in the field winding. This period is finished after some time and the motor is operated with a small slip.
2. The synchronising operation either switches in the exciter or, if the exciter armature has been included in the period alternator field circuit, switches on the exciter field.

We started two parallel synchronous machines during the first period.

The starting of a synchronous motor must therefore be considered in two parts: the running-up period can be dealt with in the same way as the torque that would be exerted if the motor

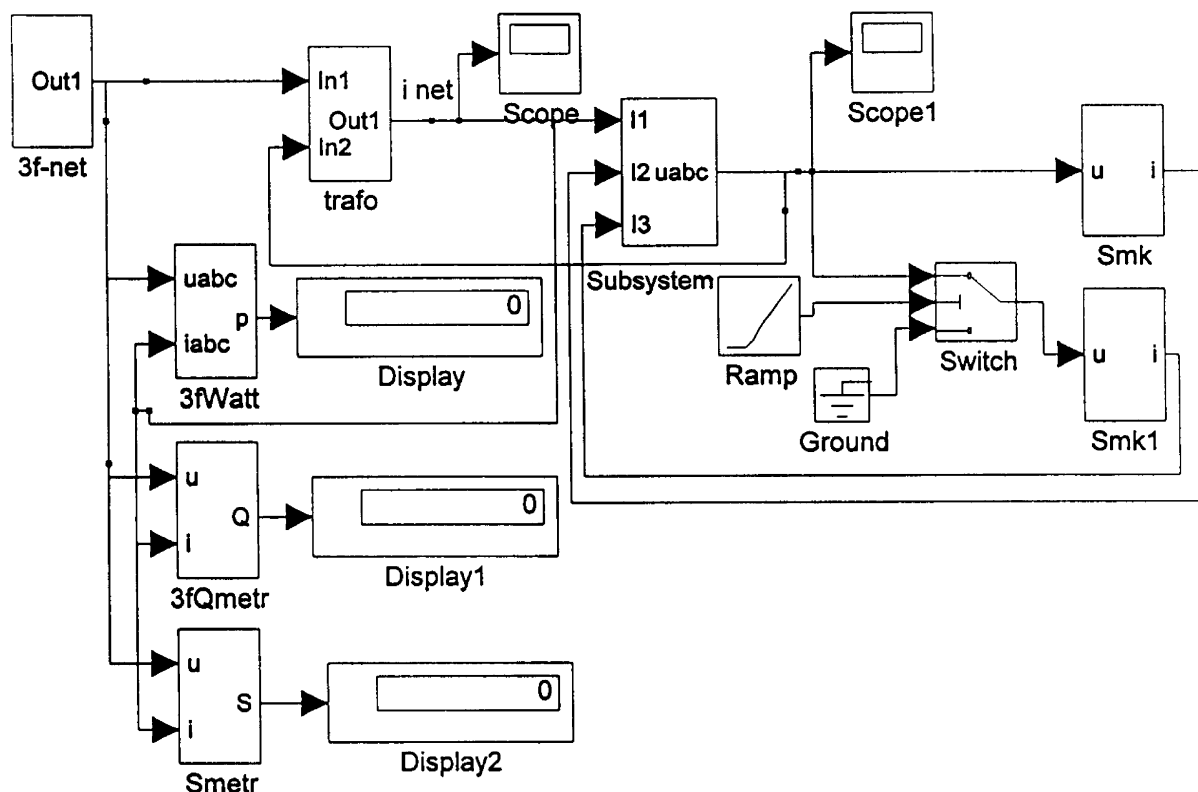

Fig. 2 Matlab model of two synchronous machines starting

ran at a constant speed. Secondly, the solution to the synchronising problem can only be found by solving the differential equations.

The calculation assumes that the applied voltage  $U_f$  in the field circuit is not zero. Consequently of it there are additional currents in the machine, which, by the principle of superposition could be determined separately by assuming the armature voltage to be zero. These currents produce a braking torque.

For this reason, synchronous motors are usually started up with the field unexcited.

The aim of the following mathematical development is, therefore, to find how the axis currents  $I_d$ ,  $I_q$  and flux linkages  $\Psi_d$ ,  $\Psi_q$  vary as functions of time during the starting.

Using the equation 4 it is possible to determine the instantaneous torque  $M_i$ . In the model for simulation of two parallel synchronous machines starting two subsystems "simulink" as well as 2 synchronous machines are used .

The Matlab model of two parallel synchronous machines starting and subsystem simulink of the model of starting are shown in Fig. 2, Fig. 3 and simulation results are presented in Fig. 3 and Fig. 4.

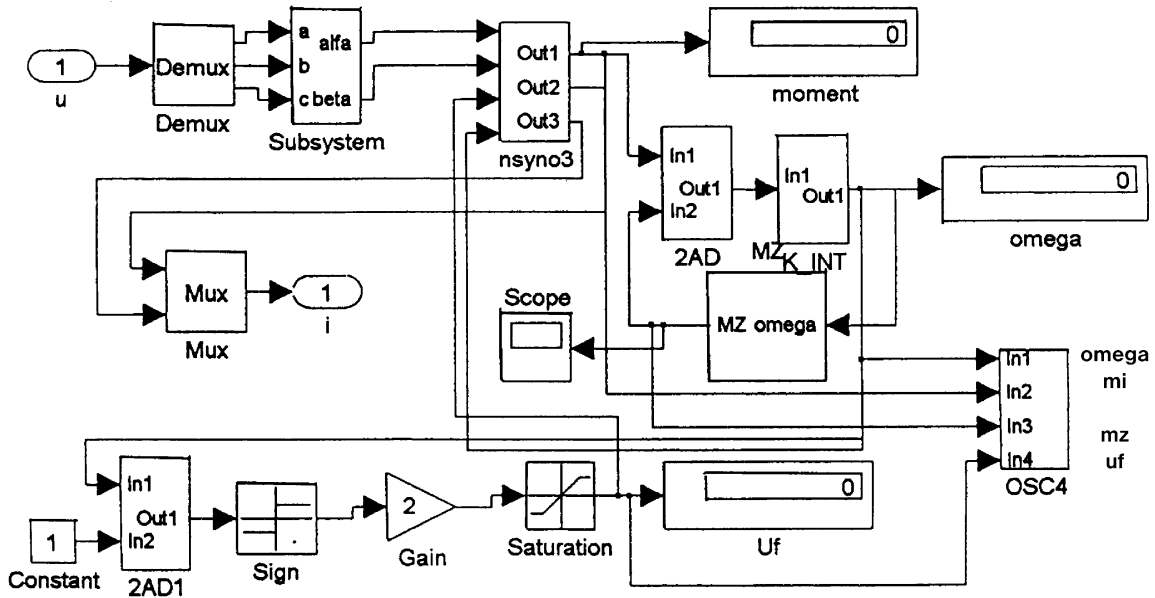

Fig. 3 Subsystem „Smk“ of starting model

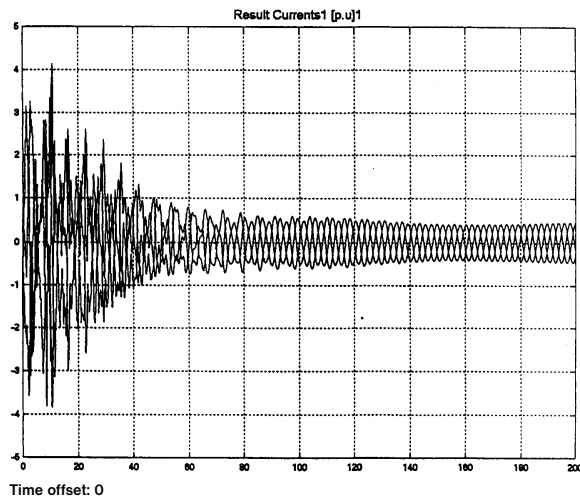

Fig. 4 Waves of result currents during the starting of two synchronous machines

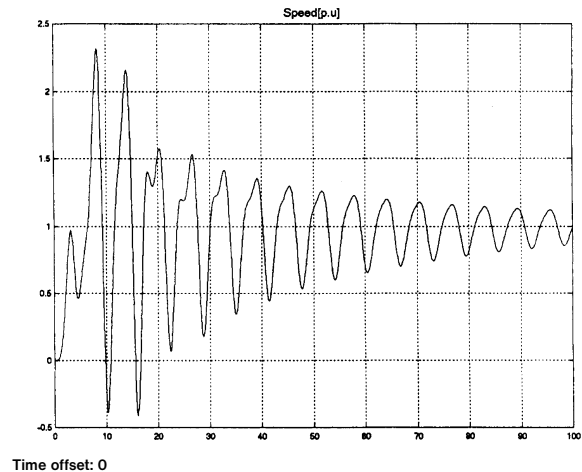

Fig. 5 Wave of the speed during the starting of two synchronous machines

#### 4. THE SIMULATION RESULTS OF SHORT-CIRCUIT

It is necessary to understand the nature of the short-circuit currents of synchronous machines, particularly for large machines, in order to apply proper relaying and switchgear and to evaluate the winding stresses and shaft torque's incident to short circuits. In a large power system, there may be considerable interaction and swinging among the various machines following a severe short circuit, and there may be voltage- regulator action. Short-circuit currents and torque of a salient pole synchronous machine are presented in Fig. 6.

#### 5. SMALL CHANGES OF PARALLEL SYNCHRONOUS MACHINES

An important issue to address is when synchronous machines are paralleled; they are subjected to small oscillations.

When synchronous machines are paralleled it is necessary to "synchronise" them before closing the paralleling breaker. This means that machines must be brought to the same speed, the same phase position and the same voltage.

When two or more machines are operated in parallel, they are as if coupled together by elastic coupling just as in the case of a synchronous motor electrically connected to a generator. They must run at exactly the same main frequency as long as they are coupled, but their instantaneous speeds change in some band.

The simulation method can be applied to a small change of any kind, but in most practical problems the superimposed change oscillates sinusoidal at a given frequency. A distinction can be made between forced oscillations and free oscillations.

Forced oscillations occur when there is an externally applied torque or voltage, such as the low-frequency pulsation set up in a diesel engine driving a generator which causes all the quantities in the system to pulsate at the same frequency. The problem is to

determine the values of any mechanical stresses or voltage fluctuations, which may cause difficulties in operation.

Free oscillations occur without any externally applied impulse. They arise by a process of self-excitation either in the machine itself or as a result of closed-loop feedback circuits around the machine, such as a voltage regulator or a speed governor. In a completely linear system, which fortunately cannot exist, the oscillation would rise to infinity.

In a large power system, where many generators and motors are connected, the problem of stability is of great importance.

It can be studied by deriving the linear equations for small changes or small oscillations and determining whether or not the change dies away in time, thus restoring the system to its original state. Because of the nonlinearity, the coefficients in the linearized equations are different for every operating point with the result that the system is stable at some points and unstable at others.

To calculate the behaviour of the system, it is necessary to imagine a small disturbance and to determine whether the oscillation is sustained after the disturbance is removed.

The theoretical treatment must first establish the values of all variables in a basic steady state, in which some of coefficients of the linearized equations appear.

In the next stage of studies we can use the developed mathematical model to detail analysis of free oscillations of two parallel synchronous motors supplied from current type frequency converter. We can also use the field current control as the stabiliser for free oscillations.

#### 6. CONCLUSION

We created a mathematical model of two Salient pole synchronous motors in parallel and we used our model for simulation of a short circuit and a starting of 2 parallel synchronous motors with one voltage source supply. The results of computations confirmed that the model is correct.

The study of Synchronous motors with current source supply and the cause of oscillation will be done in the next stage of the study.

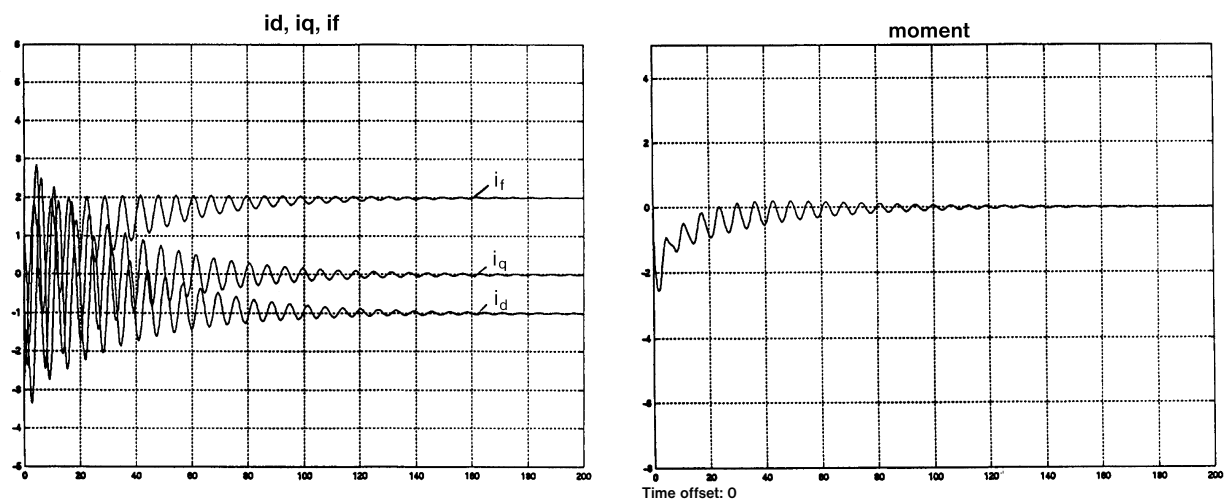

Fig. 6 Short-circuit operation

### Literatúra - References

- [1] ADKINS, B. and HARLEY, R. G.: "The General Theory of Alternating Current Machines". Chapman and Hall, London 1975
- [2] CONCORDIA, C.: "Synchronous machines". General Electric Company, London 1951.
- [3] MORGAN, A.T.: "General theory of electrical machines". London 1979.
- [4] BOBON, A., KUDLA, J. and ZYWIEC, A.: "Mathematical models of synchronous generators used in analysis of dynamic behaviour of electric power systems", IWEM97 Prague, p. 7-15.
- [5] KUDLA, J.: "Influence of saturation effect of the main magnetic field in the dynamic properties of synchronous generators", IWEM97 Prague, p. 25-36.

*Reviewed by: J. Timko, B. Dobrucky*