

Mirosław Wendeker *

ADAPTIVE FUELLING OF THE SI ENGINE

The paper presents some investigations concerning implementation of the adaptive control methods for the control of the fuel injection in an automotive gasoline engine. As quality index the difference between a current emission level and the level obtained during the stoichiometric combustion was chosen. Stoichiometric mixture provides maximal conversion ratio of the catalytic converter. The paper presents mathematical procedures of the direct adaptive control, based on the adaptive algorithms, which use competitive estimators. Theoretical analysis was supplied with the results of computer simulation of the single point gasoline injection engine model.

1. Introduction

Despite various demands on fuelling of the engine during operation, there is one global quality index of the control algorithm, which affects the whole vehicle. This quality index is represented by the amount of consumed fuel – optimal control algorithm provides the highest fuel energy to engine output conversion efficiency, what meets the driver's expectations. Some limitations have to be taken into account during optimisation of the control algorithm and their influence on the optimisation procedures cannot be neglected. These limitations have character of the inequalitive (acceptable level of toxic emissions) or equalitive (driving comfort and engine durability) restrictions.

Experiments confirmed that the highest increase in hydrocarbons and CO emissions occurs during the engine warm-up test phase. Lambda probe is unable to estimate mixture content and the cold catalytic converter is ineffective, therefore vehicle cannot meet any exhaust emission standards. Counteraction is usually based on the use of the heated lambda probe and heated catalyst or application of a so-called start-up catalyst. Optimisation of the algorithm-controlling amount of fuel injected during the test warm-up phase requires labour-consuming experiments.

After completing the warm-up phase (i.e. when the catalyst reaches its proper operation temperature) fuelling control procedures become more important. Only 1 % deviation from the stoichiometric mixture causes 50 % reduction of the catalyst efficiency with only about 1 % difference in the fuel consumption level. It means that in mathematical task of optimising the fuel consumption, a certain level of the exhaust emissions serves as a penalty function. When the oxygen sensor becomes active, deviations of the mixture composition $\lambda(t)$ from the stoichiometric value can be treated as a quality measure J_λ of the fuelling control algorithm, what can be described by the following equation:

$$J_\lambda = \int_{t \in \{T_\lambda\}} (\lambda(t) - 1)^2 \cdot dt = MIN \quad (1)$$

where: T indicates time intervals, in which the rule of stoichiometric mixture is obligatory (so without periods like engine start-up, engine breaking, full throttle opening). Minimising the quality index J is a basic problem during the synthesis process of the control algorithm designed for the spark-ignited engine.

Mixture stabilisation around stoichiometric composition is a common problem met in many scientific researches, patents and applications [1, 2, 5]. This problem (e.g. oxygen content in the exhaust gases) is solved by means of a feedback control, where oxygen sensor serves as a feedback signal source and the amount of fuel in the inlet pipe is a controlled quantity. Fig. 1 presents a simplified control scheme. The quality of control depends on the proper controller structure and its calibration. Automatic control mostly requires controllers with parameters adjustable in a wide range. Proper selection of the parameters (tuning of the mixture controller) should lead to:

- stabilisation of the mixture at the stoichiometric ratio,
- stable operation of the controller,
- suppression of noise which influences exhaust composition and can be transmitted to the controller,
- insensitiveness to changes of the dynamic properties of the engine.

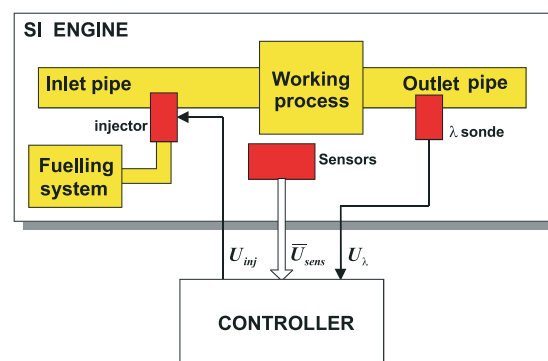

Fig. 1 A control scheme of the fuel injection in a SI engine

* dr hab. inż. Mirosław Wendeker, prof PL

Department of Internal Combustion Engines, Technical University of Lublin, ul. Nadbystrzycka 36, 20-618 Lublin, Poland
Tel.: +48-81-5381272, E-mail: wendeker@archimedes.pol.lublin.pl

Designing an efficient fuelling control algorithm is not a simple task. Such an algorithm should provide stoichiometric mixture, despite such factors as:

- fast changes of the engine operating conditions,
- signal noise, errors in the memorised map of the engine,
- engine cyclic variations,
- changes of the engine characteristics and exploitation interference.

Quality of the control is influenced by:

- type of the fuel injection system (SPI, MPI, GDI),
- method of the airflow measurement,
- structure and parameters of the engine model written into controller's memory
- type of the control algorithm.

Because of a great variety of available solutions, which can be implemented into electronic control systems of the SI engines, any comparison requires detailed experiments. Moreover, the most promising adaptive control systems are seldom described in literature [3, 4, 7].

An attempt to analyse adaptive control systems of the automotive engines requires computer-aided methods. In consequence, a mathematical model of the engine is necessary as a test object for the investigated control algorithms. Modelling of the engine needs to be compact and one of the main factors influencing this task is the availability of the data describing the object. Usage of the very complex model can be as well dangerous as too much simplification. Model of the engine should be easily identified, having enough complexity for the control purposes. Structural and parametric identification of the model requires experiments on the test bed, which are also the final verification of the simulated control algorithms.

This paper describes an implementation of the adaptive mixture control for the fuel injection controlling in a 1500 ccm four-cylinder SPI gasoline engine [6].

2. Adaptive mixture control

The fuel control system is the SISO (Single Input Single Output) system, where the input signal is dose of fuel and the output signal is the lambda signal. The mathematical description of the model is now

$$y(t) = - \sum_{i=1}^n g_i(t) \cdot y(t-i) + \sum_{i=1}^m h_i(t) \cdot u(t-i) + \eta(t) \quad (2)$$

where $y(t)$ means lambda signal as a function of time, $u(t)$ means quantity of the fuel and g_i and h_i are the coefficients of the model. We can write

$$y(t) = \vartheta^T(t) \cdot \varphi(t) + \eta(t) \quad (3)$$

where

$$\vartheta^T(t) = [g_1(t), \dots, g_n(t), h_1(t), \dots, h_m(t)]i \quad (4)$$

$$\varphi^T(t) = [-y(t-1), \dots, -y(t-n), u(t-1), \dots, u(t-m)] \quad (5)$$

and $\eta(t)$ is the output noise with $\rho = \sigma_n^2$.

The method of estimation can be expressed as:

$$\hat{\vartheta}(t) = \hat{\vartheta}(t-1) + P(t) \cdot \varphi(t) \cdot \epsilon(t) \quad (6)$$

$$\epsilon(t) = y(t) - \hat{\vartheta}^T(t-1) \cdot \varphi(t) \quad (7)$$

$$\hat{P}(t) = \frac{1}{\beta} \left[\hat{P}(t-1) - \frac{\hat{P}(t-1) \cdot \varphi(t) + \varphi^T(t) \cdot \hat{P}(t-1)}{\beta + \varphi^T(t) \cdot \hat{P}(t-1) \cdot \varphi(t)} \right] \quad (8)$$

where β is the learning factor.

The problem of discrete models of controlled analog plants and the issue of identification of nonstationary object is the choice: velocity of identification versus quality of identification. Here is proposed a new approach to identification: parallel operating of competitive adaptive filters. The efficiency of the parallel estimation technique in self-tuning control systems is much better than using only one estimator. In this proposition, a few results of estimations (with few learning factors β) are compared

$$\hat{\vartheta}_j(t) = \hat{\vartheta}_j(N_j, y, \varphi | t) \quad (9)$$

and the best one is used for prediction of the next input

$$\bar{\vartheta}(t) = \hat{\vartheta}(t) = \sum_{j=1}^J \mu_j(t) \cdot \hat{\vartheta}_j(t) \quad (10)$$

where μ_j is equal to 1 or 0.

In the next parts of the paper, some numerical experiments are shown for checking a new method of adaptive control.

3. Computerised research system

Computer simulation is often the only way leading to comparative analysis of the control rules of the nonlinear objects, with stochastic parameters and operating conditions. Such simulations reduce costs of the experiment and allow precise analysis, which is free from disturbances unavoidable during test stand experiments. Moreover, in case of the automotive engine, fast exhaust gas analysis requiring precise and very costly equipment can be avoided.

In order to investigate adaptive control algorithms used for controlling mixture composition, a computer system was designed. The core of this system was a mathematical model of the single point fuel injection engine. Having an engine model capable of detailed representation of internal processes [5], the model of the controller was designed. It described reactions of the control algorithm (time of injection, spark advance, bypass air valve position) triggered by the data coming from on-board sensors. The most

common structure of the control system was accepted, typical for SPI automotive engines. It configured also the object of research: 1500 ccm engine of the Polonez GLI vehicle. Several simplifications were made. Such factors like: voltage of the wiring system, spark energy, ignition angle, hydraulic effects in the fuel system (caused by the fuel pump and fuel pressure governor), damping of the exhaust flow caused by the catalytic converter, impulse conversion of the rotational speed sensor, position of the ignition switch and vehicle speed were taken into account as factors influencing the controller, but with no search for detailed relations. The influence was described as a part of general deviation of the measurement-control qualities from the preset values. Other elements were described in the model as logical values or numbers. After reduction the modelled control system simulates indications from several sensors (crankshaft position, rotational speed, coolant temperature, throttle position, intake air pressure, oxygen content in exhaust gases) and simulates operation of actuators. Figs. 2 and 3 describe accepted model of the measurement-control system.

The model assumes that control system reacts when the crankshaft reaches TDC of the current piston in a compression stroke - for the 4-cylinder engine it happens every 180 deg. At this moment control algorithm has data from the sensors gathered between consecutive TDCs as a voltage course. The algorithm (e.g. to calculate mean values) can process regarding to actual needs these signals, but the readouts can be simulated by the algorithm for a given period as well. According to the quality index and limitations, control qualities are calculated for the cylinder being in the compression stroke. Injection starts immediately after determin-

ing injection time, stepper motor of the bypass air valve begins the movement towards its new position and ignition advance is triggered with advance to next estimated TDC position.

The model assumes that sensors have their specific metrological properties: precision, linearity, dynamic. Simulated measurement noise was added to their indications so as to reflect the engine cyclic variability. Successive sensors were described using the first-degree inertia model:

$$\frac{dy_p(t)}{dt} = \frac{1}{T} \cdot y_p(t) + \frac{k_p}{T_p} \cdot y_M(t) \quad (11)$$

where y_M denotes value of the physical quantity in the engine model, y_p is an indication of the physical to electrical converter, k_p - converter gain, T_p - conversion time constant.

The sensor indication has an error with normal distribution and variance dyp . Using the method of determining the deviation of normal distribution the following equation describes indication y_C of the sensor:

$$y_C = y_p(t) + \sqrt{-2 \cdot \Delta y_p \cdot \log(RND)} \cdot \cos(2 \cdot \pi \cdot RND) \quad (12)$$

where RND denotes random function within the range (0, 1). It is assumed that the calculated value y_C cannot exceed limits for the signal level:

$$y_{C, min} \leq y_C(t) \leq y_{C, max} \quad (13)$$

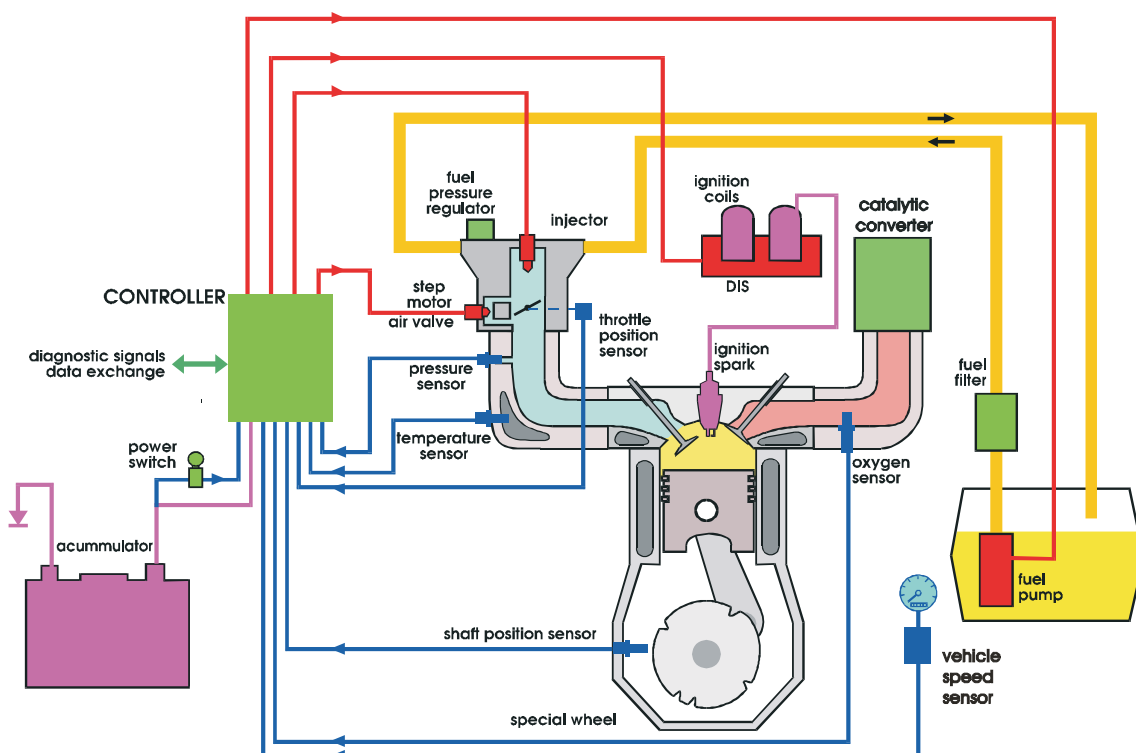

Fig. 2 General view on the control system accepted in the model

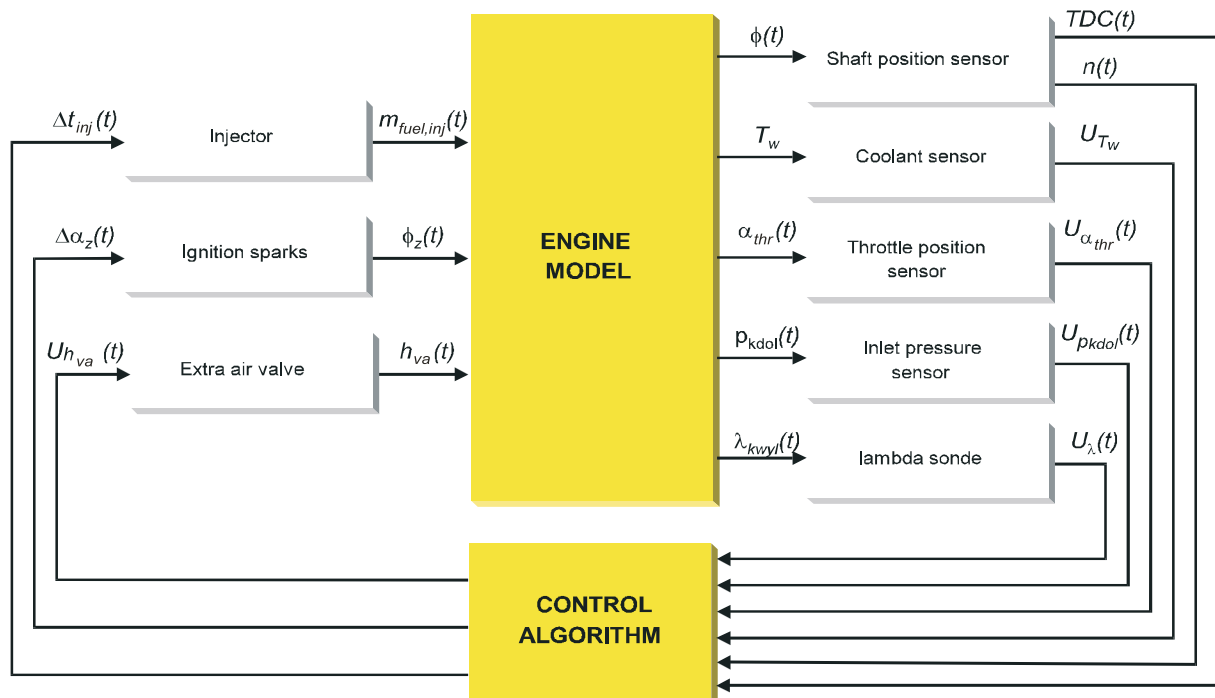

Fig. 3 Scheme of the control system accepted in the model

Corresponding quantities k_p , T_p , $y_{C,min}$, $y_{C,max}$ and d_{yp} for successive sensors are calculated on the basis of a manufacturer's data and experimental results. Rotational speed is calculated from the time difference between consecutive $(k-1, k)$ TDCs of the engine (with the assumed measurement error), according to the formula:

$$n(t) = \frac{30 \cdot N}{t_{TDC}(k) + t_{TDC}(k-1)} \quad (14)$$

It is also assumed that time of the injection Δt_{inj} calculated by the control algorithm is subject to various interferences influencing the fuel injection process, which leads to the difference between the assumed mass of injected fuel and the actual mass of injected fuel. Calculations are made on the basis of the following equation:

$$m_{fuel, inj}(t) = \hat{m}_{fuel, inj}(\Delta t_{inj}(t)) + \sqrt{-2 \cdot \Delta m_{inj} \cdot \log(RND)} \cdot \cos(2 \cdot \pi \cdot RND) \quad (15)$$

where stands for theoretical dependence between injected fuel and injection duration, Δm_{inj} is a variance of the injected mass of the fuel, both these quantities were identified on the engine test bed.

The computer system enabled modifications of the control algorithm. Having in mind necessity of stoichiometric mixture composition, it was possible to determine the influence of the algorithm controlling injection time on the exhaust gases composition for the consecutive engine cycles. The verified and identified mathematical model of the engine was used for the calculations. The engine model was able to simulate thermodynamic processes in the inlet pipes and in successive cylinders.

4. Simulations

Simulations were made according to the previously established plan of the experiment, which included three steps. The first step was to select the most valuable methods of estimation of the fuel and air mass reaching cylinders both at steady state and transient conditions. The second step was supposed to establish optimal structure and parameters of the controller according to the rules: PID, model adaptation and estimators cooperation. After the optimal structure was found, the third step of the experiment was initiated. 4 types of controllers were compared in conditions of significant deviations of the model parameters from their original values, written in the controller's memory. This comparison enabled to evaluate reactions of the controllers on the deviations, especially in the context of confirming the advantage of the controller based on the estimator battery cooperation.

Calculations of the engine work for the single investigation point were done both for the steady state and transient throttle positions. During the experiment the rotational speed and the coolant temperature of the engine remained constant as well as param-

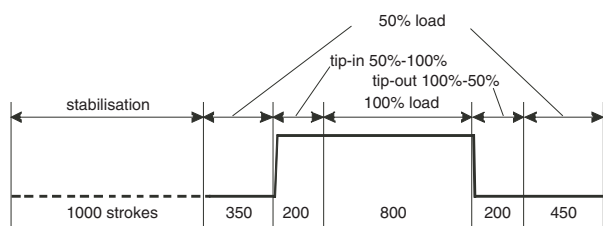

Fig. 4 Throttle position during one-point calculations

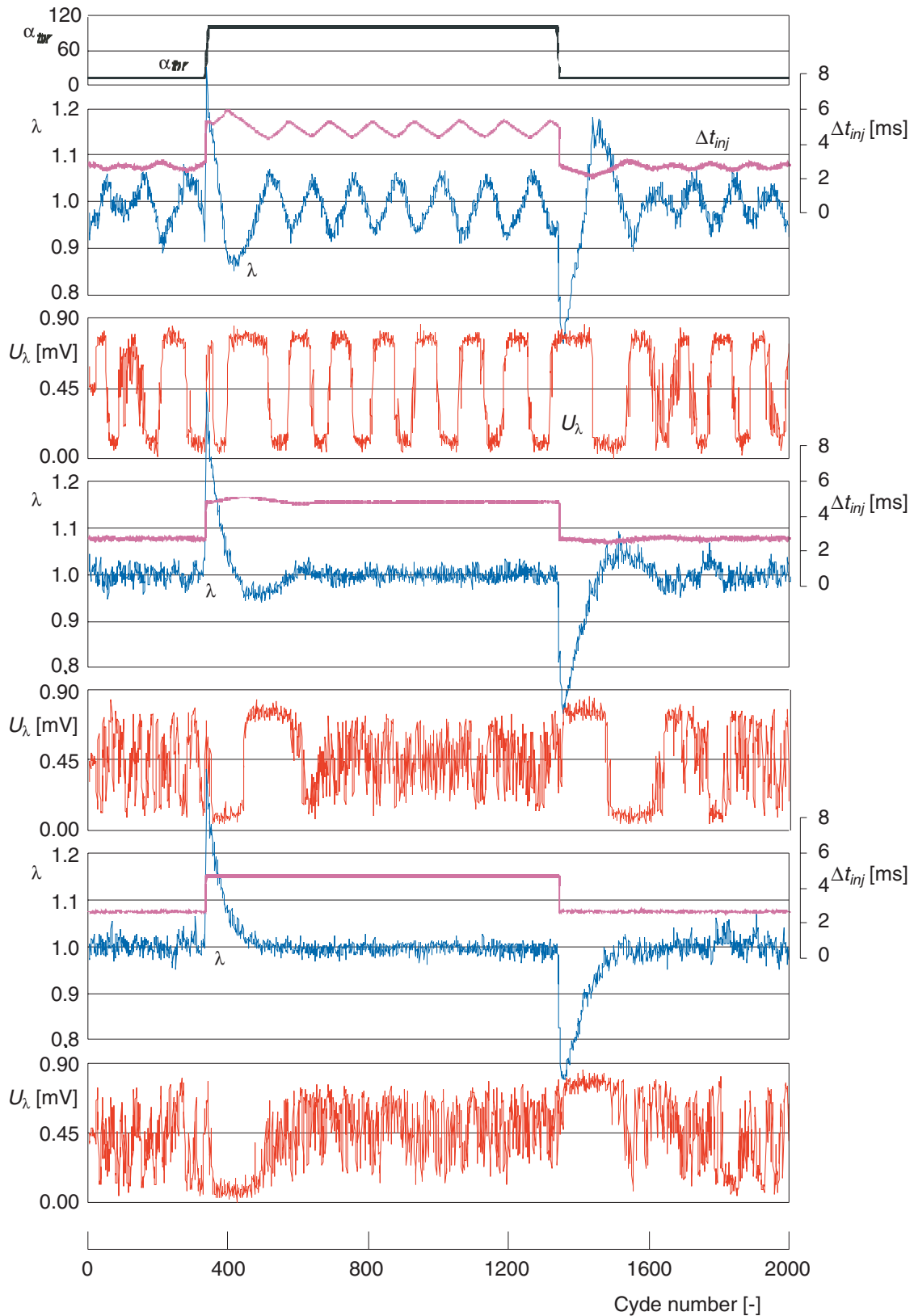

Fig. 5 Examples of the throttle movement, injection time, exhaust gases composition and lambda probe signal for the one point calculations for the three adaptive control algorithms characterised by different values of the learning ratio - from the top: 0,7, 0,8, 0,9.

ters of the surrounding air. Before the proper calculations, engine was running for 1000 consecutive cycles at the speed of 1500 rpm and throttle position giving mean inlet pressure level of 50 kPa (14 % throttle opening). The second steady state was set for the fully opened throttle and constant speed. Transient states were realised by the fast throttle repositioning (tips) between these two steady conditions. Fig. 5 shows throttle movement and steps of the calculations.

For the investigated control algorithm calculations were repeated five times. It was caused by the simulated signal noise, giving stochastic deviation values of the mixture composition, inlet pressure or on-board sensors readouts. The results of the calculations consisted of many quantities characterising physical processes in the engine and calculation process of the control algorithm. The most important were mixture composition signal and lambda signal (voltage) from the exhaust pipe. There were five indexes describing quality of the control:

- global control error - deviation of the mixture from the stoichiometric composition

$$\Delta\lambda_g = \frac{1}{T} \cdot \sum_{i=1}^{i=T} (\lambda_i - 1)^2 \quad (16)$$

- static control errors - deviations of the mixture from the stoichiometric composition in steady state conditions (for the 50 % and 100 % engine load)

$$\Delta\lambda_{S1} = \frac{1}{T_{S1}} \cdot \sum_{i=1}^{i=T_{S1}} (\lambda_i - 1)^2 \quad (17)$$

$$\Delta\lambda_{S2} = \frac{1}{T_{S2}} \cdot \sum_{i=1}^{i=T_{S2}} (\lambda_i - 1)^2 \quad (18)$$

- dynamic control errors - of the mixture from the stoichiometric composition in transient conditions (for the load changes)

$$\Delta\lambda_{D1} = \frac{1}{T_{D1}} \cdot \sum_{i=1}^{i=T_{D1}} (\lambda_i - 1)^2 \quad (19)$$

$$\Delta\lambda_{D2} = \frac{1}{T_{D2}} \cdot \sum_{i=1}^{i=T_{D2}} (\lambda_i - 1)^2 \quad (20)$$

Additionally an index for the lambda probe voltage was calculated, characterising deviation around 450-mV value

$$pU_\lambda = p(U_\lambda = 450 \pm \Delta U_\lambda) \quad (21)$$

Fig. 6 shows results of the calculations in the time domain. The following figures show influence of the inlet air and fuel mass assessment on the quality of the control both for the steady and non-steady conditions.

Fig. 7 depicts results of the calculations for the various parameters of the adaptive controller.

Fig. 8 shows comparison of the control quality with four types of control for deviations of the model parameters from their values preset in the algorithm. These parameters [percent values] are:

- k1 - difference in the fuel remaining on the inlet pipe walls,
- k2 difference in the time constant of the fuel evaporating from the walls
- k3 difference in the air reaching the cylinder.

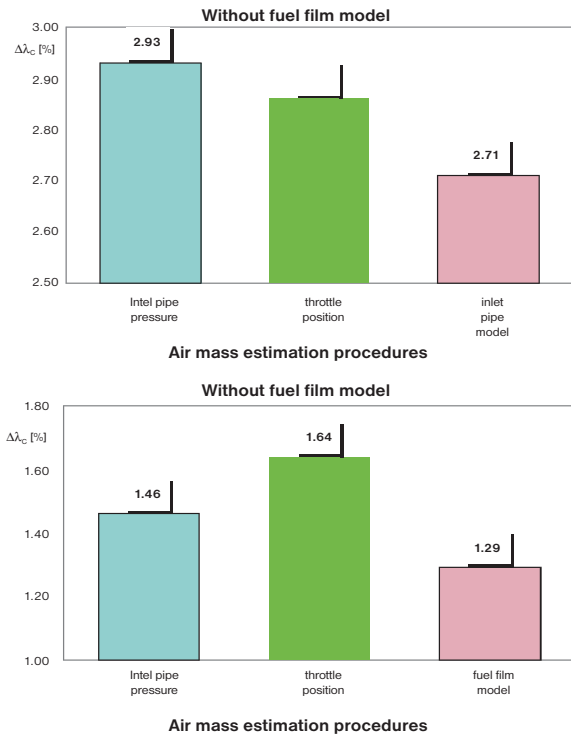

Fig. 6 Comparison of the total control error for the three methods of the cylinder air assessment and two methods including influence of the fuel film phenomena.

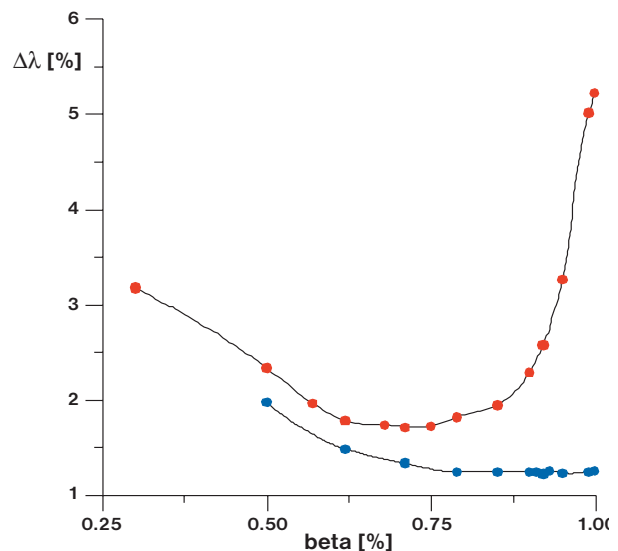

Fig. 7 Influence of the learning ratio on the total control error for the two different methods of including fuel film phenomena: no film (above), film present (below)

Types of controllers are:
 PID1 - optimal (for the whole test procedure) PID controller,
 PID2 - dynamic PID controller (useful at occurrence of rapid changes of model parameters)

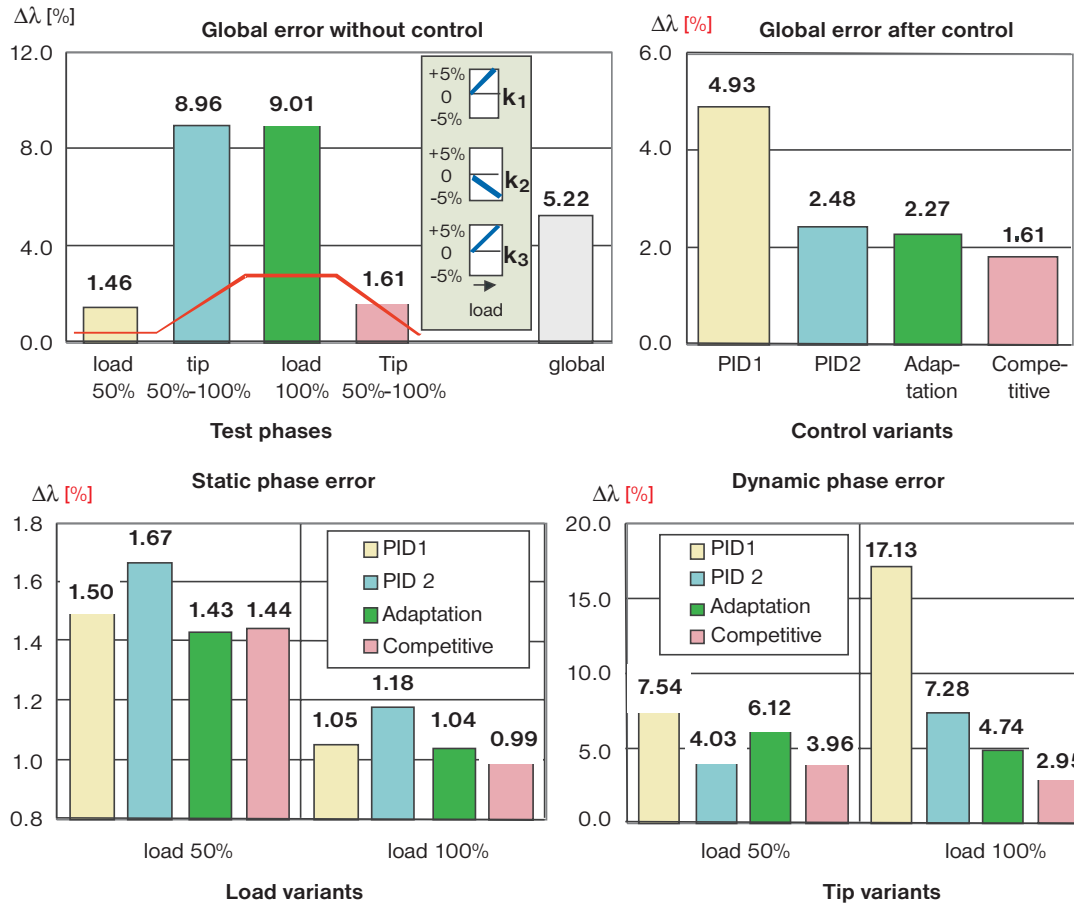

Fig. 8 Calculation results for the four types of the controller with presence of deviations in engine model parameters from their preset values.

Adaptation - optimal adaptive controller ($\beta = 0,90$)

Competitive - cooperating three adaptive estimators with different learning ratios.

5. Conclusions

The results of the simulations have confirmed that:

- the best method of the in-cylinder air assessment is based on the inlet pipe modelling, considering fuel deposition and evaporation from the walls significantly increases control efficiency,
- optimal adaptation speed can be established,
- controller based on the set of competitive estimators is more efficient than other investigated types, operation in conditions of erratic model results in smaller control error.

References

- [1] BENNINGER N., PLAPP G.: *Requirements and Performance of Engine Management Systems under Transient Conditions*. SAE Technical Paper No 910083, 1991.
- [2] HENDRICKS E. e. a.: *Transient A/F Ratio Errors in Conventional SI Engine Controllers*. SAE Technical Paper No 930856, 1993.
- [3] LENZ U., SCHROEDER D.: *Transient Air-To-Fuel Ratio Control Using Artificial Intelligence*. SAE Technical Paper No. 970618, 1997.
- [4] SHAFAI E., RODUNER CH., GEERING H.: *Indirect adaptive control of a three-way catalyst*. SAE Technical Paper No. 961038, 1996, pp. 185-193.
- [5] WENDEKER M.: *Experimental Results of the Investigation of the Mixture Preparation in Spark Ignition Engine*. SAE Technical Paper No 98456.
- [6] WENDEKER M.: *Adaptive Control of the Fuel Injection in the Spark Ignition Engine*. Technical University of Lublin 1998, 176 pp. (in Polish).
- [7] YAOZHANG B., YIQUN H.: *Decrease emissions by adaptive air-fuel ratio control*. SAE Technical Paper No 910391, 1991.