

Marek Kopiński – Andrzej Surowiecki *

LABORATÓRNE SKÚŠKY ZLOŽIEK SPEVNENEJ ZEMINY V ICH INTERAKČNEJ OBLASTI

LABORATORY TESTS OF THE INTERACTION ZONE BETWEEN REINFORCED SOIL COMPONENTS

V príspevku sa píše o výsledkoch laboratórneho skúmania zameraného na rozsah oblasti vzájomného pôsobenia v prostredí nesúdržných zemín a zvislo umiestnených výstuží. Skúmanie spočívalo v meraní bočného tlaku sústavy; vykonávalo sa na veľkorozmerných modeloch podložia (piesok, štrk, hrubozrnný pieskovec) s výstužou v tvare kovových alebo plastových sietí. Bolo dokázané, že rozsah oblasti výstuže v zvislom smere závisí od vlastností pôdneho prostredia a parametrov výstuže.

Laboratory investigation results related to the range of the interaction zone between a non-cohesive soil medium and vertically positioned reinforcement inserts are discussed. The investigations consisted of the measurement of the composite's side pressure; they have been carried out on large-scale models of subsoil (sand, gravel, grit) with reinforcements in the form of metal and plastic nets. It has been proved that the vertical range of the reinforcement effect zone depends upon characteristics of the soil medium and reinforcement parameters.

1. Introduction

For about 30 years, reinforced soil has been used in civil engineering throughout the world, for example, as the construction material for retaining walls erected under specific conditions. Modern solutions of reinforced-soil retaining structures vary, depending on types of wall elements and reinforcement inserts employed [1], [2]. As early as at the first stage of experiments with reinforced soil, back in sixties [8], interest awoke to the complex of causes and effects that result in the initiation and development of interaction of loose medium with reinforcement inserts. Successive investigations and theoretical analyses [4], [5], [6] led to the mathematical formulation of the so-called anisotropic cohesion, i.e. the local strengthening, which stabilizes a non-cohesive medium due to the effect of reinforcement.

Friction between the medium and reinforcement, due to its fundamental role in the reinforced soil operation, has been the subject of experimental and theoretical investigations for over 20 years [8]. The investigations are continued, and now they not only relate to how friction depends on the type of filling soil, but also to the mechanical aspect of the soil-reinforcement interaction [11].

Investigations on the recognition of factors affecting the reinforcement insert-granular soil interaction [9], [10], [11] have been undertaken at the Wrocław University of Technology. The occurrence of a medium strengthened locally in the vicinity of reinforcement inserts implies the existence of an area of reinforcement-medium interaction. The "interaction zone" is the area of rein-

forced medium subjected to external load, in which a decrease in deformability occurs with respect to the deformability of the reference medium, i.e. a medium with no reinforcement. If we assume that the interaction zone encompasses the whole range of the reinforced medium sample being discussed, the sample can be regarded as a homogeneous material from the standpoint of its operation (if no slipping occurs at the reinforcement-medium interface). The "interaction zone" is closely connected with the concept of the so-called "optimum separation" of parallel reinforcement layers. The optimum separation of reinforcement layers is defined as the vertical distance between reinforcement planes which ensures the highest effectiveness of reinforcement operation possible, i.e. the greatest attainable reduction in vertical and horizontal deformations of the reinforced medium sample.

No paper has been published over the last 30 years regarding the optimization of reinforcement layer separation and the separation's relation to the range (size) of the "interaction zone". A schematic representation of the concept of the so-called "optimum separation of reinforcement layers" can be found in the manual [3], but this by no means exhausts the issue, being only limited to a diagram and a short comment lacking not only any analytical formulae, but also a specification of factors that influence the value of "optimum separation". This, however, was not the aim of the manual mentioned.

There is a general consent between the authors of national leading publications on the subject that appeared in the last decade (e.g. [3], [7]) that in spite of wide-spread practical application of

* **Dr. hab. inż. Andrzej Surowiecki**, Institute of Civil Engineering, Wrocław University of Technology, Wyb. Wyspiańskiego 27, 50-370 Wrocław, Poland; T. Kosciuszko Military University, Dept. of Military Engineering, Czajkowskiego 101, 51-151 Wrocław; Agriculture University of Wrocław, Institute of Building and Landscape Architecture, Pl. Grundwaldzki 24, 50-363 Wrocław, Poland; E-mail: mr@biskupin.wroc.pl
Dr Ing. Marek Kopiński, Institute of Civil Engineering, Wrocław University of Technology, Wyb. Wyspiańskiego 27, 50-370 Wrocław, Poland

reinforced soil worldwide and extensive investigation performed, some mechanisms of reinforced-soil structure operation are still not completely understood. The paper [7] stresses the absence of rational methods of internal dimensioning applicable to reinforced soil structures, as well as the lack of generally recognized design standards – because of insufficient scientific exploration of reinforced soil.

The presented paper constitutes an experimental attempt at the recognition of interaction conditions of the reinforced soil components. There are discussed the results of model research conducted by the author in order to determine the effect of the factors selected (type and arrangement of reinforcement inserts, kind of loose soil medium, i.e. size of grains, degree of medium consolidation) on the vertical range of the spatial zone of reinforcement-loose soil medium interaction.

The size of “interaction” zone and optimum reinforcement layer separation has been determined based on the measurement of horizontal pressure exerted by load-subjected samples of soil. Also experimental strength parameters have been calculated for the reinforced medium samples.

2. Measurement procedure

The investigation was carried out using full-scale laboratory models. A diagram of the experimental stand is shown in Fig. 1. Reinforced medium samples (models) were placed in a rectangular steel container whose planar dimensions were 0.54×0.54 m and its height was 0.42 m. The design of the container’s walls and bottom allowed for the measurement of soil medium pressure. The values of side and vertical pressures of the medium on the subsoil being modeled were controlled by means of installed mechanical pressure gauges with elastic bands having a known elastic constant as their main sensing parts.

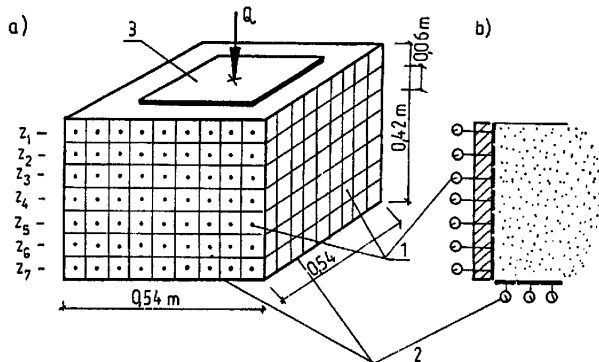

Fig. 1. Diagram and basic parameters of experimental setup: a – general view; b – vertical cross-section through soil container wall; 1 – mechanical sensor of horizontal pressure; 2 – mechanical sensor of vertical pressure; 3 – loading plate 0.31×0.31 m; $z_1 = 0.03$ m; $z_2 = 0.09$ m; $z_3 = 0.15$ m; $z_4 = 0.21$ m; $z_5 = 0.27$ m; $z_6 = 0.33$ m; $z_7 = 0.39$ m (measuring levels)

Belts with the elastic constant $C_s = 8 \text{ MN.m}^{-3}$ were installed for the sensors located in the container’s walls, while those with the elastic constant $C_p = 80 \text{ MN.m}^{-3}$ for the bottom sensors. Since the elastic bands are exchangeable, modifications of elastic susceptibility of the sensing parts in the container walls and bottom are possible.

The models were subjected to vertical and central load characterized by the unit pressure q within the range from 0 to 0.24 MPa. The reinforcement applied had the form of nets arranged horizontally, that is normally to the load plane, according to the principle of maximum work effectiveness for the inserts. Principally, steel nets with the 12-by-12-mm square mesh (symbol S 12) were used. Partial stiffness of the net’s knots resulted from the spatial layout of the nets – the interaction of this type of inserts with soil medium is determined by:

- friction between soil and reinforcement,
- shearing of soil medium (delamination) for the bars directed crosswise in the direction of horizontal forces (in this case, a resistance to the reinforcement’s transverse displacement due to the deformation of the load-subjected layer of the composite occurs, depending, among other things, on the degree of spatial shaping of the net).

For comparison purposes, other types of nets were also used, e.g. plastic nets. The models were reinforced with a single, double and triple nets. The following variable parameters were assumed:

- arrangement of the nets,
- consolidation of the soil medium.

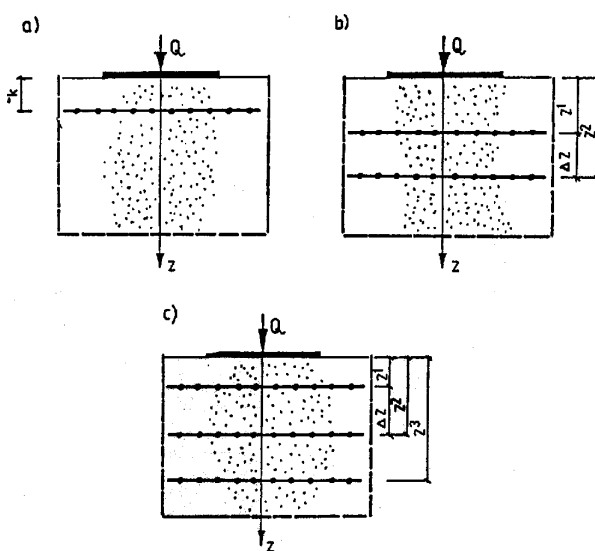

Fig. 2. Diagrams of investigation models: a – model with a single reinforcement insert (net); b – double-insert model; c – triple-insert model; z – insert levels

The reinforcement nets were located on the container’s seven measuring levels, spaced by the value of ($z = 0.06$ m; $z_1 = 0.03$ m; $z_2 = 0.09$ m; $z_3 = 0.15$ m; $z_4 = 0.21$ m; $z_5 = 0.27$ m; $z_6 = 0.33$ m; $z_7 = 0.39$ m. Coarse-grain dry sand was mainly used for the inves-

tigation, although for comparison purposes river gravel 5/10 and basalt grit 8/16 were also used. Two states of the soil medium were taken into account: (I) loosely spilled, and (II) preliminary compacted using the unit pressure $q = 0.24$ MPa (the medium was subjected to 8 cycles of load applying/removing). The load q was conveyed to the soil sample by means of a square steel plate with its side equal to 0.32 m. The value of the load induced ensures the stress uniformity at the model's height and therefore the vertical stress was assumed as $p_z = q_{max}$. Fig. 2 shows the diagrams of experimental models.

3. Investigation results for sand reinforced with a single insert

Figure 3 shows the plots of unit side pressure at the medium layer's depth for consecutive stages of applying load. The total zone of side pressure for the no-load medium is almost identical, both for the loosely dumped and reinforced one (see Fig. 3 a, curve 1). However, there appears - relatively small as yet - a difference in the shape of the side pressure curves. As the load increases, the pressure curve for the reinforced medium deviates in its shape from the reference curves. A characteristic influence zone of the reinforcement begins to develop on the reinforced medium's side pressure curves, especially apparent for the load $q > 0.10$ MPa (curves 2, 3, 4 in Fig. 3 a). This is defined as the reinforcement insert's influence zone on the soil.

The greatest reduction in the side pressure ordinate occurs in the reinforcement plane. The influence of reinforcement is transferred to the surrounding medium with a certain distance from it. The range of the reinforcement influence zone for a given soil type depends, among other things, on the following factors:

- the intensity of external load (the reinforcement constitutes a passive element) and the history of the load (e.g. a process of cyclic applying and removing load),
- technical properties of the reinforcement inserts (e.g. mesh size).

Horizontal forces of the soil side pressure are reduced by the reinforcement due to the friction of the medium's grains against the surface of the net rods, as well as due to the resistance to the movement revealed by the rods located crosswise with respect to the horizontal forces. The restriction of horizontal movement of soil grains directly at the surface of reinforcement inserts is propagated by means of inter-grain friction within a certain distance. This is defined as the effect of reinforcement-soil interaction. It can otherwise be termed as local "homogeneity" of a - normally discrete - granular medium which can be regarded as analogous to the so-called "anisotropic cohesiveness of reinforced sand", indicated in French investigations [4]. "Anisotropic" cohesiveness of the composite, which includes loose soil, occurs in the medium's grains found within the zone of the reinforcement "influence".

The cohesiveness is described by the formula:

$$c = 0.5 R_T \operatorname{tg} (0.25 \pi + 0.5 \varphi) (\Delta z)^{-1} \quad (1)$$

where: R_T - resistance of reinforcement layers to tension [$\text{kN}\cdot\text{m}^{-1}$],
 Δz - spacing of horizontal reinforcement layers [m],
 φ - internal friction angle of soil medium.

It is generally known that multiple load cycles applied to loose soil result in its being partially compacted. In the investigation, after eight cycles of applying and removing load, the increase in side pressure for the various stages of applying load in the eighth cycle was significantly lower. At the same time, the reinforcement influence effectiveness is smaller than a loosely spilled medium. This is evidenced by partial disappearance of the "interaction" zones (Fig. 3 b), very distinct in a loosely spilled medium (Fig. 3 a). Table 1 shows the reinforcement effectiveness index as a function of medium concentration for the case of a medium reinforced by a single insert S 12 at the level of $z_4 = 0.21$ m. As a measure of the effectiveness e [%], the ratio has been assumed of an average side pressure in a reinforced medium p_y^* [MPa] and that in a non-reinforced medium (i.e. reference) taken as $p_y = 100$ %:

$$e = p_y^*/p_y \cdot 100 \text{ [%]} \quad (2)$$

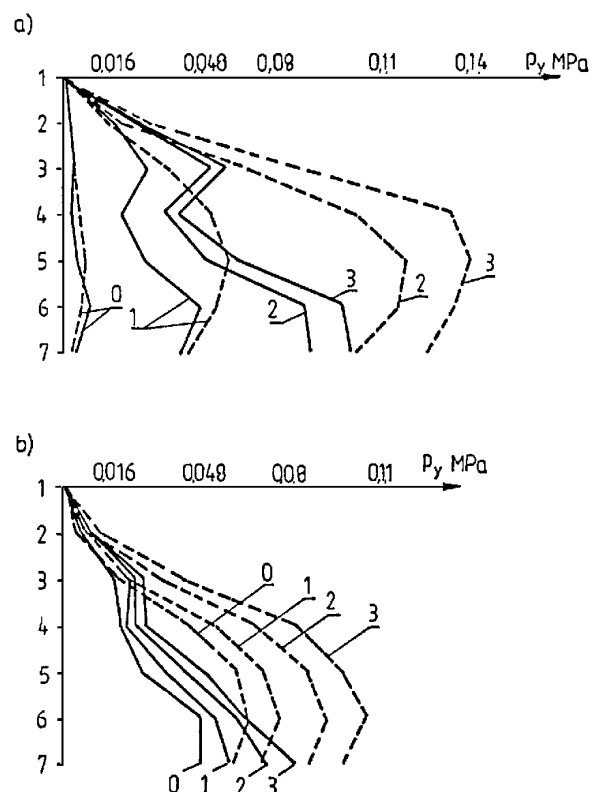

Fig. 3. Plots of unit side pressure at the level of sand layer at various loading stages: a - loosely spilled sand; b - preliminary compacted sand; - - - non-reinforced soil (reference); - - - reinforced soil with a single steel net with 12×12 mm mesh (designation S 12) at level z_4 ; 0 - without load; 1 - $q = 0.09$ MPa; 2 - 0.19 MPa; 3 - 0.24 MPa

Fig. 4 depicts plots of the unit side pressure for a loosely spilled medium reinforced with a single insert at the level $z_4 = 0.21$ m for

various types of reinforcement nets (related to the reference 1, i.e. no-reinforcement medium). The plots provide a comparison of effects obtainable by employing the reinforcement with a “rigid” 12-by-12-millimeter-mesh steel net (S 12), which is the common type of reinforcement, versus flexible nets and steel nets with various mesh sizes.

Table 1

Load q [MPa]		0.0	0.10	0.20	0.25
e [%]	loosely spilled sand	38.2	36.5	33.3	29.8
	preliminary compacted sand	47.2	43.3	40.8	39.3

Fig. 5 shows the side pressure distribution for a loosely spilled medium at the layer level. The figure illustrates the effect of reinforcement layout on the pressure value and pressure curve shape. The plots were taken for the pressure of $q = 0.24$ MPa. An analysis of the plots reveals that the reinforcement-generated reduction

of the horizontal soil pressure drops clearly below and above the optimum reinforcement position. For the case of extreme positions of the insert (Fig. 6a, c), the reinforcement influence zone is significant. In contrast, the central location of the reinforcement (Fig. 6b) results in the maximum range of the influence zone $v = v_{max}$ and in the consequent reduction of side pressure. Table 2 presents values of the total side pressure P_y^* expressed as percentages of the reference (P_y for the reference was assumed to be 100 %).

To sum up, the influence zone range v depends, among other things, on the type and state of soil and factors related to the reinforcement (e.g. geometric and material parameters of inserts, their arrangement). The granular medium-reinforcement interaction is satisfactory, if the insert does not produce soil delamination, is sufficiently rigid and develops sufficient resistance to being pulled out and has been located in the zone of maximum side pressure ordinates (of a non-reinforced medium). The optimum reinforcement effectiveness with respect to soil pressure reduction is to be expected in those places where maximum values of pressure ordinates p_y occur. Therefore, the most favorable case of reinforcement

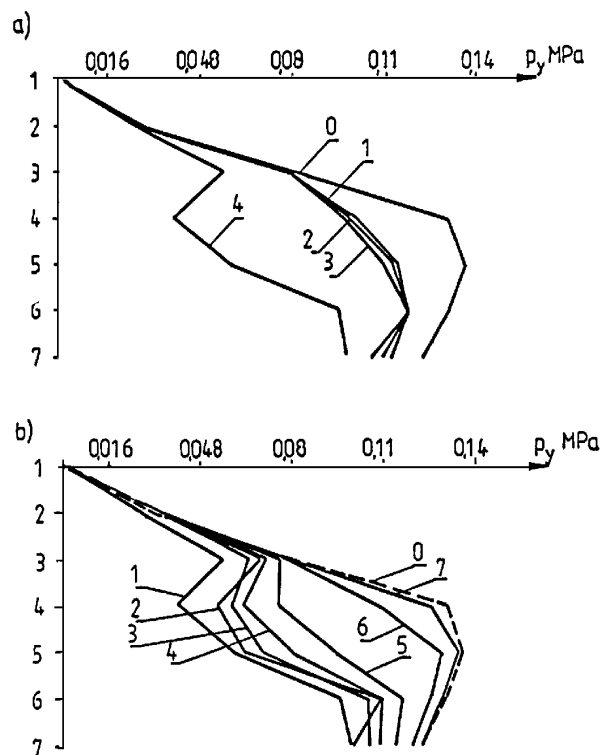

Fig. 4. Plots of side pressure for loosely spilled single-net-reinforced sand at level z_4 . Load $q = 0.24$ MPa.

- a) Designations: 0 - non-reinforced sand (reference); 1 - reinforcement of 45-by-45 millimeter plasti net; 2 - 14-by-14-millimeter plastic net; 3 - 6-by-6 millimeter plastic net; 4 - steel net S 12. b) Designations: 0 - reference; 1 - steel net S 12; 2 - 16-by-16-millimeter steel net; 3 - 27.5-by-27.5-millimeter steel net; 4 - 35.5-by-35.5-millimeter steel net; 5 - 74.5-by-74.5-millimeter steel net; 6 - 152.5-by-152.5-millimeter steel net; 7 - 220-by-220-millimeter steel net

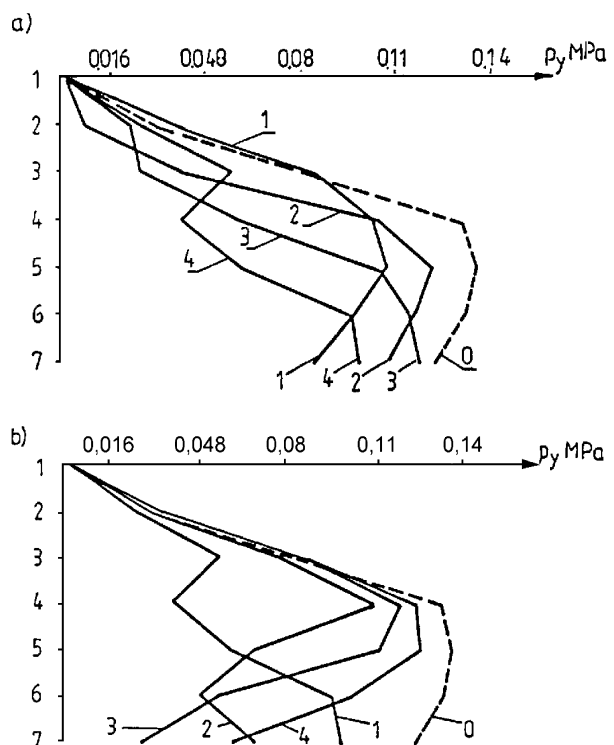

Fig. 5. Distribution of side pressure for loosely spilled sand at variable depth with respect to the location of single reinforcement by steel net S 12. Load $q = 0.24$ MPa. a) Designations: 0 - non-reinforcement sand (reference); 1 - reinforcement at level z_1 ; 2 - reinforcement at level z_2 ; 3 - reinforcement at level z_3 ; 4 - reinforcement at level z_4 . b) Designations: 0 - reference; 1 - reinforcement at level z_4 ; 2 - reinforcement at level z_5 ; 3 - reinforcement at level z_6 ; 4 - reinforcement at level z_7

localization is such where the reinforcement-soil "interaction" area covers as much as possible of the area bounded by the curve in the side pressure diagram for a non-reinforced medium.

Table 2

Positions of the nets z_k [m]	z_1	z_2	z_3	z_4	z_5	z_6	z_7	Non-reinforced
p_y^*/p_y loosely spilled sand	80.5	75.0	67.3	54.1	62.7	70.9	85.5	100
p_y^*/p_y preliminary compacted sand	82.3	78.0	70.1	57.0	65.3	73.0	75.4	100

4. Investigation results for sand reinforced with multiple inserts

Fig. 7 depicts diagrams of the side pressure taken at various measurement levels of a model, which employed the reinforcement of two S 12 nets. Fig. 8 shows the horizontal pressure of sand reinforced with three S 12 nets. Characteristic "interaction" zones of the reinforcement become noticeable in these cases, similarly to the single-net-reinforced sand. Even insignificant vertical dislocations of the inserts reflect visibly on the redistribution of side pressure

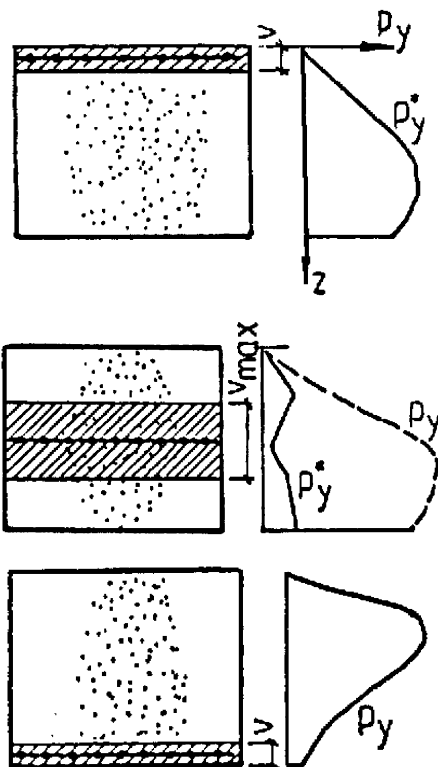

Fig. 6. Zone of local composite homogeneity (as determined by width v) due to reinforcement-soil interaction: a, b - extreme arrangements of insert; c - optimum position of reinforcement; — side pressure of reinforced medium; --- pressure of non-reinforced medium

ordinates. If both inserts are situated too close one to the other (in the double-reinforcement-layer arrangement), an effect arises analogous to the side pressure distribution for a medium reinforced with a single net; e.g. the total side pressure of double-reinforced sand at the heights z_5 and z_6 equals $P_y = 50.1$ % of the reference pressure (i.e. that for the no-reinforcement medium), while the pressure of single-reinforcement sand at the height z_5 equals $P_y = 62.3$ % for a similar distribution of pressure ordinates p_y (curves 1 and 2 in Fig. 9). For extremely unfavorable arrangements of two reinforcement planes, results can be even worse than for a single reinforcement, e.g. for double-reinforced sand with reinforcements at the levels z_6 and z_7 , the value of $P_y = 71.8$ % of the reference pressure has been obtained, while for a single reinforcement at the level z_6 , the total pressure P_y attains 70.9 % of the reference pressure (curves 3 and 4 in Fig. 9). The distribution of side pressure ordinates is similar and „interaction” zones are not visible. An optimum relative position of both reinforcement nets can be determined (vertical spacing $\Delta z = \Delta z_{limit}$), in which the maximum reduction in side pressure is attained and thus the effectiveness of reinforcement action is the greatest possible. For that case, the curve of unit side pressure between the levels of consecutive inserts does not reveal any convexity or concavity (case I in Fig. 10) and the inserts' interaction zones presumably overlap.

An increase in the vertical separation Δz_{limit} of inserts reflects unfavourably on the reduction in the soil side pressure; this is the case II in Fig. 10. The curve representing the soil pressure between the insert levels is convex which implies that the reinforcements do not interact in the medium through their respective influence zones.

A reduction in the vertical separation below Δz_{limit} results in overlapping of the influence zones; this produces an effect similar to the side pressure distribution for single-insert-reinforced soil or,

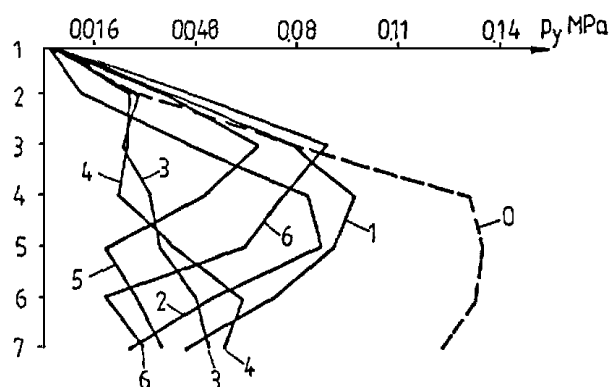

Fig. 7. Plots of side pressure at individual measuring levels of the model with loosely spilled sand reinforced with two S 12 nets, for various positions of the nets. Load $q = 0.24$ MPa. Designations: 0 - reference; 1 - reinforcement at levels z_1 and z_7 ; 2 - reinforcement at levels z_2 and z_6 ; 3 - reinforcement at levels z_3 and z_5 ; 4 - reinforcement at levels z_3 and z_4 ; 5 - reinforcement at levels z_4 and z_5 ; 6 - reinforcement at levels z_5 and z_6

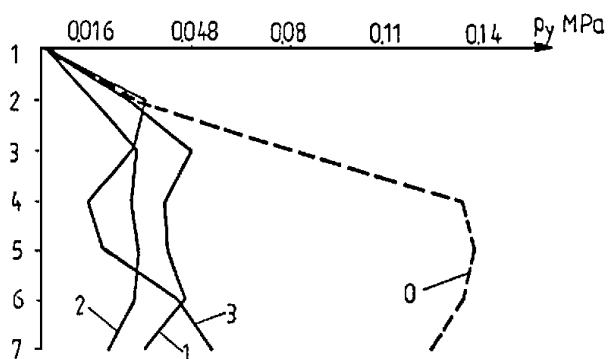

Fig. 8. Horizontal pressure of loosely spilled sand reinforced with three S 12 nets, for various positions of the nets. Designations: 0 - reference; 1 - reinforcement at levels z_1, z_4, z_7 ; 2 - reinforcement at levels z_2, z_4, z_6 ; 3 - reinforcement at levels z_3, z_4, z_5

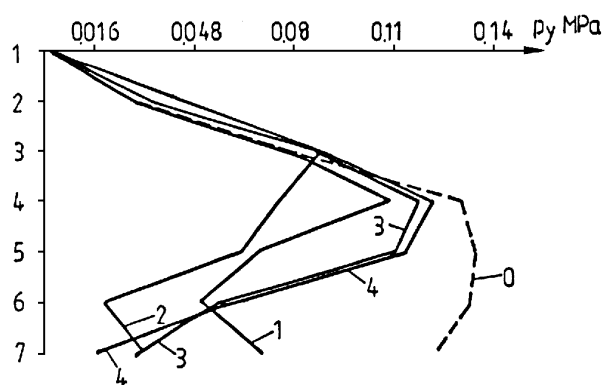

Fig. 9. Plots of side pressure for loosely spilled sand reinforced with S 12 nets. Load $q = 0.24$ MPa. Designations: 0 - non-reinforced sand; 1 - reinforcement with single net at level z_5 ; 2 - reinforcement with two nets at levels z_5 and z_6 ; 3 - reinforcement with single net at level z_6 ; 4 - reinforcement with two nets at levels z_6 and z_7

otherwise termed, the reinforcement action effectiveness decreases (case III in Fig. 10). For that case, the part of the soil side pressure curve contained between the levels of the inserts assumes a concave form and, as the model investigation shows, the reinforcement effectiveness drops. Tables 3 and 4 present values of the total side pressure of sand reinforced with two and three S 12 nets, respectively.

5. Strength characteristics of reinforced medium

Loose reinforced soil can be regarded as [6], [8]:

- a medium without cohesiveness, in which the internal friction angle is increased due to the application of reinforcement ($c = 0, \Delta\varphi > 0$);
- a soil, which if in extreme state, behaves as a cohesive anisotropic soil with the internal friction angle identical to that of non-reinforced soil but revealing properties indicative

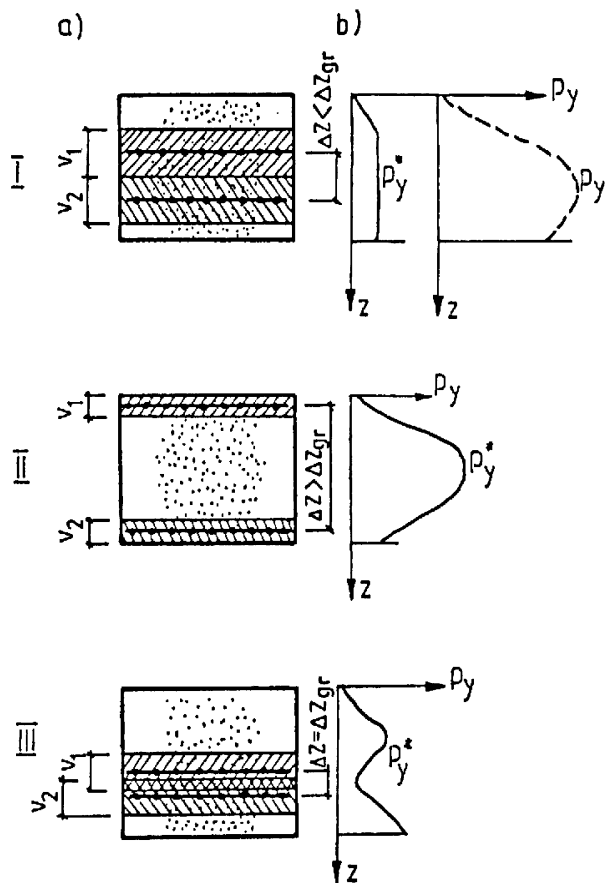

Fig. 10. Zones of local homogeneity for double-reinforced medium: a - cases I, II, III of localization of soil medium-insert interaction zones for two layers of reinforcement; b - plots of soil medium side pressure for cases I, II, III; v_1, v_2 - vertical range of soil-reinforcement interaction zone; --- plot of side pressure for non-reinforced medium; — side pressure for reinforced medium

of the cohesiveness directly proportional to the tensile strength ($c > 0, \Delta\varphi = 0$).

In the investigation, the active pressure p_y was measured which proved to be dependent on a number of factors. If, for the maximum load q_{max} , the values of p_z and the pressure coefficient K are regarded as their respective extreme values, then after inserting them into the classical extreme state equation, the effect of the angle φ increase in reinforced soil can quantitatively be evaluated. Such an approach has generally been acknowledged as admissible for the purpose of qualitative comparison involving mechanical characteristics of reinforced and not reinforced soil exposed to identical investigation conditions.

When considering the case of non-cohesive soil (a), the extreme state condition for non-reinforced soil samples can be expressed in its general form as:

$$p_y / p_z = \operatorname{tg}^2 (45^\circ - 0.5\varphi) = K_{min} \quad (3a)$$

and, by an analogy, for reinforced soil:

$$p_y^*/p_z = \operatorname{tg}^2(45^\circ - 0.5\varphi^*) = K_{min}^* \quad (3 \text{ b})$$

Table 3

Positions of the nets z_k^1, z_k^2, z_k^3 [m]	z_1	z_2	z_3	z_4	z_5	z_6	z_7	Non-reinforced	
	z_7	z_6	z_5	z_4	z_5	z_6	z_7		
p_y^*/p_y [%]	loosely spilled sand	68.2	48.2	33.6	35.0	35.3	50.1	71.8	100
	preliminary compacted sand	70.3	50.6	39.0	38.9	39.2	53.6	74.0	100

Table 4

Positions of the nets z_k^1, z_k^2, z_k^3 [m]	z_1	z_2	z_3	Non-reinforced	
	z_4, z_7	z_4, z_6	z_4, z_5		
p_y^*/p_y [%]	loosely spilled sand	36.4	23.6	28.2	100
	preliminary compacted sand	41.7	34.0	34.2	100

Also the relationships $\varphi^* > \varphi$ and $\Delta\varphi = \varphi^* - \varphi$ hold, where φ represents the internal friction angle of the soil under investigation, and $\Delta\varphi$ is the increase in friction angle.

By substituting appropriate data, the following friction angles are obtained: φ for non-reinforced soil and φ^* for reinforced soil. The shearing strengths τ_f and τ_f^* of non-reinforced and reinforced soils, respectively, have been calculated from the condition:

$$\tau_f = p_z \operatorname{tg}\varphi \text{ and } \tau_f^* = p_z \operatorname{tg}\varphi^* \quad (4)$$

In the formula (4), the value $p_z = q_{max} = 0.24$ MPa has been substituted according to the aforementioned assumption. Calculation results for the parameters φ , $\Delta\varphi$, and τ_f for loosely spilled sand are presented in table 5.

For the second case, that of reinforced soil, the destruction curve in the ordinate system of vertical p_z and horizontal p_y stresses is determined, according to [4], by the equation:

$$p_z = p_y \operatorname{tg}^2(45^\circ + 0.5\varphi) + p_0 \quad (5)$$

where

$$p_0 = 2c \operatorname{tg}^2(45^\circ + 0.5\varphi) \quad (6)$$

is an initial stress (i.e. when $p_y = 0$) signaling that reinforced soil behaves as if possessed anisotropic cohesiveness. The value of the cohesiveness c is maximal because the extreme stress state prevails. Model investigations provided a value of the term $p_0 = p_z^* - p_z = \Delta p_z$ (the effect of carrying capacity increase). The term p_0 (for various reinforcement types) and the friction angle $\varphi = 26.220$,

as determined for non-reinforced medium (table 5), were inserted into eq. (6), from which the cohesiveness effect c for individual types of reinforcement has been calculated. Next, the shearing resistance of reinforced soil has been obtained from the following formula, provided that we assume that the destruction mechanism for a soil sample consists in the slip of granular medium with respect to inserts:

$$\tau_f = p_z \operatorname{tg}\varphi + c = p_z \operatorname{tg}\varphi + p_0 [2c \operatorname{tg}(45^\circ + 0.5\varphi)]^{-1} \quad (7)$$

Table 5

Model	Positions of the nets	Parameters		
		φ [°]	$\Delta\varphi$ [°]	[MPa]
Non-reinforced	—	26.22	—	0.118
With single net	z_1	32.02	5.80	0.149
	z_2	32.49	6.27	0.152
	z_3	35.26	9.04	0.169
	z_4	39.05	12.83	0.194
	z_5	37.52	11.29	0.183
	z_6	35.79	9.57	0.172
	z_7	30.85	4.63	0.143
With two nets	z_1, z_7	36.69	10.47	0.178
	z_2, z_6	43.68	17.46	0.228
	z_3, z_5	49.79	23.57	0.283
With three nets	z_1, z_4, z_7	48.84	22.62	0.273
	z_2, z_4, z_6	55.91	29.68	0.353
	z_3, z_4, z_5	52.38	26.16	0.310

In the formula, the first term relates to non-reinforced soil and the second one is an addition that results from reinforcement.

Calculated values of cohesiveness c and shearing resistance for loosely spilled sand are presented in table 6.

Table 6

Model	Positions of the nets	Parameters	
		c [MPa]	τ_f [MPa]
Non-reinforced	—	—	0.117
With single net	z_1	0.019	0.137
	z_2	0.021	0.139
	z_3	0.033	0.151
	z_4	0.052	0.170
	z_5	0.044	0.162
	z_6	0.035	0.153
	z_7	0.015	0.133
With two nets	z_1, z_7	0.040	0.157
	z_2, z_6	0.083	0.201
	z_3, z_5	0.140	0.258
With three nets	z_1, z_4, z_7	0.130	0.248
	z_2, z_4, z_6	0.232	0.350
	z_3, z_4, z_5	0.174	0.292

6. Side pressure of various soils-results of comparative investigation

The comparative investigation has been carried out on coarse-grain sand (internal friction angle $\varphi = 29^\circ$), river gravel 5/10 and basalt grit 8/16 ($\varphi = 38^\circ$). It was aimed at an evaluation of the effect the granular medium type has on the formation of the reinforcement influence zone and its size. Following the rule that reinforcement should not lead to the medium delamination, a rigid steel-net reinforcement with square 16-by-16-millimeter mesh (designation S 16) has been employed in the investigation. Fig. 11 a shows the plots of side pressure in the non-reinforced medium. Fig. 11 b depicts the plots of side pressure in sand, gravel and grit, all both single-reinforced as well as double-reinforced.

The lower the internal friction angle of a given soil, the greater the effect of reinforcement on the side pressure reduction. For double-reinforced grit in the model investigated (plot 3 in Fig. 11 b), the optimal separation of S 16 inserts seems to be $\Delta z_{opt} = 0.12$ m (the curve between the levels z_3 and z_5 does not exhibit any convexity), while the respective plots for sand (1) and gravel (2) have a convex form in the zone discussed which suggests the value $\Delta z_{opt} < 0.12$ m (the reinforcement should be more dense). To sum up, the optimal reinforcement separation depends on the medium's internal friction angle.

7. Summary

Based on model investigation, an attempt has been made to assess the effect of reinforcement type (i.e. material, net mesh size), arrangement of inserts as well as the type and concentration of granular medium on the vertical range of the reinforcement-soil medium interaction zone.

The effectiveness of the net-like reinforcement with soil medium depends on the spacing of rods, rigidity of the net's material spatial arrangement (i.e. resistance to pulling out), the depth at which the interactions occur and physical properties of the medium.

For two-or multiple-insert reinforcements, such a relative position of the inserts, expressed in terms of vertical separation Δz , can be found which ensures the maximum side pressure reduction and thus the maximum possible effectiveness of the reinforcement action. In this particular case, the curve of unite side pressure between

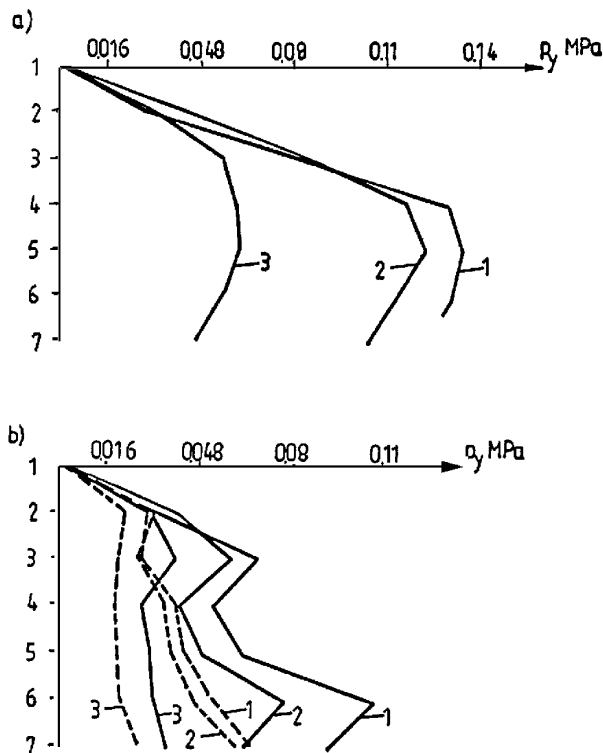

Fig. 11. plots of side pressure for three types of loosely spilled granular medium in the presence of load $q = 0.24$ MPa: a - non-reinforced medium; 1 - coarse grain sand; 2 - river gravel; 3 - basalt grit; b - reinforced medium: — with a single 16-by-16-millimeter steel net at level z_4 ; --- with two 16-by-16-millimeter steel nets at levels z_3 and z_5 ; 1 - sand; 2 - gravel; 3 - grit

consecutive insert levels exhibits neither convexity nor concavity and, presumably, the influence zones of inserting overlap.

The effect of reinforcement on the level of side pressure reduction is more pronounced if the internal friction angle for a given soil is lower. The optimum separation of inserts in a multilayer reinforcement is smaller in media with a lower internal friction angle. Values of strength parameters for the medium being modeled are closely related to the effectiveness of interaction between reinforced soil components, and thus with the effectiveness of reinforcing action, the latter being determined by the range of the "interaction zone".

References

- [1] JAROMINIAK A.; *Light retaining structures*, WKiŁ, Warszawa, 1999 (in Polish)
- [2] JAROMINIAK A., GAWOR B.; *Supporting structures made of soil reinforced with polyester resin/fiber glass*. Prace IBDiM nr 2, WKiŁ, Warszawa, 1989, pp. 87-159 (in Polish)
- [3] LEŚNIEWSKA D., KULCZYKOWSKI M.; *Design fundamentals for composite-reinforced soil structures*. Procedure IBW PAN, Gdańsk, 1995 (in Polish)
- [4] LONG N.T., SCHLOSSER F.; *Principle of operation and behaviour of reinforced soil*. Selected problems of geotechnology, Ossolineum, PAN-IBW, Wrocław, 1978, pp. 157-184 (in Polish)

- [5] LONG N.T.; *Investigation of reinforced soil*. Selected problems of geotechnology, Ossolineum, PAN-IBW, Wrocław, 1978, pp. 185-210 (in Polish)
- [6] LONG N.T., SCHLOSSER F.; *Dimensioning of reinforced-soil walls*. Selected problems of geotechnology, Ossolineum, PAN-IBW, 1978, pp. 211-237 (in Polish)
- [7] SAWICKI A.; *Statics of reinforced-soil structures*, IBW PAN, Gdańsk, 1995 (in Polish)
- [8] SCHLOSSER F.; *Reinforced soil in civil engineering*, Archiv. Hydrotechn., 1974, Vol. XXI, No. 2, pp. 299-336 (in Polish)
- [9] SUROWIECKI A.; *Experimental analysis of loose reinforced-soil carrying capacity*, Doctor's Thesis, Raport S.: PRE nr 64, Wrocław, 1984 (in Polish)
- [10] SUROWIECKI A.; *Laborversuche zum Einfluss ausgewählter Parameter auf die Wirkung der Bewehrung in lockeren Boden*, Bauingenieur, 1989, J. 64, Nr 5, pp. 215-217 (in German)
- [11] SUROWIECKI A.; *Laboruntersuchungen von mechanischen Eigenschaften bewehrter Bodenschichten*, Bautechnik, 1994, J. 71, H. 11, pp. 707-711 (in German)
- [12] WIŁUN Z.; *Fundamentals of geotechnology*, WKiŁ, Warszawa, 1989 (in Polish)