

Matej Kucera - Milan Sebok - Matej Kubis - Daniel Korenciak - Miroslav Gutten

ANALYSIS OF THE AUTOMOTIVE IGNITION SYSTEM FOR VARIOUS CONDITIONS

Paper presents diagnostic analysis of automotive ignition system for various working and adverse conditions in laboratory. Description and importance of basic diagnostics of automotive ignition system are examined in the first part of the paper. In the second the focus is placed on the basic principles and solution of the spark plug model. The test laboratory device is proposed in the following and the specialized measurements were executed by the proposed measurement system. The faults were simulated by application of oil and gasoline between the electrodes and failing by the driver to make the ignition contact on the spark plug.

Keywords: ignition system, conditions, diagnostics, measurement, LabVIEW

1 Introduction

Recent trends in the automotive industry lead to an increase in performance and a reduction in the production of pollutants contained in the exhaust gas, while simultaneously reducing the fuel consumption. This is also associated with a huge development in the field of ignition systems of internal combustion engines.

The ignition systems, even in their simplest form, represent an electrical system producing high voltage waveform in the form of complicated impulses. The essence of the fully electronic ignition system is to distribute high voltages for individual spark plugs for creating the ignition mixture.

Ignition systems are among the most important in the field of engine management, thus the great emphasis is placed on the diagnostics itself and determination of the exact failure [1].

Currently, the control circuits check the condition of electronic components, mainly by monitoring the voltage levels, calculating and estimating value limits during the diagnostic mode of the element. The diagnostics of these systems also requires diagnostic systems that allow to record these processes for further analysis. The current value of the jumping spark voltage in the individual cylinders must be determined by the separate switching control of the primary circuits of the high voltage transformers (spark ignition coils) [1-2].

The engine operating parameter signals are input to the control unit by means of which the control unit generates the control pulses for the end stages of the individual ignition coils. Operational parameter signals are needed to calculate the exact moment in which the high-voltage pulse has occurred.

Figure 1 shows an example of voltage and current waveforms of the transformer primary side.

The ignition coil (high voltage transformer) produces high-voltage pulses on the spark plug electrodes for ignited mixture in the combustion chamber of the engine (Figure 2) [3].

Conventional measurement diagnostic systems enable, based on the analysis of the primary and secondary high voltage waveforms, to evaluate measurement of the ignition systems for obtaining a more comprehensive overview of examined electric system [1].

Diagnostics of the ignition systems using the conventional diagnostic systems enables, based on analysis of the primary and secondary high-voltage waveforms, to detect failures in the diagnostics of the measurement system under examination. When locating the fault states of electronic ignition systems, possibilities of the non-destructive diagnostics of ignition systems, based on voltage, current or thermo-vision analysis, are analyzed, as well [4].

2 Theoretical analysis

The distributorless ignition system (DIS) is an ignition system, which distributes high voltage to each spark plug without using the mechanical distributor. The high voltage shall be achieved to create a spark at the spark plug igniting the mixture through a high-voltage coil (transformer). The high-voltage outlets in the distributorless ignition system are directly applied to plugs, thus increasing the number of ignition coils [5].

Matej Kucera, Milan Sebok, Matej Kubis, Daniel Korenciak, Miroslav Gutten*

Department of Measurements and Applied Electrical Engineering, Faculty of Electrical Engineering and Information Technology, University of Zilina, Slovakia

E-mail of corresponding author: miroslav.gutten@uniza.sk

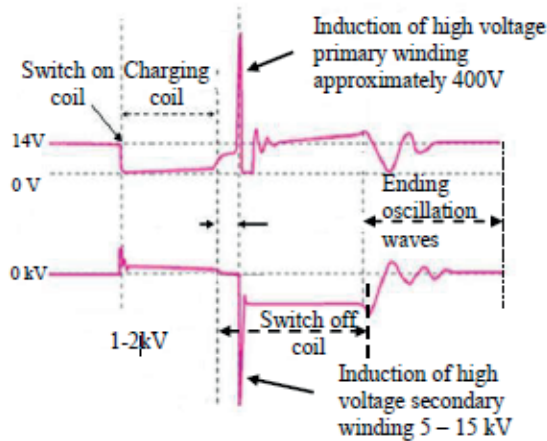

Figure 1 Voltage waveforms of the primary side of the transformer winding

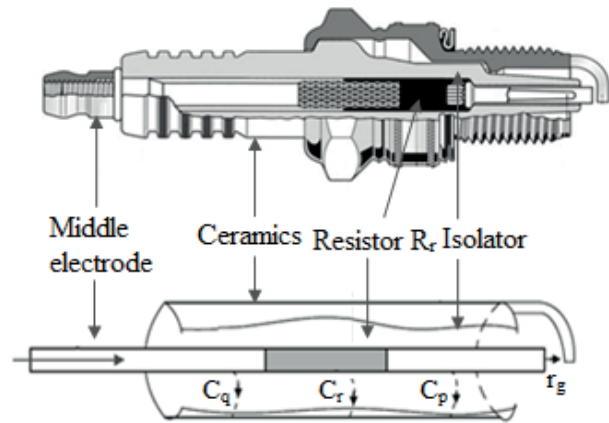

Figure 2 The spark plug model

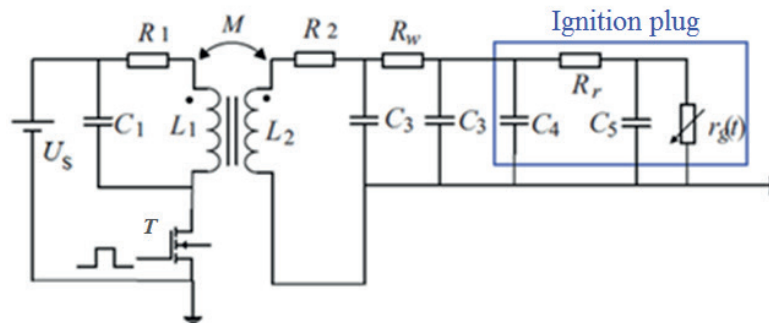

Figure 3 The replacement model of the ignition assembly

An immediate flashover in the cylinders must be determined by a separate switch controlling the transformer primary circuits.

The ignition system is equipped by an ignition module (high-voltage transformer), power electronics (transistors with protective circuits) and a spark plug. The ignition system is controlled by generating signals by the control unit, which are led to the power module. Based on the signals, the transistors are opened, thanks to which the current flows through the primary side of the ignition transformer. When the transistor is closed, the energy is transferred from the primary side to the secondary side. Modelling of the spark plug during the discharge of the ignition transformer is problematic. The current passing between the electrodes is the dominant ignition current. The corresponding spark plug design is shown in Figure 2, [5-6].

A replacement model of the ignition assembly is constructed by using the Figure 3 spark plug model, where R_r is a series resistance and its value depends on the design solution, r_g is the spark plug air gap resistance, and C_q , C_r and C_p are parasitic capacitances between the middle electrode and the sheath.

The following equations can be derived from Figure 2

$$C_4 = C_q + \frac{C_r}{2}, \quad C_{45} = C_p + \frac{C_r}{2}, \quad C_3 = \frac{C_w}{2}. \quad (1)$$

The DC power supply voltage is marked U_s , R_1 and R_2 are respectively the primary and secondary winding resistances, L_1 and L_2 are respectively the primary and secondary winding inductance, R_w is the high-voltage conductor resistance and M is the mutual inductance coefficient between the primary and secondary sides. It is obvious from the replacement ignition circuit that the transition from the steady state is associated with a change in the electromagnetic energy $W(t)$ in the circuit [7-8].

This energy is accumulated by the electric field of the capacitor and the magnetic field of the inductor

$$W(t) = \sum_{k=1}^{n_1} W_{ek}(t) + \sum_{k=1}^{n_2} W_{mk}(t), \quad (2)$$

where n_1 is the number of capacitors and n_2 is the number of coils.

3 Test laboratory device

Currently, the control circuits check the condition of electronic components mainly by monitoring the voltage levels, calculating and estimating value limits during the diagnostic mode of the element.

In order to evaluate the correct operation of the ignition system, it is necessary to check the time course of the voltage and current of the high-voltage

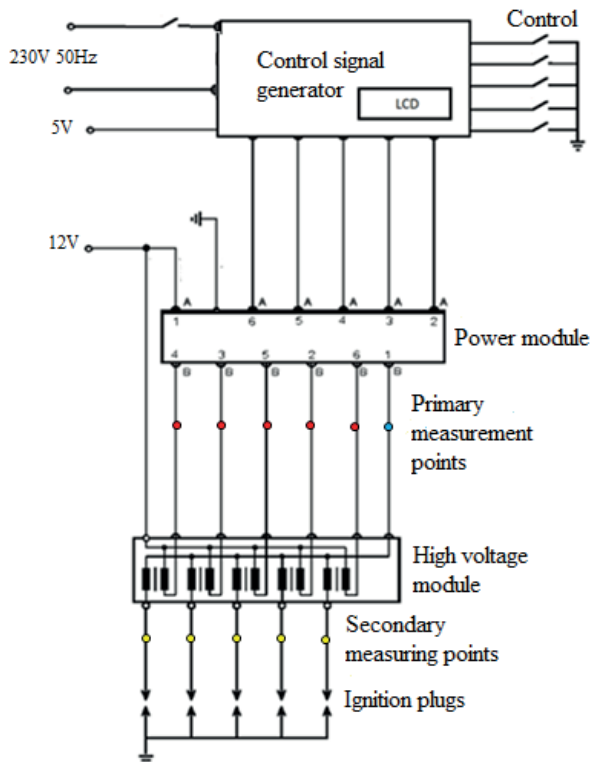

Figure 4 Ignition system wiring diagram

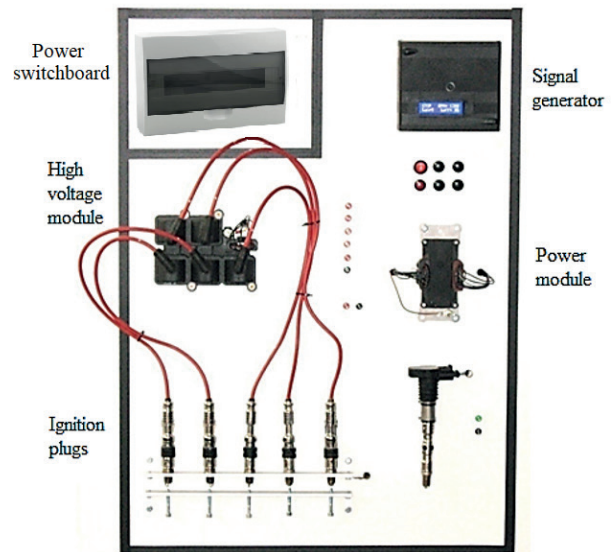

Figure 5 The ignition system test equipment

module by measurement., It is possible to determine the state of the ignition system and to determine the reduced functionality by measuring and evaluating the characteristics.

A laboratory device has been created to obtain the necessary signals. The device allows for creating the fault states and monitoring changes in output characteristics. Based on this device, it is possible to physically simulate possible faults, copy them to a database and compare them to the actual ones in the car based on files.

Figure 4 shows a wiring diagram of a test device that includes a control signal generator, power module, high voltage module and spark plugs. The diagram also contains measuring points for direct connection of oscilloscope and capacitive probe.

The signal generator replaces the motor control unit in a simplified form. It is a programmed 8-bit microprocessor DC9S08QE. It is possible to activate the generator by use of buttons and change the time intervals during which the energy accumulates on the primary side of the ignition coils.

For information on the set signal generation mode, the generator also includes an LCD display. The signal generator allows generating a switch-on time t_{on} ranging from 0 to 9 ms and a switch-off time t_{off} between 10 and 500 ms in 1 ms steps. Generation is performed for five channels. The display unit shows the mentioned times, the generator activation status and the estimated four-stroke engine speed. The generator produces 5 V voltage levels. The output circuits contain opto-couplers for galvanic isolation. The power module converts the low-

power 5 V voltage signals to power. It is powered from a 12 V power supply. The component contains a charging current limitation, which can also be seen in the current characteristics.

The current limitation is to prevent the ignition coil from being supersaturated. The high voltage module is a block containing the high voltage ignition coils. They are voltage transformers whose primary tents resistance is approximately 1.5Ω and secondary 5-10 k Ω . The primary sides of the coils are connected all together to the 12 V voltage and by means of transistors the connection is made to the ground (vehicle ground).

Spark plugs must be designed to withstand the aggressive working environment of the combustion chamber and to ignite the mixture. Ignition of the fuel mixture is accomplished by creating an electric arc between the contacts. Connection between the high voltage module and spark plugs is made by the high voltage conductors with increased resistance from 5 to 10 k Ω .

Spark plugs also have an increased resistance, which amounts to 3 to 6 k Ω , depending on the design type. As the temperature rises, the plug resistance decreases. The measuring points are placed in such a way that important signals can be detected, which give information about the state of the ignition system. The constructed device is shown in Figure 5.

The device allows to create fault states in individual blocks, which also affects the change of electrical quantities, which can be subsequently measured and evaluated.

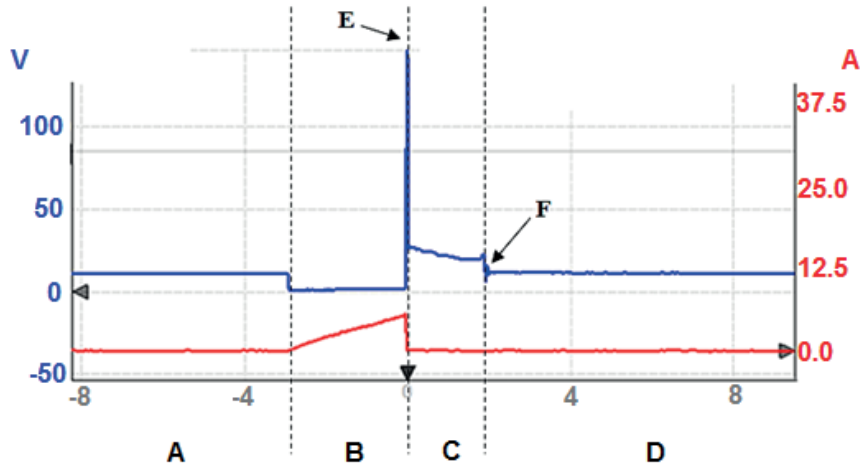

Figure 6 Current and voltage waveforms on the primary side of the ignition module:
 A - ignition module inactivity, B - energy storage interval, C - arc burning time, D - ignition module inactivity,
 E - Initialization of the arc burning, F - ignition transformer oscillations.

4 Processing of results

Let the time behaviour be considered as a measurable quantity. If that signal is then compared to the desired signal, one can evaluate the residue based on the difference. Failure assessment, using a residual assessor, not only allows detecting the component failures but can provide information about the component degradation. The best solution for detecting a failure and possibly making a component prognosis is to monitor the behaviour course of the arc burning on the spark plug. By measuring the voltage on the primary or secondary side one obtains information about the arc burning or eventually the inactivity of the ignition system.

Figure 6 shows the current and voltage waveforms on the primary side of the ignition module for the set interval $t_{on} = 3$ ms. The voltage characteristics shows influence of the secondary side, where it is possible to observe the initial impulse for arc formation and burning time, which in this case is approximately 2 ms.

By using the ADC converter of the engine control unit to monitor the signals on the primary side of the ignition module and then applying a suitable algorithm, it is possible to increase the diagnostics of the ignition system. If one observes the signal in the interval A (or D,) one can evaluate whether the primary winding of the ignition module is damaged by interruption or whether the supply voltage has been disconnected. During the energy storage period B, the transistor in the power module opens. At this interval, the voltage is equal to the voltage drop across the transistor. The current increases depending on parameters of the ignition transformer. By evaluating the current increase and the maximum value, it is possible to determine the short in the winding, which would result in a change in inductance and a decrease in series resistance.

The interval C is essential for determining the arc burning condition. If there was a significant failure during A and B, there would be no burning interval. In this mode, the transistor is closed and the energy stored on the primary side of the ignition coil is transferred to the secondary part. Voltage greater than 10 kV is required for the initial combustion of the arc in the combustion chamber. This voltage is more than a hundred volts on the primary side. Each diagnostic system works by evaluating the measured signals in certain modes and comparing them to the desired signals [9-10].

According to Figure 7 the waveform can be divided into six periods, which are then mathematically spread (interval t_1 until t_6):

$$\text{Interval } t_1: \quad u(t) = 0$$

$$\text{Interval } t_2: \quad u(t) = l \cdot \cos(n \cdot t) e^{-d \cdot t}$$

l - voltage in the steady state is voltage constant,

n - determines the number of amplitudes,

k - amplitude,

d - specifies the attenuation.

$$\text{Interval } t_3: \quad u(t) = a \cdot t + c_1$$

a - is a constant of the line inclination,

c_1 - determines the initial state (final state in the interval t_2).

$$\text{Interval } t_4: \quad u(t) = \frac{1}{b\sqrt{\pi}} \cdot e^{-t^2/b^2} + c_2$$

b - amplitude constant,

c_2 - determines the initial state (final state in the interval t_3).

$$\text{Interval } t_{5:1}: \quad u(t) = -m \cdot t + c_3$$

m - is a constant of the line inclination,

c_3 - determines the initial state (final state in the interval t_4).

$$\text{Interval } t_{5:2}: \quad u(t) = k \cdot \cos(n \cdot t - h) e^{-d \cdot t} + c_4$$

n - determines the number of amplitude,

d - specifies the attenuation,

h - shift of course,

c_4 - determines the initial state (final state in the interval t_5).

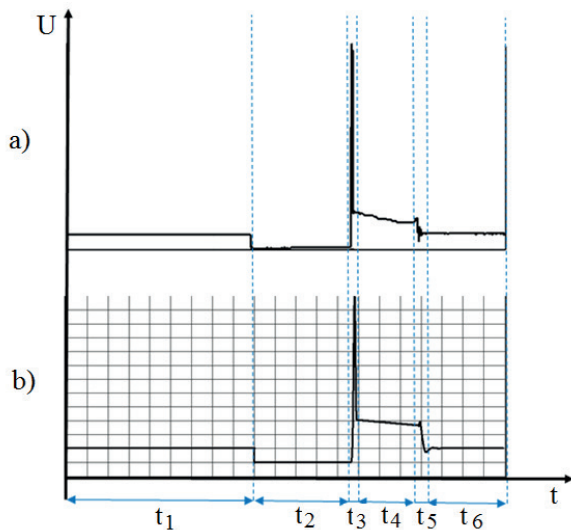

Figure 7 Voltage waveform on the primary part of the ignition module: a - real, b - simulated

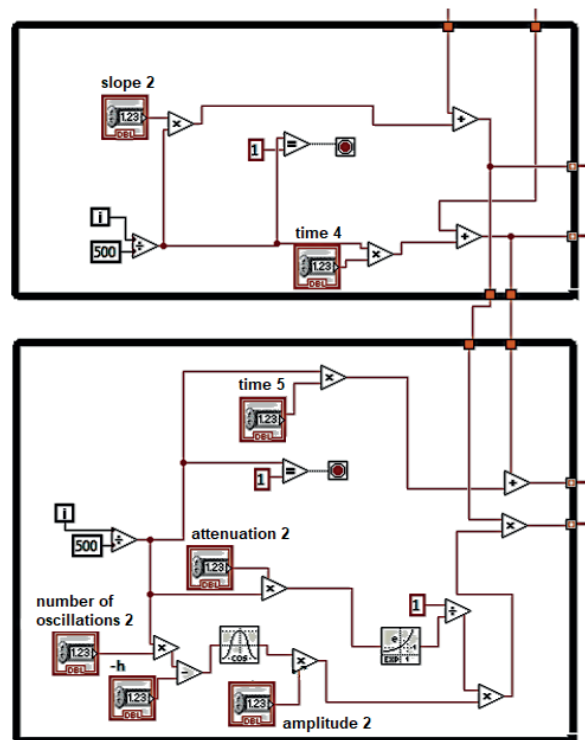

Figure 8 Part of the block diagram from LabVIEW to simulate intervals t_4 , t_5 and t_6

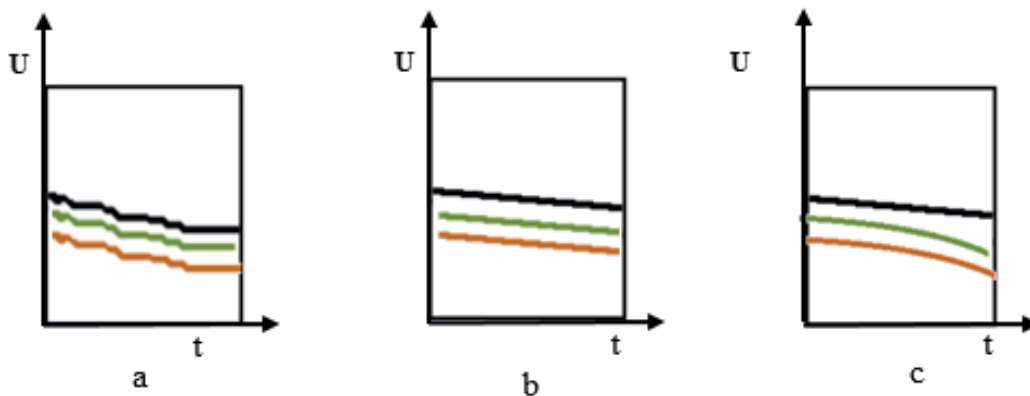

Figure 9 Arc burning interval t_4 with tolerance zones: a - real, b - simulated, c - simulated with adjusted tolerance zones

Voltage simulation was created in LabVIEW environment (Figure 8), where individual time periods are described by mathematical functions.

For a deeper analysis, a simulation by programming environment NI Labview in mathematical mode can be used, where one can set up such operations during the subsequent simulation of error conditions spark pulses through the mathematical model, Figure 8.

LabVIEW allows to export the simulated waveform to a spreadsheet program. Thus, the waveform can be used as a reference for signal testing. If one can determine the reference course of combustion, one can then further introduce tolerance zones to detect partial and permanent failure [11].

The first tolerance band may be for detecting a partial fault (Figure 9 green).

The second tolerance zone (orange color) is intended to determine the inactivity of the ignition system. At least two measurements should be made during the intervals depicting the arc burning. The length of the arc burning is almost 2 ms. In about 0.5 and 1.5 ms. for the built-in online diagnostics, a test cycle would also have to be created, allowing for example to be checked only after the car has warmed up to operating temperature and partially loaded at medium engine speed with a minimum of 5 test cycles over 10 minutes.

Figure 10 illustrates the sampling of arc burning that must be performed from time t_0 . It is possible to realize only one measurement at time t_{22} , which is sufficient for the arc burning evaluation.

In Figure 11 is presented a sequence program of high voltage waveform ignition model EFS with a faulty diode

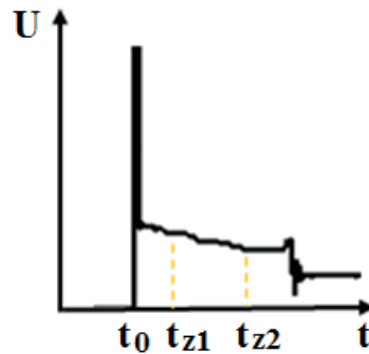

Figure 10 Arc burning interval with two sampling points

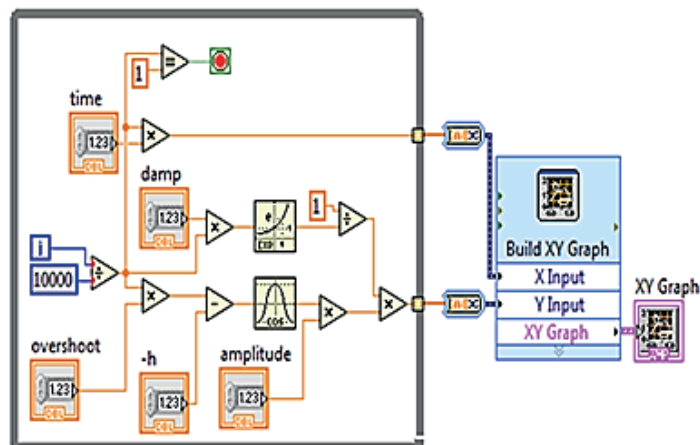

Figure 11 The program sequence in Labview

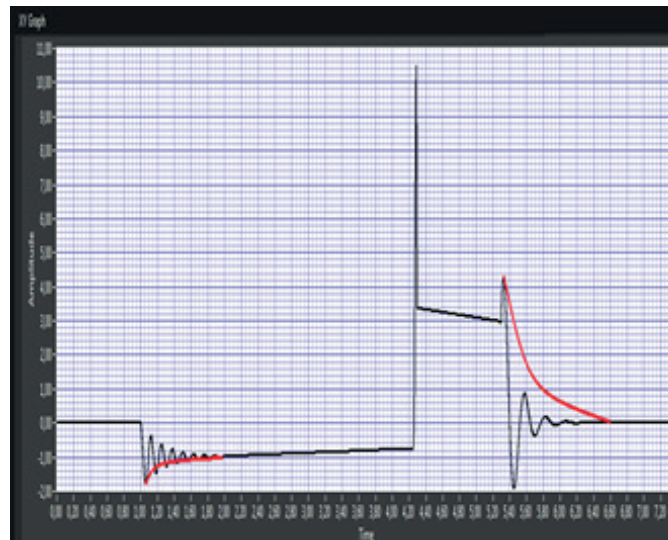

Figure 12 Simulating spark waveforms during the correct and incorrect operation

and simulation graph in Figure 12., It shows comparison of the malfunctioning ignition coil - sinusoidal course with decreasing amplitude at switching on the primary part of transformer and switching off secondary part of transformer the shutdown transformer (faulty diode) and graph with the end of burning sparkle with-out damped oscillations (correct operation of the ignition coil).

5 Measured results with simulated faults

The measurement was performed at atmospheric pressure and on a four-electrode spark plug. The oscilloscope sampling was set to 100 kS/s (time between samples is 10 μ s). The transformer charging phase was set to 6ms. The measurement was repeated and recorded five times. Figure 13 is a characteristics,

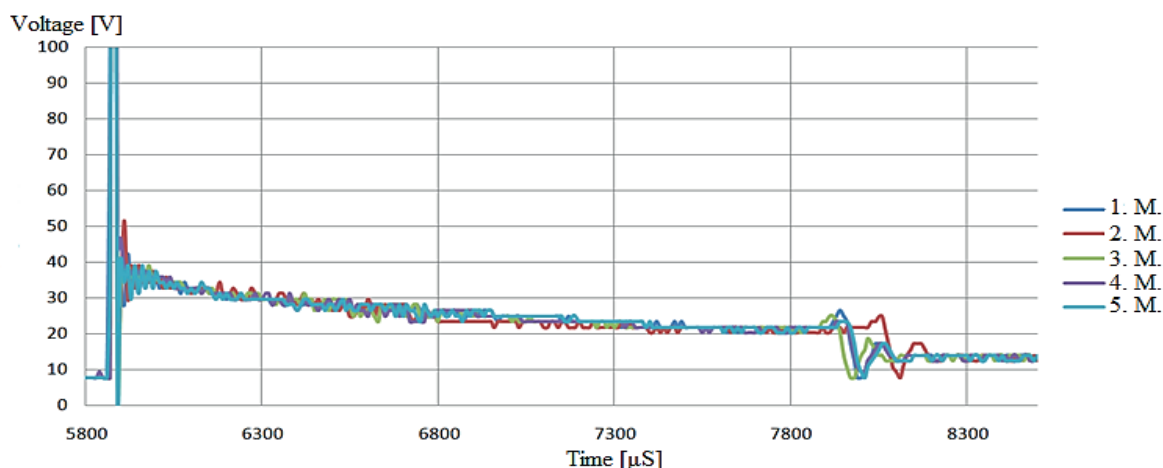

Figure 13 The course of voltage during the arc burning

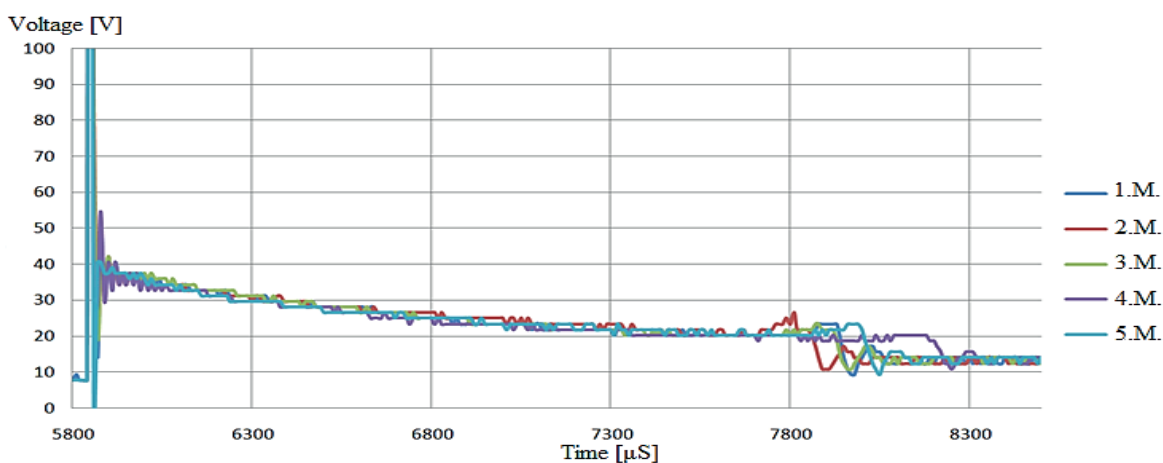

Figure 14 The course of voltage during the arc burning by applying gasoline

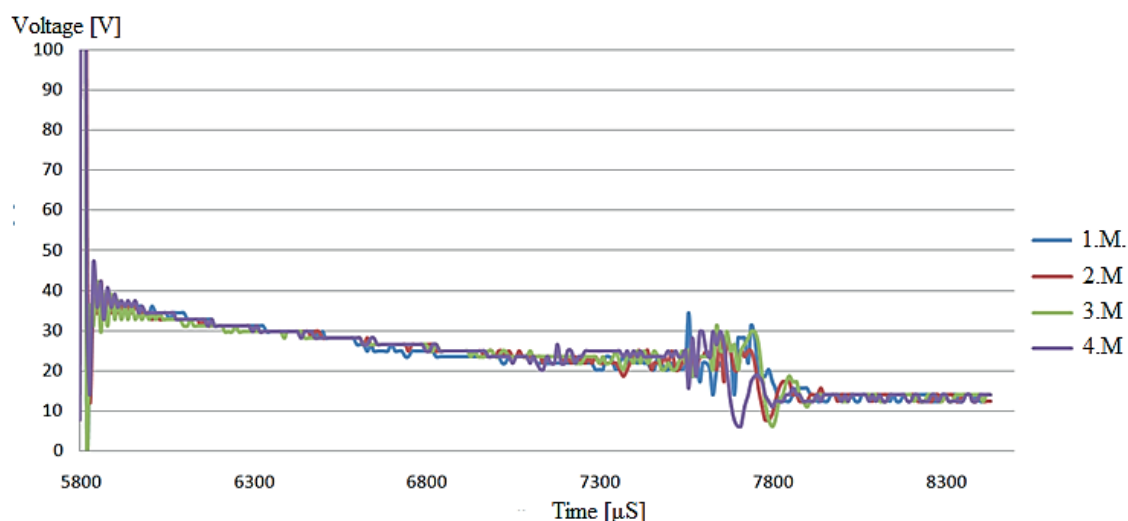

Figure 15 The course of voltage during the arc burning by applying oil

showing the voltage on the primary side of the ignition module.

By applying a small amount of gasoline to the spark plug, the arc fading scattering occurred (Figure 14). Petrol changed the air gap properties between the electrodes.

The oil was more radical in the characteristic (Figure 15). The reverberation of the arc burn was more oscillated, and the burn time was also reduced by $250 \pm 100 \mu\text{s}$.

Figure 16 shows a simulated failure of the ignition contact of the driver to the spark plug. The gap distance

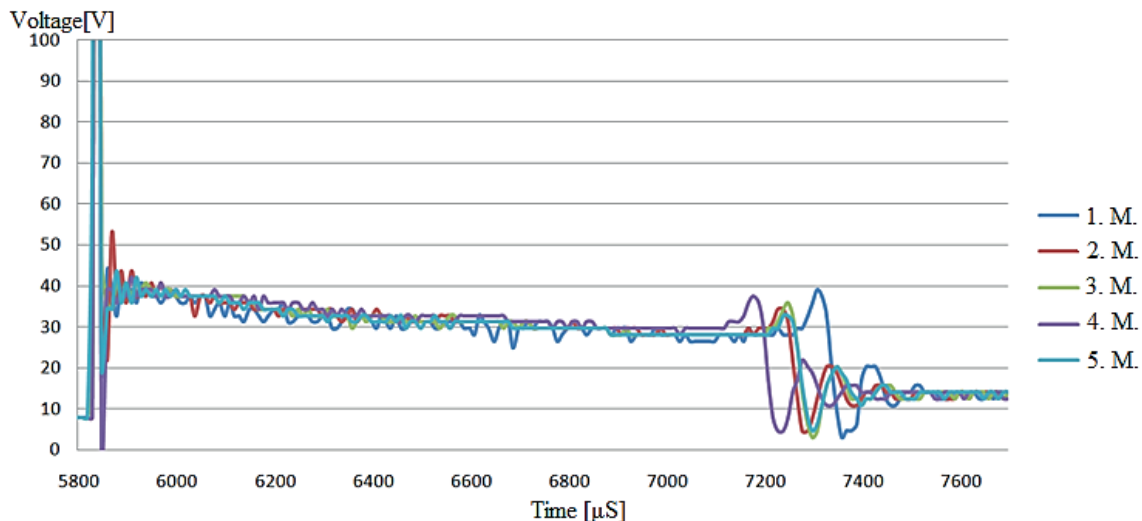

Figure 16 The course of voltage during the arc burning with failure

was $400 \pm 100 \mu\text{m}$. Burning time was reduced by $750 \pm 150 \mu\text{s}$. During the burning, the voltage was for about 10 V higher. Higher overshoot was reflected in the decay of the arc, as well.

6 Conclusion

Diagnostics of ignition systems by diagnostic systems allows measurement of the primary and secondary high-voltage waveforms. Programming environment of Labview allows to evaluating adequately the waveforms to obtain a comprehensive overview of the examined system based on the simulation analysis.

Ignition system with dual spark coils represents a simple variant without mechanical distribution of ignition. The negative aspect is the limitation of time adjustment due to the exhaust sparks.

A device was designed on which one can test individual components of the ignition systems, monitor

their functionality and measure the influence of the ignition arc on different components. Based on this device, it is possible to physically simulate possible faults, copy them to a database and compare them to the actual ones in the car based on files.

Measurements have elucidated the phenomena and effects that affect the arc burning. After the application of oil and gasoline between the electrodes and the failure of the spark plug connection, the time characteristics of the voltage differed from the base. The most significant differences were found during the arc burning with failure.

In the abovementioned analysis of the voltage waveform, when the spark burns out, it is evident that the finishing phase of the burning sparks is missing and instead of damped oscillations course gradually declined. This effect is caused by the high-voltage diode. If a spark goes off, the current stops flowing in the secondary circuit and diode closes and electrically disconnects the secondary circuit section.

References

- [1] BOSCH, R. Automotive handbook. 8 ed. 2011. ISBN 0837616867.
- [2] SPANIK, P., SEDO, J., DRGONA, P., FRIVALDSKY, M. Real time harmonic analysis of recuperative current through utilization of digital measuring equipment. *Elektronika ir Elektronika* [online]. 2013, **19**(5), p. 33-38. ISSN 1392-1215, eISSN 2029-5731. Available from: <https://doi.org/10.5755/j01.eee.19.5.4364>
- [3] MRUZEK, M., GAJDAC, I., KUCERA, L., BARTA, D. Analysis of parameters influencing electric vehicle range. *Procedia Engineering* [online]. 2016, **134**, p. 165-174. ISSN 1877-7058. Available from: <https://doi.org/10.1016/j.proeng.2016.01.056>
- [4] LI, X., LU, X., HAN, G. The design and simulation research of Mazda6 hybrid electric vehicle. *Przeglad Elektrotechniczny*. 2012, **88**(3b), p. 44-47. ISSN 0033-2097, eISSN 2449-9544.
- [5] WANG, Q. Circuit model and parasitic parameter extraction of the spark plug in the ignition system. *Turkish Journal of Electrical Engineering and Computer Sciences*. 2012, **20**(5), p. 805-817. ISSN 1300-0632. Available from: <https://doi.org/10.3906/elk-1009-751>
- [6] JIA, J., WANG, Q., YU, J., ZHENG, Y. Wideband equivalent circuit model and parameter computation of automotive ignition coil based on finite element analysis. *Application Computational Electromagnetics Society Journal*. 2010, **25**, p. 612-619. ISSN 1054-4887.

-
- [7] MURPHEY, Y. L. Automotive fault diagnosis - part II: a distributed agent diagnostic system. *IEEE Transactions on Vehicular Technology* [online]. 2003, 52(4), p. 1076 - 1098. ISSN 0018-9545. Available from: <https://doi.org/10.1109/TVT.2003.814236>
- [8] FAN, S. Fault diagnosis of vehicle electric/electronic devices based on electronic coordination. In: International Conference on Electronics, Communications and Control ICECC 2011: proceedings. 2011. ISBN 9781457703201, p. 2053-2056.
- [9] HALDERMAN, J. D. *Automotive technology: principles, diagnosis, and service*. 5. ed. Pearson. ISBN-13: 9780133994612, p. 153-168.
- [10] CHEN, L., ZHANG, Z. Study on the measurement of dynamic characteristics for automotive electronic fuel injector. In: International Conference on Transportation, Mechanical, and Electrical Engineering TMEE 2011: proceedings. 2011. p. 511-514.
- [11] KANUCH, J., FERKOVA, Z. Simulation stepping motor with DISC rotor. In: International Conference on Low Voltage Electrical Machines: proceedings. 2010.