

Juraj Gerlici - Mykola Gorbunov - Kateryna Kravchenko - Olga Prosvirova - Tomas Lack*

THE INNOVATIVE DESIGN OF ROLLING STOCK BRAKE ELEMENTS

The paper deals with traffic safety in railway transport. The influence of the work of the braking system friction elements on braking performance is evaluated. The temperature in the pad-on-disc or pad-on-wheels contact has significant influence on the friction brake elements. Important factor in achieving maximum braking power is the control of the temperature in the contact. The analysis of methods and designs for heat dissipation from contact friction elements is carried out. The effect of ventilation channels of disc brakes on the vehicle running resistance is considered. The technical solutions for temperature control in friction elements during braking are proposed. Based on the analysis, an innovative solution of the brake disc was proposed. The proposed solution will reduce the wear of the friction surfaces, will significantly simplify the technological process of the brake disc replacement, will reduce the probability of cracks in the depth of the disc and will increase the reliability of its operation.

Keywords: Brake elements, temperature stabilization, ventilated disc, porophores, phase transition, wound up disc.

1. Introduction

The efficiency of friction elements of the rolling stock brake system has a significant impact on traffic safety and possibility of speed increase. This helps to improve freight capacity and throughput [1 - 5].

During braking, kinetic energy of the train is transformed into other forms of energy, mostly to heat. This process is accompanied by increase in the friction element temperature. Effective braking depends on the friction coefficient, which is influenced by temperature changes in the friction contact. Accordingly, the topical issue in the rolling stock operation is stabilization of the temperature in the braking element interaction zone [6 - 7].

Due to the friction forces wheel and brake pads contact is heated up during braking. This adversely affects the surface of the wheel rolling (the temperature in the contact zone reaches 700 - 800 °C) [2 and 8]. It is proven that the heat load is inversely proportional to the disc and pad interaction square. A temperature field with a significant gradient is an indispensable overwhelming physical phenomenon of mechanical energy into heat conversion. This leads to decline in friction and strength properties due to structural changes in materials. Prolonged exposure to high temperatures promotes the release of thermal cracks into the outer surface. Due to high temperature friction the surfaces of brake elements wear relatively quickly. The rate

of wear is determined by the occurrence and development of high temperatures in the friction zone [9]. The increasing temperature of the brake disk can lead to its deformation and surface misalignment. Thermal deformation in the rib area causes the waviness or roughness of the friction disc surface, thereby increasing the pressure on the friction linings and creating local temperature spots on the friction disc surface [10].

2. Temperature control methods of tribo-loaded brake elements

Providing stabilization of friction element operation is a multifaceted problem which cannot be solved by the application of a single method. It requires solutions of technical-economic, technological, metallurgical, and tribological tasks.

To solve this problem, combinations of various methods have to be implemented (ceramic discs with high temperature resistance, perforation application, etc.) and cooling air has to be supplied. In designing brake elements for means of transport, following methods for temperature control of friction pairs are currently implemented [1 - 2, 6 - 8, and 10 - 18]:

1. Temperature control based on heat absorption or release by metallic or non-metallic friction elements of brakes.

* ¹Juraj Gerlici, ²Mykola Gorbunov, ¹Kateryna Kravchenko, ²Olga Prosvirova, ¹Tomas Lack

¹Department of Transport and Handling Machines, Faculty of Mechanical Engineering, University of Zilina, Slovakia

²Department of Rail Transport, Institute of Transport and Logistics, Volodymyr Dahl East Ukrainian National University, Ukraine

E-mail: juraj.gerlici@fstroj.uniza.sk

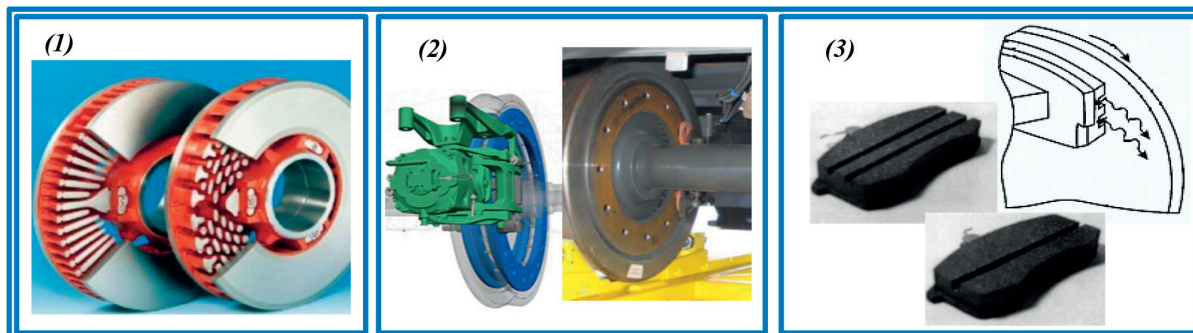

Fig. 1 Ventilated brake components used in railway transport:

1 - vented brake discs mounted on the wheelset axle; 2 - vented brake discs installed on the wheel; 3 - brake pads with ventilation holes [11]

- Chemical reactions in materials of the friction pads with the release or absorption of heat.
- Effects of allocation and energy absorption by changing the friction elements physical state (melting, evaporation, sublimation, crystallization, etc.).
- Physical properties of the friction element materials that provide high heat transfer.

2. Temperature control based on heat removal from the friction elements to the environment (Fig. 1).

- Ventilation and self-ventilation (Fig. 1).
- Heat removal with special cooling elements.

The method of air flow cooling is often implemented for high speed rolling stock using disc brakes. Cooling air flow passes through special elements of the brake disc designed for this purpose. Well-known are brake discs designed, for example, for inter-regional transport KVZ-TSNII [12] made from malleable cast irons. Every brake disc consists of two cast iron discs connected with radial ventilation ribs. Ventilation ribs provide cooling air flow during the train running. To enhance braking performance on the U. S. Railroads, discs made from manganese steel with 10 - 14% manganese content were used; in Germany steel discs with hardened friction surfaces were used [12].

According to the research performed by S. I. Damdin [10], thermal energy generated during braking is released into the atmosphere with the help of coolant. This solution provides an acceptable operating temperature for bearings and lubrication of friction pair elements, which increases the durability of the disc and friction material.

The teams working for the open joint stock company “Scientific-research and design technological institute of asbestos technical products – TIIR” offer an improved design of railway brake pads [13] to reduce temperature differences. It meets this aim by placing a flat element made of material having a smaller coefficient of linear thermal expansion than the polymer of the friction material in the surface layer of the rear side pads. This solution allows for reducing thermal stresses in the surface layer

at periodic heating and cooling making use of unequal thermal expansion of individual sections of the pad.

Innovative methods which can be implemented in modern braking systems in the future are as follows:

- forced air flow supply into the contact area of two friction elements;
- forced air supply with temperature control depending on conditions and modes of operation;
- pads with porophore inserts;
- pads with cooling ribs;
- brake pads with outer surface covered with heat dissipating material;
- friction activator supply to the friction contact zone;
- brake elements with phase transition material inserts.

3. Impact assessment of vehicle movement resistance caused by disc brake operation

The most common construction solution for ensuring stable operation of the brake elements is the use of ventilated discs (Fig. 1). The main advantage of these designs is the cooling surface of the disc when braking up to a certain speed. The disadvantages include the movement resistance from the ventilation channels.

At vehicle’s high speeds the brake disc vent blades create additional resistance to movement, which leads to certain losses of locomotive power capacity, especially for high-speed locomotives, for which the resistance increases due to significant speeds. So 3000 - 4000 m³/h of air that cools the disc is pumped through the ventilation channels. This leads to costs that depend on the rolling stock speed and length, number of discs on the wheelset axis. For example, according to the research performed by A. I. Turkov [1], diesel trains of DR-type which were equipped with sets consisting of eight brake discs will consume for self-ventilation 19.1 kW at the speed of 200 km/h. Electric trains of ER-type will consume 48 kW for self-ventilation. For diesel train DR1 total power is reduced by 2.6%. The study presented in the Table 1 shows that for modern high-speed trains, this number increases several times.

The study presented in Table 1 was carried out according to the formulas of A. I. Turkov, derived for the two designs of ventilated discs used for diesel train DR-1 and electric trains ER. For the trains listed in the Table 1 these types of discs lead to power loss ranging from 1% to 23% depending on the disc construction, their quantity, and train speed.

All the energy which is produced by the traction vehicle is used to overcome the forces of resistance and forces of inertia. Annually a large amount of fuel and electricity is spent for traction; its cost significantly affects the cost of transportation. Therefore, drag reduction is as important as improving the efficiency of traction of the vehicle. Reducing the resistance allows to increase the rolling stock weight or speed for the same locomotive, to reduce wear and repair costs. The problem of motion resistance reduction is directly related to the need for aerodynamic optimization of rolling stock. For safe operation it is necessary already in a designing stage to consider the elements which prevent air flow entering the ventilation channels during the vehicle movement.

4. Technical solution for eliminating self-ventilation of disc brakes during a vehicle running

To eliminate the self-ventilation of the disc brakes resulting in the vehicle resistance against movement and against the startup of a standing vehicle, it is necessary to close the ventilation channels of the disc brakes. The developed disc brake design contains elements for closing the ventilation openings during the movement. This phenomenon is achieved by the design illustrated in Fig. 2. During the movement, the shape memory alloy plates (Fig. 2) [14] located at each vent blade, block the ventilation ducts. During braking, the temperature of the brake disc rises. Under high temperature the material of the plate shifts from the martensitic state T_M to austenitic T_A (Fig. 2). This changes a crystal lattice and a shape of the plate. The angle of inclination α of the plate to the ventilation blade decreases from 90° to 0° and the ventilation channels open. Under the action of centrifugal forces the air in the ventilation ducts moving from the brake disc center to its periphery in the radial direction, as a result, forms the ventilation air flow that removes heat from the disc.

Analysis of the brake discs influence on the train power loss

Table 1

l	Manufacturer	Train Series	Power output, P, kW	Speed, v, km/h	Aerodynamic (pumping) power loss for one brake disc Q_{aerod} kW	Aerodynamic (pumping) power loss for all brake discs of the train $\sum Q_{aerod}$ kW	Loss of power train due to operation of disc brakes, %
1	2	3	4	5	6	7	8
1	Alstom	TGV POS	9 280	320	3.15*	88.15*	1*
					25.21**	705.98**	8**
2	Siemens	CRH380B	9 200	350	3.83*	245.39*	3*
					32.99**	2111.40**	23**
3	Talgo Bambordier	AVE Class 102	8 800	330	3.37*	141.48*	2*
					27.65**	1161.39**	13**
4	Hitachi Kawasaki Nippon Sharyo Tokyo Car	E2 SERIES SHINKANSEN	9 600	275	2.26*	180.44*	2*
					16.00**	1280.19**	13**
5	Alstom	ED250 Pendolino	5 664	200	1.12*	47.01*	1*
					6.16**	258.54**	5**
6	Hitachi	BR Class 395	3 360	225	1.45*	69.62*	2*
					8.76**	420.70**	13**
7	Hyundai Rotem	KTXIII	9 840	350	3.83*	184.04*	2*
					32.99**	1583.55**	16**

* when calculating the formula according to Turkov: $N_{v2} = 0.1624 \cdot V^{2.2}$;
 **when calculating the formula according to Turkov: $N_{v3} = 0.03594 \cdot V^3$

Due to limited information we assume that all types of bogies will have wheelsets equipped with two brake discs. Though in operation, one wheelset can have more brake discs.

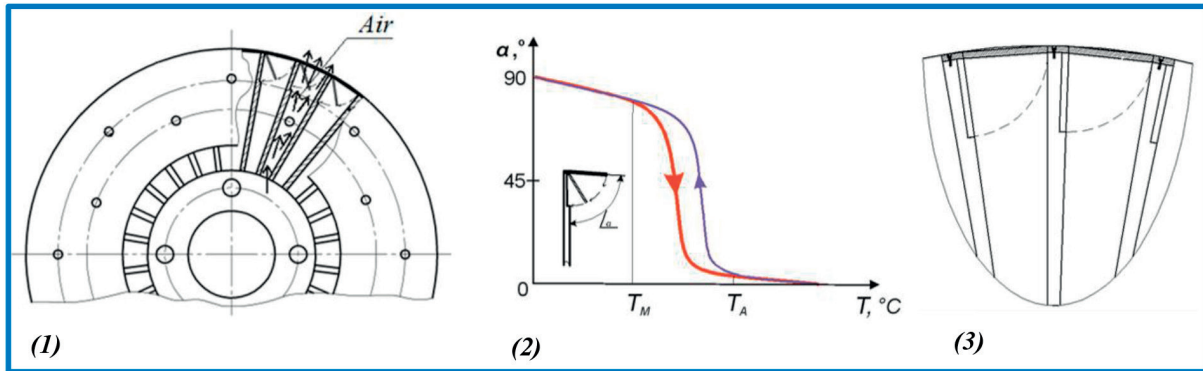

Fig. 2 Technical solutions to reduce the energy costs of high-speed trains

1 - the circulation of air in the brake disk; 2 - changing the angle of inclination of the plate to form a storage depending on the temperature; 3 - location plates with shape memory material on the blades of the brake disk

When the brake disc cools, the reverse occurs - the plate material passes from the austenite state to martensite. When the plate temperature reaches martensitic condition T_M it flexes, taking the original position (90°) - the ventilation channels close (Fig. 2); this reduces the additional power cost caused by airflow in the ventilation ducts of the brake disc during movement.

Thus during movement the ventilation channels are closed and during braking they are open. Upon the brake disc reaching ambient temperature, the plate returns to its initial position. In this case the ventilation channels are closed until the next braking.

5. Innovative design of rolling stock brake elements

The disadvantages of the known brake disc constructions include:

- The complexity of brake disc replacement for the use in railway transport. When the disc is to be replaced and a standard brake disc is placed between the wheels of the wheelset, it is necessary to press both the wheel and the disc from the axle. Then both a new disc and wheel are pressed on the axle.
- High brake disc replacement costs.
- Insufficient cooling of the contact surface.
- Crackles.

To eliminate these disadvantages and take advantage of the known disc structures an innovative brake disc design is proposed [15]. The main idea of the design is making the disc in the form of two wound plates, one of which is frictional the other is heat removing (Fig. 3). The brake disc is formed by winding and fixing these plates on the wheelset axis. A strip of the outer contact plate side has projections for cooling on the outer, and

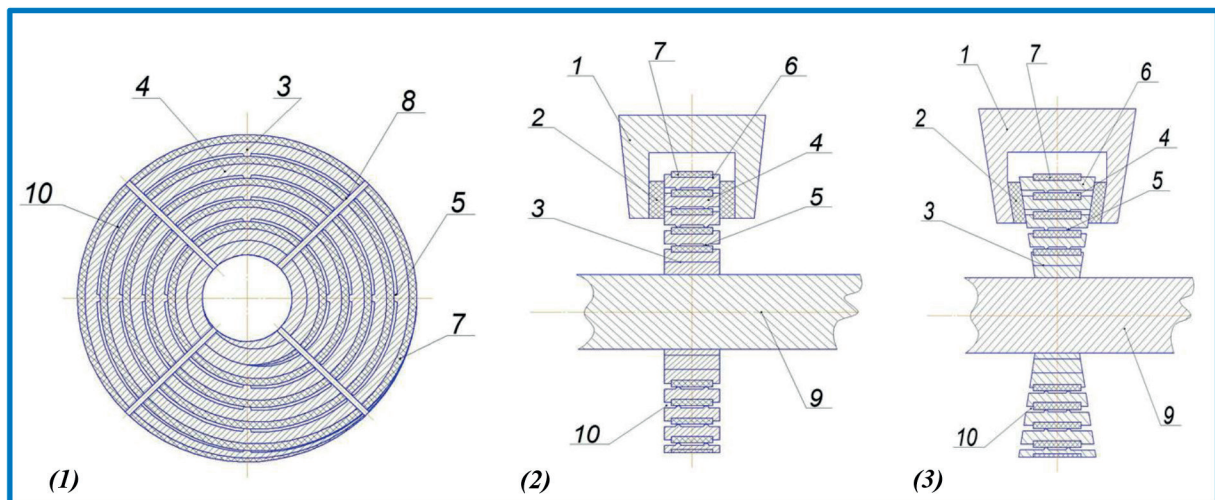

Fig. 3 Innovative design of rolling stock brake elements:

1 - longitudinal section view of the brake disc; 2 - cross section view of the disc brake with constant bands width; 3 - cross section view of the disc brake, bands width varying from disc center to the periphery

grooves for placing the strips of the inner heat removing plate on the inner side. Ventilation channels for cooling are formed between the strips of the outer contact plate. Strips can have a constant width or their width can wider from the disc center to its periphery, which enables to make use of greater amount of air in the ventilation channels.

A strip of the inner heat sink insert 7 is made of material with higher conductivity than the external strip material of the contact plate 4.

A strip of the outer contact plate 4 must be made of steel with high resistance to wear caused by friction material of the brake lining.

Before winding the strips of the outer contact plate 4 into the grooves 6, the inner heat conducting strip insert 7 is attached to the contact plate strips. The inner strip thickness 7 is greater than the depth of the groove 6, and its width is less than the one of the outer strip 4. This ensures the formation of ventilation channels 10 in the disc across its friction surface. The edges of the outer contact plate strip 4 are rounded to reduce wear of the friction pair "brake disc 3 - friction pad 2". Both strips are provided with holes 8 for attachment to the wheelset axis 9.

The mounting of the brake disc 3 is done by winding strips on the wheelset axis 9. Then the brake disc 3 is fixed on the wheelset axis 9. To ensure the acceptable level of the brake disc 3 imbalances, the run-out value must not exceed the set limit. The diameter of brake disc 3, the thickness of both strips and the width of air channels depend on material properties, rolling stock type, operating conditions, and maximum permissible speed of train.

During braking, the brake shoes 1 are pressed to the brake disc 3. The heat removal from the friction zone is due to:

1. Different heat conductivity of a bimetallic couple of the external strip of the contact plate 4 and the inner heat sink strip insert 7 which causes heat flow gradient in these sections of the brake disc 3. The inner heat sink strip insert 7 provides a more rapid transfer of heat through its cross-section than the outer strip of contact plate 4. As a result, on the border "strip of the outer contact plate 4 - internal heat sink inserts 7" there is a temperature difference. Less heated surface of the inner heat sink strip insert 7 serves as a refrigerator for the corresponding surface of the strip to the outer contact plate 4, accelerating the outflow of heat from its scope and, consequently, of the friction zone.

2. Convective transfer of heat formed on the surface of the strips through the vent channels 10.

Lowering the temperature of friction surface heating allows maintaining the friction coefficient output values for a long time and, therefore, braking efficiency. However, the decrease in temperature contributes to the preservation of the mechanical

properties of the contact surface layer, thereby increasing its resistance to wear.

The acceleration of heat outflow from the zone of inhibition leads to a decrease in the temperature of the heating strip of external contact plate 4 of the brake disc 3 in 1.5 - 2.0 times depending on the size and material of the insert strip 7. The result is improved braking efficiency and reduced wear of the contact surface.

The use of the wound design of the brake disc allows reducing the probability of cracks in the depth of the disc, thus increasing the reliability of its operation.

The proposed design use will provide additional cooling surfaces of the brake disc to reduce the friction surface wear, improve resistance to crack propagation in the depth of the disc, simplify the technological process of the brake disc replacement, due to the fact that it is not necessary to dismantle the wheels.

6. Conclusion

An effective braking system is an important part of safety and resource saving in rolling stock operation. The article considers braking elements interaction problem. Basic and advanced methods for the temperature stabilization of the brake element friction contact are presented. Based on the analysis we can conclude that the most widely used way of temperature stabilization is the implementation of a disc with ventilation channels. The design of discs with ventilation channels improves braking effect but, at the same time, it increases the vehicle running resistances. The study of vent disc movement resistance effect on different formulations showed that depending on the disc structure, their quantity and train speed, reduction of power ranges from 1% to 23%. In conclusion, disc elements with a shape memory design are proposed; they allow opening and closing the vents depending on the disc temperature and thereby eliminate the phenomenon of self-ventilation. The proposed innovative brake disc design takes into account the advantages of existing structures.

Acknowledgements

The research was conducted at the Department of Transport and Handling Machines of the Faculty of Mechanical Engineering of the University of Zilina by the National Scholarship Programme of the Slovak Republic for the Support of Mobility of Students, PhD Students, University Teachers, Researchers and Artists. The topic of the research is "Improving the safety and energy efficiency of rolling stock due to improvements in the brakes system".

References

- [1] TURKOV, A. I.: Research, Choice of Parameters and Development of the Basis for Designing a Friction Pair of a Disc Brake of a Railway Rolling Stock, Dr Science Thesis, Khabarovsk, 1982, 349 p. (in Russian)
- [2] GORBUNOV, N., KRAVCHENKO, E., DEMIN, R., NOGENKO, O., PROSVIROVA, O.: Analysis of the Constructive Features of Railway Brakes and Methods of Improving the Process of their Functioning, TEKA Commission of Motorization and Power Industry in Agriculture, vol. 13, No. 5, 2013, 98-102
- [3] GERLICI, J., LACK, T., ONDROVA, Z.: Evaluation of Comfort for Passengers of Railway Vehicles, *Communications - Scientific Letters of the University of Zilina*, vol. 4, 2007, 44-49, ISSN 1335-4205, EDIS: University of Zilina.
- [4] LACK, T., GERLICI, J.: Analysis of Vehicles Dynamic Properties from the Point of View of Passenger Comfort, *Communications - Scientific Letters of the University of Zilina*, vol. 3, 2008, 10-18, ISSN 1335-4205, EDIS: University of Zilina.
- [5] MYAMLIN, S., DAILYDKA, S., NEDUZHA, L.: *Mathematical Modeling of a Cargo Locomotive*, Proc. of the 16th Intern. Conference "Transport Means". Kaunas, 2012, 310-312.
- [6] GERLICI, J., LACK, T., HARUSINEC, J.: Rail Vehicles Wheels and Brake Blocks Wear Laboratory Test Stand Utilization. *Prace Naukowe. Transport: Analiza i ocena elementow systemow transportowych*, 101, 2014, 21-32.
- [7] GERLICI, J., LACK, T., HARUSINEC, J.: Realistic Simulation of Railway Operation on the RAILBCOT Test Stand. *Applied Mechanics and Materials*, 486, 2014, 387-395.
- [8] GERLICI, J., GORGUNOV, M., KRAVCHENKO, K., KOSTYUKEVICH, A., NOZHENKO, O., LACK, T.: Experimental Rigs for Wheel/Rail Contact Research. *Manufacturing Technology*, 2016, vol. 16, No. 5, 909-916.
- [9] GERLICI, J., LACK, T.: Rail Geometry Analysis (from the Point of View of Wearing in the Operation), *Communications - Scientific Letters of the University of Zilina*, vol. 1, 2003, 43-51, EDIS UNIZA Zilina 2003.
- [10] DAMDYN, S. I.: *Increasing the Energy Consumption of Wheel Brakes by Introducing an Inverse Pair of Friction with Liquid-Cooled Discs* (in Russian), PhD Thesis, Moscow, 1994, 23 p.
- [11] SIMAGAEVA, Z. D.: *Patent RF*, No. 2454576, Disc Brake Pads Car, kl. F16D65/092, F16D65/847, F16D69/00, publ. 27.06.2012 (in Russian).
- [12] KRYLOV, V. I., KRYLOV, V. V.: *Automatic Brakes of Rolling Stock. Textbook for Students of Technical Schools of Railway Transport* (in Russian), Moscow, 1983, 360 p.
- [13] IGNATIEV, D. M., LUGOVAYA, N. G., LEVIT, M. Z., KASATKIN, G. P., TRAVIN V. L., PIVEN, E. G., SMIRNOV, D. D., FRANTOVA, E. YU., PEREVOZCHIKOV, N. K.: *Patent RF*, No. 2115044, Brake Pad Rolling Stock, kl. F16D69/02, B61H7/02, publ. 10.07.1998 (in Russian).
- [14] GORBUNOV, M., MOGILA, V., KRAVCHENKO, K., PROSVIROVA, O., SKORNJAKOV, S.: *Patent for Utility*, Model No. 70861, Brake disc, kl. F16D 65, publ. 25.06.2012, bul. No. 12 (in Ukrainian).
- [15] GORBUNOV, M., GERLICI, J., LACK, T., HAUSER, V., LOULOVA, M., HARUSINEC, J., KRAVCHENKO, K., NOZGENKO, O., PROSVIROVA, O., KRAVCHENKO, K.: *Application for Invention*, No. a/2017 01575 from 20.02.2017, Disc brakes (in Ukrainian).
- [16] TOMSKY, K. O.: *Increasing the Efficiency and Wear Resistance of Braking Devices by Using Bimetallic Materials* (in Russian), PhD Thesis, Moscow, 2013, 24 p.
- [17] ISAEV, I.: *Patent RF*, No. 2216664, Brake element, kl. F16D69/02, F16D65/02, Publ. 20.11.2003 (in Russian).
- [18] VOLKOV, V. P., DYUKAREV, N. V., VOLKOV, YU. V.: A Retrospective Analysis of the Development of the Design of Brake Mechanisms for Cars. *Vestnik KhNAHU*, No. 41, 2008. <http://cyberleninka.ru/article/n/retrospektivnyy-analiz-razvitiya-konstruktsii-tormoznyh-mehanizmov-legkovykh-avtomobiley> (in Russian).