

Jan Latal - Miroslav Kralik - Zdenek Wilcek - Jakub Kolar - Josef Vojtech*

DEPLOYMENT AND MEASUREMENT OF QUALITY OF SERVICE PARAMETERS FOR TRIPLE PLAY SERVICES IN OPTICAL ACCESS NETWORKS

Broadband telecommunication networks are the future of communication and distribution of multimedia services. Thanks to the high transmission potential and capacity of optical fibres, the optical networks are predestined to be more widely used in telecommunications considering the higher data rates through Triple Play services. This paper describes the impact of selected quality parameters on multimedia services defined as Triple Play within an optical network based on the EPON standard. The Triple Play services are then evaluated with measuring instruments and software applications according to QoS requirements and using evaluation methods based on generally defined standards. These are mainly subjective (listening and conversational) and objective (MSE, PSNR, SSIM) methods, or parameters (MOS) and factors (bitrate, delay, packet loss rate, jitter, BER) that are defined for the respective service. The values measured during the experimental tests were related to the limiting parameters of optical topology based on EPON networks for individual services according to their QoS requirements and objective user evaluation.

Keywords: Triple play, QoS, EPON, MSE, PSNR, SSIM, MOS, MPEG.

1. Introduction

By using the broadband optical networks, telecom operators were allowed to distribute new types of multimedia services. To make it happen, however, it was necessary to find a suitable type of telecommunication system that would provide high transfer rates and allow reconfiguration. Nowadays, the role of this system is primarily played by optical networks. It was necessary to define the termination of the optical connection at the end customer according to FTTx (Fiber To The x), where x defines the termination of the optical line. FTTx networks are interconnected with PON (Passive Optical Network) optical access networks, which can be classified by their type into several kinds of EPON (Ethernet PON), GPON (Gigabit PON) or 10 GEPON (10 Gigabit EPON). They are going to gradually replace other technologies of access networks (e.g. xDSL-x Digital Subscriber Line, WiFi, etc.) and will probably very soon become the dominant access technology for access networks of the next generation - NGA (Next Generation Access). However, instead of using TDM (Time Division Multiplex) communication, the development of optical networks seems to

head towards WDM (Wavelength Division Multiplexing), which brings new possibilities for increasing transmission capabilities and sharing multiple wavelengths between several end customers. There has also been a change of access to the media, as in passive optical networks, the TDMA (Time Division Multiple Access) time sharing approach is now being used more often, and new hybrid optical networks known as WDM-TDMA PON (Wavelength Division Multiplexing-Time Division Multiple Access Passive Optical Network) emerge with data rates of tens of Gbps. Moreover, the termination by FTTx enables to connect either directly to the home (FTTH, Fiber To The Home option) or to the office for corporate or office spaces (FTTO, Fiber To The Office option), but there is also the possibility of combined optical-copper connections using the current copper wiring in buildings, objects or larger blocks. These are the most often the FTTB (Fiber To The Building), FTTC (Fiber To The Curb) or FTTN (Fiber To The Node) variants. However, the main idea of the proposed solution of terminating all FTTx optical connections is the same. It is based on our intention to provide sufficient data rates for network endpoints and thus enable the end subscribers to access modern multimedia services. The one thing that the

* ¹Jan Latal, ¹Miroslav Kralik, ¹Zdenek Wilcek, ¹Jakub Kolar, ²Josef Vojtech

¹VSB-Technical University of Ostrava, Faculty of Electrical Engineering and Computer Science, Department of Telecommunications, 17. listopadu 15, Ostrava-Poruba, 70800, Czech Republic

²CESNET, a. i. e., Zikova 1903/4, 160 00 Prague 6 Czech Republic

E-mail: jan.latal@vsb.cz

aforementioned possibilities of using up-to-date services have in common is that we need a very careful and comprehensive design and planning of such network topology or infrastructure. It is necessary to pay attention to the fact that the given topology will be assembled not only from optical, but also metallic or wireless systems that must cooperate with each other. As a result, this can lead to lowered costs of both OPEX (Operating Expense) and CAPEX (Capital Expenditures) [1, 2].

By cooperation we mean the mutual synergy and adjustment, the management and reconfiguration options, and last but not least the available effective bandwidth for data transmission. Taking into account the different demands of the stated essential services within the “Triple Play” offer, it is also necessary to guarantee their QoS (Quality of Service) by establishing the necessary mechanisms for reserving sufficient transmission resources. For multimedia and voice services it will be necessary to solve the issues of delays in signal propagation, its fluctuations, etc. in a satisfactory manner [3 - 5].

The object of the following paper is to focus on Triple Play services and their requirements with regard to the parameters that have the largest impact on them, such as packet loss rate, delay, jitter and bandwidth, and also to demonstrate how these services behave in an experimental optical network [2, 3, 5]. All of these parameters are then related to the limiting values of the ODN (Optical Distribution Network), which is modified using fibres according to the ITU-T G.652 D standard and has a digital variable attenuator that can simulate longer and lossy transmission lines.

2. State of the art

Nowadays, the ever-growing demand for multimedia services and their development will, beside other things, require a thorough analysis to enable their smooth deployment and transmission, either within the existing or newly built networks. Optical networks serve as an example of a stable and high-quality system that represents the future for distribution of data communication. However, the deployment of multimedia services lies not only in using EPON, WDM-PON (Wavelength Division Multiplexing Passive Optical Network) or NGA/NGN (Next Generation Access/Next Generation Network) technologies, but also in GPON networks. GPON is a standard in compliance with ITU-T G.984 and is based on the use of GEM (GPON Encapsulation method) protocol with ATM (Asynchronous Transfer Mode) cell support, while EPON (IEEE 802.3 ah) is based on the IP protocol. The GPON technology is very often deployed in Asian and American countries, where it is used for broadband access networks. GPON allows adjusting SBA (Static Bandwidth Allocation) or DBA (Dynamic Bandwidth Allocation), which is also used in EPON networks. However, neither of these networks

defines the maximum possible parameters when achieving QoS for end units/users through Triple Play services [1, 2, 4, 6].

The research team of authors [7] has pursued the idea of improving the dynamic bandwidth allocation among differentiated services while maintaining QoS parameters defined for Triple Play in EPON networks through FIPACT (Frame-Oriented Interleaved Polling with Adaptive Cycle Time) algorithm [8]. To optimize the use of FQ-DBA (Frame-based QoS provisioning Dynamic Bandwidth Allocation) for allocating multimedia streams, a combination of EPON and WDM-PON is used while maintaining QoS parameters. Data streams for terminal units are preferentially defined using FQ-DBA in order to achieve sufficient bandwidth for a given service with respect to QoS.

In another paper, the team of authors discussed the possibilities of faster channel switching in EPON networks for IPTV (Internet Protocol Television) service using a new algorithm [9].

The IPTV and the use of IGMP (Internet Group Management Protocol) protocol in NGN will gain more importance. However, there are also associated problems with QoS and multicast distribution guarantees. The EPON networks meet the stringent demands on higher bandwidth and QoS, but they do not have satisfactory algorithms for allocating channels or streams among individual terminal units. For IPTV, the multicast mode needs a unique LLID (Logical Link Identifier) per channel for each ONU (Optical Network Unit) terminal unit. To prevent congestions of the network and OLT (Optical Line Termination) unit, a new type of algorithm for assigning LLID for individual IPTV channels has been designed [10].

Video quality analysis was researched in the study, comparing video codecs with relation to packet losses in the network. The results of them were artefacts in the video [11]. In other publications, however, the authors have focused on the impact of multiplying variable bitrate HD (High Definition) video streams with variable QoS settings. They have produced numerical simulations for various settings of packet loss, delay, jitter, bandwidth, etc. SwissQual VQuadHD and Telchemy VQMon applications were used for the evaluation [12].

Several research teams have also decided to simulate the behaviour of an EPON network with the Triple Play services implemented. They created an EPON network topology with a variable number of ONU terminal units and ODN network length of 0–65 km in a simulation environment. The results of the simulations confirm that the error rate changes with increasing number of terminal units, which affects the overall error rate of the given topology [13]. Apart from studying the ODN network range, other teams have also focused on the Q-factor, differential settings of system transfer rates from 2.5 to 10 Gbps with a variable number of terminal units connected in a network of 60–130. Based on simulations, it has been found that the EPON network can distribute sufficient transmission capacities even at 10 Gbps at a distance of up to 40 km [14].

3. Triple play

The term Triple Play service is well known nowadays, primarily when referring to multimedia services provided to ordinary customers. Triple Play is a term for a package of three services: high-speed data, internet television (IPTV) and internet telephony (VoIP, Voice over Internet Protocol) provided to the end user over a single connection. All of these services are distributed using the IP protocol (ISO/OSI model layer 3) in Ethernet network (ISO/OSI layer 2). The services are differentiated by the transport layer (ISO/OSI model layer 4). For transferring the data service, the TCP (Transmission Control Protocol) is used, which provides a reliable connection-oriented data transfer. In case of a data loss, a request to retransmit the lost data is sent. VoIP and IPTV multimedia services use the UDP (User Datagram Protocol), which provides connectionless and unreliable type of data distribution. In case of a data loss, there is no retransmission of the lost data. This approach eliminates delays, but degrades the service. Apart from the delay, other important parameters that affect the quality of multimedia services are also the bandwidth, packet loss rate and jitter (delay fluctuations) [15]. Another parameter that also has an impact on the distribution of Triple Play services is OoS (Out of Sequence), which indicates wrong order of data reception, i.e. when the data is received in an order that is different from the order in which it was originally sent. This phenomenon can occur when the data travels through different paths in the network. The QoS (Quality of Service) term is defined with the multimedia services and describes the technical part that must be maintained for the right functionality of the individual services. Based on the requirements, the services can be classified with regard to the transmission type [2]. Therefore, the distribution of Triple Play services has much higher demands on the quality of the distribution infrastructure when compared to the conventional data transfers. The applied technology must provide enough capacity to support the QoS mechanisms (CoS/DiffServ, etc.) that will allow the distribution of services with different requirements for bandwidth, sufficient level of QoE (Quality of Experience), security and reliability.

3.1 Factors affecting the quality of audio and video services

There are numerous of factors that affect multimedia services and have a negative effect, causing gradual deterioration in the quality of the individual audio and video services. Applications used for voice, video and data transmission need more bandwidth for the transfer and they are sensitive to delay and packet loss. As soon as these parameters are exceeded, the service becomes unusable. During the transmission of data, there can be several possible causes of problems on the way from the sender to the

recipient. We talk about latency, packet order, delay, bitrate, delay fluctuation (jitter) and packet loss [2].

3.2 Methods for determining the quality of VoIP service

The methods for evaluating speech quality can be classified into two basic groups: the subjective and the objective evaluation methods. During our measurements we were focused on subjective as well as on objective methods for evaluating the quality of VoIP. They will be mentioned and described in the following chapters.

3.2.1 Subjective VoIP service quality evaluation

The conversational methods (CQ - Conversational Quality) are laboratory simulations where two subjects communicate via a phone call and evaluate the transmission quality of the call signal. A third person measures the test conditions. The evaluation uses the MOS (Mean Opinion Score) rating scale. The listening methods (LQ - Listening Quality) do not reflect reality as much as the previous type, but they are easier. They consist of playing speech signals to the subject who evaluates them using multiple possible methods (ACR - Absolute Category Rating, QRDM - QR-decomposition with M-algorithm, DCR - Degradation Category Rating, CCR - Comparison Category Rating). The MOS rating parameter was created based on the ITU P.800 recommendation. It is a part of ACR family - the Absolute Category Rating, based on the comparison of a received signal with the reference signal. The result is obtained by averaging the subjective user opinions about the perceived voice [2].

3.2.2 Objective VoIP service quality evaluation

Here, the statistical evaluation of mathematical models that simulate the human auditory system is used. Among the best algorithms are PAQM (Perceptual Audio Quality Measure), PSQM (Perceptual Speech Quality Measure), NMR (Noise-to-Masked-Ration, PERCEVAL (Perceptual Evaluation), DIX (Disturbance Index), OASE (Objective Audio Signal Evaluation) and POM (Perceptual Objective Measure). We can also mention a metric one which, apart from factors affecting quality, also takes user perception into account. This metric is called R-factor and is used in a calculation model known as the E-model. This model is described in detail in the recommendation G.107. The basic formula for calculating the value of R-factor is [16]:

$$R = R_0 - I_s - I_d - I_e + A \quad (1)$$

where R_0 is the basic signal-to-noise ratio, I_s is the simultaneous interference factor defined as the sum of all deterioration

effects (noise from the surroundings, etc.) which can occur simultaneously with voice transmission, I_d represents all deteriorations caused by the delay of voice propagation, I_e (also labelled as I_{E-EFF} in the literature) is a factor representing the degradation of quality caused by the packet loss, and A is an advantage factor that depends on the concentration of the listener (from 0 to 20 depending on the codec) [2]. The above mentioned calculation also includes a set of recommended values which allows to simplify the calculations to suit the packet networks. Among the important parameters with regard to QoS in packet-based networks are the network delay, jitter and packet loss. These parameters are included in two of the parameters mentioned in the R-factors calculations, namely in I_d and I_e (or I_{E-EFF}) [3, 5].

$$I_d = I_{DTE} + I_{DD} \quad (2)$$

The I_{DTE} parameter represents the factor of impairment caused by echo (echo cancellation has been solved in ITU-T G.168 recommendation). The I_{DD} factor represents the factor of interference caused by a too long transmission delay. By keeping all the default values in R-factor calculation we obtain the final value of 93.35. The value of 93.35 can be achieved only in ideal environment without any disturbance. In order to meet the user expectations, it is necessary to get a value of 70 or more. A simplified R-factor calculation uses this final form:

$$R = 93.35 - I_d - I_e \quad (3)$$

The resulting R-factor is a numerical value that usually lies between 15-94, while the value above 70 is considered to be acceptable.

3.3 Methods for determining the quality of IPTV

There are recommendations for evaluating image and video signal quality available, e.g. ITU-T P.910. Subjective measurements of image and video signal quality are based on the human perception. The advantage of this measurement is that people can describe the image according to what they really see and therefore suppress information that is imperceptible to the human eye. The subjective measurements are influenced by a number of factors which makes the repeatability of these subjective measurements difficult. There are several approaches to IPTV quality measurements, for instance MSE, PSNR, SSIM, MDI (Media Delivery Index) or MPQM (Moving Pictures Quality Metric) to name some of the objective methods. The group of subjective methods for evaluation of IPTV quality include MOS, DSCQS (Double Stimulus Continuous Quality Scale), DSIS (Double Stimulus Impairment Scale), and ACR (Absolute Category Rating). Within experimental measurements we were primarily focused on the objective methods of IPTV quality

evaluation, namely on the MSE, PSNR and SSIM described in more detail below, and supplemented them with real measured values in later chapters [2, 17, 18].

3.3.1 MSE (Mean Square Error)

MSE represents the mean square error between the received and original video signals. The following formula is used for the calculation:

$$MSE = \frac{1}{M \times N} \sum_{j=0}^{M-1} \sum_{i=0}^{N-1} (x_{ij} - y_{ij})^2 \quad [-] \quad (4)$$

where x is the original image, y is the received image, elements i and j are the elements of the image matrix, M is the image height in pixels and N is the image width in pixels [2].

3.3.2 PSNR (Peak Signal to Noise Ratio)

PSNR is the ratio between the highest values relative to the MSE and is expressed by the following formula:

$$PSNR = 10 \times \log \frac{m^2}{MSE} = 20 \times \log_{10}(m) - 10 \times \log_{10}(MSE) \quad [dB] \quad (5)$$

where m is the maximum value a pixel can get [2].

3.3.3 SSIM (Structural Similarity Index)

The SSIM parameter takes the human visual system into account. It measures the similarity between two images. The SSIM has been developed to improve conventional metrics such as MSE and PSNR that were proven to be inconsistent with human perception. The reference values lie within the interval of $\langle 0,1 \rangle$, where 0 represents no relationship to the original image and the value of 1 is reached when two identical pictures are compared.

$$SSIM(x, y) = [l(x, y)]^\alpha [c(x, y)]^\beta [s(x, y)]^\gamma \quad (6)$$

The term $l(x, y)$ is used to compare the signal luminance, the term $c(x, y)$ compares the signal contrast and the term $s(x, y)$ is used to measure the structural correlation, which is calculated from the following relations:

$$l(x, y) = \frac{2\mu_x\mu_y + c_1}{\mu_x^2 + \mu_y^2 + c_1} \quad (7)$$

$$l(x,y) = \frac{2\sigma_x\sigma_y + c_2}{\sigma_x^2 + \sigma_y^2 + c_2} \quad (8)$$

$$l(x,y) = \frac{\sigma_{xy} + c_3}{\sigma_x\sigma_y + c_3} \quad (9)$$

where μ_x and μ_y represent the average of x and y samples, C_1 , C_2 are constant and σ_x and σ_y represent the dispersion of x and y samples [2].

4. Carrying out experimental measurements of triple play services in EPON network

Here we come to the real results that were obtained in the course of measuring the effects of ODN limiting parameters on the built optical topology for different types of Triple Play services. However, the main motive is to demonstrate and verify the practical impact of the main network parameters on the behaviour of multimedia as well as traditional data services. This chapter gives an overview of the impact of QoS parameters on Triple Play services within the EPON network (EPON type 2). The introduction provides a description of the used experimental topology and devices designed to simulate Triple Play services in a network, and then a set of tests and their results. The processed measured values are a subject to evaluation through objective tests based on mathematical foundations described above.

4.1 Measurement of triple play services in EPON network

The basis for the measurement was the topology shown in Figure 1, using a core of OLT EPON type 2 unit with the following basic parameters: the range of about 20km, the maximum defined split ratio of 1:32 at the used wavelengths 1310 nm (upstream), 1490 nm (downstream) and a transmission rate of 1 Gbps or 1.25 Gbps, where 250 Mbps is used for overhead needed for data transmission and administration [1]. Among other parts was an optical line with the length of 5.773 km made of an ITU-T G.652 D fibre and six ONT/ONU terminal units connected through a symmetric optical splitter (1:7 ratio) having an insertion loss of 8 dB. Additionally, the tested topology was supplemented by EXFO FVA-60B device that was supposed to simulate the ODN network range by increasing insertion loss into the line. The topology was also supplemented by a Simena NE1000 network element for impairment creation, Abacus server used as an IPTV server, a PC (Acer laptop) with MSU Video Quality Measurement Tool application, IP phones (Grandstream GXV3140) to create VoIP service and finally a EXFO AXS200/625 measuring instrument to evaluate qualitative parameters of the multimedia services.

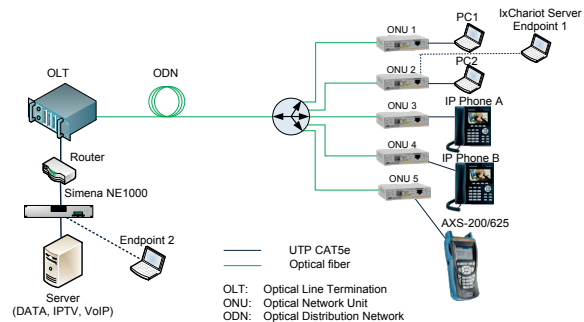

Fig. 1 The topology for Triple Play services deployment and for monitoring the impact of QoS parameters on the services

The Triple Play services were enabled by an Abacus server on which the individual services were implemented, and the user side used laptops or IP phones. The tested topology was also supplemented by a PC with the IxChariot tool (and also serving as an Endpoint 1 for this tool) and by another PC which worked as an Endpoint 2. This topology extension marked with a dashed line in the diagram enabled us to define the quality of VoIP services and to evaluate it. As our goal was to determine the limiting values of the optical distribution network (ODN) and its impact on the Triple Play multimedia services, we have defined the values at which the given topology was still fully functional without communication breakdowns or increased error rates. During the experimental measuring it has been proven that with an additional insertion loss in the line created by a variable digital attenuator, the given topology was able to bridge a gap of 21.95 dB at the wavelength of 1310 nm. It should be noted that the value is related primarily to the ONU unit, as the OLT unit was still able to transmit with 32.2 dB insertion loss at the wavelength of 1490 nm. However, this is caused by the fact that the transmitter located in the OLT unit has more power than the source of radiation used in the ONU unit.

For our purposes, the service for VoIP was distributed via IxChariot. The codecs used were G.711 μ -law, G.723.1 ACELP (Algebraic Code-Excited Linear Prediction), G.729. These types of codecs are often used for VoIP communications and compression of audio data. The most bandwidth/bitrate-demanding codec is G.711 μ -law, which requires 64 kbps. The G.711 standard was designed in 1992 and is intended for PSTN networks. G.723.1 - this standard is intended for multimedia applications and includes two speech coders. One of them uses a transmission rate of 5.3 kbps and the other one a transmission rate of 6.4 kbps. The distinctions between them are in different codebooks with different excitation sequences. The frame size is 30 ms, the delay due to frame overlapping is 7.5 ms, and the total delay of the coder is 67.5 ms. The G.729 standard has been developed primarily for mobile networks applications. A coder based on G.729 has a low bit rate of 8 kbps. The frame size was set to be 10 ms, which allowed reaching a compromise between the

quality of the reconstructed speech signal and the computational complexity of the coding algorithm. The delay caused by frame overlapping (lookahead) is 5 ms and the total delay is 25 ms. Nowadays, however, we can find more advanced types of codecs [2, 16].

The distribution of video streams was prepared using VLC Streamer and Abacus server with three main HDTV (High-definition television) and SDTV (Standard-definition television) video samples and different types of MPEG-2 (Moving Picture Experts Group) or MPEG-4 compliant compression codecs. MPEG-2 is the older of the codecs and was developed in 1994. Its predecessor is the MPEG-1 format and its more advanced technological successor is the MPEG-4 format. MPEG-2 is the standard format used for storing and transferring video on DVDs or for the distribution of DVB-T (Digital Video Broadcasting - Terrestrial) digital television signal. Applications that require real-time MPEG-2 video compression and decompression are much more demanding in terms of the computing capacity of a processor than with the MPEG-1 format. The difference between MPEG-1 and MPEG-2 formats is that the latter can work with the so-called VBR (Variable Bit Rate). MPEG-2 was developed for the resolution of 720×576 pixels which corresponds to SDTV. MPEG-4 is a collection of patented methods that define the compression and storage of audio and video data. It was introduced to the world in 1998 and it represented a group of standards for encoding audio, video and related technologies.

It was formally issued by ISO/IEC MPEG as an ISO/IEC 14496 standard. Many features of the MPEG-4 standard are defined as optional. MPEG-4 is a standard which is still being developed, especially some of its parts. The new compression method according to H.264 for MPEG-4 version 10 will also come in handy to those who need to effectively archive or download/upload video recordings. The H.264 codecs allow reducing the capacity demands for the transmission of video data streams to one half or one third when compared to MPEG-2, which makes them an ideal type of codec for any kind of broadcast. The following chapters state all measurement methodologies for Triple Play services in EPON networks [2, 17, 18].

4.2 Measuring IPTV using EXFO AXS 200/625

The first step of the experiment with the Triple Play services implemented in the EPON network was measuring the data rates of three different video samples. These samples were distributed via a network established from a server to a terminal unit represented by EXFO AXS 200/625 analyser. The analyser performed detailed measurements of the impact of the loss rate in the selected video samples on the limit value of the experimental topology with EPON. In Table 1 we can see the test samples used for measuring the change of transmission rate and the impact of

Samples used for transmitting in the analysis with AXS 200/650

Table 1

Samples	File type	Size [MB]	Average bitrate [kbps]	Frames per second	Resolution	Codec	Length
MPEG-2 HDTV	MPEG	374	9 843	29.970	1 280×720	MPEG2	5 min 9 s
MPEG-4 HDTV	AVI	420	11 456	29.970	1 920×1 080	MPEG4	5 min 7 s
MPEG-2 SDTV	MPEG	136	1 154	25.000	720×480	MPEG2	14 min 46 s

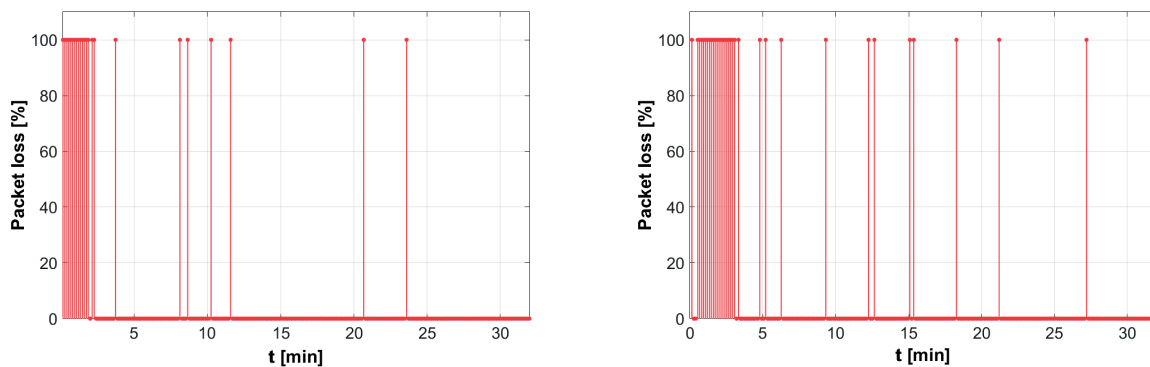

Fig. 2 MPEG-2 HD (left) and MPEG-4 HD (right) video

transmission time on the error rate (packet loss) for the limiting settings of the experimental topology with EPON.

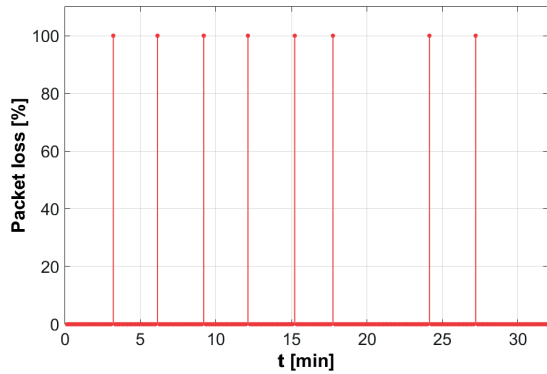

Fig. 3 MPEG-2 SD video

Figures 2 and 3 present the effect of the transfer rate on the error rate, i.e. packet loss. The length of the measurement was 30 minutes (to be more specific, although the test samples are shorter than the test period, they were played in a loop) and the network throughput was changed from 10 Mbps to 100 Mbps in steps of 10 Mbps every 3 minutes. The EXFO AXS 200/625 analyser evaluated the error rate using a 1/0 method, where “1” means there was an error and “0” means there was no error. We can see that the transfer rate influenced the error rate primarily in the HD video samples. The occurrence of errors depended on the video *bitrate* and the large occurrence of errors took place only during the first step (the first 3 minutes) at a speed of 10 Mbps, which confirms the demand for a minimum data rate defined for a particular video format in QoS [2]. In the subsequent steps, the errors in the HD video samples occurred just rarely. For the MPEG-2 SD sample, the errors occurred rarely from the beginning to the end of the experimental measurement.

4.3 MSU video quality measurement tool - IPTV service

For the next step of testing the IPTV services, the MSU VQMT software application was used to evaluate and analyse the objective methods. Using a Simena NE1000 network emulator we modified the critical parameters of the network that in turn

affected the IPTV. Three basic types of video samples (see Table 2) were used for experimental measuring, which are the types currently used for distributing IPTV to its customers.

The effect of bitrate on the objective methods MSE, PSNR and SSIM can be seen in Figs. 4-6. Figure 4 shows the plot of the MSE objective method that represents the mean square error between the original signal and the signal received on the other side of the network. Deterioration can be seen in MPEG-2 HD and HD MPEG-4 video samples at speeds lower than 20 Mbps. It comes from their demand for bitrate which for the given video resolution varied up to a maximum of 20 Mbps and did not exceed this value. The MPEG-2 SD sample shows no errors, even when it requires a bitrate lower than 10 Mbps. The PSNR objective method is similar.

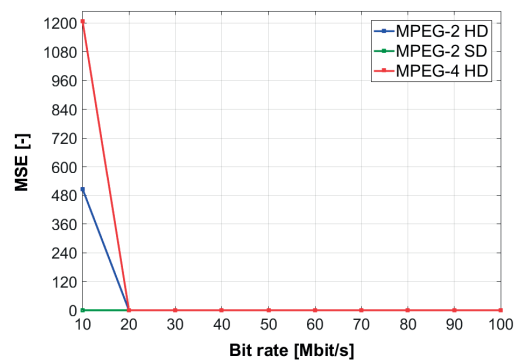

Fig.4 The effect of bitrate on MSE

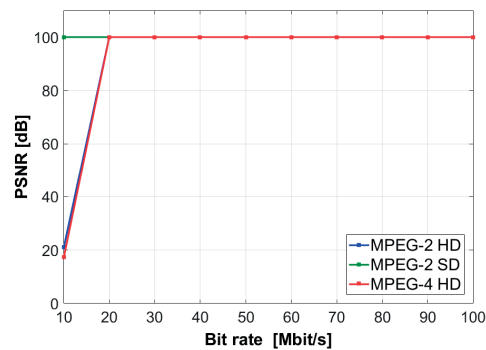

Fig. 5 The effect of bitrate on PSNR

Video samples used for analysis by the objective methods with the VQMT MSU application

Table 2

Sample	File type	Size [MB]	Average bitrate [kbps]	Frames per second	Resolution	Codec	Time
MPEG-2 HDTV	AVI	26.7	10 427	29.970	1 280×720	MPEG-2	20 s 19 ms
MPEG-4 HDTV	AVI	24	9 061	29.970	1 920×1 080	MPEG-4	20 s 89 ms
MPEG-2 SDTV	AVI	5.9	2 132	25.000	720×480	MPEG-2	20 s 88 ms

Figure 6 shows plots of the SSIM objective method, which is based on the MSE and PSNR methods. The results of the measurement are very similar. Slightly worse results were obtained for the MPEG-4 HD video sample when the bitrate was 10 Mbps.

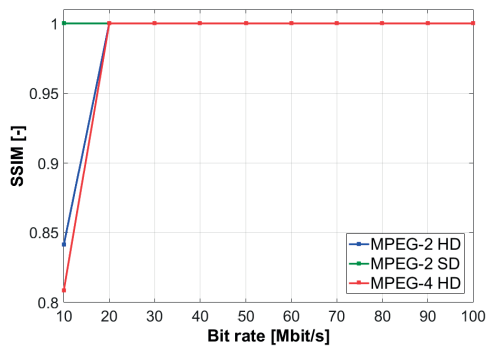

Fig. 6 The effect of bitrate on the SSIM

Figure 7 plots the effect of error rate on the MSE and PSNR objective methods. The worst results were obtained for the MPEG-4 HD sample and the results were very good for the less demanding video represented by MPEG-2 SD. The effect or change of the values for each of the objective method appears for BER = 10⁻⁸ or lower.

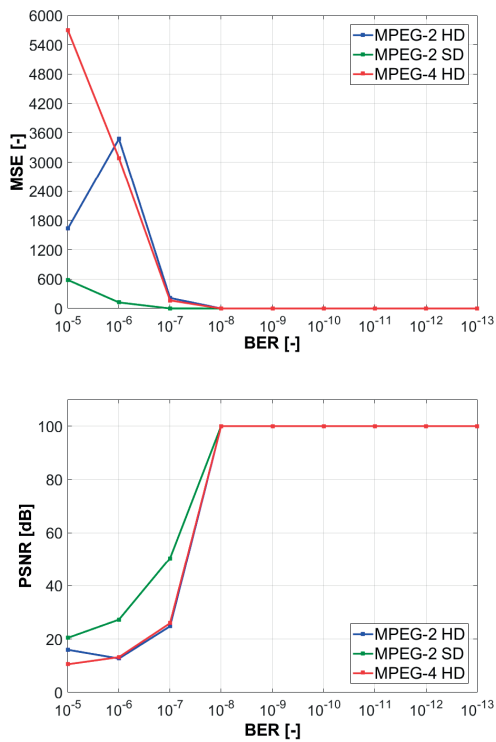

Fig. 7 The effect of BER on MSE (top) and PSNR (bottom)

Figure 8 shows the effect of the error rate on the SSIM objective method. The results are similar as for the previous

methods. Here again the MPEG-4 HD sample gives the worst values and the effect can be seen for BER values below 10⁻⁸.

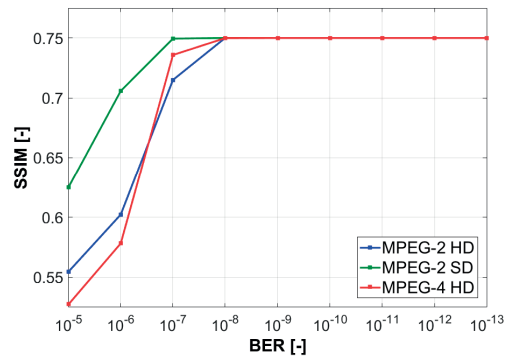

Fig. 8 The effect of BER on SSIM for the tested video samples

Figures 9 and 10 show the impact of packet loss rate on the objective methods MSE, PSNR and SSIM. For these parameters it is possible to see the effect starting from the smallest set values. We can also see relatively large fluctuations of the values, which may be caused by the set dynamic packet loss rates at the individual percentage values. The real measurements show that MPEG-4 HD has the worst results and by contrast, the best results can be seen for the MPEG-2 SD sample.

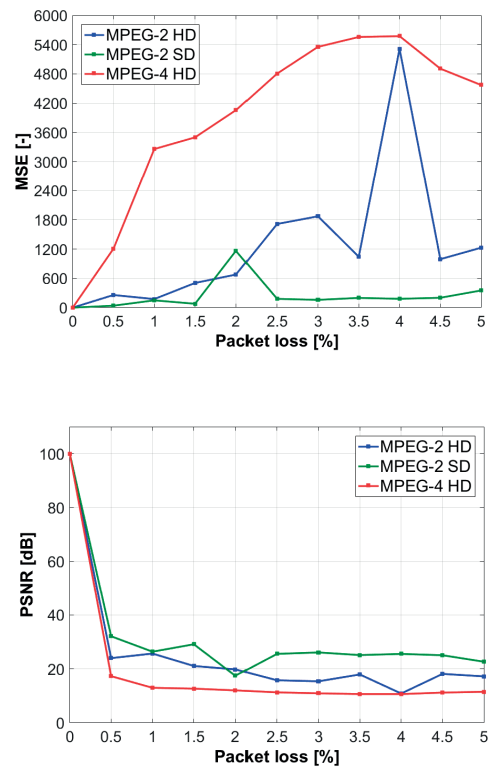

Fig. 9 Impact of packet loss rate on MSE (top) and PSNR (bottom)

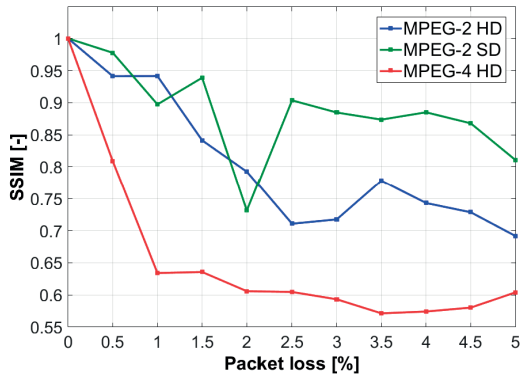

Fig. 10 Impact of packet loss rate on SSIM

By using the quoted results and our observations of the video samples we can evaluate the impact of the individual parameters on the video quality. For the BER (Bit Error Ratio) parameter, the quality is deteriorated for values of 10^{-7} . The packet loss rate parameter affects the video from the lowest set value, but the difference can be seen in MPEG-2 SD and MPEG-2 HD, where MPEG-2 HD with high loss rate (about 3%) is hard to watch, while MPEG-2 SD image is much better to distinguish and watch. The difference can also be seen for admissibility, which has an impact on the format and resolution of the video. The effects of QoS parameters such as *jitter* and delay was also observed. The requirements state the maximum value of *jitter* to be less than 50 ms and delay under 200 ms. During testing, these parameters were set at much higher values, yet there was no impact on the video quality. However, they did cause a delay of the received audio signal from the original transmitted one.

4.4 IxChariot - VoIP service

The evaluation of VoIP call quality has been carried out mainly on the G.711 μ -law codec, which is supposed to be the most often used codec by voice service providers. A comparison with other codecs (G.723.1 ACELP, G.729) has also been made. The main parameters by which the voice call was evaluated were MOS and R-factor values, which are related and can be compared with each other. To evaluate the VoIP service, we have used the IxChariot program that allows the simulation of calls with various settings. We have evaluated the effects of several critical parameters (bitrate, jitter, BER, delay and packet loss rate) that have the greatest impact on the quality of the service. The values obtained from the experimental measurements are shown in Figs. 11 - 13.

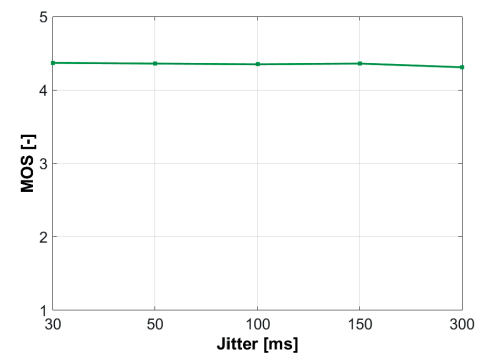
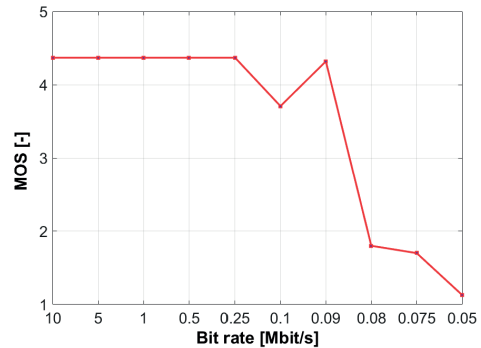

Fig. 11 The impact of the bitrate (top) and jitter-u (bottom) on the call quality (MOS) for VoIP codec G.711

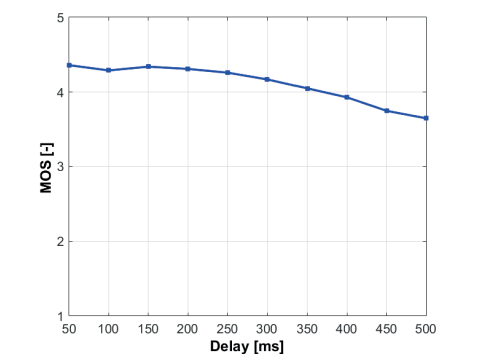
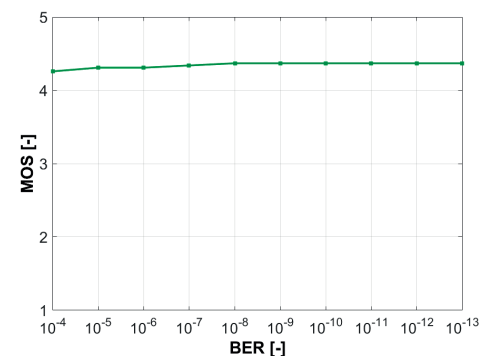

Fig. 12 The impact of the BER (up) and delay (down) on the call quality (MOS) for VoIP codec G.711

Figures 11 and 12 show the impact that the changes of individual parameters have on the call quality for codec G.711 μ -law. Parameters such as delay, jitter and error rate have almost no effect on the call quality, even when they are set above the values defined as maximum for QoS requirements in ITU-T. This was caused by the fact that the network load was low during the measurement as there were no running services for IPTV or data transmissions. The effect on the MOS value is apparent for the bitrate change (see Fig. 11) when the value was set to 0.09 Mbps or less. These are low bitrate values, but the given topology can cover them without major problems. The last parameter also has the largest impact – it is the packet loss rate. That is why this parameter was also tested on other types of codecs. Apart from G.711 μ -law these were G.729 and G.723.1 ACELP.

Figure 13 shows that the highest impact of packet loss rate can be seen with the G.711 μ -law codec, for which the MOS value dropped from 4.2 down to 1.73, which is already a value showing unsatisfactory to poor call quality, while the limiting value of MOS for a satisfactory call is 3 or above. For G.729 and G.723.1 ACELP codecs the MOS value turned out to be just under the limit of 3 (the G.723.1 ACELP codec), where these codecs reach the limits of acceptability for call quality at the packet loss rate of 5%. The codec that is most resistant against packet loss is G.729.

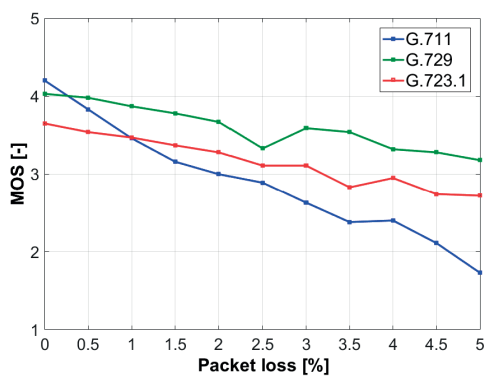

Fig. 13 The impact of packet loss rate on VoIP call quality (MOS) for individual codecs

4.5 The impact of QoS parameters – data service

The impact of QoS on the data transfer was recorded using the BWMeter software application. It allowed us to record the actual transfer rates in both directions in one second intervals. The data was transferred using a created data server from which the data was downloaded and on which it was also uploaded. The data sample used had a size of 18100 Mb. During the measurement we observed the extent of limitations that the error rate and packet loss rate parameters had on the data transfer service.

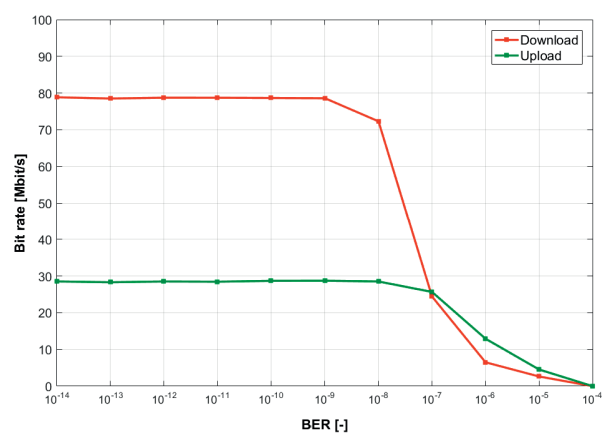

Fig. 14 The effect of BER on the transfer rate - download/upload

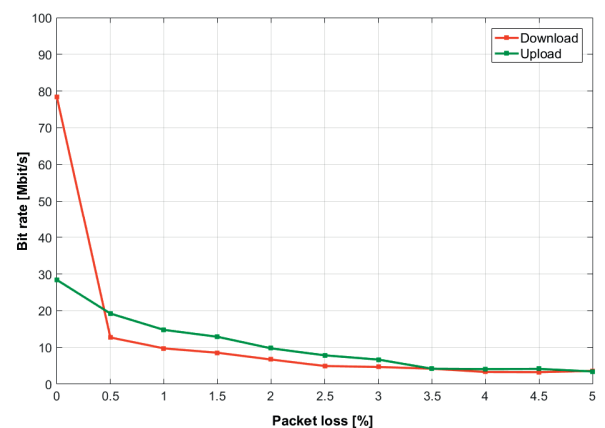

Fig. 15 The effect of packet loss rate on the transfer rate - download/upload

In Fig. 14 we can see the effect that the error rate parameter has on the data transfer. The measurements show that up to BER values of 10^{-9} , the transfer is error-free, but when the values go lower, a drop in transfer rates is apparent in both directions. The complete breakdown occurs at the value of 10^{-4} . Figure 15 describes the effect of the packet loss rate on the data transfer. We can see that the effect of this parameter is more noticeable even at the first step with a packet loss rate of 0.5%, when there is a significant decrease in transfer rates. Increasing the packet loss rate further only causes moderate constant descent of the transfer rate in both directions. The connection still works until the last step of 5%, where the value is around 3.6 Mbps.

5. Conclusion and evaluation

The results of the experimental measurements demonstrate the characteristics of the EPON network that shows itself to be a suitable candidate for the implementation into the infrastructure

with regard to Triple Play services deployment by internet service providers. The paper introduces various measurement options that demonstrate the impact and limits of the parameters affecting the multimedia services and methods for evaluating the quality of Triple Play services. The results show that the most appropriate format for distribution in IPTV services is MPEG-2 HD, which is a sort of compromise between quality and network requirements. For VoIP voice services, the most often used codec is G.711 μ -law. However, in the last test of packet loss rate, the G.729 codec that requires less bitrate has shown better results.

For data services, the essential parameter for an end user is the bandwidth or bitrate, but the error rate or packet loss rate in the network are also quite important. From a global viewpoint, the EPON standard and its extensions are a great choice, as they have excellent transmission characteristics and offer to set up QoS policies in the network for individual multimedia services. The main contribution of this paper is the way in which it is possible to deploy and subsequently evaluate the behaviour of a network

based on the EPON standard and also the deployment of Triple Play services with regard to the evaluation of quality and their demands. The future work will be primarily focused on creating new types of NGA/NGN networks and setting up QoS policies with regard to the parameters critical for the Triple Play services. We will also look at the possibilities of adding new video formats (e.g. UHD, h.265, VP9) [19, 20] or higher transmission rates that will be offered to end users by their providers together with other services (Smart applications, etc.).

Acknowledgement

The research described in this article could be carried out thanks to the active support of the projects No. SP2017/79, SP2017/97, VI20172019071, CZ.1.07/2.3.00/20.0217, CESNET 614R1/2017. The presented research has been supported by project E-infrastructure CESNET - modernization, registration no. CZ.02.1.01/0.0/0.0/16 013/0001797.

References

- [1] LAM, C. F.: *Passive Optical Networks: Principles and Practice*. Elsevier, Boston, p. 324, 2007.
- [2] HENS, F. J., CABALLERO, J. M.: *Triple Play: Building the Converged Network for IP, VoIP and IPTV*. Wiley, Hoboken, p. 401, 2008.
- [3] FRNDA, J., VOZNAK, M., SEVCIK, L.: Impact of Packet Loss and Delay Variation on the Quality of Real-Time Video Streaming. *Telecommunication Systems*, 62(2), 265-275, 2016.
- [4] IFTIKHAR, R., KALEEM, I. M., ABDULLAH, S. M.: *Triple Play Services over EPON Triple Play Services over Ethernet-Passive Optical Networks*. IEEE Symposium, EIR-16(5), Pakistan, 2010.
- [5] FRNDA, J., VOZNAK, M., FAZIO, P., ROZHON, J.: *Network Performance QoS Estimation*. Intern. Conference on Telecommunications and Signal Processing (TSP 2015), Czech Republic, 2015.
- [6] SULTAN, D. M. S., TASLIM, MD. A.: GPON, The Ultimate Pertinent of Next Generation Triple-Play Bandwidth Resolution. *Journal of Telecommunications and Information Technology*, 2, 53-60, 2011.
- [7] LIN, H. -T., LAI, CH.-L., WANG, T.-SH, HUANG, Y.-CH.: *Supporting Triple-Play Services with Private Networking over WDM EPONs*. Intern. Symposium on Communications and Information Technologies (ISCIT 2014), South Korea, 2014.
- [8] LIN, H.-T., LAI, CH.-L., LIU, CH.-L.: Design and Analysis of a Frame-Oriented Dynamic Bandwidth Allocation Scheme for Triple-Play Services over EPONs. *Computer Networks*, 64, 339-352, 2014.
- [9] NIE, Y., YOSHIUCHI, H.: *A Fast Channel Switching Method in EPON System for IPTV Service*. Springer, Berlin Heidelberg, p. 280, 2009.
- [10] HWANG, I.-SH., NIKOUKAR, A.-A., LIEM, A. T., CHEN, K.-CH.: *A New Architecture for Multicasting Live IPTV Traffic in Ethernet Passive Optical Network*. Intern. Conference on Electronics, Computer and Computation (ICECCO 2013), Turkey, 2013.
- [11] YIM, CH., BOVIK, A. C.: Evaluation of Temporal Variation of Video Quality in Packet Loss Networks. *Signal Processing: Image Communication*, 26(1), 24-38, 2011.
- [12] MAKOWSKI, P.: Quality of Variable Bitrate HD Video Transmission in New Generation Access Network. *Journal of Telecommunications and Information Technology*, 1, 21-26, 2014.
- [13] KOCHER, D., KALER, R. S., RANDHAWA, R.: Simulation of Fiber to the Home Triple Play Services at 2Gbit/s using GE-PON Architecture for 56 ONUs. *Optik*, 124(21), 5007-5010, 2013.
- [14] SINGH, S.: Performance Evaluation of Bi-Directional Passive Optical Networks in the Scenario of Triple Play Service. *Optik*, 125(19), 5837-5841, 2014.
- [15] VODRAZKA, J., LAFATA, P.: Transmission Delay Modelling of Packet Communication over Digital Subscriber Line. *Advances in Electrical and Electronic Engineering*, 11(4), 260-265, 2013.

- [16] KOVAC, A., HALAS, M.: E-Model MOS Estimate Precision Improvement and Modelling of Jitter Effects. *Advances in Electrical and Electronic Engineering*, 10(4), 276-281, 2012.
- [17] BIENIK, J., UHRINA, M., VACULIK, M., MIZDOS, T.: Perceived Quality of Full HD Video - Subjective Quality Assessment. *Advances in Electrical and Electronic Engineering*, 14(4), 437-444, 2016.
- [18] UHRINA, M., HLUBIK, J., VACULIK, M.: Correlation between Objective and Subjective Methods Used for Video Quality Evaluation. *Advances in Electrical and Electronic Engineering*, 11(2), 135-146, 2013.
- [19] UHRINA, M., FRNDA, J., SEVCIK, L., VACULIK, M.: Impact of H.264/AVC and H.265/HEVC Compression Standards on the Video Quality for 4K Resolution. *Advances in Electrical and Electronic Engineering*, 12(4), 545-551, 2014.
- [20] UHRINA, M., BIENIK, J., VACULIK, M.: Impact of GoP on the Video Quality of VP9 Compression Standard for Full HD Resolution. *Advances in Electrical and Electronic Engineering*, 14(4), 445-452, 2016.