

Stefan Borik - Ivo Cap - Branko Babusiak *

RESONANT FREQUENCIES OF SMALL ARTERIAL SEGMENTS AS DETERMINING FACTORS FOR ESTIMATION OF TERMINAL SEGMENTS IN ELECTROMECHANICAL ARTERIAL TREE MODEL

A model of the nonsymmetrical arterial tree was analyzed. The arterial branching model was based on the principle of the electromechanical analogy. The nonsymmetrical arterial tree was divided to 7 arterial generations, starting from larger arteries towards small arteries and arterioles. For each generation the resonant frequency and the transfer function were calculated and there are presented the pressure simulation results for each arterial generation. Terminal segments were determined regarding to calculation of the resonant frequencies and the transfer functions and simulation results.

Keywords: Arterial system, electromechanical analogy, outflow condition, resonant frequency, transfer function.

1. Introduction

The arteries deliver a blood containing oxygen to the tissues of whole human body. Blood delivery starts at heart output connected to aortic arterial segments and continues towards the periphery. On the peripheral side of the arterial system small arteries play more than one role such as blood delivering pipelines. They serve for regulation of systemic vascular resistance by changing their radii which are modulated by innervated smooth muscles [1].

2. Material and methods

1.1 Arterial Branching

In this contribution we adopted the results of works which deal with arterial branching questions [2 - 6]. In most cases, the arterial branching consists of mother vessel which bifurcates into two daughter vessels. We can define the daughter vessel radii by Eq. (1) and Eq. (2):

$$r_{d_1} = \alpha r_p \quad (1)$$

$$r_{d_2} = \beta r_p \quad (2)$$

where r_{d_1} are daughter vessel radii, r_p is radius of the mother vessel and α , β are the coefficients modulating the daughter vessel radii [2] and [3].

More information about derivation of the concrete values of the α and β coefficients can be found in the [3] where author defines asymmetry and area ratio of the mother and daughter vessels. Olufsen in [6] combines generalized "Murray's law" [4] and [5] with Zamir's [3] definitions of bifurcating vessel ratios.

Based on these assumptions, we used for our analysis and simulation the following adopted values of parameters [3 - 6]: $\gamma = 0.41$, $\eta = 1.16$, $\xi = 2.76$, $\alpha = 0.91$ and $\beta = 0.58$.

1.2 Model of Arterial System Based on Electromechanical Analogy

The properties of the arterial system can be transformed by using appropriate electromechanical analogies to system consisting of discrete electrical elements such as resistor, inductor or capacitor [7 - 10]. A blood pressure is equivalent to electrical voltage and a blood flow can be modeled as electrical current. These equivalences can be used in the case when we divide the modeled arterial tree to the discrete arterial segments with defined length. We used for our simulation of arterial system behavior the model consisting of interconnection of single vessel segments (see Fig. 1).

* Stefan Borik, Ivo Cap, Branko Babusiak

Department of Electromagnetic and Biomedical Engineering, Faculty of Electrical Engineering, University of Zilina, Slovakia
E-mail: stefan.borik@fel.uniza.sk

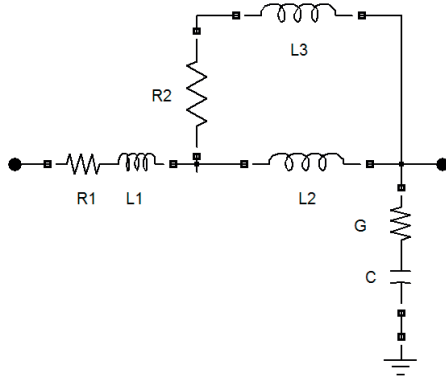

Fig. 1 Vessel segment model

The single element values can be determined [7] and [8]:

$$R_n = 2nR_0, L_n = \frac{1}{2n-1}L_0, n = 1, 2, 3, \dots \quad (3)$$

$$R_0 = \frac{4\eta}{\pi r_0^4}, L_0 = \frac{\rho}{\pi r_0^2} \quad (4)$$

$$C = \frac{2\pi r_0^2}{k_w E_{stat}}, G = \frac{2\pi r_0^2}{k_w \eta}, k_w = \frac{2h(2r_0 + h)}{3(r_0 + h)^2} \quad (5)$$

The meaning of the elements, which are described by (3), (4) and (5), is listed in Table 1 [7] and [8].

Elements and parameters of the vessel segments Table 1

Element/Parameter	Description	Unit
R_n	Specific resistance of the appropriate vessel segment	$[\Omega \cdot m^{-1}]$
L_n	Specific inductance of the appropriate vessel segment	$[H \cdot m^{-1}]$
C	Specific capacitance of the appropriate vessel segment	$[F \cdot m^{-1}]$
G	Specific conductance of the appropriate vessel segment	$[S \cdot m^{-1}]$
r_0	Radius of the appropriate vessel segment	[mm]
η	Blood viscosity	[mPa·s]
ρ	Blood density	$[kg \cdot m^{-3}]$
k_w	Geometrical factor	[-]
E_{stat}	Static elastic modulus	[MPa]
h	Vessel wall thickness	[mm]

1.3 Small arteries branching implementation

Before implementation of small artery models to existing model of arterial system involving the large arteries, it is needed to determine a finishing radius of last arterial generation. Radii of arterioles vary from 5 to 30 μm [1]. Therefore the new generation of small arteries should be finished when their radii

are approximately equal to arteriole radii. We attempted to solve this problem in another way.

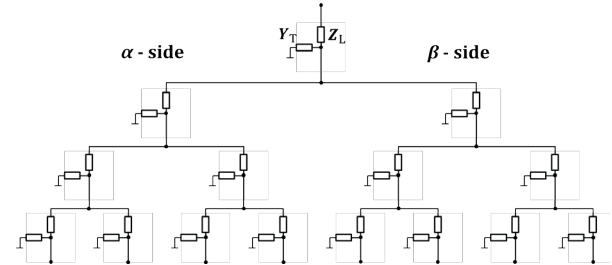

Fig. 2 Small arteries branching schematic

1.4 Transfer Function of Single Arterial Segments

At first, we made an analysis of transfer function of arterial segments placed in the single generations (see Fig. 2). Pressure or voltage transfer function of the single segments is defined by:

$$H_U(\omega) = \frac{\dot{U}_2}{\dot{U}_1} \quad (6)$$

where \dot{U}_2 is output harmonic voltage of the simplified arterial segment (see Fig. 3) and \dot{U}_1 is input harmonic voltage of this segment. According to the theory of electromechanical analogy the voltage is interconnected with the pressure in physiological segment described by its mechanical properties.

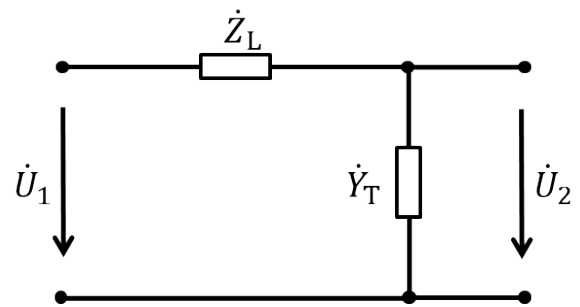

Fig. 3 Simplified arterial segment

Then we can express the voltage \dot{U}_2 by using relation for voltage divider and we get the equation for the voltage transfer

function $\dot{H}_U(\omega)$ in the following form:

$$\dot{H}_U(\omega) = \frac{1}{1 + \dot{Z}_L \dot{Y}_T} \quad (7)$$

where \dot{Z}_L is longitudinal impedance of arterial segment in Fig. 1 and \dot{Y}_T is transversal admittance of this segment.

Both parts of this basic arterial segment model can be expressed by (8) and (9):

$$\dot{Z}_L = R_1 + j\omega L_1 + \frac{j\omega L_2(R_2 + j\omega L_2)}{j\omega L_2 + R_2 + j\omega L_3} \quad (8)$$

$$\dot{Y}_T = \frac{j\omega GC}{G + j\omega C} \quad (9)$$

The meaning of the elements used in (8), (9) is listed in Table 1.

From the point of view of the electrical circuit theory, we can express impedance of the unloaded segment such as the serial connection of its longitudinal impedance (8) and reciprocal of its transversal admittance (9):

$$\dot{Z} = \dot{Z}_L + \frac{1}{\dot{Y}_T} \quad (10)$$

The total impedance will be helpful at analysis of transfer characteristics of the single arterial segments placed in different generations. Concretely, there are resonant frequencies which are indicators of the arterial segment properties regarding to inductive and capacitive properties of the equivalent electrical circuit (Figs 1 - 3). The resonant frequency of the corresponding segment (see two-port circuit in Fig. 3) is determined by equaling of the imaginary part of the total impedance to zero:

$$\text{Im}\{\dot{Z}\} = 0 \quad (11)$$

Having expressed the single elements and edited the Eq. (6), we get a biquadratic equation:

$$\text{Im}\{\dot{Z}\} = \omega L_1 + \frac{\omega^3 (L_2^2 L_3 + L_2 L_3^2) + \omega L_2 R_2^2}{(\omega L_2 + \omega L_3)^2 + R_2^2} - \frac{1}{\omega C} = 0 \quad (12)$$

which has 4 roots but only one of them is positive. Then for resonant frequency, we obtain the following relation:

$$\omega_r = \sqrt{\frac{\sqrt{\left(C^2 L_1^2 R_2^4 + 2C^2 L_1 L_2 R_2^4 + C^2 L_2^2 R_2^4 + 2CL_1 L_2^2 R_2^2 + 4CL_1 L_2 L_3 R_2^2 + 2CL_1 L_3^2 R_2^2 - 2CL_2^2 R_2^2 + 2CL_2 L_3^2 R_2^2 + L_2^4 + 4L_2^3 L_3 + 6L_2^2 L_3^2 + 4L_2 L_3^3 + L_3^4 + L_2^2 + L_3^2 + 2L_2 L_3 - CL_1 R_2^2 - CL_2 R_2^2 \right)}{(2CL_2^2 L_3 + 2CL_1 L_2^2 + 2CL_2 L_3^2 + 4CL_1 L_2 L_3 + 2CL_1 L_3^2)}} \quad (13)$$

The values of the resonant frequencies of the arterial segments placed in the different generation are listed in Table 2.

Resonant frequencies of the arterial segments placed in the different generations Table 2

Generation	α-side		β-side	
	ω _r [rad·s ⁻¹]	f _r [Hz]	ω _r [rad·s ⁻¹]	f _r [Hz]
Mother vessel	97.12	15.46	97.12	15.46
1.	111.98	17.82	221.94	35.326
2.	129.15	20.55	508.25	808.90
3.	149.01	23.72	1147.91	1826.96
4.	171.98	27.37	2526.53	4021.10
5.	198.53	31.60	5406.21	8604.25
6.	229.21	36.48	11319.73	18015.91
7.	264.64	42.12	23402.74	37246.62

3. Results

3.1 Determination of outflow condition

As written in the text above, we used the calculation of the transfer functions for assessment of the properties of the single arterial segments. They can be used for determination of outflow conditions of the segments placed in the last generation of small arteries, concretely in our case in the 7th generation. We can list several approaches how to determine an element which finishes arterial tree. We can start with “windkessel” models and continue with simple resistive elements which represent resistive nature of capillary bed [11] and [12].

In our contribution we focus on determining outflow condition in the following way: in the real world the arterial tree consists of approximately 20 generations. It follows from that there are 2²⁰ elements needed for modeling the last generation [2] and [11]. By using the calculation of the transfer functions we can estimate “cut-off” generation which means that we can determine when we can stop the generating of new elements and by that way it is possible to minimize computing costs of computer simulation. In our work we set the threshold for stopping generating of the new segments by observing the resonant properties of the single segments on the alpha and beta sides of the particular arterial generations.

As defined by (1) and (2) the radius of the new segment descends much slower on the alpha side than on the beta side of the modeled arterial tree. It follows from Fig. 4 which characterizes transfer functions of arterial tree segments (see Fig. 2) on the alpha side. The change in resonant frequency is much evident in single generations on the beta side of arterial bed (Fig. 5).

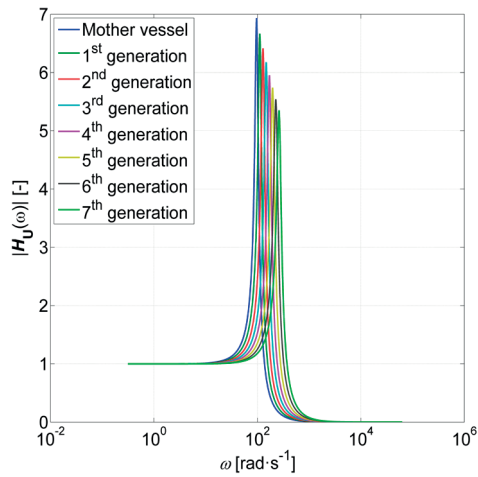

Fig. 4 Transfer function of single generations - α -side

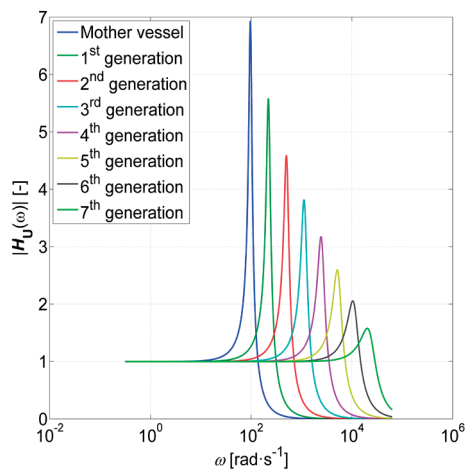

Fig. 5 Transfer function of single generations - β -side

We performed the simulations of the model of arterial tree consisting of small arteries towards arterioles. This model was implemented to the existing model of arterial system based on electromechanical analogy. Comparing to the previous arterial tree model [7 - 10], where the arterial peripheral segments were ended by terminal segments at the level of large arteries, the arterial branching continues to the seventh arterial generation in our implementation. Input signal of this branching extension corresponds to the mother vessel curve (blue line - see Fig. 6). The radii of the segments placed on the left side of the modeled arterial tree are around $45 \mu\text{m}$ (see Fig. 7) which is value close to arteriolar tree border (arterioles have resistive character and serve for peripheral vascular resistance regulation [1]). The simulated pressure values (see Fig. 6) in the seventh generation correspond to pressure values measured in arteriolar tree [1].

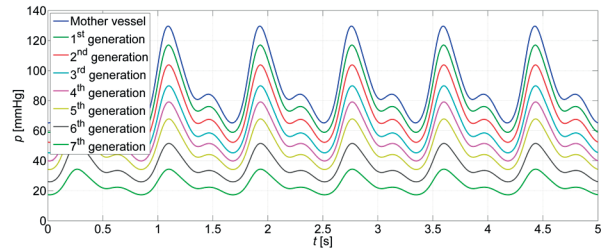

Fig. 6 Simulation results - blood pressure in particular vessel generations

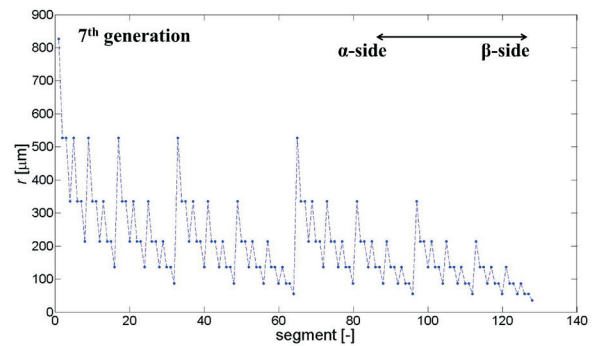

Fig. 7 The arterial radii in dependence on their position within the model of the small arteries

4. Conclusion

We estimated the criteria for stopping of creation of the new elements in the next generation by evaluating the resonant peaks in single transfer functions. The segment placed on the beta side of modeled arterial tree has resonant frequency approximately equal to $10^4 \text{ rad}\cdot\text{s}^{-1}$. It is negligible from the point of view of possible heart rate frequencies which can exist in arterial system. Therefore, we can assume that the segments placed in the seventh generation have resistive character in the range of the possible heart rate frequencies and with them connected upper harmonic components which form the basic pulse wave propagating through arteries and they can be finished by simple resistive elements - resistors with values comparable to total resistance of the previous segment.

The modeling of the vascular system by using the electromechanical analogies can lead to better understanding of processes which occur in arteries. Also it could be possible to evaluate the degree of pathological changes in arterial system by using appropriate measurement methods (e.g. photoplethysmography) [13] and by reverse comparing of measured and simulated data. In this way the malformation such as arterial stenosis or aneurysm could be deeply studied.

References

- [1] JAVORKA, K., BEDER, I.: *Medical Physiology (in Slovak)*. Osveta, Martin, 2001.
- [2] OLUFSEN, M. S., PESKIN, C. S., KIM, W. Y., PEDERSEN, E. M., NADIM, A., LARSEN, J.: Numerical Simulation and Experimental Validation of Blood Flow in Arteries with Structured-tree Outflow Conditions. *Annals of Biomedical Engineering*, 28(11), 2000, pp. 1281-1299.
- [3] ZAMIR, M.: Nonsymmetrical Bifurcations in Arterial Branching. *J. of General Physiology*, 72(6), 1978, pp. 837-845.
- [4] MURRAY, C. D.: *The Physiological Principle of Minimum Work: I. The Vascular System and the Cost of Blood Volume*. Proc. of the National Academy of Sciences of the United States of America, 1926, 12.3: 207.
- [5] UYLINGS, H. B. M.: Optimization of Diameters and Bifurcation Angles in Lung and Vascular Tree Structures. *Bulletin of Mathematical Biology*, 39(5), 1977, pp. 509-520.
- [6] OLUFSEN, M. S.: Structured Tree Outflow Condition for Blood Flow in Larger Systemic Arteries. *American J. of Physiology - Heart and Circulatory Physiology*, 276(1 45-1), 1999, pp. H257-H268.
- [7] CAP, I., CZIPPELOVA, B.: Electromechanical Model of Blood Flow in Vessels. *Advances in Electrical and Electronic Engineering*, 7(1-2), 2011, pp. 338-341.
- [8] GOMBARSKA, D., CZIPPELOVA, B.: Computer Simulation of Human Cardiovascular System. *Acta Technica CSAV*, 57(4), pp. 407-420, 2012.
- [9] CZIPPELOVA, B., GOMBARSKA, D.: Modelling of Arterial Bifurcation by Means of Electromechanical Model with Distributed Parameters, *Communications - Scientific Letters of the University of Zilina*, 13(1), 2011, pp. 22-26.
- [10] GOMBARSKA, D., CZIPPELOVA, B., CAP, I.: The Investigation of Terminal Segment Effect on Blood Pressure Propagation Patterns in Cardiovascular System Models, *Communications - Scientific Letters of the University of Zilina*, 13(2A), 2011, pp. 38-43.
- [11] OLUFSEN, M. S., NADIM, A.: On Deriving Lumped Models for Blood Flow and Pressure in the Systemic Arteries. *Math Biosci Eng*, 1(1), 2004, pp. 61-80.
- [12] STERGIOPULOS, N., WESTERHOF, B. E., WESTERHOF, N.: Total Arterial Inertance as the Fourth Element of the Windkessel Model. *American J. of Physiology - Heart and Circulatory Physiology*, 276(1 45-1), 1999, pp. H81-H88.
- [13] BLAZEK, V.: Biomedical Technology - 2011 and beyond. *Communications - Scientific Letters of the University of Zilina*, 13(1), 2011, pp. 5-12.