

Milan Vasko – Ardeshir Guran – Lenka Jakubovicova – Peter Kopas *

DETERMINATION THE CONTACT STRESS DEPENDING ON THE LOAD RATE OF THE NU220 ROLLER BEARING

The purpose of this paper is to present the impact magnitude of the load rate of the roller bearing at mutual slewing of roller bearing rings to the process of contact stresses in rolling element. The roller bearing satisfies prescribed basic static load capacity if it is loaded by the maximum specified load only in the radial direction according to the ISO / TS 16281. The basic static radial load capacity of the cylindrical roller bearing determines the maximum loading for which there is no plastic deformation in the raceways yet. However, the real roller bearings are not loaded only in the radial direction in practice. During operation there exists a mutual slewing of the roller bearing rings. This leads to a change in the conditions of contact and contact stresses. The analysis of the mutual influence of these two parameters was made using finite-element software ADINA.

Keywords: Roller bearing, rating life, contact mechanics, Hertz contact stress, FEM, computational analysis, stress analysis, ADINA.

1. Basic static load capacity of the cylindrical roller bearing

If the static loads are acting on the rolling elements and raceways of bearings, permanent deformations are rising and they will increase with loads enlarging. It is difficult to determine the degree of deformation arising in the test of bearings at specific conditions. It is therefore necessary to develop a different method for determination of suitability of the selected bearing. Based on the experience an international technical standard (Technical specification: Rolling bearing – Methods for calculating the modified reference rating life for universally loaded bearings) was established [1, 2].

The total permanent deformation of 0.0001 diameter size of rolling elements in the most loaded contact zone of rolling elements and the raceway in many cases of the mounting does not effect the subsequent impairment of bearings function [3, 4]. The deformation arises from an equivalent load which is equal to the calculated bearing load capacity.

Radial static load for different types of bearings is:

- 4600 MPa - for two-row self-aligning ball bearings,
- 4200 MPa - for all other ball bearings,
- 4000 MPa - for all cylindrical roller bearings (roller, needle, spherical, tapered) which correspond to computational contact stresses in the centre of the most loaded contact zone of rolling element with the raceway.

The static central load is:

- 4200 MPa - for axial ball bearings,
- 4000 MPa - for all axial cylindrical roller bearings (roller, needle, spherical, tapered).

Basic radial static load capacity C_{or} for the roller bearings is [1]

$$C_{or} = 44 \left(1 - \frac{D_{we} \cdot \cos \alpha}{D_{pw}} \right) i Z L_{we} D_{we} \cdot \cos \alpha, \quad (1)$$

D_{we} - roller diameter applicable in the calculation of load rating,
 D_{pw} - pitch diameter of roller elements,
 Z - number of rolling elements,
 L_{we} - effective roller length.

The main focus of this article is to analyze roller bearings stresses by Finite Element Method [5]. The outer and inner ring of a cylindrical roller bearing will be slewed against each about the specified angle $\varphi = 0', 2', 4', 6', 8'$ (Fig. 1).

The safety coefficient f_s represents a degree of safety against too high plastic deformations at the rolling elements contact points [6]. If the bearings have easy and especially silent rotation, they require the high value of safety coefficient

$$f_s = \frac{C_{or}}{P_{or}}, \quad (2)$$

$f_s = 2.5$ to 4 - for extremely high requirements,
 $f_s = 1.2$ to 2.5 - for high requirements,
 $f_s = 0.8$ to 1.2 - for normal requirements,
 $f_s = 0.5$ to 0.8 - for low requirements.

P_{or} is the static equivalent radial force in Newtons. Especially high safety factor is required for structures that have higher requirements for safety (bearings used in wind turbines, lifts gearboxes, wheels for railway carriages, etc.) [7, 8]. The roller bearing load

* Milan Vasko¹, Ardeshir Guran², Lenka Jakubovicova¹, Peter Kopas¹

¹Department of Applied Mechanics, Faculty of Mechanical Engineering, University of Zilina, Slovakia, E-mail: milan.vasko@fstroj.uniza.sk

²Institute of Structronics, Ottawa, Canada

represents 0.25 to 1 times the basic static load capacity of the bearing, i.e. rate of load $f_F = 0.25$ to 1. The results for the load rate $f_F = 1$ will be referred in this article [9]. Finally, the results will be evaluated in cooperation of both applied parameters.

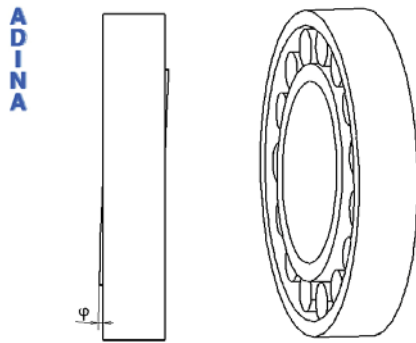

Fig. 1 Mutual slewing of the roller bearing rings together with rolling elements

2. Calculation of logarithmic roller profile and basic static radial load capacity

If a purely cylindrical roller is loaded, edge stresses will occur, which can substantially exceed the calculated Hertzian pressure.

Therefore the rollers are usually profiled; they are produced to the roller bearing with logarithmic profile or “KB” profiles [2, 10].

In our case, the profile of a roller bearing element is logarithmic [11]. For rollers having a length $L_{we} \leq 2.5D_{we}$ a stepwise defined profile function $P(x_k)$ is

$$P(x_k) = 0.00035D_{we} \cdot \ln \left[\frac{1}{1 - (2x_k/L_{we})} \right], \quad (3)$$

where x_k is x-coordinate from the center of roller. The analysis of the mutual influence of load rate and slewing of roller bearing rings was made for the NU220 single row cylindrical roller bearing.

By substituting the basic bearing dimensions into equation (1) the value of the basic radial load capacity $C_{or} = 300848$ N is obtained. FE calculations were made for the rate of load $f_F = 1$, therefore the applied loading radial force from equation (2) is $P_{or} = 300848$ N.

3. Preparation of a model for FE analysis

A quarter of the roller bearing model was built for the purposes of the analysis. FE software ADINA was used for FE analysis. In the model, the profile of the roller bearing element is logarithmic. Eight-node quadratic elements were used to create a finite element mesh for the FE model (Fig. 2). The mesh size was 2 mm in meshing of the model. The higher mesh density was used in the

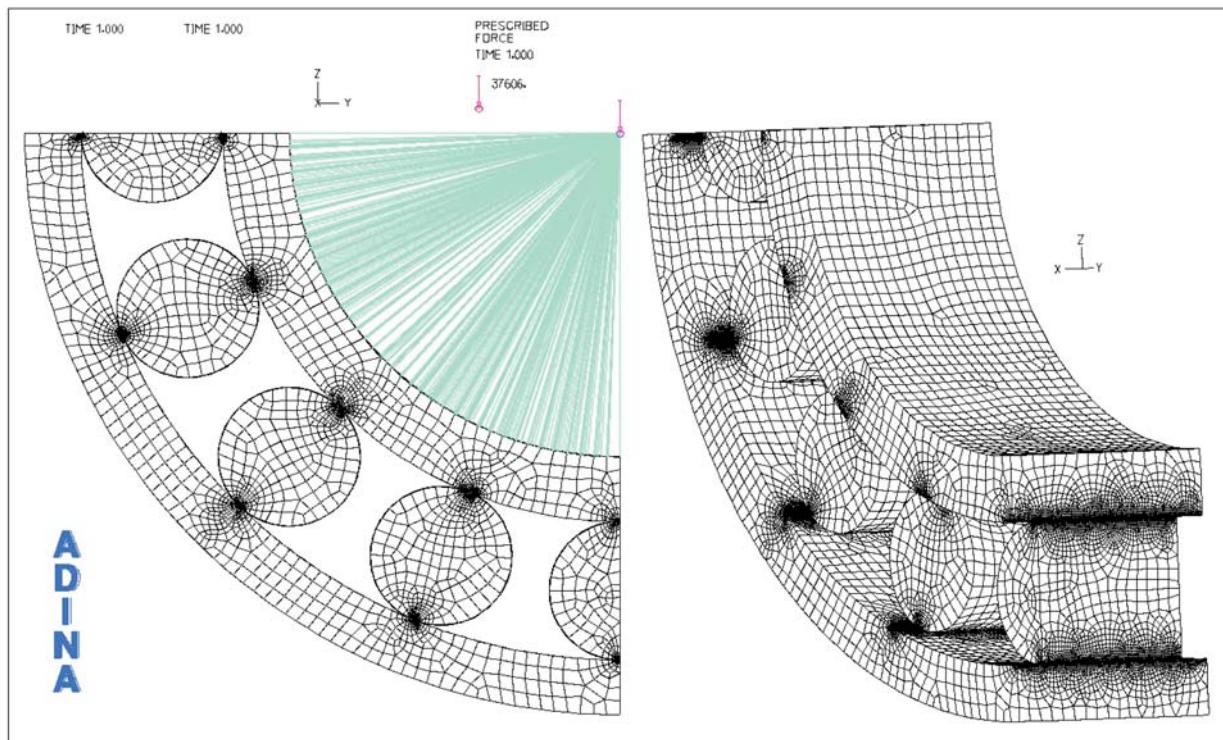

Fig. 2 FE model created by software ADINA

inner and outer rings contact point of rolling elements [12]. At least 6 elements on the contact ellipse width were used.

According to [13], the width of the contact ellipse is $b = 0.74 \cdot 10^{-3}$ m. The isotropic linear elastic material was used ($E = 2.11 \cdot 10^5$ MPa, $\mu = 0.3$) [14]. The shaft was replaced by constrains. The non-linear contact problem was solved by Full-Newton iteration method.

4. Stress-strain FE analysis

Stress state is evaluated in the most loaded element of the roller bearing (on the surface of contact area). $P1$, $P2$ and $P3$ stresses are evaluated at gradual slewing of the roller bearing rings, angle $\varphi = 0'$ to $8'$ [15]. The step is $\Delta\varphi = 2'$.

The maximum value of $P3$ stress at the angle $\varphi = 0'$ is 3808 MPa and at the angle $\varphi = 8'$ it is 4220 MPa. The increase in the value of $P3$ stress is 10.82%. Table 1 shows a gradual increase in the value of $P1$, $P2$ and $P3$ stresses at gradual slewing of roller bearing rings. The load rate $f_F = 1$. The increase in the maximum value of stress is quadratic [16, 17].

The maximum contact stresses at the point of contact on the roller surface were evaluated. However, the maximum stress arises

Maximum contact stresses at the point of contact on the roller surface at gradual slewing of roller bearing rings, $f_F = 1$ Table 1

Angle φ	P1 stress [MPa] - [%]	P2 stress [MPa] - [%]	P3 stress [MPa] - [%]
0'	-2010 (0%)	-3040 (0%)	-3808 (+0%)
2'	-2024 (+0.69%)	-3080 (+1.32%)	-3840 (+0.84%)
4'	-2060 (+2.48%)	-3160 (+3.95%)	-3935 (+3.34%)
6'	-2100 (+4.47%)	-3270 (+7.56%)	-4100 (+7.67%)
8'	-2140 (+6.46%)	-3390 (+11.5%)	-4220 (+10.82%)

below the surface of the roller and its size is 4000 MPa. This is in accordance with the values prescribed by the norm.

The stresses at slewing of roller bearing rings by the angle $\varphi = 0'$ and $\varphi = 8'$ are shown in Figs. 4 and 5.

The bearing is loaded with the maximum allowable static load. We can see the formation of edge stresses in Figs. 4 and 5. They are greater at slewing of roller bearing rings by the angle $\varphi = 8'$. In this case the permanent plastic deformations arise in the bearing. This is unwanted effect for the safe bearing run in practice.

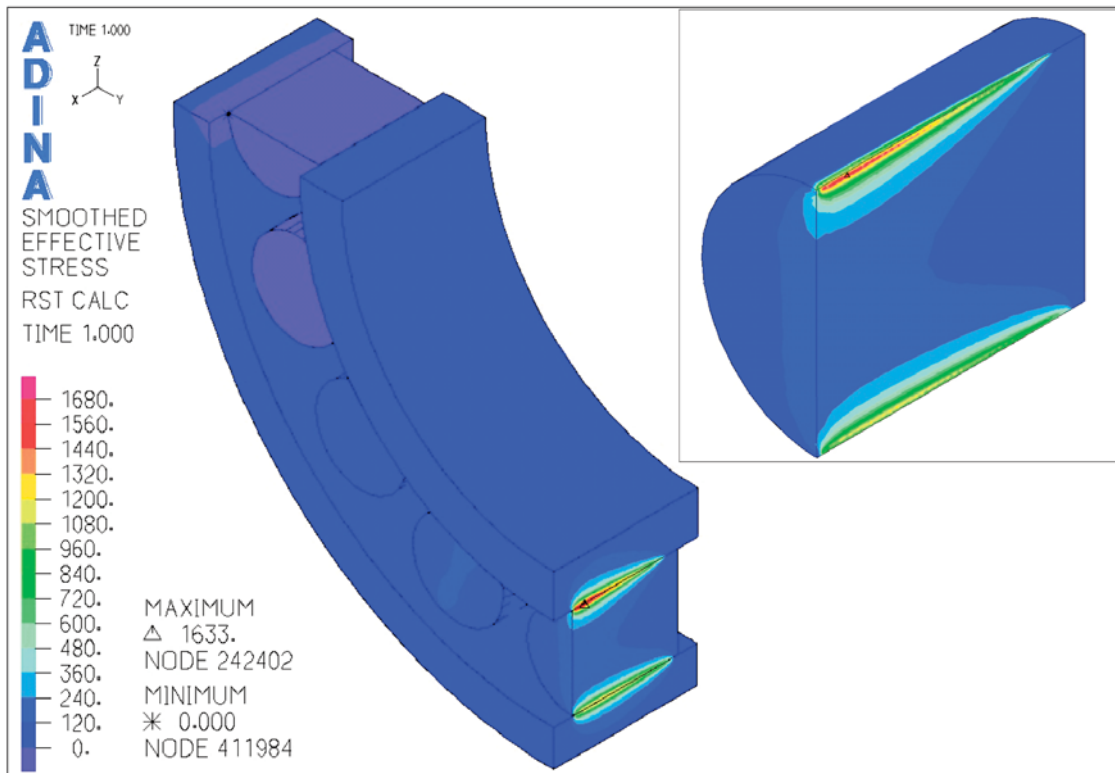

Fig. 3 Effective stress, load rate $f_F = 0.25$, angle $\varphi = 8'$

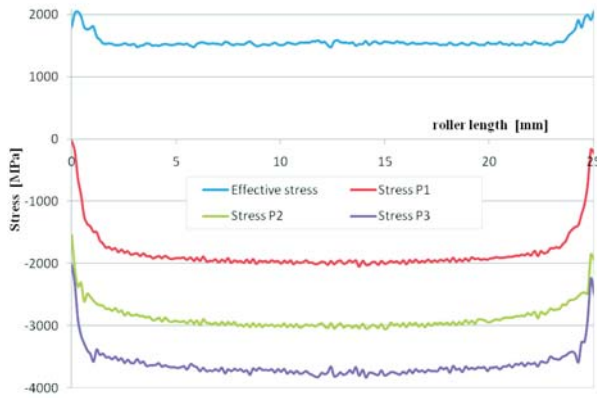

Fig. 4 Stresses at slewing of roller bearing rings by the angle $\varphi = 0'$, $f_F = 1$

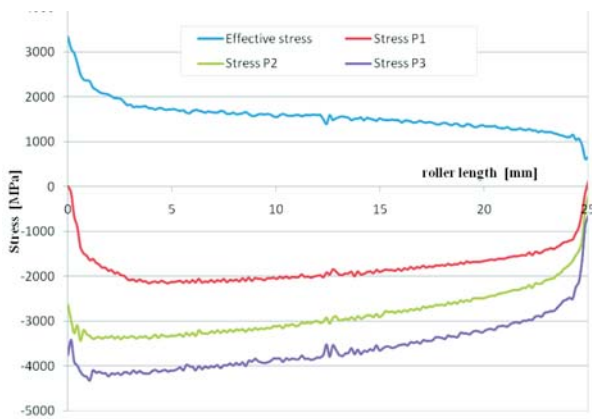

Fig. 5 Stresses at slewing of roller bearing rings by the angle $\varphi = 8'$, $f_F = 1$

The P1, P2 and P3 stress at gradual slewing of roller bearing rings by the angle $\varphi = 0'$ to $8'$ are shown in Figs. 6 to 8.

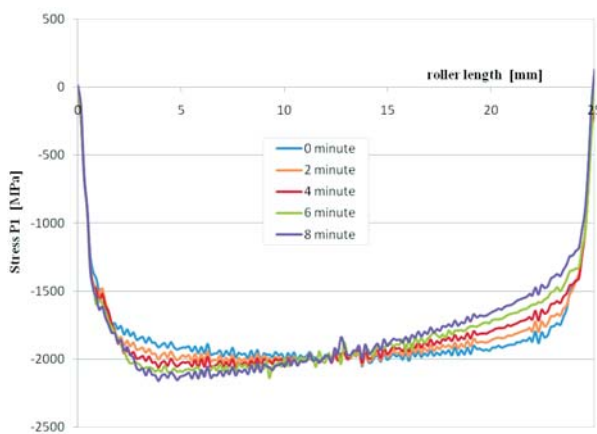

Fig. 6 P1 stress at gradual slewing of roller bearing rings by the angle $\varphi = 0'$ to $8'$, $f_F = 1$

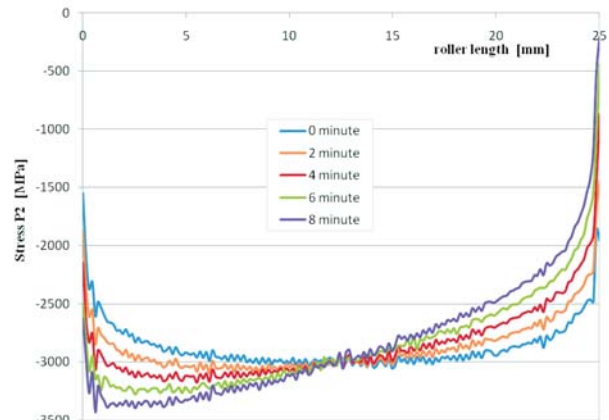

Fig. 7 P2 stress at gradual slewing of roller bearing rings by the angle $\varphi = 0'$ to $8'$, $f_F = 1$

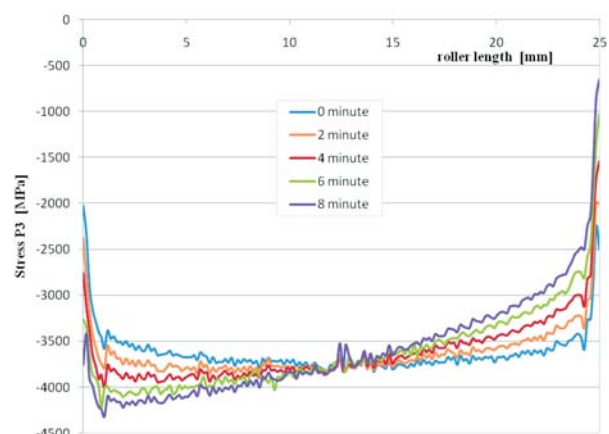

Fig. 8 P3 stress at gradual slewing of roller bearing rings by the angle $\varphi = 0'$ to $8'$, $f_F = 1$

The maximum stresses on the roller will be analyzed in the next section. The dependence between the load rate and slewing of roller bearing rings is shown in Fig. 9. In this figure, the values of the slewing angle were approximated by the polynomial of 3rd degree and load rate values were approximated by the polynomial of 2nd degree.

In the equation (4) is the consequential polynomial which describes the entire surface of stresses. RMSE represents the root mean squared error or standard error. A value closer to zero indicates a fit that is more useful for prediction; for our resultant polynomial it takes the value of 30.42.

For the loaded roller bearing with similar dimensions the increase of contact stress P3 can be estimated by the polynomial function mentioned above.

Fig. 10 shows the Mohr's circles at gradual slewing of roller bearing rings by the angle $\varphi = 0'$ to $8'$ and the rate of load $f_F = 1$.

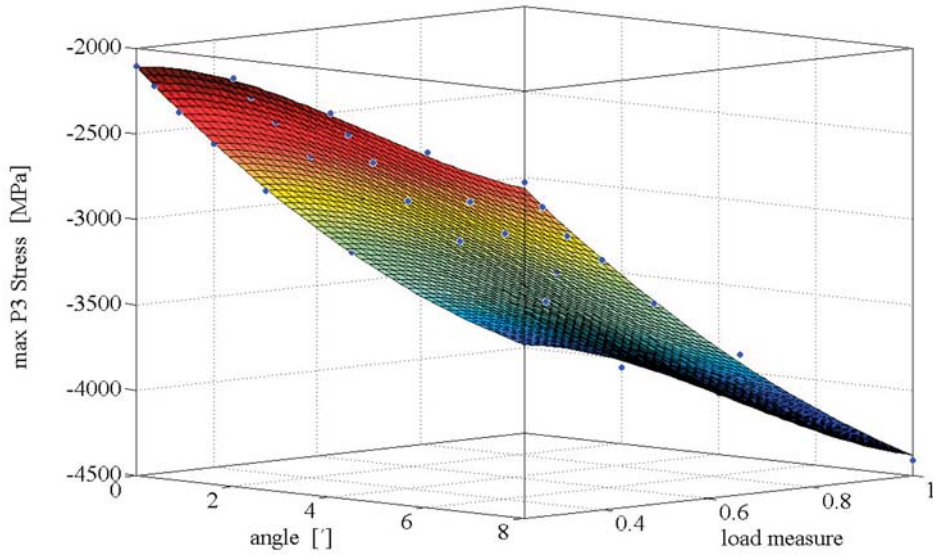

Fig. 9 P3 stress (contact stress) at gradual slewing of roller bearing rings by the angle $\varphi = 0'$ to $8'$ and at gradual change of load rate $f_F = 0.25$ to 1

$$[-1146 \ 31.95 \ -4177 \ -27.37 \ 24.35 \ 1341 \ 1.851 \ 3.11 \ -30.43] \cdot \begin{bmatrix} 1 \\ \varphi \\ f_F \\ \varphi^2 \\ \varphi f_F \\ f_F^2 \\ \varphi^3 \\ \varphi^2 f_F \\ \varphi f_F^2 \end{bmatrix} = P3 \quad (4)$$

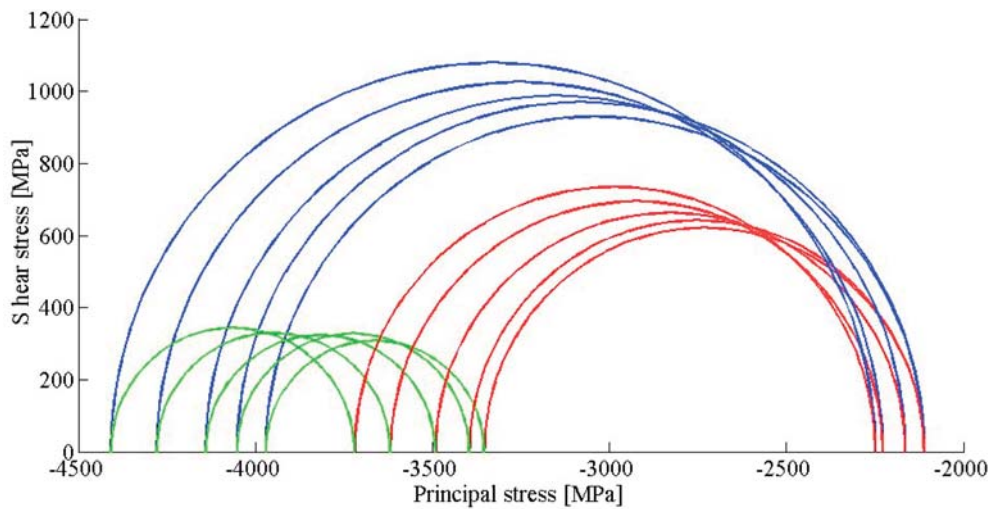

Fig. 10 Mohr's circles at gradual slewing of roller bearing rings by the angle $\varphi = 0'$ to $8'$, the load rate $f_F = 1$

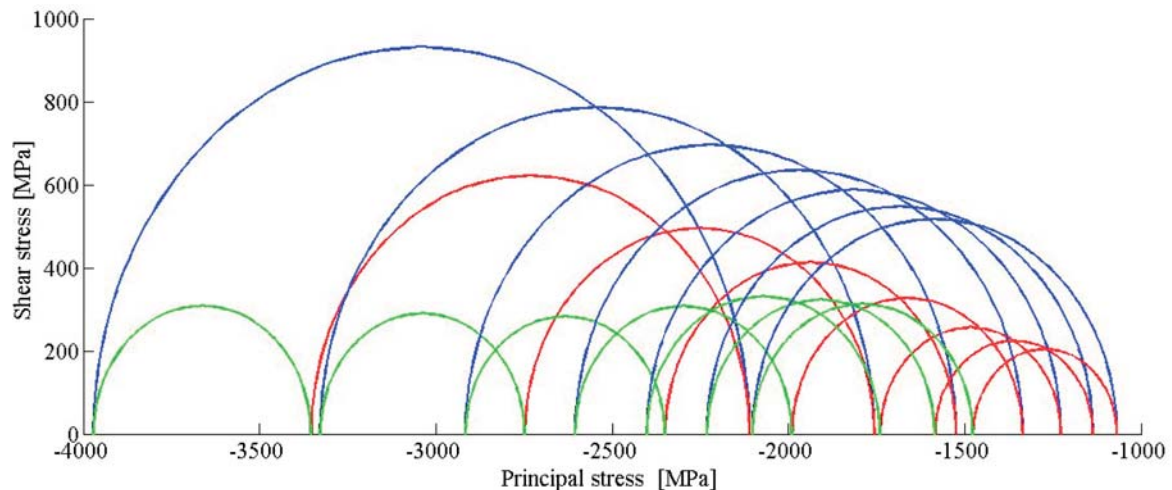

Fig. 11 Mohr's circles at gradual change of load rate $f_F = 0.25$ to 1, the slewing of roller bearing rings by the angle $\varphi = 0'$

Fig. 11 shows the Mohr's circles at gradual change of load rate $f_F = 0.25$ to 1 and the slewing of roller bearing rings by the angle $\varphi = 0'$.

5. Conclusion

The paper deals with the magnitude of the contact of roller bearing rings mutual slewing to the process of contact stresses in rolling elements. This mutual slewing of the bearing roller rings leads to a change in contact stresses and conditions of contact.

If the bearing is exposed to the high load which makes slewing of roller bearing rings during the operation, it is necessary to reduce

the loading. The loading reduction will ensure that the load does not exceed the maximum allowed values specified by the norm and there will be no plastic deformations of rolling elements on the raceway.

The main goal of this article was to analyze roller bearings stresses by FEM. For the analysis of this problem we used the finite-element program ADINA. The set of calculations in the gradual change of load rate f_F were realized with the various values of the slewing of roller bearing rings.

Acknowledgements

This work has been supported by VEGA grant No. 1/1089/11 and KEGA grant No. 004ZU-4/2012.

This contribution is the result of the project implementation: Development of optimum technology for the analysis of limit states of structural elements in contact, ITMS code 26220220118, supported by the Research & Development Operational Programme funded by the ERDF.



We support research activities in Slovakia /
The project is co-financed by the European Union.

References

- [1] British/International Standard BS ISO/281 (2007). *Rolling bearings - Dynamic load ratings and rating life*.
- [2] Technical specification ISO/TS 16281 (2008). *Rolling bearings - Methods for calculating the modified reference rating life for universally loaded bearings*.

- [3] JAKUBOVICOVA, L., VASKO, M., KOMPIS, V. Trefftz Functions Using the Fundamental Solution with the Singularity Outside the Domain. *Computer Assisted Mechanics and Eng. Sciences*, 2003, vol. 10, No. 4, pp. 515-521. ISSN 1232-308X.
- [4] ZMINDAK, M., RIECKY, D.: Meshless Modelling of Laminate Mindlin Plates under Dynamic Loads. *Communications - Scientific Letters of the University of Zilina*, 2012, vol. 14, No. 3, pp. 24-31. ISSN 1335-4205.
- [5] BATHE, K. J.: *Finite Element Procedures*. New Jersey, Prentice Hall, 1982. ISBN 0-13-301456-4.
- [6] HILLS, D. A., NOWELL, D., SACKFIELD, A.: *Mechanics of Elastic Contacts*. Butterworth & Heinemann, Oxford, 1993. ISBN 0-7506-0540-5.
- [7] BOKUVKA, O., NOVY, F., MINTACH, R., CINCALA, M.: Influence of Loading Type on the Shape of Fatigue Lifetime Curve. *Int. J. of Applied Mechanics and Engineering*, 2010, vol. 15, No. 2, pp. 321-328. ISSN 1425-1655.
- [8] SAGA, M.: Contribution to the Analysis of Non-stationary Radnom Vibration of Vehicles, *Communications - Scientific Letters of the University of Zilina*, 2001, vol. 3, No. 1, pp. 35-43, ISSN 1335-4205.
- [9] SAGA, M., LETRICH, M., KOCUR, R.: An Analysis of Vehicle Vibration with Uncertain System Parameters. *Communications - Scientific Letters of the University of Zilina*, 2005, vol. 7, No. 1, pp. 16-21, ISSN 1335-4205.
- [10] JAEGER, J.: *New Solutions in Contact Mechanics*. WIT Press, Southampton : Boston, 2005. ISBN 1-85312-994-1.
- [11] JOHNSON, K. L.: *Contacts Mechanics*. Cambridge University Press : Cambridge, 1985. ISBN 0-521-25576-7.
- [12] MELICHER, R., HANDRIK, M.: Analysis of Shape Parameters of Tool for ECAP Technology. *Acta Mechanica Slovaca*, 2008, vol. 12, No. 3C, pp. 273-284. ISSN 1335-2393.
- [13] http://www.tribology-abc.com/calculators/e2_3.htm.
- [14] VASKO, A.: Image Analysis in Materials Engineering. *Konferencje, Poland*. 2007, No. 61, pp. 667-670. ISSN 1234-9895.
- [15] SAPIETOVA, A., SAGA, M., NOVAK, P.: Multi-software Platform for Solving of Multibody Systems Synthesis. *Communications - Scientific Letters of the University of Zilina*, 2012, vol. 14, No. 3, pp. 43-48. ISSN 1335-4205.
- [16] SAGA, M., VASKO, M.: Stress Sensitivity Analysis of the Beam and Shell Finite Elements. *Communications - Scientific Letters of the University of Zilina*, 2009, vol. 11, No. 2, pp. 5-12. ISSN 1335-4205.
- [17] SAGA, M., VAVRO, J.: Contribution to Non-Proportional Multiaxial Fatigue Analysis by FEM. *Materials Engineering*, 2004, vol. 11, No. 1, pp. 143-150, ISSN 1335-0803.