

Michal Frivaldsky – Branislav Dobrucky – Giacomo Scelba – Pavol Spanik – Peter Drgona \*

## BIDIRECTIONAL STEP-UP/STEP-DOWN DC-DC CONVERTER WITH MAGNETICALLY COUPLED COILS

*The paper is focused on bidirectional up/down DC-DC converter with magnetically coupled coils (MCC), which can be utilized as a part of power semiconductor system in traction, automotive, or industrial applications like renewable energy sources. Proposed solution of main circuit of bidirectional converter should serve for energy transfer from source to load, and vice versa, whereby parameters of electrical variables like voltage, current and power are able to be adapted based on the current requirements of application. Their values can be increased or decreased in first (energy transfer from source to load) or in third (energy transfer from load to source) quadrant of converter's operation. The boost effect of output voltage can be increased - if it is not sufficient one - by appropriate ratio of number of inductor windings.*

**Keywords:** DC-DC power converter, bidirectional step-up/step-down converter, duty cycle factor, transfer function, parasitic parameters, steady-state operation.

### 1. Introduction

Process of energy recuperation is well known phenomena, especially in the field of traction applications. Nowadays, the recuperation of energy is used in the industrial, commercial and also in the consumer sector. The main factor, which allows this breakthrough, was development of technology in production of power semiconductor structures and research of new topologies of main circuit of switched mode power supplies (SMPS), which are working in two-quadrant (2Q bi-directional) operation [1]-[3]. Although, there are now a variety of schemes of DC/DC bidirectional converters, the disadvantage of these solutions is high complexity, or lack of versatility, which is associated with limited utilization of mentioned topologies. The main reason for this are specific requirements for their properties, particularly possibility of change of electrical values as wide as possible. Another disadvantage of existing solutions in terms of universal utilization is relatively high material costs.

Nowadays, the existing solutions of bidirectional converters can be divided as follows: The first group includes cascade DC/DC converters in buck-boost topology, second group are non-isolated half-bridge topologies, in another group the multi-tank non-isolated Cuk and Sepic topologies are presented and last group involves so-called split topologies, using pi-filters at the input and output of converter. The mentioned drawback in the comparison with proposed solution is considerably higher number of components in the system resulting in higher complexity of topology, lack of versatility and insufficient dynamical range of input and output parameters

### 2. Bidirectional step-up/step-down converter with MCC

The main circuit of proposed converter, based on boost DC-DC converter [4]-[6], is composed of three main parts (Fig. 1). The first is given by primary capacitive filter together with primary transistor T1. Second part consists of the most important part of converter – bifilar wound coil, whose windings are connected in order to create auto-transformer with common ground on the primary and secondary side. If target application requires total galvanic isolation between primary and secondary side, it is possible to realize the proposed converter as an isolated bidirectional converter. This approach can also be done by simple modification of the main circuit with the use of auxiliary switch. The last, third part of the proposed converter is composed of secondary transistor T2, of a filter and of load/appliance.

It can be seen from Fig. 1 that the primary as well as secondary part of converter have in principle the same functionality. Based on this property both parts can behave as input or output of the converter (the secondary side is dissymmetrical to the primary side), and, therefore, the energy transfer from source to load and vice versa can be simply and effectively realized. Simultaneously the modification of the electrical variables magnitudes (increase or decrease) can be done in a wide regulation range. Based on the operating conditions, the converter functionality is held in the first- or third quadrant of operating characteristic.

The main advantages compared to other solution of bidirectional DC/DC converters are:

- extra-wide regulation range of electrical variables at given output (step-up/step-down)

\* Michal Frivaldsky<sup>1</sup>, Branislav Dobrucky<sup>1</sup>, Giacomo Scelba<sup>2</sup>, Pavol Spanik<sup>1</sup>, Peter Drgona<sup>1</sup>

<sup>1</sup> Department of Mechatronics and electronics, University of Zilina, Slovakia, E-mail: michal.frivaldsky@fel.uniza.sk

<sup>2</sup> Dipartimento di ingegneria, Università degli studi di Catania, Italy

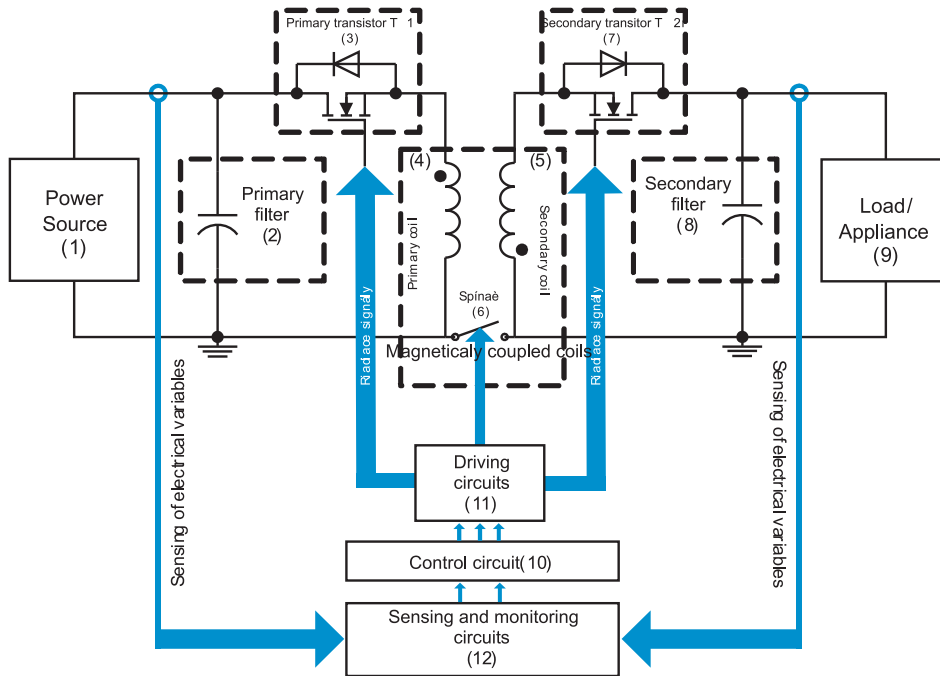

Fig. 1 Block scheme of proposed bidirectional DC-DC converter with MCC [7]

- low complexity of the main circuit within achievement of high universality
- possibility of isolated and non-isolated version

**The analysis of proposed converter**

The proposed converter, whose principal schematic is shown in Fig. 1 is classified as DC-DC converter. The following analysis is oriented on the determination of state space variables and on the investigation of voltage-transfer characteristic in both direct and recuperative mode of operation.

The operation of converter both for directions (energy transfer from source into load) and for recuperative (energy transfer from load into source) mode can be divided into two operating intervals:

- interval  $I(t_0 - t_1)$ : transistor  $T_1$  ( $T_2$ ) closed, transistor  $T_2$  ( $T_1$ ) open;

- interval  $II(t_1 - T)$ : transistor  $T_1$  ( $T_2$ ) open, transistor  $T_2$  ( $T_1$ ) closed.

Fig. 2 shows schematics of the proposed converter, whereby parasitic resistances are considered, and due to fact that their presence is influencing voltage transfer characteristic. This impact is negative and, therefore, must be accepted during state space model setting and its consequent derivation.

The state space model for the proposed converter is derived for the operating condition when the converter operates at direct mode. Here, it must be noted that considering recuperative operating mode the state space will be the same, whereby only one change applies specifically for the input/output arguments in the case of voltages and currents (input will act as output and vice versa).

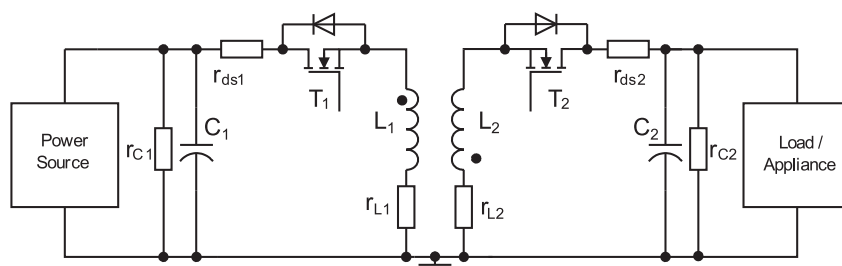

Fig. 2 Block scheme of proposed bidirectional DC-DC converter with MCC

Interval I( $t_0 - t_1$ )

$$\frac{d}{dt} \begin{pmatrix} i_{L1} \\ u_{C2} \end{pmatrix} = \begin{pmatrix} -r_s/L_1 & 0 \\ 0 & -(1/r_2 + 1/R_2)1/C \end{pmatrix} \begin{pmatrix} i_{L1} \\ u_{C2} \end{pmatrix} + \begin{pmatrix} 1/L_1 & 0 \\ 0 & 0 \end{pmatrix} \begin{pmatrix} u_1 \\ 0 \end{pmatrix}, \quad (1)$$

where:

- $i_{L1}$  is the current in the primary side
- $u_{C2}$  is output capacitor voltage
- $r_s$  is the sum of series parasitic resistances
- $r_2$  is the parallel parasitic resistances
- $L_1$  is value of primary inductance
- $U_1$  is input voltage
- $R_2$  is load resistance

Interval II( $t_1 - T$ )

$$\frac{d}{dt} \begin{pmatrix} i_{L2} \\ u_{C2} \end{pmatrix} = \begin{pmatrix} -r_s/L_2 & -1/L_2 \\ 1/C_2 & -(1/r_2 + 1/R_2)1/C \end{pmatrix} \begin{pmatrix} i_{L2} \\ u_{C2} \end{pmatrix} + \begin{pmatrix} 1/L_2 & 0 \\ 0 & 0 \end{pmatrix} \begin{pmatrix} 0 \\ 0 \end{pmatrix} \quad (2)$$

The voltage transfer characteristic can be derived from the comparison of ripple current during the first and second interval. The analysis outgoes from the equation of inductor's voltage:

$$u_L = L \cdot \frac{di_L}{dt} \quad (3)$$

After linearization, the next formula is valid for ripple current:

$$\Delta I_L = \frac{U \cdot D \cdot T}{L}, \quad (4)$$

where:

- $D$  is duty cycle,
- $T$  is switching period of converter.

Comparing the value of ripple current during interval when transistor T1 is closed with the ripple current from the interval when transistor T1 is open leads to:

$$\frac{U_1 \cdot D \cdot T}{L_1} = \frac{U_2 \cdot (1 - D) \cdot T}{L_2}. \quad (5)$$

When  $L_1 = L_2$ , thus  $N_1 = N_2$ , where  $N_1$  and  $N_2$  are numbers of primary or secondary turns and all parasitic resistances are neglected, then the next equation for approximate computation of voltage transfer function can be written:

$$\frac{U_2}{U_1} = \frac{D}{(1 - D)}. \quad (6)$$

Figure 3 shows graphical interpretation of voltage transfer characteristic with ideal waveform (without parasitic ones), and voltage transfer waveform when parasitic resistances are being considered.

### 3. Simulation investigations of proposed converter's properties

In this chapter we would like to investigate the voltage transfer functions of the proposed converter based on parametrical simulations from OrCAD/Pspice. Based on this, and after comparisons with theoretical assumptions it is possible to demonstrate existing deviations in voltage transfer function.

Next figure shows voltage transfer function of the proposed converter whose input/output parameters are as follows:

- $U_{IN} = 24 \text{ V}$ ,  $f_{SW} = 50 \text{ kHz}$ ,  $L_1 = L_2 = 300 \text{ }\mu\text{H}$  ( $N_1 = N_2$ ),
- $U_{OUT} = \text{var}$ ,  $I_{OUT} = \text{var}$ ,  $P_{OUT} = \text{max. } 25 \text{ W}$ ,
- load resistance  $R_2 = 48 \text{ }\Omega$ ,
- Parasitics  $r_s = 0.24, 0.48, 0.96 \text{ and } 1.44 \text{ }\Omega$ :

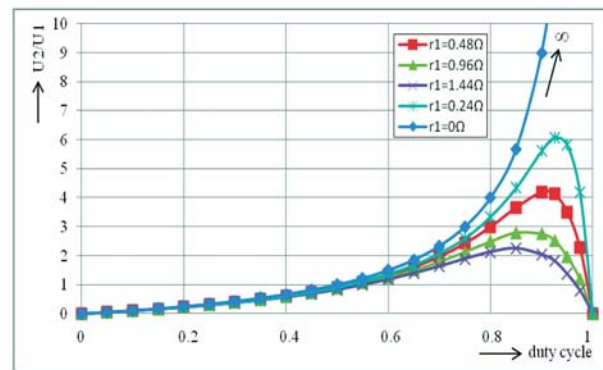

Fig. 3 Voltage transfer function of proposed converter at 100% power loading and various parasitic resistances from 0 to 1.44 Ohm

Load 100, 200 and 20%,  $R = 48, 24$  and  $240 \text{ }\Omega$ :

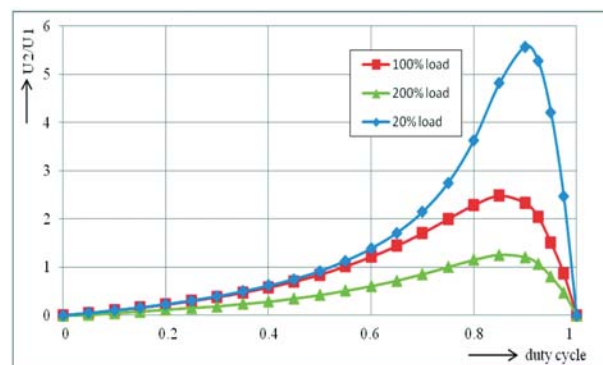

Fig. 4 Voltage transfer function of proposed converter at 20, 100 and 200 % of power loading

It is evident from Figs. 3 and 4 that

- idealized relation of voltage transfer ration  $U_2/U_1$  on duty cycle  $D$  (i.e. =  $D/1 - D$ ) is not valid for entire range of duty cycle ( $\in (0;1)$ );
- consequently, voltage transfer characteristic is not monotonic one but it has a local extreme at which derivative of the transfer is changing; it is a critical point of characteristic;
- control system used should be acting just in 'secure' range from 0 to a critical value of duty cycle  $D_{crit}$ , otherwise it must have a variable structure.

**4. Experimental verification of bidirectional step-up/step-down converter with MCC**

The experimental set/up was built (Fig. 5) with parameters:  $U_{IN} = 24 \text{ V}$ ,  $f_{SW} = 50 \text{ kHz}$ ,  $L_1 = L_2 = 300 \text{ }\mu\text{H}$  ( $N_1 = N_2$ ),  $C$  load resistance  $R_2 = 48, 24, 240 \text{ }\Omega$ ,  $P_{OUT} = \text{var. } 25 \text{ W}$  as maximum, depending on load resistance.

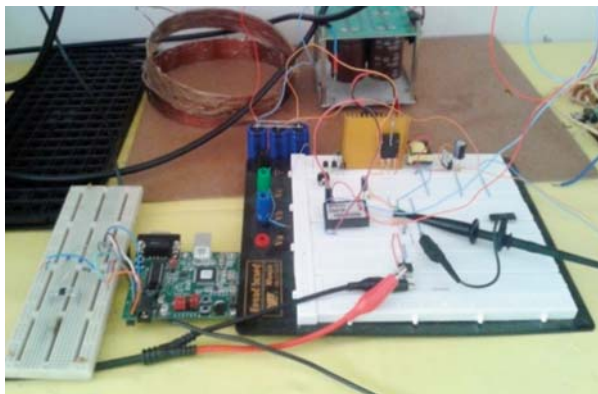

Fig. 5 Experimental set-up of proposed bidirectional step-up/step-down converter

There are results carried-out by measurement on experimental set-up of the converter at 20-, 100-, and 200 % of the load under resistive loading.

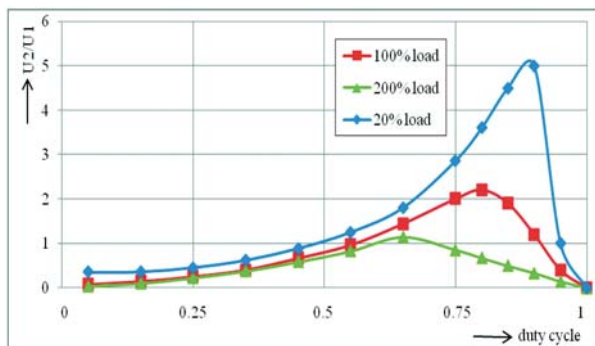

Fig. 6 Experimental voltage transfer functions of proposed converter at 20-200 % load

Output power can be calculated from the carried-out transfer characteristics in Fig. 6

$$P_{OUT} = \frac{U_2^2}{R_2} : P_{48\Omega} = \frac{(2 \cdot 24)^2}{48} = \frac{4 \cdot 24^2}{2 \cdot 24} = 48 \text{ W}$$

at  $D = 0.75$ ;

$$P_{48\Omega} = \frac{(1 \cdot 24)^2}{48} = \frac{14 \cdot 24^2}{2 \cdot 24} = 12 \text{ W}$$

at duty cycle  $D = 0.50$ ;

$$P_{48\Omega} = \frac{(1.41 \cdot 24)^2}{48} = \frac{2 \cdot 24^2}{2 \cdot 24} = 24 \text{ W}$$

at duty cycle  $D = 0.625$ ;

It is possible to calculate the requested power (24 W) also under 24  $\Omega$  load resistance

$$P_{24\Omega} = \frac{(1 \cdot 24)^2}{24} = \frac{1 \cdot 24^2}{1 \cdot 24} = 24 \text{ W}$$

at duty cycle  $D = 0.65$ .

So, for a fair design of the converter elements it is necessary to determine at what output voltage we want the requested power. Possible improvements of operation and efficiency of the converter are to be reached by works [8]-[10].

**5. Conclusion**

The bidirectional step-up/step-down converter was presented in the paper. Simulation experiment results worked-out using OrCAD/PSpice programming environment showed that voltage transfer characteristics feature two parts: the first one with positive derivative part, and the second one with negative derivative part. Maximal output voltage doesn't depend only on a duty cycle of electronic switches but also on the parasitic parameter values of the converter circuit elements. The experimental set/up measurements verified results of simulation and theoretical assumptions.

Presented solution of bidirectional converters based on buck-boost DC/DC topology consists of substantial lesser components than classical cascade DC/DC converters or non-isolated half-bridge topologies, and features: an extremely wideregulation range of output voltage, low complexity of main circuit within achievement of high universality, and possibility of isolated and non-isolated versions. Such a converter system can be utilized as a part of power semiconductor system in traction, automotive, or industrial applications like renewable energy sources.

As future work we suppose the investigation of transient behavior -, efficiency analysis- and control system design of that type of bidirectional step-up/step-down converter.

**Acknowledgement**

The authors wish to thank for the financial support to Slovak Research and Development Agency project No. APVV-0138-10 and R&D operational program Centre of excellence of power

electronics systems and materials for their components No. OPVaV-2008/2.1/01-SORO, ITMS 26220120046 funded by European regional development fund (ERDF).

**References**

- [1] LUO, F.L., YE, H.: *Power Electronics - Advanced Conversion Technologies*. CRC Press: Boca Raton, 2010, ISBN 978-1-4200-9429-9.
- [2] SZYCHTA, E.: *Multi-Resonant ZVS Converter of DC/DC Voltage Type (in Polish)*. Monograph, Oficyna Wydawnicza Uniwersytetu Zielonogorskiego, 2006.
- [3] BERES, T., DUDRIK, J., EOTVOS E.: Bidirectional Step-up/step-down DC-DC Converter for Hybrid Battery (in Slovak). *EE-Journal for Electrical Engineering and Electro-Energetics*, vol. 17, No. 1, 2011, pp. 31-32, ISSN 1335-2547.
- [4] HIMMELSTOSS, F. A., VOTZI, H. L.: Combined Forward-Flyback-Converter with Only Two Diodes - Function and Modelling. *Communications - Scientific Letters of the University of Zilina ZU*, pp. 6-12, 2a/2011.
- [5] LUFT, M., SZYCHTA, E., SZYCHTA, L.: *Method of Designing ZVS Boost Converter*, 13<sup>th</sup> Power Electronics and Motion Control Conference - EPE-PEMC, Poznan, pp. 463-467, 2008.
- [6] DOBRUCKY, B., HRABOVEC, L., POPRENDÁ, J.: *Power Supply of Increased Exciting Voltage of Static Exciter for Traction Generator GPA-600 (in Slovak)*, Research Report No. V-0767/88, EVPU a.s., Nova Dubnica, March 1988.
- [7] FRIVALDSKY, M., DOBRUCKY, B., SPANIK, P.: *Bidirectional Step-up/step-down DC-DC Converter with Magnetically Coupled Coils (in Slovak)*, Application on Industrial Template PUV No. N/A, submitted: Apr. 8, 2013.
- [8] DUDRIK, J., TRIP, N. D.: Soft-Switching PS-PWM DC-DC Converter for Full-load Range Applications, *IEEE Transactions on Industrial Electronics*, vol. 57, No. 8, pp. 2807-2814, 2010.
- [9] DOBRUCKY, B., SPANIK, P., SUL, R.: Improvement of Power Electronic Structure Characteristics Using SiC Technology - An Overview. *Communications - Scientific Letters of ZU*, No.1, pp. 34-38, 2006
- [10] SPANIK, P., DOBRUCKY, B., FRIVALDSKY, M., DRGONA, P.: Experimental Analysis of Commutation Process of Power Semiconductor Transistor Structures, *Acta Technica CSAV*, vol. 52, No. 4, 2007, pp. 399-413, ISSN 0001-7043.