

Pavel Zaskalicky – Ludek Schreier *

USING FOURIER ANALYSIS FOR TORQUE ESTIMATION OF TWO-PHASE INDUCTION MOTOR SUPPLIED BY HALF-BRIDGE INVERTER WITH PWM CONTROL

The paper deals with the steady state analysis of electromagnetic torque ripples of a two-phase induction machine, which is supplied by a half-bridge connected inverter with IGBT transistors. The inverter output voltage is controlled by a PWM of the input DC voltage. The complex Fourier series analysis of the inverter output voltage was made to obtain the spectrum of voltage-supply harmonics. Particular voltage harmonics were applied to the two-phase induction machine numerical model so that the electromagnetic torque waveforms for various operation conditions were obtained.

Keywords: Two-phase inverter, Induction machine, Torque ripple, Fourier series, Mathematical model.

1. Introduction

Electrical low-power drives (around 100W) with a single-phase induction motors, used in different appliances and industrial devices are at present increasingly replaced by two-phase motors.

The characteristics of two-phase motors do not substantially differ from those of three-phase motors. Their advantage is simpler winding, which is of great importance for automated production. The two-phase motors are manufactured as either cage induction motors or permanent magnet synchronous motors. They are used e.g. as drives of pumps in washing machines and dishwashers and as drives of circulating pumps for central heating. A permanent magnet is water and lye resistant, which makes it possible to produce an absolutely waterproof pump. The two-phase voltage is generated by converters supplied from a single-phase network.

The use of a two-phase motor has several advantages. The stator winding has the simplest form. Three shifted coil windings constitute one phase winding. The stator windings can be configured in either a serial or parallel two-phase system.

Both windings are usually identical. The windings which form one phase are connected in such a way as to induce opposite magnetic polarity.

Figure 1 illustrates a prototype of a two-phase induction motor.

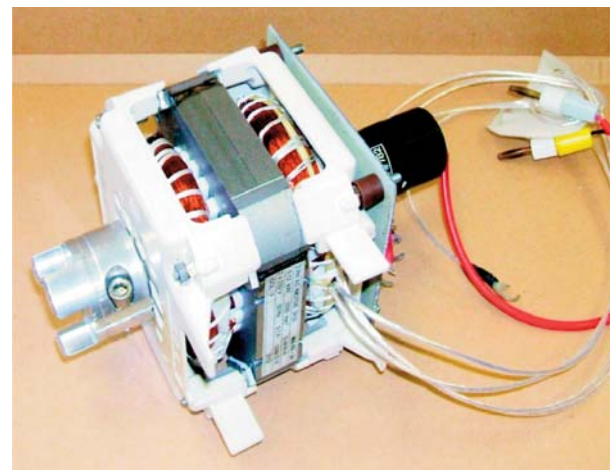

Fig. 1 Prototype of a two-phase induction motor

2. Mathematical model of the supply converter

The analysis of the inverter operation at steady state was made under the following simplifying conditions:

- The power switch can handle unlimited currents and can block unlimited voltages.
- The voltage drop across the switch and leakage current through switch are zero.

* Pavel Zaskalicky¹, Ludek Schreier²

¹ Department of Electrical Engineering and Mechatronics, Faculty of Electrical Engineering and Informatics, Technical University of Kosice, Slovakia, E-mail: pavel.zaskalicky@tuke.sk

² Department of Electrical Engineering and Electrophysics, Institute of Thermomechanics AS CR, v.v.i, Praha, Czech Republic

- The switch is turned on and off with no rise and fall times.
- The sufficient value of capacitance of the input voltage capacitor divider makes it possible to consider a constant DC voltage of the converter input.

These assumptions help us simply analyse a power circuit and set up a mathematical model of the inverter at steady state. Figure 2 shows a two-phase converter circuit configuration.

The output voltage level of the inverter can be controlled by reducing the DC source voltage. Another way of the voltage control is notching, when the transistors in the inverter circuit are turned on and off, which results in producing zero periods of equal lengths.

The improvement to the notched waveform means that the interval when the transistors are switched on is the longest at the peak of the wave. This way of control is known as the pulse width modulation (PWM).

It can be observed that the length of each pulse corresponds approximately to the area under the sine-wave between the adjacent mid-points when the transistors are switched off. The pulse width modulated wave has much lower harmonic content than waveform modulated in a different way

If the desired reference voltage is sine wave, two parameters define the control [1]:

- *Coefficient of the modulation m* - equal to the ratio of the modulation and reference frequency.
- *Voltage control coefficient r* - equal to the ratio of the desired voltage amplitude and the DC supply voltage.

Mostly, the synchronous modulation is used. In synchronous modulation, the modulation frequency is an integer multiple of the frequency of the reference sine wave.

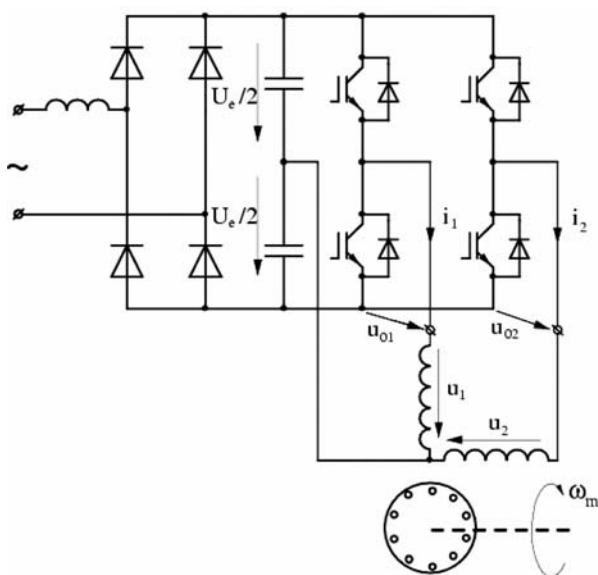

Fig. 2 Supply converter circuit layout

Generally, to control the inverter, a numerical control device is used. The turn on (α) and turn off (β) angles are calculated on the basis of the reference sine wave. That means the reference sine wave is replaced by discrete voltage impulses. If the coefficient of modulation m is sufficiently great, the difference between real values and discrete values is negligible.

The inverter output voltage of the first branch can be mathematically expressed as a complex Fourier series in the form [2], [3] and [4]:

$$u_{01} = U_e \sum_{k=-\infty}^{\infty} \sum_{n=1}^m c_{01n} e^{jk\theta} \quad (1)$$

with Fourier coefficients:

$$\begin{cases} c_{01n} = \frac{1}{j2k\pi} (e^{-jk\alpha_{01n}} - e^{-jk\beta_{01n}}) & \text{for } k \neq 0 \\ c_{01n} = \frac{\beta_{01n} - \alpha_{01n}}{2\pi} & \text{for } k = 0 \end{cases}$$

Similarly for the second branch:

$$u_{02} = U_e \sum_{k=-\infty}^{\infty} \sum_{n=1}^m c_{02n} e^{jk\theta} \quad (2)$$

with Fourier coefficients:

$$\begin{cases} c_{02n} = \frac{1}{j2k\pi} (e^{-jk\alpha_{02n}} - e^{-jk\beta_{02n}}) & \text{for } k \neq 0 \\ c_{02n} = \frac{\beta_{02n} - \alpha_{02n}}{2\pi} & \text{for } k = 0 \end{cases}$$

Calculated waveforms of the branch voltages are unipolar. Based on the voltage equation, the phase voltages are given as a difference between the branch voltages and the voltage of the capacitor divider:

$$\begin{aligned} u_1 &= u_{01} - \frac{U_e}{2} = U_e \sum_{k=-\infty}^{\infty} \sum_{n=1}^m c_{01n} e^{jk\theta} - \frac{U_e}{2}; \\ u_2 &= u_{02} - \frac{U_e}{2} = U_e \sum_{k=-\infty}^{\infty} \sum_{n=1}^m c_{02n} e^{jk\theta} - \frac{U_e}{2} \end{aligned} \quad (3)$$

In Fig. 3, the phase voltage waveforms are shown. The voltages are bi-polar with amplitude equal to half of DC input voltage [5].

3. Harmonic analysis of the supply voltages

On the basis of Fourier series formulas of the supply voltages, a harmonic analysis of the supply waveforms can be made.

The amplitude of each harmonic is calculated on the basis of equations (3). The amplitude of k th harmonic is given:

$$A_k = \sum_{n=1}^m (c_{01n}^k + c_{01n}^{-k}) \quad (4)$$

Figure 4 depicts a harmonic analysis of the PWM output voltage for frequency of and modulation frequency of .

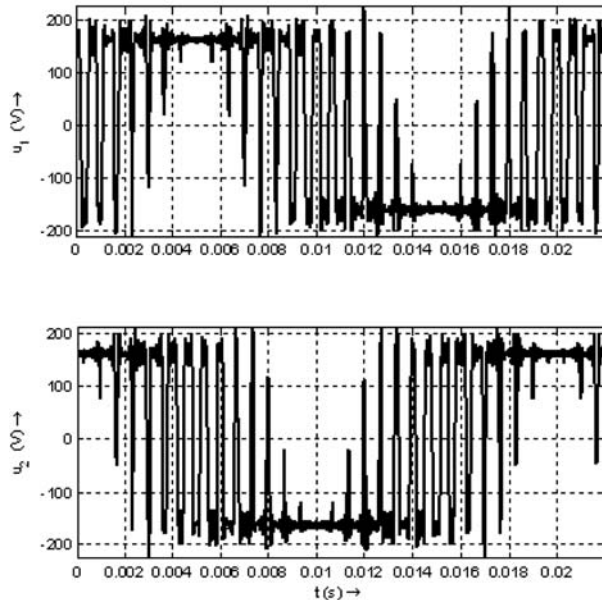

Fig. 3 Waveforms of the phase voltages

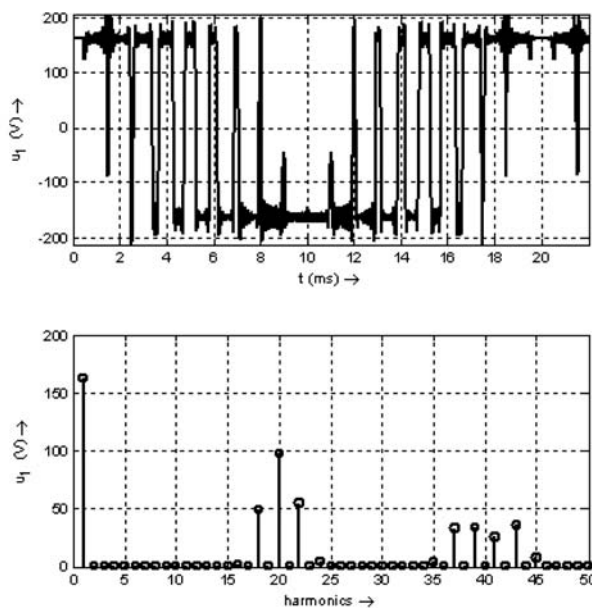

Fig. 4 Harmonic analysis

In Table 1, the parameters of the main harmonics are given.

4. Mathematical model of a two-phase induction motor

A mathematical model of a two-phase induction machine can be easily derived from the equations of a single-phase motor with an auxiliary winding [6].

The main harmonics

Table 1

Harmonic	Amplitude	1st phase	2nd phase
1	162.3 V	cos	sin
18	48.4 V	-cos	cos
20	97.8 V	cos	cos
22	54.2 V	-cos	cos
37	32.6 V	cos	sin
39	33.3 V	-cos	sin
41	25.7 V	-cos	-sin
43	25.4 V	-cos	-sin

In the case of a two-phase machine, both the stator windings are mutually rotated by 90 electric degrees and have the same number of turns. On condition that the real axis of the system of coordinates coincides with the axis of the winding 1, it can be written as

$$u_1 = R_S i_1 + L_S \frac{di_1}{dt} + L_h \frac{di_{R\lambda\alpha}}{dt} \quad (5)$$

The axis of the winding 2 coincides with the imaginary axis and is described by the equation

$$u_2 = R_S i_2 + L_S \frac{di_2}{dt} + L_h \frac{di_{R\lambda\beta}}{dt} \quad (6)$$

A cage rotor can be described by equations

$$0 = R_{RS} i_{R\lambda\alpha} + L_{RS} \frac{di_{R\lambda\alpha}}{dt} + p\omega_m (L_{RS} i_{R\lambda\beta} + L_h i_2) \quad (7)$$

$$0 = R_{RS} i_{R\lambda\beta} + L_{RS} \frac{di_{R\lambda\beta}}{dt} - p\omega_m (L_{RS} i_{R\lambda\alpha} + L_h i_1) \quad (8)$$

Torque T in the air gap is given by the equation

$$T = pL_h (i_{R\lambda\beta} i_1 - i_{R\lambda\alpha} i_2) \quad (9)$$

Equations (5) to (9) are valid under assumptions currently considered in the theory of electrical machines.

Particular symbols represent:

R_S stator resistance,

R_{RS} rotor resistance,

L_S stator inductance,

L_{RS} rotor inductance,

L_h main inductance,

p number of pole pairs,

u_1 and u_2 stator voltages

$i_{R\lambda\alpha}$ and $i_{R\lambda\beta}$ real imaginary parts of the spatial vector of rotor currents and

ω_m mechanical speed.

Subscript S at rotor parameters means that rotor resistance and inductance were referred to the effective number of stator turns. Subscript λ at the real α and imaginary β components of rotor

currents means that these quantities were referred to the effective number of stator turns and transformed to the stator coordinate system.

The equations of a two-phase induction motor were supplemented with the equation of motion

$$\frac{d\omega_m}{dt} = \frac{1}{J}(T - T_l) \quad (10)$$

where J is the moment of inertia and T_l is the load torque. Based on equations (5) and (9), a numerical model of a two-phase induction machine was set up. This model makes it possible to simulate the behaviour of a considered machine in steady and transient states.

5. Examples of simulations

The following five figures show waveforms of the stator currents, rotor currents, magnetizing current, torque and speed in steady state. The parameters of the prototype of the two-pole induction motor from Fig. 1 were used in the model. The nominal values of the motor are: power 40 W; supply voltages 2×115 V, 50 Hz; current 0.26 A; rotating speed 2640 rpm; torque 0.145 Nm.

The motor has the parameters:

- $R_S = 31 \Omega$;
- $R_{RS} = 51 \Omega$;
- $L_{lh} = 1.181$ H;
- $L_S = L_{RS} = 1.331$ H;
- $J = 0.000141$ kgm/s²;

The value of the load torque was $T_l = 0$ and the moment of inertia were chosen in such a way so that the course of speed was not substantially influenced by torque ripples. The simulated voltages u_1 and u_2 were approximated by all harmonics stated in Table 1. The waveforms u_1 and u_2 are shown in Fig. 5. The simulated waveforms of currents i_1 and i_2 and the components of rotor currents $i_{R\alpha}$ and $i_{R\beta}$ are in Figs. 6 and 7.

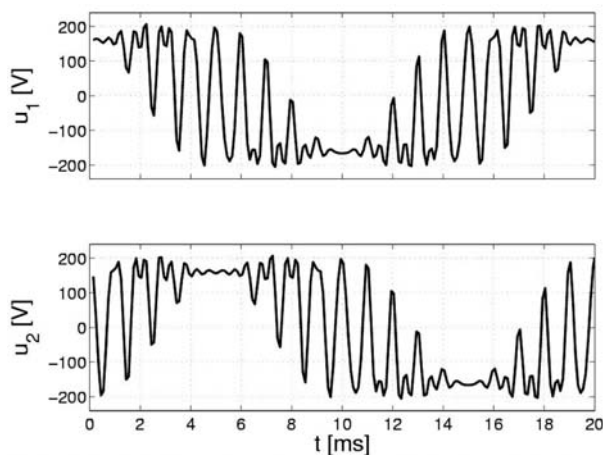

Fig. 5 Waveforms of supply voltages

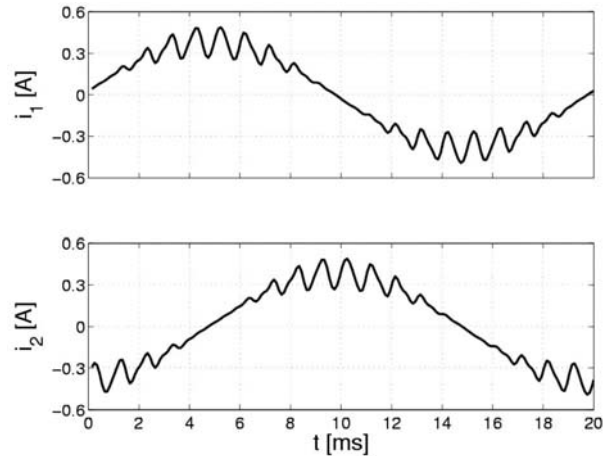

Fig. 6 Stator currents

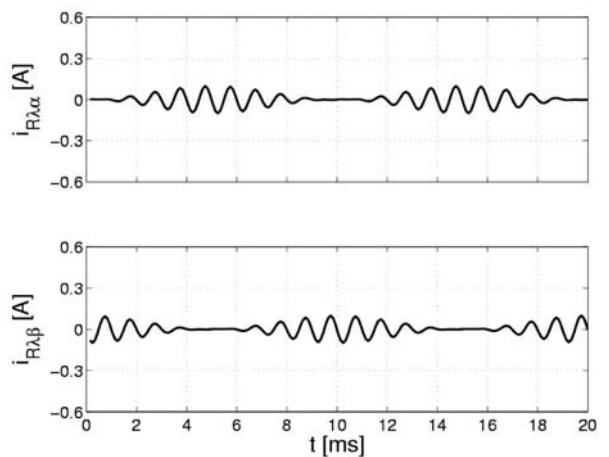

Fig. 7 Rotor current components

It is clear from Fig. 6 that phase-shift between currents i_1 and i_2 is ninety degrees and they have the same value of magnitudes. Thus, no negative-sequence component arises. Also, no pulsations of two-multiply of basic frequency (50 Hz) are presented.

The distortion of the currents due to the time harmonics of the voltage is apparent. The flux in the yoke and in the air gap is proportional to the magnetizing current. The real and imaginary components of the magnetizing current are defined as:

$$i_{\mu\alpha} = i_1 + i_{R\alpha} \quad (11)$$

$$i_{\mu\beta} = i_2 + i_{R\beta} \quad (12)$$

The waveforms of the components of the magnetizing current are in Fig. 8. The distortion of the flux in the yoke due to the time harmonics in stator voltages is small in comparison with the distortions of the currents.

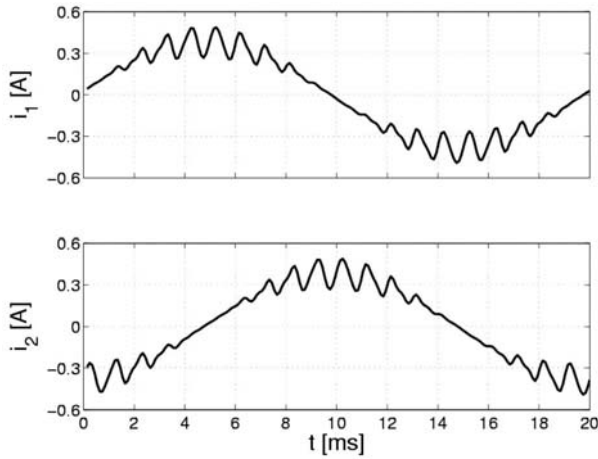

Fig. 6 Stator currents

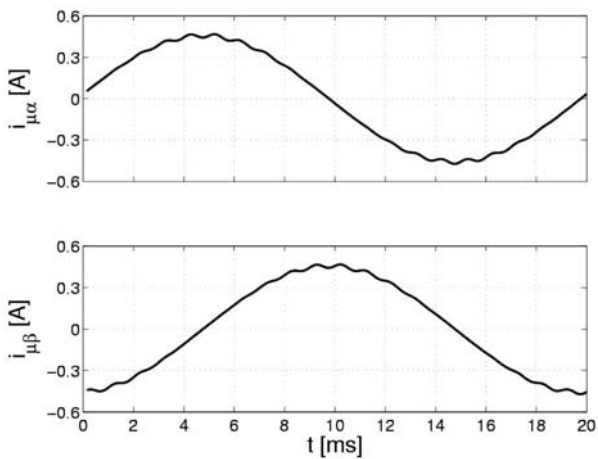

Fig. 8 Components of magnetising current

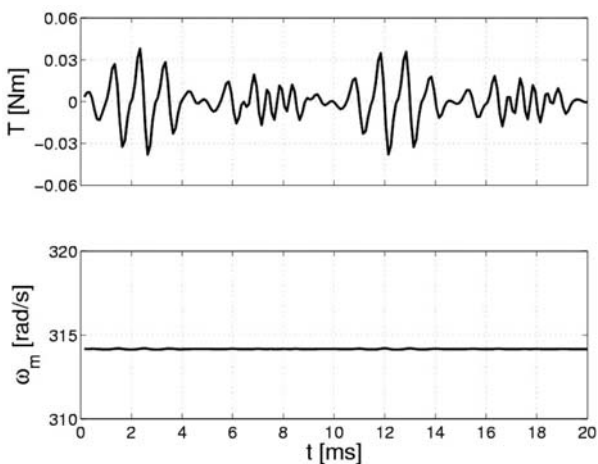

Fig. 9 Torque and speed

It is apparent that the magnitude of space vector of fundamental harmonic of the flux along the air gap is constant in steady state. The torque in no-load operation is shown in Fig. 9.

To estimate the influence of higher harmonics of currents the equal quantities as in Figs. 5 to 9 were simulated in case that only the fundamental wave and three higher harmonics of the lowest order in Table 1 were considered. The voltages u_1 and u_2 are in Fig. 10. The approximation of stator voltages is worse than in the case shown in Fig. 5. The simulated stator currents are shown in Fig. 11. Figure 12 shows the torque and speed. The differences between the quantities in Figs. 6 and 11 and between the quantities in Figs. 9 and 12 are practically negligible. The same can be stated about the waveforms of the components of the rotor and magnetizing current, therefore, they are not presented.

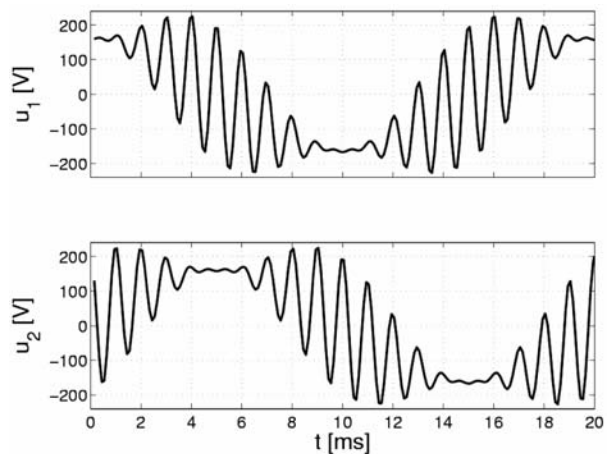

Fig. 10 Waveforms of supply voltages, the 18-th, 20-th and 22-nd harmonics considered

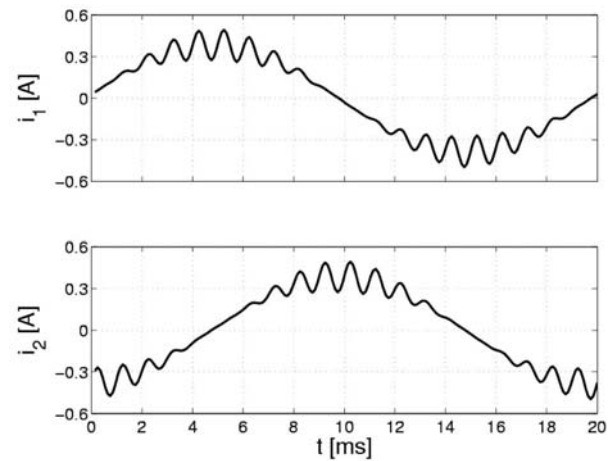

Fig. 11 Components of magnetising current the 18-th, 20-th and 22-nd harmonics considered

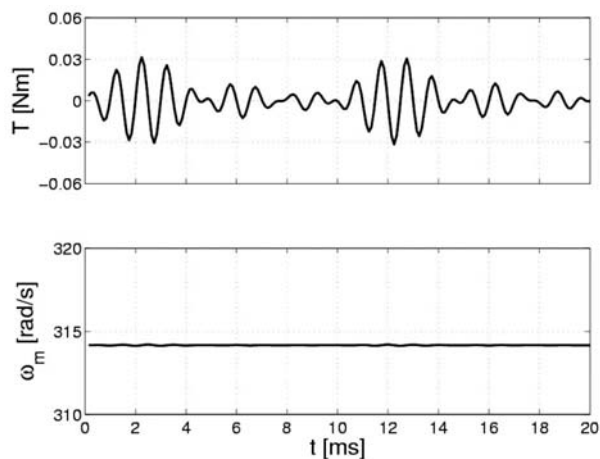

Fig. 12 Torque and speed
the 18-th, 20-th and 22-nd harmonics considered

6. Conclusions

At it is apparent from the waveforms of stator currents and torque, the advantage of a two-phase motor compared with a single-phase motor is that the currents and flux of the fundamental spatial wave give rise only to the positive-sequence component while in a single-phase machine also the negative-sequence component arises.

In case of the considered modulation frequency, it is quite sufficient to consider, besides the fundamental harmonic of the stator voltages, only three waves of the lowest order. The influence of other harmonics on the waveforms of the currents of the flux and torque is very low and can be, therefore, neglected.

Acknowledgment

The financial support of the Slovak Research and Development Agency under the contract No: APVV-0138-10 and the Institutional support RVO: 61388998 are acknowledged.

References

- [1] TAKEUCHI, T. J.: *Theory of SCR Circuit and Application to Motor Control*; Electrical Engineering College Press, Tokyo, 1968.
- [2] ZASKALICKY, P., DOBRUCKY, B.: *Complex Fourier-series Mathematical Model of a Three-phase Inverter with Improved PWM Output Voltage Control*; *Elektronika ir Elektrotechnika*, No. 7 (123), pp. 65–68, 2012, KTU, Kaunas.
- [3] ZASKALICKA, M., ZASKALICKY, P., BENOVA, M., MAHMUD A. R., DOBRUCKY, B.: *Analysis of Complex Time Function of Converter Output Quantities Using Complex Fourier Transform/series*; *Communications - Scientific letters of the University of Zilina*, vol. 12, No. 1, pp. 23–30, 2010, Zilina.
- [4] ZASKALICKY, P., KANUCH, J.: *Complex Fourier Series Mathematical Model of a Single Phase Inverter with PWM of a Output Voltage*; SMC'2009, XIII Intern. Conference System Modelling and Control, October 12–14, 2009, Zakopane.
- [5] DOBRUCKY, B., BENOVA, M., SPANIK, P.: *Using Complex Conjugated Magnitudes- and Orthogonal Park-Clarke Transformation Methods of DC/AC/AC Frequency Converter*, *Elektronika ir Elektrotechnika T 170*, No. 5(93), 2009, pp. 29–33, 2009.
- [6] SCHREIER, L., BENDL, J., CHOMAT, M.: *Contribution to Analysis of Steady-State Operation of Single Phase Induction Motors*, Intern. Conference on Low Voltage Electric Machines LVEM 2007, pp. 88–91, November 2007, Brno.