

Patricia Duratna – Abdelhamid Bouchair – Jan Bujnak *

ANALYSIS OF THE BEHAVIOUR OF STEEL-CONCRETE COMPOSITE TRUSS

The design specifications of composite truss, included in the American standard (ASCE), are not covered in the European standards (Eurocodes). In this study, to investigate the behaviour of the composite trusses, a finite element model (FEM) is developed using the software CAST3M. The influence of various parameters, such as the diameter of the shear connectors, the degree of connection, the top chord section and the material characteristics on the behaviour of the composite truss and the shear connectors are analyzed. The model shows that the shear connection in the steel-concrete composite truss reduces its deflection by approximately 50 % in comparison with the steel truss. The significant influence of the top chord section on the shear forces in the shear connectors was observed.

Keywords: FEM Analysis, Top Chord Section, Shear Connectors, Shear Force.

1. Introduction

Composite steel-concrete construction is one of the most economical systems for building and bridge floors, especially for greater spans. To mobilize the efficiency of concrete in compression and steel in tension it is necessary to prevent the relative slip between the concrete and the steel element using the shear connectors. Different types of shear connectors are used nowadays. This concerns the welded headed studs, the Hilti brackets and the welded perforated shear connectors [1] [2]. In some situations, such as with precast concrete slab or to develop composite action in non-composite structures, shear connection is developed using bolts [3] [4].

Composite systems give the possibility to get spans up to 20 m and the composite trusses are appropriate to meet the requirements for building height limitation, the need to run complex electrical, heating, ventilating, and communication systems and the even greater spans (30 m), which allows a better use of internal space without restricting columns.

Since the mid of 1960's, many investigations have been made in testing composite trusses mainly in USA and Canada, summarized in references [1] and [5]. The experimental results led to design recommendations and specification of the American Society of Civil Engineers (ASCE) [6].

In Eurocode EN 1994-2: 6.6.2.3 [7], there is no particular recommendation for the design of composite truss, except the formulas for the local effect of a concentrated longitudinal force and the distribution of the longitudinal shear force into local shear flow

between steel section and concrete slab. In fact, the longitudinal forces are introduced into the concrete slab only locally at points of the increase of the axial force in the chord, i. e. where the web members are connected to the compressed chord (panel points).

In this study the influence of the degree of connection, represented by the connector diameter, the influence of the top chord section and the material characteristics of steel and concrete are analyzed pondering over the stiffness and the resistance of the beams and the shear forces in the connectors. The analysis is based on the finite element modeling.

2. FEM Model

For the analysis of the composite truss the software CAST3M is used. The geometry of the truss (Fig. 1) is chosen from the references [1] [2]. The top chord of the steel truss is designed as $\frac{1}{2}$ IPE 220, the bottom chord is a rectangular hollow section RHS $60 \times 60 \times 4$ and the web members are from RHS $50 \times 50 \times 3$. The top chord of the truss is connected to the concrete slab (1500×80 mm) with headed studs connectors ($\Phi = 19$ mm). All the components of the composite beam are modeled using beam elements with appropriate cross section. The web member elements are considered pinned but the chords are continuous.

The analysis was performed using the characteristic values of material properties. Simplified stress-strain diagrams of steel (S355) and concrete (C25/30) are shown in Fig. 2. The non-linear behaviour of the shear connection was modelled using beam elements uniformly distributed with a regular spacing equal to 100 mm along

* Patricia Duratna^{1,2}, Abdelhamid Bouchair¹, Jan Bujnak²

¹ LaMI, Polytech, Clermont Universite, Universite Blaise Pascal, Clermont-Ferrand, France, E-mail: patricia.duratna@polytech.univ-bpclermont.fr

² Faculty of Civil Engineering, University of Zilina, Slovakia

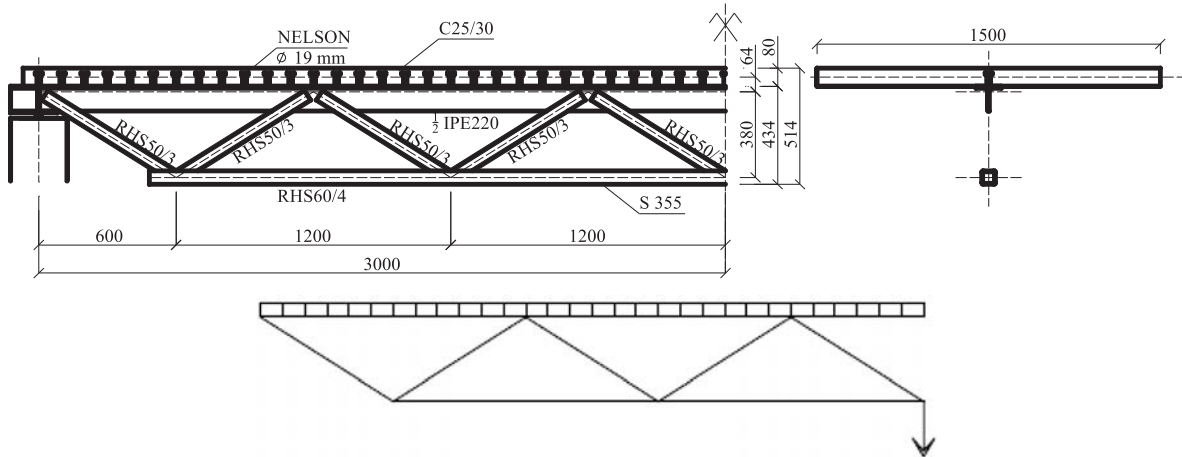

Fig. 1 Geometric characteristics of the composite truss and the FEM model

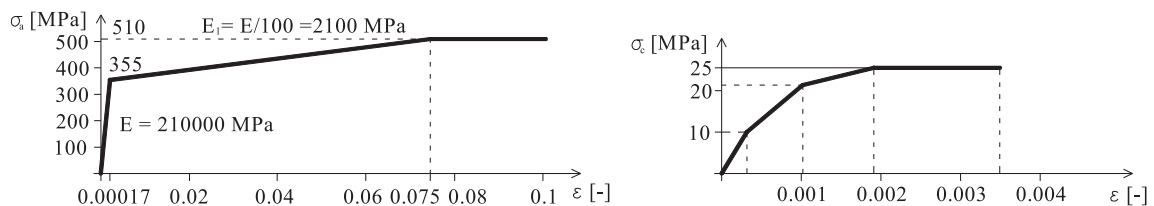

Fig. 2 Stress-strain curves of the steel and the concrete used in the FEM model

the span and located between the neutral axis of the top chord and the concrete slab [8]. In the model, virtual elastic-plastic material is used for the beam element in bending to represent the behaviour of the connection in shear. The uplift effects between the concrete slab and the beam element, prevented by the axial stiffness of the beam element representing the connector, are neglected in the model.

As the results of the push-out test of shear connectors were not available, the following formula of Ollgaard for stud shear capacity [9], based on the results of the push-out tests, was used.

$$P_{max} = 0.336A_d \sqrt{f_{ck} E_{cm}} \quad (1)$$

where A_d is the area of the shank of the stud, f_{ck} is the compressive cylinder strength of the concrete and E_{cm} is the secant modulus of the concrete.

The analytical expression of the evolution of the load - slip ($P_i - s_i$) curve is given by equation (2).

$$P_i = P_{max} (1 - e^{-0.709s_i})^{0.4} \quad (2)$$

Loading of the truss was imposed at the central node of the bottom chord (Fig. 1). For elastic analysis, a load of 10 kN is applied

and for plastic analysis the load is applied with a displacement control with a maximum value equal to 100 mm.

3. Results

In elastic analysis, the influence of the connectors is analyzed considering 360 theoretical values of diameter in the range 0.1 mm to 100 mm. These values represent the progression of the degree of shear connection in the truss from no connection to full connection. Their influence on the stiffness of the composite truss is shown in Fig. 3. It can be observed that the usual diameter of 19 mm is enough to obtain a full connection in the truss. Fig. 3 shows that the composite effect obtained by the shear connector diameter variation can increase even twice the stiffness of the truss with no connection and the truss composite beam with full connection.

The next investigation of the effect of the top chord section on the composite truss, included primarily its area A and the moment of inertia I . The chord varied from 1/2 IPE80 to 1/2 IPE600 (18 different sections). In this analysis a full connection is considered and the distance between the top chord and the bottom chord centroids remains constant. The value of the distance between the centroid of the top chord and that of the whole truss, when the top chord parameters A and I increase, becomes greater in the elastic analysis and decreases in the plastic analysis (Fig. 4). For the top chord

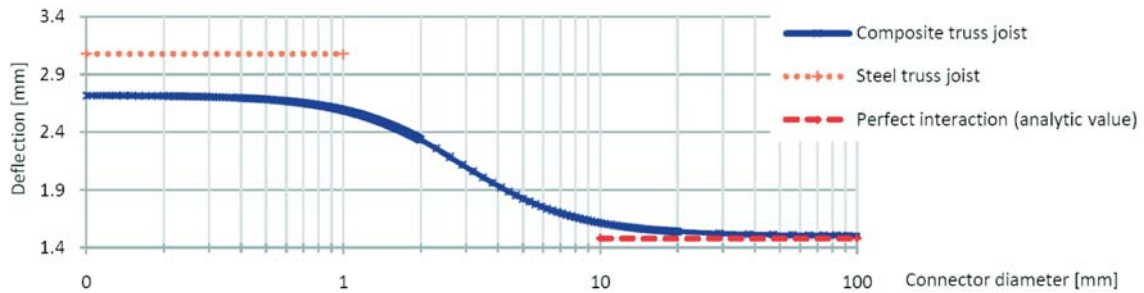

Fig. 3 Influence of the connector diameter on the deflection of the composite truss

section with $A < 6.7 \times 10^{-3} \text{ m}^2$ ($I < 4.6 \times 10^{-5} \text{ m}^4$) this distance and the contribution of the top chord to the resistance of the whole section are greater in plastic analysis than in elastic analysis. For the analyzed truss configuration, the contribution of the top chord on the resistance of the whole section is 7% in elastic analysis and 10% in plastic analysis. Therefore, in accordance with these results, the ASCE [6] neglects the global contribution of the top chord to the resistance of the whole section.

In Fig. 5, it can be seen that the influence of the top chord section on the stiffness of the truss damps down with the increase of the degree of connection for all types of the degrees of connection. This influence is more significant for lower degrees of con-

nections (no connection or partial connection) with small chord sections (lower than $1.5 \times 10^{-3} \text{ m}^2$). However for the real (and full) connection, the top chord section does not influence the stiffness of the composite truss significantly. The curves in Fig. 5 are drawn on the basis of the results of Fig. 3 where the full connection is represented by connector diameter of 50 mm, the real connection represented by the diameter 19 mm and the partial connection by the diameter 3 mm.

The distribution of the shear forces in the connectors along the beams, provided by plastic analysis and for the displacement equal to 100 mm is shown in Fig. 6 for different top chord sections. It can be observed that the plastic deformation of the connectors gives uniform distribution of shear forces along the beam. This

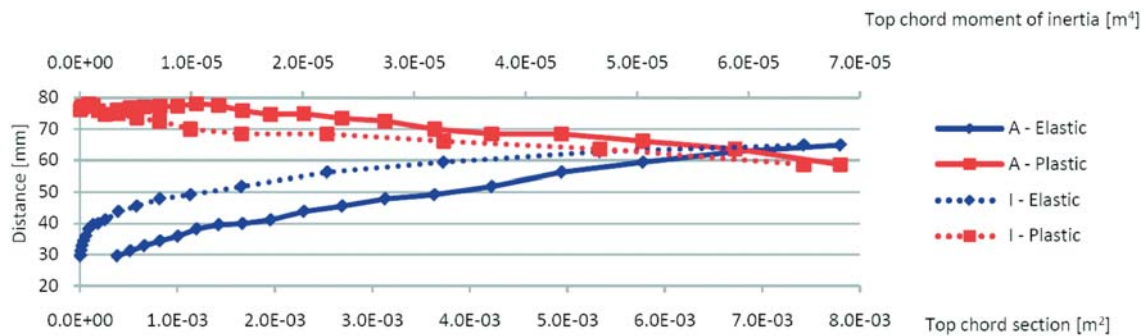

Fig. 4 Distance between the top chord and the composite truss centroids (ϕ 19 mm connectors)

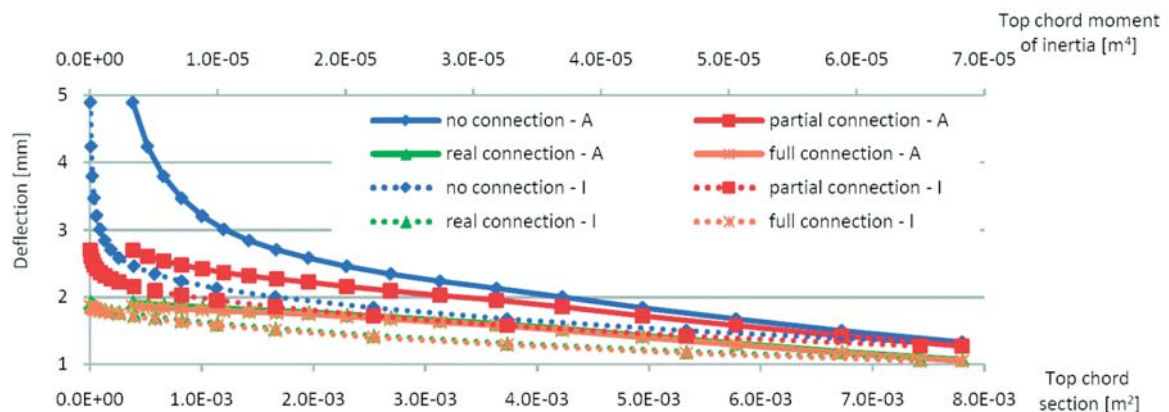

Fig. 5 Influence of the degree of connection on the stiffness of the truss

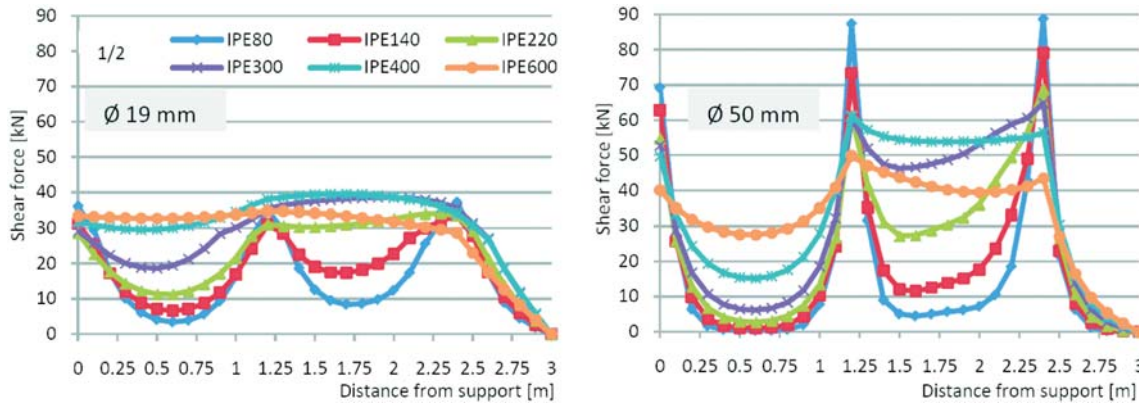

Fig. 6 Influence of the top chord section on the shear forces in the connectors (Ø 19 mm and 50 mm)

phenomenon is influenced by the ratio of geometry and resistance between the connector and the top chord section. Thus, it is necessary to optimize this ratio. Otherwise, the connectors in the panel area would transfer the predominant part of shear forces in comparison to the obvious zones on the chord between the nodes.

The influence of the material characteristics of concrete and structural steel on the distribution of shear forces in the connectors was analyzed in the additional parametrical study. The concrete strength is an input value in one of the formulae used to calculate the shear resistance of headed studs (1). Therefore, the greater value of concrete strength can provide a better shear force transfer in the connection. However the concrete strength does not affect significantly the shape of stress distribution by connectors (Fig. 7a). Impact of steel strength of truss material on the shear force distribution in the connectors (Fig. 7b) is small and can be neglected. However its influence on the resistance of the whole structure has to be considered.

4. Conclusion

The influence of different parameters of the steel-concrete composite truss on its behaviour was investigated by elastic and

plastic analysis. The parametric studies showed that the top chord sections have no significant effect on the flexural stiffness and load carrying capacity of the composite trusses, because they are usually located very near to the neutral axis of the composite member. However, the top chord section has an important influence on values of the shear forces in the connectors. In fact, the ratio between the characteristics of the shear connector and the top chord section governs the distribution of shear force along the beam. It is necessary to optimize this ratio and to develop the rules for predicting the distribution of shear forces in the connectors for various ratios of shear connectors and top chord sections. In this way more efficient use of the connectors can be achieved.

The influence of material characteristics of the structure components presented the next subject of our study. It was found that concrete strength affect the connector resistance, but has no significant effect on the redistribution of shear forces in the connectors. Similarly, the steel strength of the truss has little influence on the shear forces in connection.

The improvement of this promising model is in progress on the basis of 3D model using solid elements and local damage evolution of concrete. The aim is to take account of the local phenomena such as the plastic deformation between the connectors and

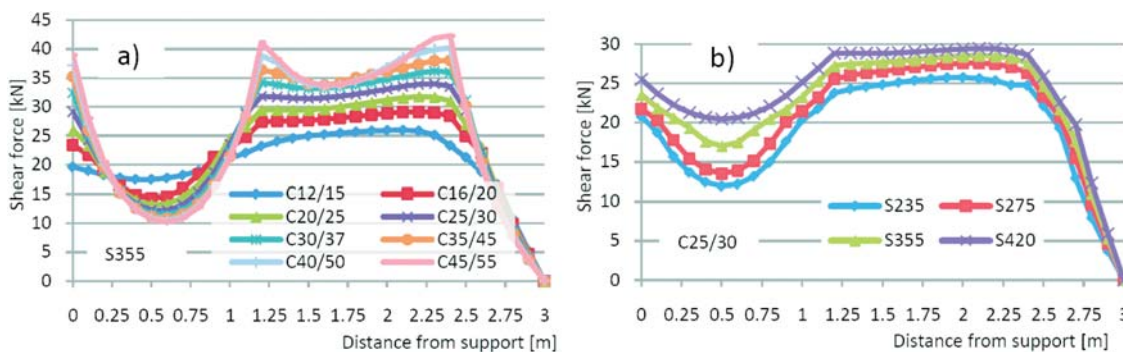

Fig. 7 Influence of material strength on the shear force distribution in the connectors: a) influence of the concrete strength of the slab, b) influence of the steel strength of the truss

the top chord on all the length of the chord including the panel points. The numerical model will be validated on the basis of experimental program including push-out tests and bending tests of composite trusses.

References

- [1] MACHACEK, J., CUDEJKO M.: *Shear Connection in Steel and Concrete Composite Trusses*, SDSS'Rio 2010 Stability and Ductility of Steel Structures, Rio de Janeiro, Brazil, 2010, p. 8.
- [2] MACHACEK, J., CUDEJKO M.: Longitudinal Shear in Composite Steel and Concrete Trusses, *Engineering Structures* 31, 2009, p. 1313-1320.
- [3] SCHAAP, B.: *Methods to Develop Composite Action in Non-Composite Bridge Floor Systems: Part I*, Master Thesis, University of Texas, Austin, 2004.
- [4] HUNGERFORD, B. E.: *Methods to Develop Composite Action in Non-Composite Bridge Floor Systems: Part II*, Master Thesis, University of Texas, Austin, 2004.
- [5] SAMUELSON, D.: Composite Steel Joist, *Engineering Journal*, 2002, p. 111-120.
- [6] ASCE Task Committee on Design Criteria for Composite Structures in Steel and Concrete (1996): Proposed Specification and Commentary for Composite Joists and Composite Trusses. ASCE Journal of Structural Engineering, Vol. 122, No. 4, April.
- [7] CEN. *Eurocode 4: Design of Composite Steel and Concrete Structures. Part 2: General rules and rules for bridges*. Brussels : CEN; 2005.
- [8] BUJNAK, J. *Global Analysis of Steel-concrete Composite Beams - Analytical Approach and Nonlinear Modelling (in French)*, PhD Thesis, Blaise Pascal University, Clermont-Ferrand II, France, 2007.
- [9] OLLGAARD, J.G., SLUTTER R.G., FISHER J.W. Shear Strength of Stud Connectors in Lightweight and Normal-density Concrete, *AISC Engineering Journal*, 1971, vol. 8, No. 2, p. 55-64.