

# COMMUNICATIONS

---

**3**

Tomas Skrucany - Stefania Semanova - Tomasz Figlus  
Branislav Sarkan - Jozef Gnap

**ENERGY INTENSITY AND GHG  
PRODUCTION OF CHOSEN PROPULSIONS  
USED IN ROAD TRANSPORT**

---

**10**

Jan Zamecnik - Juraj Jagelcak - Sven Sokjer-Peterssen  
Tomas Hvojník - Michal Lipka

**INFLUENCE OF A LASHING STRAP  
WINDING IN TENSIONING RATCHET  
ON THE RESULTS OF THE STRENGTH  
TESTS AND CYCLIC LOADING TESTS  
ACCORDING TO THE STANDARD  
EN 12 195-2**

---

**18**

Ondrej Stopka - Branislav Sarkan - Maria Chovancova  
Larisa M. Kapustina

**DETERMINATION OF THE APPROPRIATE  
VEHICLE OPERATING IN PARTICULAR  
URBAN TRAFFIC CONDITIONS**

---

**23**

Frantisek Brumercik - Michal Lukac  
Zbigniew Krzysiak - Leszek Krzywonos

**MODEL OF INTEGRATED  
TRANSPORTATION SYSTEM**

---

**27**

Michal Lukac - Frantisek Brumercik  
Leszek Krzywonos - Zbigniew Krzysiak

**TRANSMISSION SYSTEM POWER FLOW  
MODEL**

---

**32**

Eva Brumercikova - Bibiana Bukova - Pavol Kondek  
Pawel Drozdziel

**APPLICATION OF NFC TECHNOLOGY  
IN RAILWAY PASSENGER TRANSPORT  
BY INTRODUCING NEW PRODUCTS**

---

**36**

Anna Urbanek

**BIG DATA - A CHALLENGE FOR URBAN  
TRANSPORT MANAGERS**

---

**43**

Grzegorz Dydkowski - Anna Urbanek

**PRICES AS AN ELEMENT  
OF COMPARATIVE STUDIES ON PEOPLE'S  
TRAVELS IN CITIES**

---

**50**

Branislav Sarkan - Ondrej Stopka - Chenguang Li

**THE ISSUES OF MEASURING THE  
EXTERIOR AND INTERIOR NOISE  
OF ROAD VEHICLES**

---

**56**

Mariana Strenitzerova - Miriam Garbarova  
**IDENTIFICATION OF THE BARRIERS  
TO BUSINESS IN SLOVAKIA**

---

**61**

Jozef Gasparik - Vladimir Luptak - Petr V. Kurenkov  
Pavol Mesko

**METHODOLOGY FOR ASSESSING  
TRANSPORT CONNECTIONS ON THE  
INTEGRATED TRANSPORT NETWORK**

---

**68**

Carlos Lopez-Escolano - Angel Pueyo Campos  
Sergio Valdivielso Pardos - Eva Nedeliakova  
Vladimira Stefancova

**INCORPORATING BICYCLES INTO URBAN  
MOBILITY: AN OPPORTUNITY FOR  
SUSTAINABLE DEVELOPMENT**

---

**74**

Jiri Cejka - Mykola Guchenko

**OPTIMIZATION OF DISTRIBUTION  
ROUTES BY WAY OF THE MULTILEVEL  
APPROACH TO THE TRAVELING  
SALESMAN PROBLEM**

---

**80**

Andrea Galierikova - Jarmila Sosedova

**INTERMODAL TRANSPORTATION OF  
DANGEROUS GOODS**

---

**86**

Jan Lizbetin - Ladislav Bartuska  
Aleksandr Rakhmangulov

**COMPARATIVE ANALYSIS  
OF ALTERNATIVE FUELS USED IN ROAD  
TRANSPORT**

---

**90**

Lenka Cerna - Jozef Danis - Borna Abramovic  
**THE PROPOSAL OF A TARIFF TAKING  
INTO ACCOUNT THE RISK FROM  
UNOCCUPIED CAPACITY  
OF PASSENGER TRAINS**

---

**96**

Pawel Drozdziel - Kamil Wawer - Radovan Madlenak  
Murat Omarbekovich Mussabekov

**CONCEPTS OF LOAD HANDLING  
DEVICES, ADJUSTED TO LIGHT GOODS  
VEHICLES OF THE WEIGHT UP TO 3.5T**

---

**103**

Ladislav Bartuska - Karel Jerabek - Li Chenguang  
**DETERMINATION OF TRAFFIC PATTERNS  
ON URBAN ROADS**

---

**109**

Jaromir Siroky - Stephan Schroder - Jozef Gasparik  
**COMPARISON OF OPERATIONAL  
AND ECONOMIC ASPECTS OF DIRECT  
ROAD TRANSPORT AND CONTINENTAL  
COMBINED TRANSPORT**

---

**116**

Peter Piala - Andrea Galierikova - Andrej David  
**GLOBAL TRANSPORTATION  
OF FOODSTUFFS**

---

**120**

Milos Poliak - Lenka Komackova - Salvador Hernandez  
Marek Jaskiewicz - Gabriela Boldizsarova4

**SOURCES OF FINANCING PUBLIC  
PASSENGER TRANSPORT SERVICES**

---

**127**

Milos Poliak - Michaela Mrnikova - Marek Jaskiewicz  
Rafal Jurecki - Barbora Kaciakova

**PUBLIC TRANSPORT INTEGRATION**

---

**133**

Rudolf Kampf - Martina Hlatka - Gleb Savin  
**PROPOSAL FOR OPTIMIZING SPECIFIC  
DISTRIBUTION ROUTES BY MEANS  
OF THE SPECIFIC METHOD  
OF OPERATIONAL ANALYSIS**

---

**139**

Jana Stofkova - Katarina Gasova  
**FORMS OF CITIZENS' COMMUNICATION  
WITH THE PUBLIC ADMINISTRATION  
INSTITUTIONS**

---

**145**

Karel Havel - Vojtech Balint - Andrej Novak  
**A NUMBER OF CONFLICTS AT ROUTE  
INTERSECTIONS - RECTANGULAR  
MODEL**

---

**148**

Zuzana Juchova Juroskova - Boris Bucko  
**USER ORIENTED APPROACH  
IN INFORMATION COMMUNICATION  
TECHNOLOGY RESEARCH**

---

**153**

Katarina Zgutova - Miroslav Neslusan - Juraj Sramek  
Peter Danisovic - Jiri Capek  
**MONITORING OF SURFACE DAMAGE  
IN RAILS AFTER LONG TERM CYCLIC  
LOADING**

---

**159**

Lucie Sara Zavodna - Jan Zavodny Pospisil  
**YOUTUBE AS A NEW MEANS  
OF MARKETING COMMUNICATION**

---

**166**

Zoran Cekerevac - Zdenek Dvorak - Ludmila Prigoda  
Petar Cekerevac

**TECHNO-ECONOMIC ASPECT OF THE  
MAN-IN-THE-MIDDLE ATTACKS**

---

Tomas Skrucany - Stefania Semanova - Tomasz Figlus - Branislav Sarkan - Jozef Gnap\*

## ENERGY INTENSITY AND GHG PRODUCTION OF CHOSEN PROPULSIONS USED IN ROAD TRANSPORT

*Nowadays, there are more types of propulsions and fuels in road transport. This paper deals with the problem of their energy intensity and GHG emissions. The emissions can be classified as primary or secondary. The mixture of primary sources for the production of fuel or energy influence the final value of the ecological effectiveness of the propulsion. Methodology of the standard EN 16258:2012 was used for the estimation of this value.*

**Keywords:** Energy intensity, GHG production, fuels.

### 1. Introduction

Energy consumption and greenhouse gas (GHG) emissions are a still growing problem in today's society. Environmental impacts of transport are unfavourable and they often have unavoidable character. Therefore, the efficiency of transport in relation to energy consumption and GHG emissions is constantly monitored at present. Recently, demand for the vehicles using alternatives representing the not commonly used fuels is constantly increasing. Besides conventional fuels such as gasoline or diesel, we can also observe the increased use of fuels such as CNG, electricity or combination of fuels [1, 2 and 3].

### 2. Standard EN 16 258:2012

This European standard specifies a general methodology for calculation and declaration of energy consumption and GHG emissions in connection with any services (cargo, passengers or both). It specifies general principles, definitions, system boundaries, methods of calculation, allocation rules (allocation, assignment) and recommendations on information to support standardized, accurate, reliable and verifiable declarations regarding energy consumption and greenhouse gas emissions associated with any freight service. It also contains examples of the use of these principles.

The calculation for one given transport service must be performed using the following three main steps:

- Step 1: Identification of the various sections of the service
- Step 2: Calculation of energy consumption and greenhouse gas emissions for each section
- Step 3: Sum of the results for each section [4].

The standard does not consider only the secondary emissions produced and energy consumed during combustion of the fuel (energy conversion from fuel to mechanical energy), but also primary emissions incurred in the extraction, production and distribution:

- ew – well-to-wheels energy factor for the defined fuel,
- gw – well-to-wheels emission factor for the defined fuel,
- et – tank-to-wheels energy factor for the defined fuel,
- gt – tank-to-wheels emission factor for the defined fuel.

Well-to-wheels factor covers also primary and secondary emissions and consumption. Somewhere, this factor is also called life-cycle analysis/assessment (LCA). Tank-to-Wheels factor considers only secondary emissions and consumption.

This standard specifies a general methodology for calculation and the declared value for the energetic factor and factor in greenhouse gas emissions must be selected in accordance with Annex A [4].

Emission gases are composed of several individual components (gases). Each of them has different chemical and physical properties and thus participates in environmental degradation differently. In order to compare emissions from different activities, fuels, vehicles when emissions have different tracks, it is necessary to designate one representative unit usable for the comparison. This is the CO<sub>2</sub> equivalent, which is a measure of impact of

\* <sup>1</sup>Tomas Skrucany, <sup>1</sup>Stefania Semanova, <sup>2</sup>Tomasz Figlus, <sup>1</sup>Branislav Sarkan, <sup>1</sup>Jozef Gnap

<sup>1</sup>Department of Road and Urban Transport, Faculty of Operation and Economics of Transport and Communications, University of Zilina, Slovakia

<sup>2</sup>Department of Automotive Vehicle Construction, Faculty of Transport, Silesian University of Technology, Katowice, Poland

E-mail: tomas.skrucany@fpedas.uniza.sk

EN standard factors [authors based on EN 16 258:2012

Table 1

| Fuel                          | Energy factor                    |      |                                  |      | Emission factor                  |                        |                       |                                  |                        |                       |
|-------------------------------|----------------------------------|------|----------------------------------|------|----------------------------------|------------------------|-----------------------|----------------------------------|------------------------|-----------------------|
|                               | Tank-to-wheels (e <sub>t</sub> ) |      | Well-to-wheels (e <sub>w</sub> ) |      | Tank-to-wheels (g <sub>t</sub> ) |                        |                       | Well-to-wheels (g <sub>w</sub> ) |                        |                       |
|                               | MJ/kg                            | MJ/l | MJ/kg                            | MJ/l | gCO <sub>2</sub> e/MJ            | kgCO <sub>2</sub> e/kg | kgCO <sub>2</sub> e/l | gCO <sub>2</sub> e/MJ            | kgCO <sub>2</sub> e/kg | kgCO <sub>2</sub> e/l |
| Gasoline                      | 43.2                             | 32.2 | 50.5                             | 37.7 | 75.2                             | 3.25                   | 2.42                  | 89.4                             | 3.86                   | 2.88                  |
| Mixture Gasoline/Ethanol 95/5 | 42.4                             | 31.7 | 51.4                             | 38.4 | 72.6                             | 3.08                   | 2.30                  | 88.4                             | 3.74                   | 2.80                  |
| Diesel                        | 43.1                             | 35.9 | 51.3                             | 42.7 | 74.5                             | 3.21                   | 2.67                  | 90.4                             | 3.90                   | 3.24                  |
| Biodiesel                     | 36.8                             | 32.8 | 76.9                             | 68.5 | 0                                | 0                      | 0                     | 58.8                             | 2.16                   | 1.92                  |
| Liquid petroleum gas (LPG)    | 46.0                             | 25.3 | 51.5                             | 28.3 | 67.3                             | 3.10                   | 1,70                  | 75.3                             | 3.46                   | 1.90                  |
| Compressed natural gas (CNG)  | 45.1                             |      | 50.5                             |      | 59.4                             | 2.68                   |                       | 68.1                             | 3.07                   |                       |
| Marine diesel oil (MDO)       | 43.0                             | 38.7 | 51.2                             | 46.1 | 75.3                             | 3.24                   | 2.92                  | 91.2                             | 3.92                   | 3.53                  |

specific emissions and likens it to the impact of CO<sub>2</sub>. The label is CO<sub>2e</sub> (equivalent) [5, 6 and 7].

### 3. Equivalent CO<sub>2</sub>, CO<sub>2e</sub>

It is a universal measure of the amount of greenhouse gas (carbon dioxide, methane, nitrous oxide, etc.) which has the same effect on the climate system as carbon dioxide itself. It takes into account the exact degree of the impact of the greenhouse effect in the atmosphere generated by individual components of greenhouse gases. For example, one tonne of methane has 21 times greater degree of the greenhouse effect than one tonne of CO<sub>2</sub> and thus 1 tonne of methane represents the value of 21 t CO<sub>2e</sub>. This synthetic variable was created for the purpose of high explanatory power when comparing production of emissions from different industries, different sources and different fuels with varying composition [8, 9, 10 and 11].

Table 1 shows that not only the technical aspect of a vehicle and its efficiency to convert fuel energy to mechanical work but also the amount of energy spent on production, acquisition and distribution of fuel have an effect on the overall energy consumption. This represents a so-called LCA factor (a factor of a life cycle) which includes the well-to-wheels declaration method. The table also shows that when comparing direct energy consumption of a vehicle it is possible to achieve lower value of e<sub>t</sub> during combustion of biodiesel than during combustion of diesel. In the end, however, biodiesel is significantly worse when we compare the value of e<sub>w</sub>. Of course, it is also necessary to take into account the amount of fuel consumption during vehicle operation in that comparison. The consumption varies according to the

amount of energy contained in the fuel and efficiency of fuel combustion. Therefore, the extent of energy intensity of a certain vehicle may not be clear from the table. It is necessary to know the actual fuel consumption of the vehicle.

### 4. Electricity as the propulsion of road vehicles

Nowadays, the electric propulsion vehicles are increasingly penetrating the market. This propulsion is presented as clean and very acceptable for the environment because it produces no direct emissions. This fact predetermines these vehicles mainly for the use in urban areas and the surroundings in which emissions produced by road transport during combustion of fossil fuels are undesirable. However, to objectively compare different types of propulsion, secondary emissions should be also taken into account and thus the way of electricity production. Composition of the primary sources used for production of electricity and its conversion efficiency mainly influence the production of greenhouse gases. These two attributes are different in relation to regions of the production. If we consider regions as states, significant differences may be observed between individual countries.

Energy and emission factor (e<sub>w</sub>, g<sub>w</sub>) reflect a partial loss of production and distribution of power/energy in the chain:

1. energy mixture used in the manufacture of electric energy,
2. efficiency of power, various energy sources,
3. transfer efficiency (distribution) of electricity supply to the final consumer.

This fact implies that the effectiveness (efficiency) of electric energy is directly related to the power production technology,

the composition and proportions of individual resources and the effectiveness of its distribution.

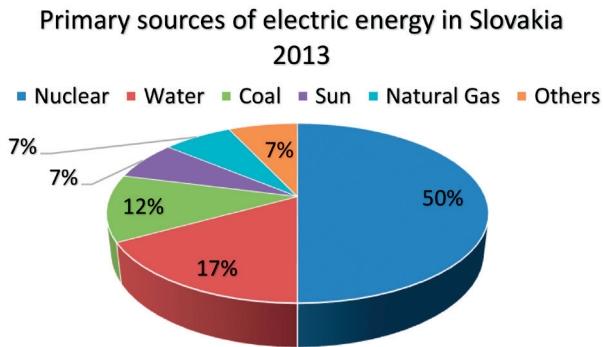

Fig. 1 Shares of the resources in the production of electricity [12 and 13]

Energy efficiency in electricity production can be calculated as a weighted arithmetic mean of primary resources and efficiency in power by various energy sources. Weight values represent the proportions of the various sources. Efficiency values were chosen on the basis of national regulation in Slovakia, which prescribes their height (Fig. 1).

Produced energy is delivered to consumers through the transmission system. This process took place without losses and efficiency of power transmission network in Slovakia was about 93 % last year [12 and 13].

The efficiency of vehicle system represent transmission losses from conduction through the whole vehicle traction system - losses from the vehicle energy source to the wheels. The efficiency of this process is approximately 90%. So, the overall energy efficiency of supplied power for rail transport in Slovakia is:

$$\eta_{CE} = \eta_V \cdot \eta_P \cdot \eta_{DP} = \left( \frac{\sum(\eta_{Zi} \cdot p_{Zi})}{p_Z} \right) \cdot \eta_P \cdot \eta_{DP} \quad (1)$$

- where:  $\eta_{CE}$  overall energy efficiency [-]
- $\eta_V$  efficiency of power energy [-]
- $\eta_P$  power transfer efficiency [-]
- $\eta_{DP}$  efficiency of vehicle system [-]
- $\eta_{Zi}$  effectiveness of a particular primary source [-]
- $p_{Zi}$  share of a given resource in the production of electric power [-]
- $p_Z$  sum of partial fractions of the individual sources [-]

The value of overall energy efficiency is 0.34. With regard to the value calculated on the basis of statistical data, but when compared, for example, with that in Germany, this value is the same.

### 5. Production of emissions and electric energy

The same procedure as for calculating the total energy efficiency can be used for the calculation of emission production. The procedure would be the same; it would be based on a share of individual sources and their emissions. We get the resulting value also by using the arithmetic mean. An easier way, however, is the use of so-called emission factor. This value is calculated for each country and includes the overall efficiency of electricity in a particular country, in addition to efficiency of the vehicle. Therefore, this emission factor should be used when comparing the country without a lengthy search for sub efficiency and emissions [14, 15 and 16].

LCA emission factors of EU-27 countries [17]

Table 2

| Country     | LCA emission factor (tCO <sub>2e</sub> /MWh) | Country        | LCA emission factor (tCO <sub>2e</sub> /MWh) |
|-------------|--|----------------|--|
| Austria     | 0.310  | Sweden         | 0.079  |
| Belgium     | 0.402  | Bulgaria       | 0.906  |
| Germany     | 0.706  | Cyprus         | 1.019  |
| Denmark     | 0.760  | Czech Republic | 0.802  |
| Spain       | 0.639  | Estonia        | 1.593  |
| Finland     | 0.418  | Hungary        | 0.678  |
| France      | 0.146  | Lithuania      | 0.174  |
| UK          | 0.658  | Latvia         | 0.563  |
| Greece      | 1.167  | Poland         | 1.185  |
| Ireland     | 0.870  | Romania        | 1.084  |
| Italy       | 0.708  | Slovenia       | 0.602  |
| Netherlands | 0.716  | Slovakia       | 0.353  |
| Portugal    | 0.750  | EU-27 average  | 0.578  |

For Slovakia, this value represents 0.353 tCO<sub>2e</sub>/MWh, what is 90.81 gCO<sub>2e</sub>/MJ.

### 5.1 Calculation and equations

To calculate the total energy consumption, the consumed amount of fuel should be multiplied by an emission factor for that fuel from Appendix A of the standard.

$$E_{CV} = S_{100km} \cdot \frac{1}{100} \cdot e_w \text{ [MJ]} \tag{2}$$

where:  $E_{CV}$  total energy consumption by a vehicle [MJ]  
 $S_{100km}$  vehicle fuel consumption per 100 km [l/100km]  
 $e_w$  energetic factor "wtw" for the defined fuel [MJ/l]

For GHG production the same procedure is applied as for the energy calculation, but the consumed amount of energy in fuel is multiplied by the emission factor from the EN standard.

$$G_{PV} = S_{100km} \cdot \frac{1}{100} \cdot g_w \text{ [gCO}_2\text{/km]} \tag{3}$$

where:

$G_{PV}$  amount of emissions produced by a vehicle [gCO<sub>2e</sub>/km]  
 $g_w$  emission factor for the defined fuel [kgCO<sub>2e</sub>/l or kg CO<sub>2e</sub>/kg]

Above written equations are valid for emission production of a vehicle driven by some type of fuel, but not for electrically powered vehicles. Next equations are used for them.

$$E_{CEV} = \left[ S_{100km} \cdot \frac{1}{100} \cdot 3.6 * \right] \cdot \eta_{CE} \text{ [MJ]} \tag{4}$$

where:

$E_{CEV}$  total energy consumption by an electric vehicle [MJ]  
 $S_{100km}$  vehicle primary energy consumption per 100 km [kWh/100km]  
 $e_w$  energy factor "wtw" for defined fuel [MJ/l]  
 $\eta_{CE}$  overall energy efficiency [-] (eq. 1)  
 \* for the fuel  $e_w$  factor is used, for electric traction in kWh 3.6 coefficient is used (energy unit conversion from kWh to MJ)

We used LCA emission factor to calculate the amount of emissions produced (Table 2). This factor already counts with efficiency of the electric power production, so the input for this equation is only primary energy consumption of the chosen vehicle. Also the conversion coefficient of electric units is not used, because this factor value is calculated for 1 kWh of consumed electricity.

$$G_{PEV} = \left[ S_{100km} \cdot \frac{1}{100} \right] \cdot g_{LCA} \text{ [gCO}_2\text{/km]} \tag{5}$$

where:

$G_{PEV}$  amount of emissions produced by an electric vehicle [gCO<sub>2e</sub>/km]  
 $g_{LCA}$  emission factor for electric power [kgCO<sub>2e</sub>/kWh] (Table 2).

### 6. Practical calculation

If we want to use a methodology for the calculation of energy intensity and GHG production in transport for passenger cars with different fuel types, it is suitable to use the following example.

Let us consider a vehicle frequently used in Slovakia and the Czech Republic which represents the middle class vehicle of an unnamed manufacturer who offers this type of vehicle with three types of propulsion - gasoline, gasoline/CNG and diesel with approximately the same engine power. Vehicle mark and model are not important in this case, but performance, weight parameters and fuel consumption of the vehicle are relevant. Curb weight of the vehicle is about 1 500kg and the vehicle engine power is about 80 kW. For this type of the vehicle, fuel consumption may range from 6 to 7 litres of gasoline per 100km; in the case of diesel engines it may be from 5 to 6 litres per 100 km and the vehicle consumption with CNG propulsion is about 5 kg/100km. Results of these calculations are in the table below (Table 3).

Fuel and energy consumptions stated by the manufacturer were used for the purposes of this calculation. The consumption

Calculation of energy consumption and GHG emissions [calculations according to 4 and 17]

Table 3

| Fuel         | Average fuel consumption<br>(l, kg, kWh/100km) | primary                       |                                       | primary + secondary           |                                       |
|--------------|--|-------------------------------|---------------------------------------|-------------------------------|---------------------------------------|
|              |  | Energy consumption<br>(MJ/km) | Production CO <sub>2e</sub><br>(g/km) | Energy consumption<br>(MJ/km) | Production CO <sub>2e</sub><br>(g/km) |
| Gasoline     | 5.6  | 1.80                          | 136                                   | 2.11                          | 161                                   |
| CNG          | 4.4  | 1.98                          | 118                                   | 2.20                          | 135                                   |
| Diesel       | 4.4  | 1.58                          | 117                                   | 1.88                          | 143                                   |
| electricity* | 20   | 0.72                          | 0                                     | 2.12                          | 65 / 149                              |
| hybrid**     | 4  | 1.29                          | 97                                    | 1.51                          | 115                                   |

\* this applies only for the consumed electric energy produced in the SR/CZ

\*\* variable value; it depends on regime of vehicle operation (city, highways); the used type of hybrid technology

was measured according to the standard. Consumption indicated by the manufacturer in the combined NEDC cycle is taken into account.

For comparison of other propulsion systems which are nowadays used in passenger cars, we chose the vehicles of the same category propelled by alternative technologies such as hybrid propulsion of gasoline/electric energy or fully electric cars.

The chart below (Fig. 2) shows the graphical results of the calculation of energy intensity and GHG emissions according to the methodology of the mentioned standard.

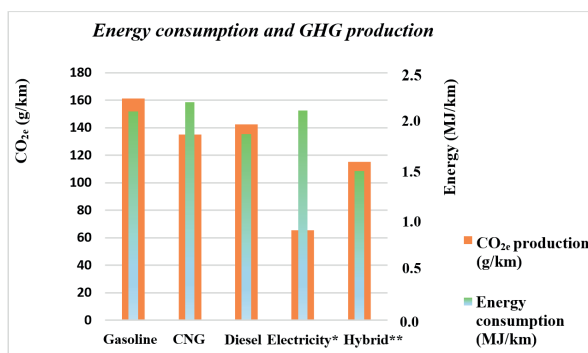

\* this applies only for the consumed electric energy produced in the SR/CZ

\*\* variable value; it depends on regime of vehicle operation (city, highways); the used type of hybrid technology

Fig. 2 Energy consumption and GHG production

The results in the chart (Fig. 2) represent energy consumption and GHG production from a global aspect, thus primary as well as secondary impacts are taken into account. CNG is the cleanest from hydrocarbon fuels in terms of GHG production. In terms of energy consumption, however, it represents the least efficient fuel despite the fact that its production/modification is not subject to such procedures as in the case of gasoline or diesel. This is caused by a large content of energy in 1 kg of CNG and thus engines combusting CNG achieve lower efficiency than the engines designed for gasoline or diesel.

When comparing the mentioned five vehicle propulsions, it also necessary to particularly look at electric vehicles and vehicles with hybrid technology of propulsion. The resulting energy consumption (primary as well as secondary) of electric vehicles greatly depends on the country in which those vehicles are driven or the country from which the electricity is used. In this regard, the way of electricity production is important, and thus the efficiency during its production and GHG emissions already in the process of its acquisition. This can be seen when comparing the results of the same electric vehicle operated in Slovakia or the Czech Republic. Therefore, the following part of the paper deals with this issue [10, 12 and 13] and the results are presented in the next Table 4.

In the case of hybrid vehicles, the resulting energy consumption may vary widely and thus also production of emissions, because this type of propulsion reaches greater differences in terms of the regime of vehicle operation. Vehicle consumption within urban areas may represent a very small amount. But, the use of hybrid vehicles on highways may result in equal or even higher vehicle consumption compared to comparable vehicles with conventional propulsion for combusting hydrocarbon fuels [18, 19 and 20].

Comparison of CO<sub>2e</sub> in the selected EU countries

[calculations according to 4 and 17]

Table 4

| Country  | Vehicle energy consumption (kWh/100km) | Tank-to-wheels Production CO <sub>2e</sub> (g/km) | Well-to-wheels Production CO <sub>2e</sub> (g/km) |
|----------|--|---|---|
| Estonia  |  |   | 318.6   |
| Slovakia |  |   | 70.6  |
| Germany  | 20                                     | 0   | 141.2   |
| EU - 27  |  |   | 115.6   |
| Sweden   |  |   | 15.8  |

Figure 3 graphically shows the results of the calculation of GHG production of different propulsions. The left side of the chart contains data on the fuels which are combusted in combustion engines and hybrid technology. The results of these fuels are relatively similar. There are only minor differences. The values are in the range about 115 - 160 gCO<sub>2e</sub>/km and the average value is 138 gCO<sub>2e</sub>/km (the left orange bar in the chart).

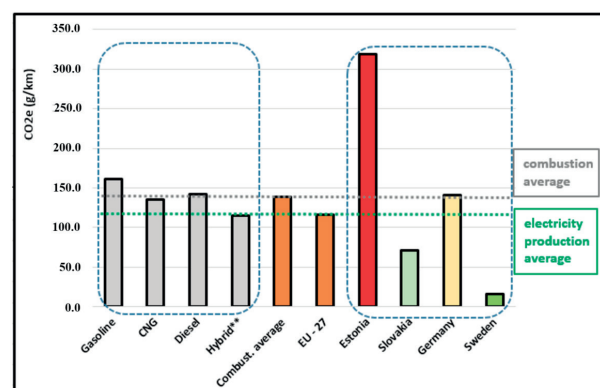

Fig. 3 Comparison of GHG production for different types of propulsion of road vehicles

On the right side of the chart (Fig. 3), there are results of the vehicles propelled by electric energy produced in different EU states. These results are greatly different. In Estonia, GHG emissions during electricity production represent the highest value from EU states. Compared to Sweden, the GHG production is approximately 20 times lower. This is caused by the fact that

both states use different sources. If fossil fuels are mainly used in electricity production (e.g. Estonia, Poland, Greece), electric energy will never be “green” and it will reach higher values of GHG production than conventional fuels for combustion engines. In countries such as Sweden and Austria, hydroelectric and nuclear power plants and renewable resources are mainly used and thus this way of electricity production is indeed environmentally acceptable.

## 7. Conclusion

The results presented in this paper show the difficulty in comparing energy consumption and GHG production in transport when using different fuels. This is caused by chemical

composition of the fuel, the form of energy contained in it, its production, distribution and storage. Thus not only the fuel itself and efficiency of its energy conversion in a vehicle (fuel consumption of a vehicle) have impacts on the environment, but also all procedures used for acquisition and processing of the fuel and its environmental friendliness must be considered. Another very important factor in the assessment of the effects of selected vehicle propulsions on the environment is the place of production, especially in the case of electric energy. Large differences in primary sources and efficiency of different technologies used in electricity production cause significant differences in energy efficiency and GHG production. These differences may be observed in different countries and even regions.

## References

- [1] KALINA, T., JURKOVIC, M., GROBARCIKOVA, A.: *LNG - Great Opportunity for the Inland Water Transport*. Proc. of the 19<sup>th</sup> intern. Scientific conference Transport Means 2015, October 22-23, 2015, 489-492, Kaunas University of Technology.
- [2] RIEVAJ, V., MOKRICKOVA, L., RIEVAJ, J.: Impact of Driving Techniques on Fuel Consumption. *Communications - Scientific Letters of University of Zilina*, vol. 18, No. 2, 2016, 72-75.
- [3] RIEVAJ, V. et al: The Impact of Air Resistance on the Fuel Consumption in Real Conditions within the Transport Operation. *Communications - Scientific Letters of the University of Zilina*, vol. 18, No. 2, 2016, 57-61.
- [4] European standard EN 16 258:2012. Methodology for Calculation and Declaration of Energy Consumption and GHG Emissions of Transport Services (freight and passengers).
- [5] KUCERA, L., GAJDAC, I., MRUZEK, M.: Simulation of Parameters Influencing the Electric Vehicle Range. *Communications - Scientific Letters of the University of Zilina*, vol. 18, No. 1A, 2016, 59-63.
- [6] KNEZ, M., MUNEER, T., JEREB, B., CULLINANE, K.: The Estimation of a Driving Cycle for Celje and a Comparison to other European Cities. *Sustainable Cities and Society*, vol. 11, 2014, 56-60.
- [7] KNEZ, M., JEREB, B., OBRECHT, M.: Factors Influencing the Purchasing Decisions of Low Emission Cars: A Study of Slovenia. *Transportation Research, Part D, Transport and Environment*, vol. 30, 2014, 53-61.
- [8] ISO 14064:2006. International standard for GHG Emissions Inventories and Verification. Part 1: Specification with guidance at the organization level for quantification and reporting of GHG emissions and removals.
- [9] LISCAK, S., RIEVAJ, V., SULGAN, M.: Vehicle's Technical Condition and Emission. *Eksplatacja i Niezawodnosć - Maintenance and Reliability*, 37(1), 2008, 61-63.
- [10] KALINA, T., JURKOVIC, M., BINOVA, H., GARDLO, B.: Water Transport - The Challenge for the Automotive Industry in Slovakia. *Communications - Scientific Letters of the University of Zilina*, vol. 18, No. 2, 2016, 26-29.
- [11] BARTH, M., BORIBOONSOMSIN, K.: Energy and Emissions Impacts of a Freeway-Based Dynamic Eco-Driving System. *Transportation Research, Part D: Transport and Environment*, vol. 14, No. 6, 400-410.
- [12] SKRUCANY, T. et al.: Software Simulation of an Energy Consumption and GHG Production in Transport. *Communications in Computer and Information Science*, vol. 531, 2015, 151-160.
- [13] SKRUCANY, T., GNAP, J.: *Energy Intensity and Greenhouse Gases Production of the Road and Rail Cargo Transport using a Software in Simulate the Energy Consumption of a Train*. Proc. of 14<sup>th</sup> intern. Conference on Transport Systems Telematics: Telematics - Support of Transport, TST 2014, Berlin: SPRINGER-VERLAG, 2014, 263-272.
- [14] HRMADKO, J., MILLER, P., HONIG, V.: Use of the Vehicle Movement Model to Determine Economic and Environmental Impact Caused by Separate Vehicles. *Eksplatacja i Niezawodnosć - Maintenance and Reliability*, 1: 70-73, 2009.
- [15] VAISHNAV, P.: Greenhouse Gas Emissions from International Transport. *Issues in Science and Technology*, vol. 30, No. 2, 2014, 25-28.

- [16] GARCIA-ALVAREZ, A., PEREZ-MARTINEZ, P. J., GONZALEZ-FRANCO, I.: Energy Consumption and Carbon Dioxide Emissions in Rail and Road Freight Transport in Spain: A Case Study of Car Carriers and Bulk Petrochemicals. *J. of Intelligent Transportation Systems*, Philadelphia, 2013, ISSN 1547-2450.
- [17] Technical annex to the SEAP template instructions document: The emission factors. Document of the European Commission.
- [18] DAVILA, A.: Report on Fuel Consumption. Project 233683 SARTRE, ECE, 2013.
- [19] KALINA, T., GROBARCIKOVA, A.: LNG as Alternative Fuel for European Transport System. *Communications - Scientific Letters of the University of Zilina*, vol. 16, No. 2, 2014, 70-76.
- [20] CABAN, J., DROZDZIEL, P., BARTA, D., LISCAK, S.: Vehicle Tire Pressure Monitoring Systems, *Diagnostyka - Diagnostics*, vol. 15, No. 3, 2014, 11-14.

Jan Zamecnik - Juraj Jagelcak - Sven Sokjer-Peterssen - Tomas Hvojnik - Michal Lipka\*

## INFLUENCE OF A LASHING STRAP WINDING IN TENSIONING RATCHET ON THE RESULTS OF THE STRENGTH TESTS AND CYCLIC LOADING TESTS ACCORDING TO THE STANDARD EN 12 195-2

*This article is focused on the results of the testing of the complete web lashing and the cyclic loading tests of selected lashing straps of three various producers according to the standard EN 12 195-2. It analyses how the quantity of winding in tensioning ratchet affects the results of these tests, whereas it compares the results of the straps wound 2¼ times around the rotating axis (as is correct according to the standard) and those wound 1¼ times around the rotating axis (as is not enough quantity of a winding). The article concludes that the influence of the winding on elongation of straps as well as on operating life of the straps is strong. Damages on particular parts of complete lashing straps, which were found out within these tests, are also presented in the article.*

**Keywords:** Lashing straps, cyclic loading tests, tests of the complete web lashing, elongation, force at break.

### 1. Introduction

Lashing straps made of synthetic fibres are very often used for cargo securing in road transport because of their advantages, such as low weight, sufficient length, simple and fast handling and relatively low price of standard types. Among them, the 50mm wide polyester lashing straps with 2 500 daN lashing capacity are the most often used to secure heavier cargo, e. g. palletized cargo [1]. Requirements for performance and testing of textile lashing straps and tensioning devices are defined in the standard EN 12 195-2. It prescribes type tests for new types of straps as well as production tests which have to be carried out continuously during the production. It prescribes the following type tests to be performed on standard combination of lashing straps with the ratchet:

- tensile test of textile webbings (without tensioning device and end fittings),
- testing of the complete web lashing,
- test of pre-tension ability of tensioning device (ratchet),
- test of the ability to release under tension,
- cyclic loading test of tensioning device,

- strength test of the ratchet handle,
- test of recoil.

The first two tests listed above have to be performed also continuously during production of lashing straps as so called production tests. The standard EN 12 195-2 prescribes a way of sampling and a sampling rate for the production tests.

In practice, inferior lashing straps and their tensioning devices (ratchets) are also sold on the market, whereas it is not possible to recognize their low quality visually without professional testing. But high forces can act on the straps in practice, mainly for short-term during emergency braking or evasive manouvering [2 and 3]. This may cause a break or loosening of such inferior (or damaged) lashing straps and inertial forces may cause a movement of loose cargo. As a consequence, it means not only material damages and losses, but also a threat for a driver, other road traffic users and nearby persons. The driver can not avoid emergency braking or manouvering in most cases, because this need is often caused by other road traffic users. Moreover, traffic accidents of heavy vehicles affect and endanger other road traffic users severely [4]. Results of the tests performed by the University of Zilina point at the fact that not all lashing straps available

\* <sup>1</sup>Jan Zamecnik, <sup>1</sup>Juraj Jagelcak, <sup>2</sup>Sven Sokjer-Peterssen, <sup>3</sup>Tomas Hvojnik, <sup>3</sup>Michal Lipka

<sup>1</sup>Department of Road and Urban Transport, Faculty of Operation and Economics of Transport and Communications, University of Zilina, Slovakia,

<sup>2</sup>MariTerm AB, CEO, Hoganas, Sweden

<sup>3</sup>Forwarding and Logistics at the Department of Road and Urban Transport, Faculty of Operation and Economics of Transport and Communications, University of Zilina, Slovakia

E-mail: jan.zamecnik@fpedas.uniza.sk

on market comply with the quality and safety requirements [5]. Tests described in this article consist of the tests of the complete web lashing according to 6.4. of the standard EN 12 195-2 and the cyclic loading tests according to 6.5.3. of the standard. These tests were performed on samples of straps made by three various producers. The influence of the quantity of winding in tensioning ratchets on test results was studied. The tests confirmed strong influence of the quantity of winding of webbing in ratchets on the tests results.

## 2. Test of the complete web lashing

The lashing capacity (LC) stated on lashing strap labels means the maximum force for use in straight pull that a web lashing is designed to sustain in use [6]. The standard EN 12 195-2 prescribes that a new complete lashing strap consisting of a textile webbing, tensioning ratchet and end fittings has to withstand a load equivalent to 1.25 LC acting during one minute without any permanent deformation or any other defect which affects its function. Subsequently, the strap should be inspected. No deformations on any of its parts, seam failure or slippage of the textile webbing through the tensioning device should occur. Tensioning devices or components with moving parts should fully retain their function and a space between a strap and a webbing slot of tensioning device should not be less than 2 percent of width of the strap. When the complete web lashing complied with this part of the test, it has subsequently to withstand a load equivalent to at least 2 LC without failure (safety factor 2). Testing of the complete web lashing **should be performed with 2 ¼ turns** of web lashing around the rotating axis of the ratchet. As a part of this test it has to be checked, whether no sharp edges are in contact with the webbings or with the operator's hands, because it would reduce the lashing capacity of the strap or injure the operator respectively [6].

## 3. Cyclic loading test of tensioning device

Cyclic loading test of tensioning device is an important test, because it shows whether the strap exposed to cyclic, alternating load does not elongate excessively or release in a winding around the rotating axis. A complete lashing strap is exposed to 100 cycles between 0.2 LC and 1 LC where each cycle should last at least 2.5 seconds<sup>1</sup>. The standard EN 12 195-2 prescribes maximum allowed elongation within 100 cycles for lashing straps with particular lashing capacities. The straps with LC = 2 500 daN must not elongate more than 20 mm. The test has to be carried out with 2 ¼ turns of web

<sup>1</sup> Before that, it is loaded in straight pull by a force equivalent to LC and then the load is reduced to 0.2 LC

lashing around the rotating axis of a ratchet. The sample used for the cyclic loading test may be used for the determination of the breaking force [6].

Repetitive cyclic load of the straps used for cargo securing in containers on vessels or in semi-trailers transported on ferries may occur e.g. in sea transport due to waves. The most critical is the sea area C and transverse direction where we have to consider inertial forces up to 0.8 G. In longitudinal direction (forwards and backwards) the securing effect of friction is significantly lowered. Bigger waves cause bigger inclinations of vessels and higher forces in lashing straps, and this effect repeats again and again [7 and 8].

## 4. Straps used for the tests

We used tensioning devices made by two different producers and loose ends by three producers of webbing loose ends to carry out the tests. Although the standard EN 12 195-2 requires these tests to be performed with 2 ¼ turns of web lashing around the rotating axis of ratchet, we also compared results of the tests performed correctly according to the standard with 2 ¼ turns of winding in a ratchet with those performed with similar straps with insufficient 1 ¼ turns of winding in a ratchet.<sup>2</sup> Our tests were performed on testing machine Testometric M500-100CT in the laboratory of the Department of road and urban transport of the University of Zilina. The tests were carried out with 1 m long samples (only the sample of old, worn strap OFS1/OL1 was lengthened to 2 m to examine, on which of the worn and damaged places the strap breaks).

We marked the tensioning devices used for the tests with a marking consisting of three letters and one digit. The first letter means a marking of producer (letters "A" or "B"), the second one is the letter "F" meaning that the sample is a fixed end containing tensioning device, the third letter distinguished the tensioning devices with short ratchets (letter "S") and those with long ratchets (letter "L"). A digit at the end was a serial number of the same sample type. Loose ends without tensioning devices were marked similarly with a difference that the marking consisted only of two letters (the first letter "A", "B" or "C" meaning different producers and the second letter "L" meaning that the sample is a loose end) and a serial number. For example, marking AFS1 means the first sample of a fixed end with short ratchet made by producer A. For comparison, a strength test of an old and worn strap was also carried out. All the straps used for the testing had a lashing capacity of 2 500 daN and producer's declared elongation up to 7% in a force equivalent to LC.

<sup>2</sup> However, 1 ¼ turn is required for the measurement of Standard tension force according to 6.5.1 of EN 12195-2.

**5. Comparison of the results of the testing of the complete web lashing and cyclic loading tests of lashing straps carried out with 1 ¼ and 2 ¼ turns of winding in a ratchet**

Results of the tests of lashing straps confirmed that a quantity of winding in ratchet strongly affects strength, elongation and damages of the straps during such tests. Our tests were carried out with the same samples firstly tested by the cyclic loading tests and subsequently by the tests of the complete web lashing. Results of these tests are given in Table 1 in absolute values (values in millimeters rounded off to one decimal) and in Table 2 in percents of required values. Particular colours used in the tables mark comparable samples.

The results given above in Tables 1 and 2 clearly show that the quantity of a winding in a ratchet affects strongly an elongation of the straps after cyclic loading tests. All samples tested with 1 ¼ turns of winding reached significantly higher elongation after 100 cycles than that is a maximum allowed value. In some cases, this elongation exceeded the allowed value several times. The worst result was measured on the

sample AFS2/AL2, which exceeded it 7.6 times. On the other hand, both samples of the same type tested with 2 ¼ turns of winding in a ratchet met the prescribed requirements, because their elongation reached 63.44 and 68.29% of maximum allowed elongation of 20 mm. All the samples (same or comparable to those tested with 1 ¼ turns of winding) tested with 2 ¼ turns of winding met the requirements of the standard for cyclic loading tests except of the sample AFL3/AL6, where a severe qualitative fault occurred, because a break of the ratchet split pin occurred just in the first cycle of cyclic loading tests at force 1 473 daN. It affected the final result of the cyclic loading test, because this damage caused a decrease of force and the strap was released by 10mm immediately (Fig. 1).

If good-quality ratchets with correct quantity of winding are used, run of elongation within particular cycles of the cyclic loading tests has a logarithmic character where after higher elongation between several first cycles, further elongation in next cycles is relatively stable and low. But if insufficient, poor-quality ratchets or ratchets with a low quantity of winding (as in our tests with 1 ¼ turns of winding in ratchets) are used, the elongation between each cycle is

Results of the cyclic loading tests (elongation) and the tests of complete web lashing (elongation at force equivalent to LC and force at break)

Table 1

| Combination of samples  | Elongation after cyclic loading tests [mm] |                      | Elongation at force equivalent to LC [mm] |                      | Force at break [daN] |                      |
|-------------------------|--|----------------------|---|----------------------|----------------------|----------------------|
|                         | 1 ¼ turns of winding                       | 2 ¼ turns of winding | 1 ¼ turns of winding                      | 2 ¼ turns of winding | 1 ¼ turns of winding | 2 ¼ turns of winding |
| AFS1/AL1                | 94.1                                       | 12.7                 | 5.5                                       | -                    | 3 549                | -                    |
| AFS2/AL2                | 152.5                                      | -                    | 4.8                                       | -                    | 5 108                | -                    |
| AFS3/AL5                | -  | 13.7                 | -   | 6.1                  | -                    | 5 163                |
| AFS1/CL1                | 66.7                                       | -                    | -   | 4.9                  | -                    | 5 540                |
| AFL1/AL3                | 70.7                                       | -                    | 3.9                                       | -                    | 3 813                | -                    |
| AFL1/AL6                | -  | 7.9                  | -   | 6.4                  | -                    | 5 352                |
| AFL2/AL4                | 57.1                                       | -                    | 3.6                                       | -                    | 4 228                | -                    |
| AFL3/AL6                | -  | 21.6 <sup>3</sup>    | -   | -                    | -                    | -                    |
| AFL1/CL2                | 33.6                                       | 11.0                 | -   | 5.1                  | -                    | 5 532                |
| BFL2/AL3                | 103.1                                      | -                    | -   | -                    | -                    | -                    |
| BFL1/BL1                | 62.1                                       | 14.4                 | -   | 7.1                  | -                    | 4 793                |
| BFL2/BL2                | 45.1                                       | 8.9                  | -   | -                    | -                    | -                    |
| BFL1/CL3                | 31.7                                       | 10.9                 | -   | 4.6                  | -                    | 4 724                |
| BFL2/CL4                | 34.6                                       | 10.6                 | -   | 4.7                  | -                    | 5 680                |
| OFS1/OL1                | -  | -                    | -   | 5.7                  | -                    | 3 302                |
| Mean value <sup>4</sup> | 68.3                                       | 11.3                 | 4.5                                       | 5.6                  | 4 175                | 5 255                |

Source: Authors

<sup>3</sup>In this case, a break of the ratchet split pin occurred just in the first cycle of the cyclic loading tests. This caused that the sample was elongated by 10 mm immediately. If this damage did not occur, the requirement of 20 mm elongation as a maximum would be probably met, but occurrence of such a damage is a severe qualitative fault of the ratchet.

<sup>4</sup> Except of the sample OFS1/OL1

Results of the cyclic loading tests (elongation) and the tests of complete web lashing (elongation at force equivalent to LC and force at break) in relative expression (results which do not meet requirements of the standard EN 12 195-2 are red coloured) Table 2

| Combination of samples  | Elongation after cyclic loading tests [% of maximum allowed value] |                      | Elongation at force equivalent to LC [% of maximum allowed value] |                      | Safety coefficient - ratio of real force at break and lashing capacity of a strap <sup>5</sup> |                      |
|-------------------------|--|----------------------|---|----------------------|--|----------------------|
|                         | 1 ¼ turns of winding   | 2 ¼ turns of winding | 1 ¼ turns of winding  | 2 ¼ turns of winding | 1 ¼ turns of winding   | 2 ¼ turns of winding |
| AFS1/AL1                | 470.4  | 63.4                 | 78.7  | -                    | 1.42   | -                    |
| AFS2/AL2                | 762.6  | -                    | 68.1  | -                    | 2.04   | -                    |
| AFS3/AL5                | -  | 68.3                 | -   | 87.8                 | -  | 2.07                 |
| AFS1/CL1                | 333.3  | -                    | -   | 69.7                 | -  | 2.22                 |
| AFL1/AL3                | 353.6  | -                    | 56.2  | -                    | 1.52   | -                    |
| AFL1/AL6                | -  | 39.7                 | -   | 91.1                 | -  | 2.14                 |
| AFL2/AL4                | 285.7  | -                    | 52.0  | -                    | 1.69   | -                    |
| AFL3/AL6                | -  | 108.2 <sup>3</sup>   | -   | -                    | -  | -                    |
| AFL1/CL2                | 167.8  | 54.9                 | -   | 72.9                 | -  | 2.21                 |
| BFL2/AL3                | 515.7  | -                    | -   | -                    | -  | -                    |
| BFL1/BL1                | 310.7  | 72.0                 | -   | 101.7                | -  | 1.92                 |
| BFL2/BL2                | 225.3  | 44.5                 | -   | -                    | -  | -                    |
| BFL1/CL3                | 158.6  | 54.5                 | -   | 65.3                 | -  | 1.89                 |
| BFL2/CL4                | 173.0  | 52.8                 | -   | 67.2                 | -  | 2.27                 |
| OFS1/OL1                | -  | -                    | -   | 82.1                 | -  | 1.32                 |
| Mean value <sup>4</sup> | 341.5  | 62.0                 | 63.8  | 79.4                 | 1.67   | 2.10                 |

Source: Authors

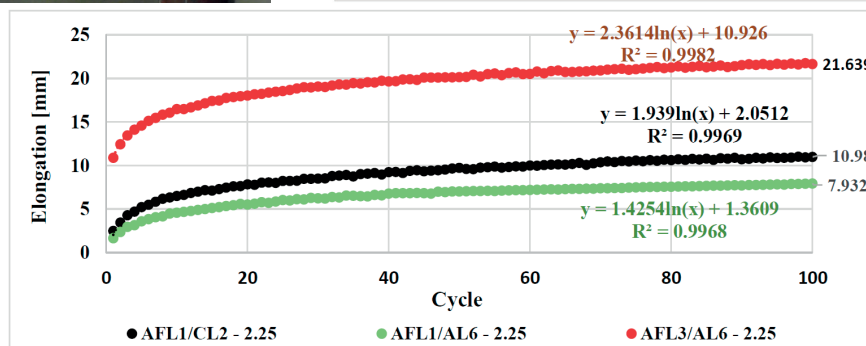
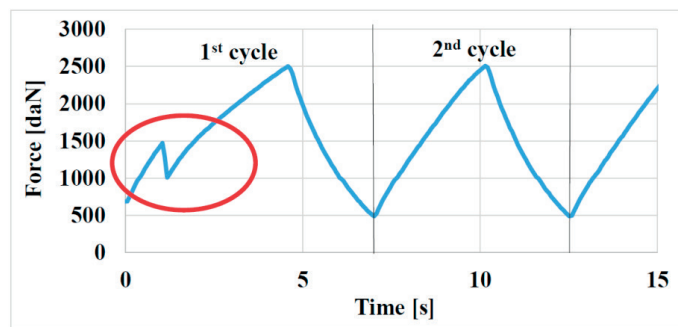
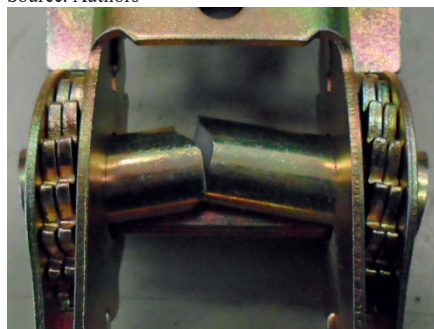

Source: Authors

Fig. 1 The split pin of the ratchet AFL3 which broke just after the first cycle of cyclic loading tests (up on the left), influence of this damage on the run of force during the cyclic test (up on the right) and run of elongation within particular cycles of the cyclic loading test in comparison with the second sample of the same type complete lashing strap without this damage AFL1/AL6 and with another sample with the same type ratchet and other type strap AFL1/CL2 (down)

<sup>5</sup> The standard prescribes a minimum safety coefficient 2 for new straps, because this coefficient is considered to cover worsening of their characteristics due to use and standard wear.

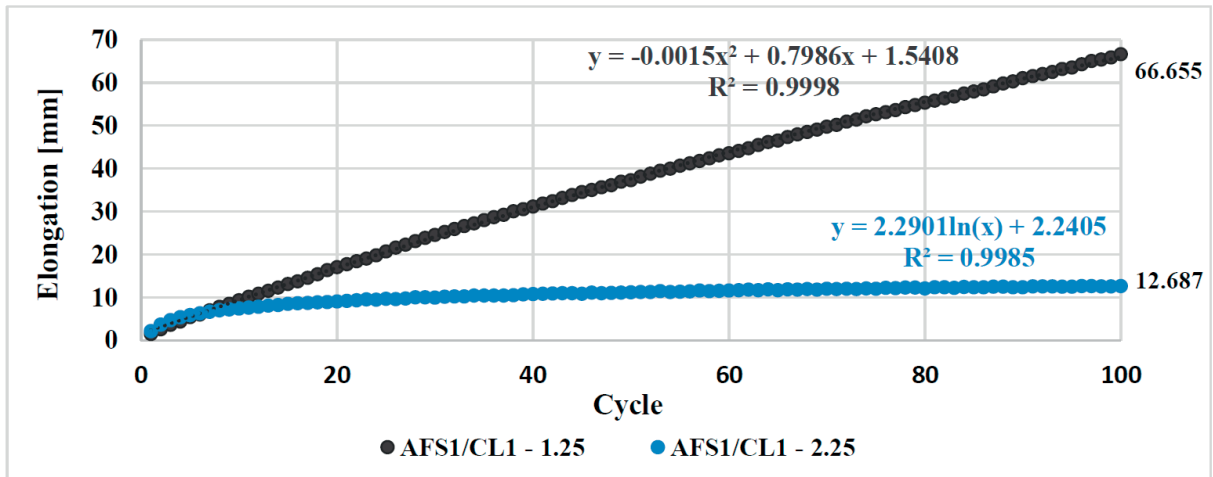

Source: Authors

Fig. 2 Run of elongation of the same type of lashing strap and ratchet sample AFS1/CL1 tested with 1¼ and with 2¼ turns of winding in the ratchet - logarithmic run for 2¼ turns of winding in the ratchet, linear run for 1¼ turns of winding in the ratchet

almost linear throughout the test and the strap loose evenly during whole test performance. Figure 2 compares elongation of two samples of the same type of lashing strap with 1¼ and 2¼ turns of winding in a ratchet. If 1¼ turns of winding in a ratchet is used, a strap is sequentially pulled out from the ratchet winch in each cycle, which causes high final elongation. It means that such straps are not capable to hold lashing forces and the webbing is subsequently released from the ratchet in the case of repeatedly occurring load caused by dynamical strain during transport. This may cause movement of cargo, danger and in the worst cases also a traffic accident due to loss of cargo securing (mainly in the case of transport of heavy pieces of cargo). In extreme cases, a lashing strap may be completely pulled out from a ratchet before the cyclic

loading tests are finished. Other research showed that some types of poor-quality ratchets, which are frequently sold on the market and used in practice, reach with 2¼ turns of winding in the ratchet the similar results of elongation and pulling out from the ratchets as our straps tested with 1¼ turns of winding [9].

When the cyclic loading tests with 1¼ turns of winding in a ratchet were performed and the lashing straps were pulled out from the ratchets, edges of the straps were damaged due to contact of textile web lashing with sharp edge of the tensioning ratchet (Fig. 3), which came to be placed slightly askew due to releasing of the web lashing strap. In some cases (with straps made by producer A) the edges of the straps were severely damaged and these damages affected results of the

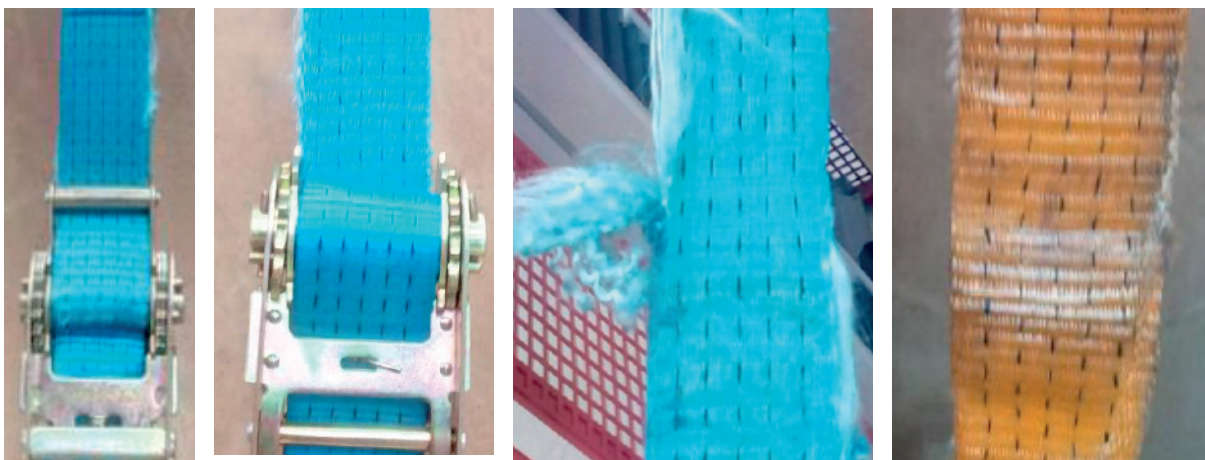

Source: [10]

Fig. 3 Tested lashing straps after cyclic loading tests performed with 1¼ turns of winding in a ratchet. From the left are samples: BFL2/AL3, AFS2/AL2 (this sample met the requirements of strength test reaching force at break 5 108 daN), AFS1/AL1 (this sample did not meet the requirements of strength test reaching force at break 3 549 daN) and AFS1/CL1

strength tests performed subsequently after the cyclic loading tests. Such damaged lashing straps did not withstand a force equivalent to double lashing capacity as is required by the standard EN 12195-2 (see results of the samples AFS1/AL1, AFL1/AL3 and AFL2/AL4, where the strength tests were carried out after cyclic loading tests). When the cyclic loading tests were carried out with  $2\frac{1}{4}$  turns of winding in ratchet, no such damages occurred.

Also the straps made by producer B tested with  $1\frac{1}{4}$  turns of winding in ratchet reached excessive elongation, but damaging of their edges was smaller than on the straps of producer A. In the tests of the complete web lashing the following parameters were observed: elongation at force equivalent to LC and 1.25 LC, deformations and movement of the parts of the complete lashing strap after the load equivalent to 1.25 LC acting during one minute as well as force at break, which should reach at least double LC. No movement of the textile webbing in ratchet or permanent deformations of any parts of the complete web lashing which may negatively affect its function may occur after a load equivalent to 1.25 LC acting during one minute. No deformations on any of tested long ratchets were observed, but some small deformations (dishing) of split pins on the short ratchets AFS1 - AFS3 were observed (Fig. 4). Damages on the edges of webbing, which had occurred during cyclic loading tests on some samples, became yet worsened, but no sample broke during this part of the testing. Elongation during one minute of holding the force at 3 125 daN (1.25 LC)<sup>6</sup> reached 0.2 - 0.4% in most of the cases (regardless of the quantity of winding) and 0.5 - 0.6% on the samples AFL1/AL6, AFS3/AL5 and on the sample of old and worn strap OFS1/OL1 (each of them with  $2\frac{1}{4}$  turns of winding in ratchet). These three samples also reached the worst results of elongation at the tests of the complete web lashing at all.

Tested short ratchets reached worse results of elongation at 1.25 LC (elongation 6.204% - 7.34% at the beginning of acting such force and 6.42% - 7.91% at the end) than tested new long ratchets (elongation 4.07% - 5.92% at the beginning of acting the force and 4.31 - 6.43% at the end). The highest elongation at this test was measured on the old and worn strap, where the results were 7.79% at the beginning and 8.30% at the end of holding the force equivalent to 1.25 LC.

Results of the tests in Tables 1 and 2 show that higher elongation (at the force equivalent to LC) was observed in the case when  $2\frac{1}{4}$  turns of winding in ratchet were used in comparison with tests when  $1\frac{1}{4}$  turns of winding were used. It was caused by compressing of bigger quantity of webbing wound around the rotating axis of a ratchet.

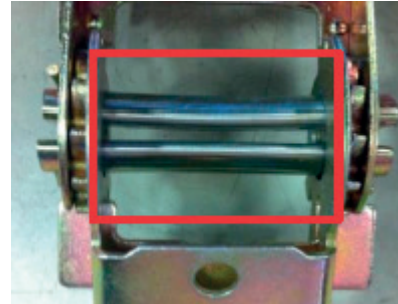

Source: [11]

Fig. 4 Slightly deformed (dished) split pin of short ratchet IFS1 after the test with force 1.25 LC held for 1 minute (first part of testing of the complete web lashing)

The last part of the testing of the complete web lashing, tests of strength, showed that a force at break was different for the samples tested with  $1\frac{1}{4}$  and  $2\frac{1}{4}$  turns of winding in ratchet. This difference was caused mainly due to damages on webbing of the samples tested with  $1\frac{1}{4}$  turns of winding, which had occurred during previous cyclic loading tests (Fig. 3) while the samples tested with  $2\frac{1}{4}$  turns of winding were tested almost undamaged. But a quantity of winding in a ratchet also affects the strength of straps (force at break) because a place near a rotating axis of ratchet, where a winding ends, is a typical place of break of sufficient-quality and undamaged straps. When a low quantity of winding is wrapped around rotating axis, the split pin can act as a sharp edge when a high force acts on a strap. Also if an end fitting of a lashing strap has sharp edges like some of flat hooks, these edges may become the weakest part of the complete lashing strap, because the webbing may break just on these edges. Therefore, using of such end hooks is wrong in general [1].

In our case, all the straps and ratchets made by producer A complied with the requirements of the standard EN 12 195-2, if they were tested with  $2\frac{1}{4}$  turns of winding in ratchet and have not been damaged before the strength tests. But only one out of four samples of the same producer passed the test requirements with  $1\frac{1}{4}$  turns of winding. The other three samples had lowered strength to 1.42 - 1.69 LC (71 - 84.5% of the level prescribed by the standard) due to damaged edges of webbing. The straps and ratchets of other producers were tested only with  $2\frac{1}{4}$  turns of winding in ratchet.

An interesting situation occurred with the straps made by producer B. These straps did not become damaged (neither on edges) during the cyclic loading tests performed with  $1\frac{1}{4}$  turns of winding despite of excessive elongation (pulling out from ratchet). But a dangerous problem occurred on one of the fixed ends. The fixed end BFL1 was used for two tests, firstly with the loose end BL1 of the same producer (the webbing of this loose end broke at the force 4 793 daN). Subsequently the fixed end was tested with the loose end CL3 by other producer

<sup>6</sup>Difference between the elongation when a force equivalent to 1.25 LC was reached and the elongation after a minute of holding this force.

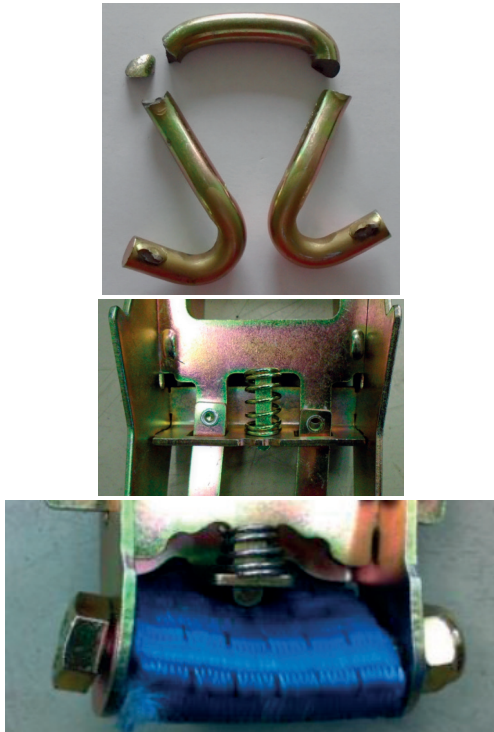

Source: Authors

Fig. 5 Broken end hook of the fixed end BFL1 before the force equivalent to double LC was reached (up on the left) and damages on the fixed end BFL2 - outage of rivet (up on the right) and bowed screw (down)

and the end hook of the fixed end BFL1 was completely broken into 4 parts at this test at the force 4 724 daN, yet under required level of 2 LC. Another fixed end BFL2 met the test requirements, but it became also the weakest part of the tested combination with the strap of other producer CL4. The ratchet broke and one of the rivets fell away, and as

a consequence of this, this tensioning ratchet was no longer usable due to dysfunctional releasing device. In addition to this, a screw holding the fixed end of the strap webbing was markedly bowed after the test. These damages are shown in Fig. 5.

The diagram in Fig. 6 shows a run of force and elongation of the selected samples of complete lashing straps during the strength tests (the final part of testing of the complete web lashing). The strap of the above stated sample BFL1/BL1 with the force at break 4 793 daN have been gradually breaking yet by the force 3 000 daN.

## 6. Conclusion

These tests confirm the importance of quantity of winding in a ratchet when lashing straps are used. Results of the tests clearly prove that if the quantity of winding in ratchet is too low, the lashing straps fail in the cyclic loading tests, where they elongate abnormally (our samples exceeded the maximum allowed elongation according to the standard EN 12 195-2 by 53 - 663 %), derail from the tensioning ratchet and edges of their webbing are being damaged in contact with ratchet edges. Therefore, too low quantity of winding contributes not only to lowering durability of lashing straps, but also to safety risks resulting from the possibility of loss the securing capability of the straps in case such repetitive load occurs during transport. It may result in damages of transported cargo and in worst cases also to traffic safety.

The tests also showed that if the short ratchets are used, the elongation of the complete lashing straps under load is higher in comparison with cases when long ratchets are used. We also must say that two out of the eight tested ratchets had severe quality problems, where the split pin of the ratchet AFL3

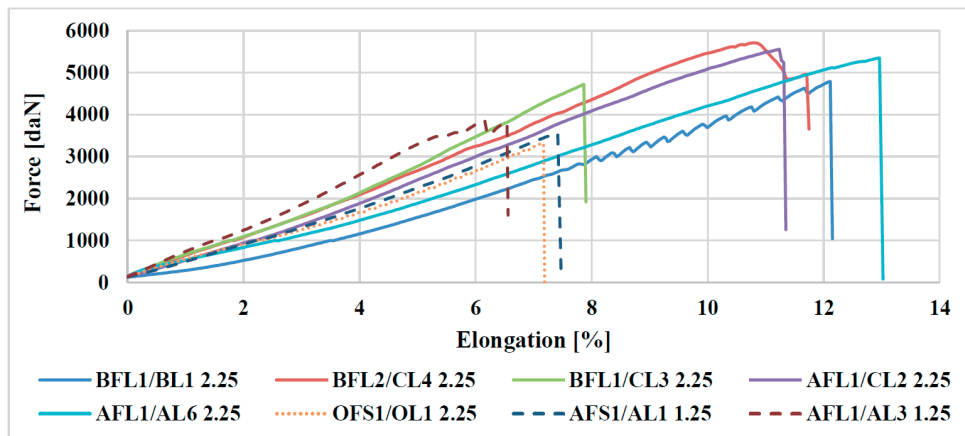

Source: Authors

Fig. 6 Run of the force and elongation of selected straps during the strength tests (samples with "1.25" in legend were tested with 1/4 turns of winding in a ratchet and those with "2.25" were tested with 2/4 turns of winding in a ratchet)

broke already during the first cycle of cyclic loading tests at force 1 473 daN (significantly below the lashing capacity) and the end hook of the ratchet BFL1 was broken into 4 parts at force 4 724 daN. Next ratchet BFL2 was also the weakest part of tested combination, although it met the test requirements, because the partial break occurred upon the level of 2 LC. However, the usual type of break of the complete lashing strap is a break of webbing loose end, near the ratchets rotating axis, where a winding ends. Results of the tests point at the fact that for good securing of cargo in practice it is needed to pay attention to a quality of used tensioning devices and end fittings, as well as to correct quantity of winding of a strap in tensioning ratchets, because these factors significantly affect the characteristics of lashing straps.

### Acknowledgement

This publication is the result of the project implementation: Centre of excellence for systems and services of intelligent transport, ITMS 26220120028 supported by the Research & Development Operational Programme funded by the ERDF.



“We support research activities in Slovakia / This project is co-financed by the European Union”

### References

- [1] JAGELCAK, J.: Reduction of Lashing Strap Strength (in Slovak). *Truck & Business: Magazine for Road Transport Enterprise Strategy*, vol. 8, No. 2, 2015, 58-59, ISSN 1337-897X.
- [2] ZAMECNIK, J., JAGELCAK, J., SOKJER-PETERSSSEN, S.: Comparison of Acceleration Acting on Cargo in Front and in Rear Part of Semi-Trailer during Braking with and without using the Systems ABS/EBS, *Communications - Scientific Letters of the University of Zilina*, vol. 18, No. 2, 2016, 76-82, ISSN 1335-4205.
- [3] ZAMECNIK, J., JAGELCAK, J.: The Stress of Lashing Points in Full-Loaded 3.5-Tonne Van During Emergency Braking. *Logi: Scientific J. on Transport and Logistics*, vol. 6, No. 1 2015, 136-152, ISSN 1804-3216.
- [4] POLIAK, M., KOMACKOVA, L., SEMANOVA, S., HERNANDEZ, S., JASKIEWICZ, M.: Defining the Influence of the Support of Bus Service on Road Safety, *Communications - Scientific Letters of the University of Zilina*, vol. 18, No. 2, 2016, 83-87, ISSN 1335-4205.
- [5] JAGELCAK, J., ZAMECNIK, J.: Quality and Testing of Lashing Straps (in Slovak). *Truck & Business: Magazine for Road Transport Enterprise Strategy*, vol. 8, No. 4, 2015, 72-75, ISSN 1337-897X.
- [6] EN 12 195-2:2000. Load Restraint Assemblies on Road Vehicles. Safety, Part 2: Web lashing made from man-made fibres, 2000
- [7] KUBANOVA, J., SCHMIDT, C.: Multimodal and Intermodal Transportation Systems, *Communications - Scientific Letters of the University of Zilina*, vol. 18, No. 2, 2016, 104-109, ISSN 1335-4205.
- [8] IMO/ILO/UNECE Code of Practice for Packing of Cargo Transport Units (CTU Code), 2014
- [9] JAGELCAK, J.: *Loading and Securing of Cargo in Road Transport* (in Slovak), EDIS : University of Zilina, 2015, ISBN 978-80-554-1083-8.
- [10] HVOJNIK, T.: *Cyclic Loading Tests of Selected Lashing Straps According to the Standard EN 12 195-2* (in Slovak), Bachelor thesis (supervisor J. Jagelcak, reviewer J. Zamecnik), Zilina, 2016
- [11] LIPKA, M.: *Strength Tests of Selected Lashing Straps According to the Standard EN 12 195-2* (in Slovak), Bachelor thesis (supervisor J. Jagelcak, reviewer J. Zamecnik), Zilina, 2016.

Ondrej Stopka - Branislav Sarkan - Maria Chovancova - Larisa M. Kapustina\*

## DETERMINATION OF THE APPROPRIATE VEHICLE OPERATING IN PARTICULAR URBAN TRAFFIC CONDITIONS

*This paper presents selection of the most appropriate vehicle intended to operate on a particular urban territory, using the specific methods of multi-criteria analysis. For selecting the suitable vehicle, it is necessary to determine a number of specific criteria. In the paper, the desired vehicle is selected from five vehicles, while, each of them has a different product brand. To determine the weights of criteria, the Saaty pairwise comparison method is applied, and subsequently, the multi-criteria evaluation of alternatives is utilized for a research problem.*

**Keywords:** Operation, supply, urban traffic, City logistics, vehicle, decision-making.

### 1. Introduction

Utility vehicle, i.e. vehicle used for the cargo supply in urban area, is an important factor and limitation for the customers' services in regard to the urban style of the city, city built-up area, the deployment of customers, etc. Generally, customers or distribution centers do not have any specific requirements for the transport means and are supplied by conventional freight vehicles.

However, each of the vehicles has distinct fuel consumption and their individual parameters differ. The deployment of the optimal vehicle can significantly facilitate the activities of the supply in a given territory. Thus, determining the appropriate vehicle for operating in a particular territory in the context of City logistics undoubtedly represents an essential aspect for individual enterprises [1 - 3].

### 2. Issues of decision-making

Determination of the weights and making the subsequent multi-criteria evaluation of alternatives can be considered to be a decision-making issue in which the final result is influenced by a group of external aspects [4 and 5].

For the purpose of solving the decision-making issues, the individual methods of multi-criteria analysis may be utilized [6, 7 and 8]. It is important to have a list of alternatives from which to select. Cases where a clearly defined list of potential

alternatives is known are more or less the exception than the rule [7 and 9].

General procedure for the multi-criteria evaluation of alternatives includes six basic phases: (1) Identification of alternatives, (2) Determination of the specific criteria, (3) Determination of the weights of criteria, (4) Determination of the criteria examples, (5) Partial evaluation of alternatives and (6) Selection of the most appropriate alternative.

The analysis of existing methods utilized for dealing with the multi-criteria analysis has been carried out. Some of these methods do not take into consideration the weights of criteria. And since, among the criteria which influence the individual factors of the multi-criteria evaluation of alternatives, significant distinctions in the importance of criteria exist, these methods are not suitable for our particular research problem [7 and 10 - 14].

#### 2.1. Methods for determination of the weights of criteria

Methods for determining the weights (see Table 1) can be divided according to the information that we have about the criteria significance [5 - 8, 13 and 14]:

- no information,
- ordinal information,
- cardinal information.

\* <sup>1</sup>Ondrej Stopka, <sup>2</sup>Branislav Sarkan, <sup>3</sup>Maria Chovancova, <sup>4</sup>Larisa M. Kapustina

<sup>1</sup>Department of Transport and Logistics, Faculty of Technology, Institute of Technology and Business in Ceske Budejovice, Czech Republic

<sup>2</sup>Department of Road and Urban Transport, Faculty of Operation and Economics of Transport and Communications, University of Zilina, Slovakia

<sup>3</sup>Department of Railway Transport, Faculty of Operation and Economics of Transport and Communications, University of Zilina, Slovakia

<sup>4</sup>Ural State University of Economics, Yekaterinburg, Russia

E-mail: stopka@mail.vstecb.cz

No information - The researchers are not able to decide about the level of significance of the criteria. It is supposed that there is a criteria matrix quantified by the cardinal values.

Ordinal information - These methods suppose that the researcher may express the significance of each criterion by assigning to all criteria their special numbers or when comparing all criteria pairs, they may decide which criterion, from the current pair, is more important compared to another. In both cases, it is permissible to determine two or more criteria as equal.

Cardinal information - These methods suppose that the researcher may not only determine the order of criteria significance, but also the significance of the relationships among all criteria.

Methods for determination of the weights of criteria Table 1

| Information about significance among the criteria pairs |                     |                      |
|---|---------------------|----------------------|
| No information  | Ordinal information | Cardinal information |
| Method of equal weights                                 | Method of ranking   | Scoring method       |
| Entropy method  | Fuller method       | Saaty method         |

Source: [10]

## 2.2. Methods for the multi-criteria evaluation of alternatives

Methods for the multi-criteria evaluation of alternatives (selection of the most suitable alternative) are divided according to the information about the significance between the criteria pairs that is required. The information may be [5 and 10]:

- maximizing the benefits,
- minimizing the distance from the ideal variant,
- regarding the preferential relationship.

Specific methods for the multi-criteria evaluation of alternatives include: Simple method of scoring or Simple method of ranking, Lexicographical method, Permutation method, ORESTE method, TOPSIS method, Weighted Sum

Approach - WSA method, Analytic Hierarchy Process - AHP method, Entropy method and many others [5 and 8 - 11].

## 3. Research problem and outcomes

This part of the paper deals with the research problem and obtained outcomes, i.e., the shortened and modified version of the general procedure for multi-criteria evaluation of alternatives. This version specifically consists of: (1) Determination of the specific criteria, (2) Identification of alternatives, (3) Determination of the weights of criteria and (4) Selection of the most appropriate alternative.

### 3.1. Determination of the specific criteria

Phase one of our modified procedure of multi-criteria evaluation of alternatives includes the decision about the specific criteria which influence the final evaluation process [8, 9 and 12].

Among the specific criteria regarding the selection of the most appropriate vehicle for the cargo supply in urban area, five of them, primarily due to the vehicles utility purposes, were defined. For these criteria, required data, concerning the parameters of further identified alternatives, were obtained [10 and 13].

For the purpose of the appropriate vehicle selection, the following criteria were therefore included: *K1* - the fuel consumption (engine diesel) of the vehicle in the city (l / 100km), *K2* - the price of the vehicle (CZK), *K3* - the vehicle loading length (mm), *K4* - the cargo space volume of the vehicle (m<sup>3</sup>) and *K5* - the gross vehicle weight (kg).

### 3.2. Identification of alternatives

Among the selected alternatives (utility vehicles - *Di*), commonly used means of transport for operation on the city territory produced by different manufacturers may be

Identified alternatives (vehicles) with respect to the specific criteria Table 2

| Criteria ( <i>Ki</i> ) \ Vehicle ( <i>Di</i> ) | <i>K1</i> - Fuel consumption (l/100 km) | <i>K2</i> - Price (CZK) | <i>K3</i> - Length (mm) | <i>K4</i> - Cargo space volume (m <sup>3</sup> ) | <i>K5</i> - Gross weight (kg) |
|--|---|-------------------------|-------------------------|--|-------------------------------|
| D1   | 9.1                                     | 489 900                 | 5 048                   | 10.80  | 2 950                         |
| D2   | 7.8                                     | 328 000                 | 3 450                   | 7.05   | 1 970                         |
| D3   | 8.5                                     | 724 200                 | 5 998                   | 14.00  | 3 223                         |
| D4   | 9.5                                     | 505 000                 | 3 250                   | 9.50   | 2 810                         |
| D5   | 13.5                                    | 547 676                 | 3 400                   | 8.70   | 2 087                         |

Source: authors

included. For the purpose of this paper, the following vehicles are chosen and with respect to the above-identified criteria, are characterized in the subsequent table (see Table 2): *D1* - Vehicle 1, *D2* - Vehicle 2, *D3* - Vehicle 3, *D4* - Vehicle 4 and *D5* - Vehicle 5.

**3.3. Determination of the weights of criteria using the particular method**

To determine the weights of criteria, *Saaty pairwise comparison method* was selected. A number of specific criteria have lesser or greater effect on vehicle determination. Thus, it was important to select such a method which enables the expert’s judgment in order to decide about the relationship of significance among the criteria pairs. Furthermore, Saaty method enables the detailed distribution of these significances [12 - 14].

For the evaluation of the relationship of significance among the criteria pairs, Saaty method a nine point scale utilizes [5, 6 and 13]. 1 - equal criteria *i* and *j*, 3 - slightly preferred criterion *i* above *j*, 5 - strongly preferred criterion *i* above *j*, 7 - very strongly preferred criterion *i* above *j*, 9 - absolutely preferred criterion *i* above *j* [5, 6 and 13].

It is possible to use intermediate values (2, 4, 6, 8) as well. Matrix elements  $S = (s_{ij})$  are interpreted as estimates of the fraction of the weights of the *i*-th and *j*-th criteria. The expert compares each pair of the criteria and writes the significance values of *i*-th in the relation to the *j*-th criterion in the Saaty matrix  $S = (s_{ij})$ . In case that *j*-th criterion is preferred above the *i*-th criterion, inverse values are written in the Saaty matrix ( $s_{ij} = 1/3$  for low preference,  $s_{ij} = 1/5$  for strong preference, etc.) [10, 15 and 16].

Weight vector values are denoted as  $v = (v_1, v_2, \dots, v_k)$ . The normalized geometric mean represents the most preferred method of the weight calculation. This process is generally called “logarithmic least squares method [14 - 16].” The normalized weights are calculated for each criterion when utilizing the geometric mean of each row in the matrix divided by the sum of the geometric means of all the criteria [10 and 14].

Calculation of the geometric mean of each row of the matrix *S* is expressed in the following formula (1):

$$g_i = \sqrt[k]{\prod_{j=1}^k s_{ij}} \dots \dots i, j = 1, 2, \dots, k \tag{1}$$

where  $g_i$  is the geometric mean;  $s_{ij}$  are elements of Saaty matrix;  $\prod$  represents the product of values of Saaty matrix elements.

Normalization of the geometric mean is shown in the formula (2):

$$v_i = \frac{g_i}{\sum_{i=1}^k g_i} \dots \dots i, j = 1, 2, \dots, k \tag{2}$$

where  $v_i$  is the normalized (weighted) geometric mean,  $g_i$  is the geometric mean,  $\sum$  represents the sum of geometric mean values.

The individual values of the weights of criteria are summarized in Table 3.

Completed Saaty matrix (table) Table 3

| Criteria ( <i>Ki</i> ) | K1  | K2  | K3  | K4  | K5 |
|------------------------|-----|-----|-----|-----|----|
| Criteria ( <i>Ki</i> ) |     |     |     |     |    |
| <i>K1</i>              | 1   | 3   | 5   | 1/2 | 5  |
| <i>K2</i>              | 1/3 | 1   | 4   | 1/3 | 7  |
| <i>K3</i>              | 1/5 | 1/4 | 1   | 1/7 | 7  |
| <i>K4</i>              | 2   | 3   | 7   | 1   | 9  |
| <i>K5</i>              | 1/5 | 1/7 | 1/7 | 1/9 | 1  |

Source: authors

Subsequently, individual values of the Saaty method were utilized for further calculations. The values obtained for the individual criteria in the intermediate calculations and the resulting values of the weighted geometric mean are shown in Table 4.

Values calculated by the Saaty method Table 4

| Criterion | Multiples of preferences | Geometric mean ( $g_i$ ) | Weighted geometric mean ( $v_i$ ) |
|-----------|--------------------------|--------------------------|-----------------------------------|
| <i>K1</i> | 37.5000                  | 2.0640                   | 0.2810                            |
| <i>K2</i> | 3.1110                   | 1.2550                   | 0.1710                            |
| <i>K3</i> | 0.0500                   | 0.5490                   | 0.0750                            |
| <i>K4</i> | 3780.0000                | 3.2770                   | 0.4460                            |
| <i>K5</i> | 0.0004                   | 0.2090                   | 0.0270                            |
| $\sum$    | 418.6614                 | 7.3540                   | 1.0000                            |

Source: authors

**3.4. Selection of the most appropriate alternative using the particular method**

There are a lot of distinct methods to solve the multi-criteria evaluation issues that can be utilized for the matter of particular alternative selection. However, a significant number of them cannot be applied, since they do not allow taking into consideration the entire complexity of these issues.

From the foregoing, it was decided to apply the Weighted Sum Approach method - WSA, which is suitable for the comprehensive issue of vehicle choice. The WSA method requires cardinal information, criteria matrix *Y* and criteria weight vector *v*.

The WSA method is able to create the overall rating for each of the alternatives and therefore, it can be utilized for selecting the most appropriate vehicle as well as for scaling the vehicles from best to worst [10, 14 and 17].

Regarding this method, the weight of each criterion, i.e.  $s_v = (v_1, v_2, \dots, v_k)$  for  $k$  of maximization criteria, is taken into consideration.

The WSA method then maximizes the weighted sum (see formula 3):

$$u(A_i) = \sum_{j=1}^k v_j r_{ij} \tag{3}$$

where  $u(A_i)$  is the aggregated utility function for each alternative,  $v_j$  is the criteria weight vector (normalized geometric mean),  $r_{ij}$  are the elements of the normalized criteria matrix. Hence, the value of the weighted sum for each alternative can be calculated and as a compromise alternative, the particular one with the greatest weighted sum can be selected [10, 11 and 18].

In the next step, it is necessary to create the criteria matrix. The rows of the criteria matrix are formed by the individual alternatives. The columns of the criteria matrix correspond to the individual criteria. In our case, the criteria matrix looks the same as Table 2.

Subsequently, it is inevitable to carry out the following steps:

- 1) Transformation of the criteria to the same type - it is important for all the criteria to be of the same type (minimization or maximization) [10 and 16].

- 2) Ideal and basal alternative - ideal alternative is the best option which may be practically achieved and basal alternative represents the worst possible alternative [5, 17 and 18].

- 3) Criteria matrix normalization - if the ideal and basal alternatives are known, the normalization of the criteria matrix may be simply carried out. In the criteria matrix, all the values are in the interval  $\langle 0, 1 \rangle$ , the ideal value of the criteria matrix is represented by the number 1 and the basal by the number 0. A lot of studies on criteria matrix normalization are shown, for instance, in literature [5, 6, 11 and 19].

After creating the normalized criteria matrix, the aggregated utility function for each alternative " $u(A_i)$ " is calculated and alternatives are ranked from best to worst (see Table 5) [7 - 9, 20 - 22].

#### 4. Conclusions

After completing the Saaty method, the greatest weight was assigned to the cargo space volume and the fuel consumption of the particular utility vehicle. After creating the criteria matrix with regard to the multi-criteria evaluation of alternatives, the individual vehicles were ranked from best to worst.

And therefore, on the basis of performed calculations, it may be concluded that the optimal vehicle type for cargo supply in particular urban traffic conditions seems to be an **alternative D3**. On the other hand, alternative D5 appears to be the least suitable selection that has the high fuel consumption and, compared to alternative D3 has insufficient cargo space volume [20 and 23].

Achieved results

Table 5

| Alternative \ Criterion | K1    | K2    | K3    | K4    | K5    | $u(A_i)$ | Order     |
|-------------------------|-------|-------|-------|-------|-------|----------|-----------|
| D1                      | 0.772 | 0.591 | 0.654 | 0.540 | 0.218 | 0.614    | 2.        |
| D2                      | 1.000 | 1.000 | 0.073 | 0.000 | 1.000 | 0.484    | 3.        |
| D3                      | 0.877 | 0.000 | 1.000 | 1.000 | 0.000 | 0.767    | <b>1.</b> |
| D4                      | 0.702 | 0.553 | 0.000 | 0.353 | 0.330 | 0.458    | 4.        |
| D5                      | 0.000 | 0.445 | 0.055 | 0.237 | 0.907 | 0.210    | 5.        |
| Weightings              | 0.281 | 0.171 | 0.075 | 0.446 | 0.027 |          |           |

Source: authors

#### References

[1] BARATTA, V., FISCHER, M., WELTALMANACH, D.: *Fischer Taschenbuch Verlag*, Frankfurt am Main, 2001, ISBN 97-83596-10385-0.  
 [2] FAZEKAS, M.: *City Logistics, PhD Progress*, University of Zilina, vol. 1, No. 2, 2013, 41-47, ISSN 1339-1712.

- [3] LIZBETINOVA, L., KAMPF, R., LIZBETIN, J.: Requirements of a Transport System User, *Communications - Scientific Letters of the University of Zilina*, vol. 14, No. 4, 2012, 106-108, ISSN 1335-4205.
- [4] FAZEKAS, M., KUBASAKOVA, I., SULGAN, M.: *Proposal of the City Logistics Solutions and Concepts for the City of Zilina*, Logistics - Economy - Practice 2013, reviewed proc. of the 2<sup>nd</sup> intern. Scientific conference, Zilina, 2013, 49-55, ISSN 1336-5851.
- [5] JURKOVIC, M., SOSEDOVA, J.: Simulation Process of Optimal Transport Department Regarding to Transport Vehicles Based on AHP Method - Applied to Slovakia, *Asian J. of Engineering and Technology*, vol. 1, No. 4, 2013, 124-128, ISSN 2321-2462.
- [6] ZOPOUNIDIS, C., PARDALOS, P.M.: *Handbook of Multicriteria Analysis: Applied Optimization*, vol. 103, 2010, Springer-Verlag Berlin: Heidelberg.
- [7] EDWARDS, W.: The Theory of Decision Making, *Psychological Bulletin*, vol. 51, No. 4, 1954, 380-417.
- [8] JABLONSKY, J.: *Operations Research: Quantitative Models for Economic Decision Making*, 3<sup>rd</sup> ed., Professional Publishing : Prague, 2007, 323 p.
- [9] ANDERSON, D. R., SWEENEY, D. J., WILLIAMS, T. A., CAMM, J. D., KIPP MARTIN, R.: *An Introduction to Management Science: Quantitative Approaches to Decision Making*, South-Western College Pub., 2010, 1045 p.
- [10] KALINA, T., JURKOVIC, M., BINOVA, H., GARDLO, B.: Water Transport - The Challenge for the Automotive Industry in Slovakia, *Communications - Scientific Letters of the University of Zilina*, vol. 18, No. 2, 2016, 26-29, ISSN 1335-4205.
- [11] KEENEY, R., RAIFFA, H.: *Decisions with Multiple Objectives, Preferences and Value Trade-offs*, Cambridge University Press : Cambridge & New York, 1976, 569 p.
- [12] SAATY, T. L., VARGAS, L. G., WENDELL, R. E.: Assessing Attribute Weights by Ratios, *Omega - The Intern. J. of Management Science*, vol. 2, No. 1, 1983, 9-13.
- [13] LIZBETIN, J., CERNA, L., LOCH, M.: Model Evaluation of Suppliers in Terms of Real Company for Selected Criteria, *Nase More*, vol. 62, No. 3, 2015, 147-152. ISSN 0469-6255.
- [14] SAATY, T. L.: *Priority Setting in Complex Problems*, Hansen, P. (Hrg.), Essays and Surveys on Multiple Criteria Decision Making. Proc. of the Fifth International Conference on Multiple Criteria Decision Making. Berlin : Heidelberg : NewYork : Springer-Verlag, 1983, 441 p.
- [15] KAMPF, R., PRUSA, P., SAVAGE, C.: Systematic Location of the Public Logistic Centres in Czech Republic, *Transport*, vol. 26, No. 4, 2011, 425-432, ISSN 1648-4142.
- [16] HRUSKA, R., PRUSA, P., BABIC, D.: The use of AHP Method for Selection of Supplier, *Transport*, vol. 29, No. 2, 2014, 195-203, ISSN 1648-4142.
- [17] CABAN, J., DROZDZIEL, P., BARTA, D., LISCAK, S.: Vehicle Tire Pressure Monitoring Systems, *Diagnostyka*, vol. 15, No. 3, 2014, 11-14, ISSN 1641-6414.
- [18] MALINDZAKOVA, M.: Significance Evaluation of Environmental Aspects, *Communications - Scientific Letters of the University of Zilina*, vol. 13, No. 3, 2011, 48-51, ISSN 1335-4205.
- [19] SKRUCANY, T., SARKAN, B., GNAP, J.: Influence of Aerodynamic Trailer Devices on Drag Reduction Measured in a Wind Tunnel, *Eksploatacja i niezawodnosc/Maintenance and Reliability*, vol. 18, No. 1, 2016, 151-154, ISSN 1507-2711.
- [20] FEDORKO, G., ROŠOVA, A., MOLNAR, V.: The Application of Computer Simulation in Solving Traffic Problems. *The Urban Traffic Management in Slovakia, Theor. Empir. Res. Urban Management*, vol. 9, 2014, 5-17.
- [21] ZITRICKY, V., GASPARIK, J., PECENY, L.: The Methodology of Rating Quality Standards in the Regional Passenger Transport, *Transport Problems*, vol. 10, 2015, 59-72, ISSN 1896-0596.
- [22] POLIAKOVA, B.: Integrated Transport System Nodes and their Impact on the Increasing of Passenger Safety, *Automotive Safety 2014: Problemy bezpečenstwa w pojazdach samochodowych: IX intern. science-technical conference : Rajecke Teplice : Kielce : Wydawnictwo Politechniki Swietokrzyskiej*, 2014, 321-326, ISBN 978-83-63792-21-3.
- [23] RHYS-TYLER, G. A., LEGASSICK, W., BELL, M. C.: The Significance of Vehicle Emissions Standards for Levels of Exhaust Pollution from Light Vehicles. *An Urban Area, Atmospheric Environment*, vol. 45, No. 19, 2011, 3286-3293, DOI:10.1016/j.atmosenv.2011.03.035.

Frantisek Brumercik – Michal Lukac – Zbigniew Krzysiak – Leszek Krzywonos\*

## MODEL OF INTEGRATED TRANSPORTATION SYSTEM

*The article presents the possibilities of an integrated transport system modeling simulating the complexity of regional transportation and its effects. The modeling methods deal with individual behavioral units and proceed through several steps to estimate travel.*

**Keywords:** Modeling, simulation, regional transportation, hybrid model.

### 1. Introduction

The possibilities of the simulations in the transportation area are quite huge. The main objective is usually to develop a set of mutually supporting realistic simulations, models and data bases that employ advanced computational and analytical techniques to create an integrated regional transportation systems analysis environment.

### 2. Model concept description

The modeling methods deal with individual behavioral units and proceed through several steps to estimate travel. The system predicts trips for individual households, residents, freight loads, and vehicles rather than for zonal aggregations of households.

The Household and Commercial Activity Disaggregation Module creates regional synthetic populations from census and other data. Using activity-based methods and other techniques, it produces a travel representation of each household and traveler.

The Intermodal Route Planner involves using a demographically defined travel cost decision model particular to each traveler. Vehicle and mode availability are represented and mode choice decisions are made during route plan generation [1]. The method estimates desired trips not made, induced travel, and peak load spreading. This allows evaluation of different transportation control measures and travel demand measures on trip planning behaviors.

The Travel Microsimulation executes the generated trips on the transportation network to predict the performance of

individual vehicles and the transportation system. It attempts to execute every individual's travel itinerary in the region. For example, every passenger vehicle has a driver whose driving logic attempts to execute the plan, accelerates or decelerates the car, or passes as appropriate in traffic on the roadway network. The Travel Microsimulation produces traffic information for the Environmental Models and Simulations to estimate motor vehicle fuel use, emissions, dispersion, transport, air chemistry, meteorology, visibility, and resultant air quality [2]. The emissions model accounts for both moving and stationary vehicles. The regional meteorological model for atmospheric circulation is supplemented by a model for local effects. The dispersion model is used for directly emitted contaminants and handles both local and urban scale problems. The air chemistry model includes dispersion, but is designed to deal with secondary pollutant production on larger scales.

### 3. Household and commercial activity disaggregation module

The Household and Commercial Activity Disaggregation (HCAD) Module contains two submodules, Synthetic Populations and Activity Demand and Travel Behavior.

#### 3.1 Synthetic Population submodule

The Synthetic Population submodule creates a regional population imitation whose demographics closely match that of the real population. The imitation households also are

\* <sup>1</sup>Frantisek Brumercik, <sup>1</sup>Michal Lukac, <sup>2</sup>Zbigniew Krzysiak, <sup>3</sup>Leszek Krzywonos

<sup>1</sup>Mechanical Engineering Faculty, University of Zilina, Slovakia

<sup>2</sup>University of Life Science in Lublin, Faculty of Production Engineering, Poland

<sup>3</sup>Lublin University of Technology, Faculty of Mechanical Engineering, Poland

E-mail: brumercikf@fstroj.uniza.sk

distributed spatially to approximate the regional population distribution. The synthetic population demographics are provided to the Activity Demand submodule to derive individual and household activities requiring travel. The household locations determine travel origins and destinations [3].

The underlying theme of represented simulation concept is that individual behavior and their interactions, as constrained by the transportation system, generate the transportation system performance. To affect that performance in a transportation system simulation, individual behavior must be modeled. The Synthetic Population submodule begins the process of creating those “individual” models.

Figure 1 shows the agent based population model based on Geographical information Science (GIS) data.

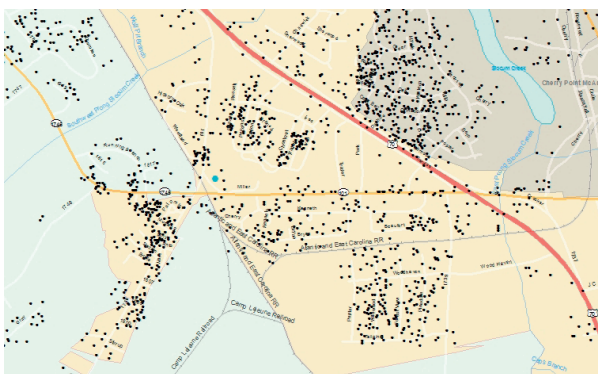

Fig. 1 Agent based population model based on GIS data (Source: [4])

### 3.2 Activity Demand and Travel Behavior submodule

The purpose of the Household and Commercial Activity Disaggregation and Activity Demand submodule is to generate household activities, activity priorities, activity locations, activity times, and mode and travel preferences. The activities and preferences are functions of the household demographics created by the Synthetic Population submodule. The Intermodal Route Planner uses the activities and preferences to determine individual and load trip plans for the region [5 and 6].

Households and businesses have activities that must be, or are desired to be, performed during the day. Many of these activities require the transportation system to move a load (individual or freight) to a certain place at a certain time. Thus, activity demand generates travel demand. These activities and how they are performed depend on the demographics of the household and its individuals, or on the nature of the business. In the presented simulation concept the interest is focused on traveler activities; modeling commercial load activities will be difficult until more data is available on shipping

[7]. Traveler activities are aggregated at a low level into household activities. Household activities then are estimated from probability distributions dependent on the household demographics. These demographics include the ages of the inhabitants, the household family type (single, married couple, married couple with small children, married couple with older children, etc.), the household income, the number of cars on the household and the members of the household who can drive. These demographics are produced by the Synthetic Population submodule.

The main feedback mechanism from traffic behavior Dynamic Traffic Assignment (DTA) to an activity-based model (ABM) is the so-called skim matrices, which are the zone-to-zone (or parcel-to-parcel or location-to-location) travel times informed by the traffic simulation model (Fig. 2).

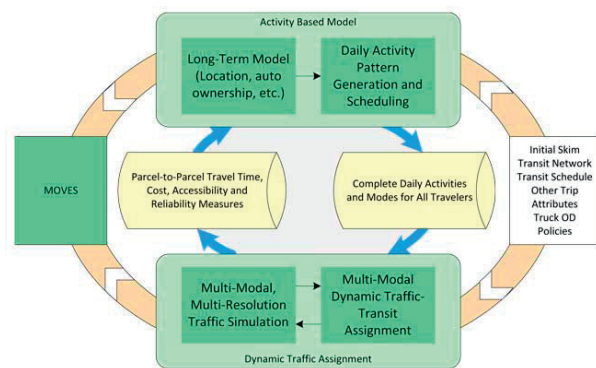

Fig. 2 Feedback mechanism between DTA and ABM (Source: [8])

### 4. Intermodal route planner

The Intermodal Route Planner generates regional individual activity-based travel demand.

A “load” is a traveler or a commodity. A trip plan is a sequence of modes, routes, and planned departure and arrival times at the origin, destination(s), and mode changing facilities projected to move the load to its activity locations. It is assumed that travel demand is derived from a load’s desire or need to perform activities. The HCAD provides the Planner with disaggregated activity demand and travel behavior. The Planner assigns activities, modes, and routes to individual loads in the form of trip plans [9]. The individual trip plans are input to the Travel Microsimulation for its analysis. Trip plan selection is related directly to a load’s desire to satisfy individual (or in the case of freight, corporate) goals. Goals measure a trip plan’s acceptability and depend on the load’s socioeconomic attributes and trip purpose. Typical goals include cost, time, and distance minimization and safety and security maximization. The load’s objective is to minimize the deviations from these goals.

Mode and route preferences also are important in the Planner. A preference is the inherent partiality or bias a load has for a particular mode or route. Typical preferences include departure time, origin-destination directedness and congestion avoidance. These preferences reduce the Planner's (activity, mode and route) solution space and offer significant computational savings.

The graphic of an intermodal route planner for East-West Corridor is shown in Fig. 3.



Fig. 3 Graphic of an intermodal route planner for East-West Corridor (Source: [10])

### 5. Travel microsimulation

The Travel Microsimulation module mimics the movement and interactions of travelers throughout a metropolitan region's transportation system. For this discussion, traveler refers both to human travelers as well as freight loads, etc. The Intermodal Route Planner provides a trip plan to each traveler that he then attempts to execute on the transportation network. In the process he interacts with other travelers and the transportation system. The combined traveler interactions produce emergent behaviors such as traffic congestion.

The Travel Microsimulation models many transportation modes including automobiles, trucks, buses, light rail, commuter rail, bicycles, and pedestrians. Thus, the microsimulation includes roadway, transit, rail, bikeway, and pedestrian networks. In the following discussion, the microsimulation is illustrated with roadway transportation examples because of its high use, complexity, and importance to air quality.

The roadway network includes freeways, highways, streets, ramps, turn lanes, grades, and intersections (signalized or non-signalized). In executing their trip plans, vehicle drivers accelerate, decelerate, turn, change lanes, pass, and respond to other vehicles and signs and signals. Drivers exhibit behavior between aggressive and passive. Vehicles have weight and acceleration and deceleration characteristics [11].

Analysis requirements determine the necessary microsimulation detail. Increasing the microsimulation detail increases its behavioral representation of real transportation

systems, but it also increases its computational burden. The representation quality is called the model's fidelity. One goal is to find the minimum computational detail necessary to produce the fidelity needed for specific analyses. This minimum computational detail is also called critical complexity. A hybrid technique uses high-fidelity microsimulations for areas where detailed results are needed and low-fidelity, fast-running microsimulations for areas where there is less interest. This hybrid microsimulation requires matching the microsimulations at their boundaries. The flowchart of the classic approach to the travel microsimulation is shown in Fig. 4.

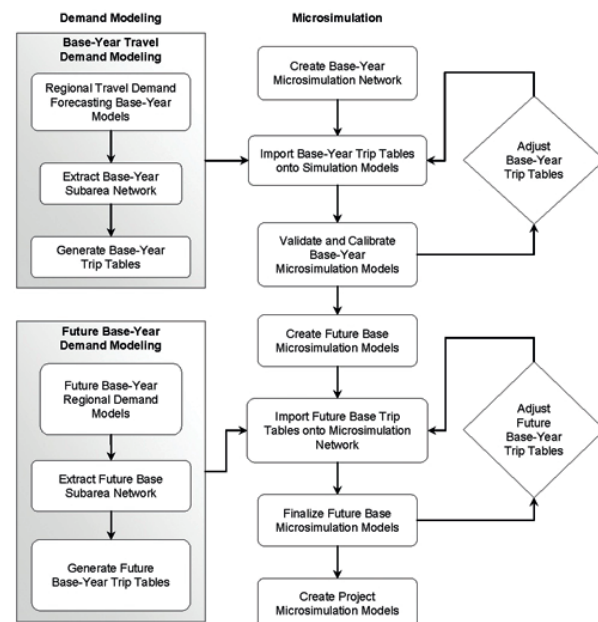

Fig. 4 Flowchart of the classic approach to travel microsimulation (Source: [12])

### 6. Environmental models and simulation

The purpose of the environmental module is to translate traveler behavior into consequent air quality, energy consumption, and carbon dioxide emissions. The environmental module will use information from the planner and the microsimulation and it will support the analyst's toolbox. It also could provide information on fog to the microsimulation.

Transportation systems play a significant role in urban air quality, energy consumption and carbon-dioxide emissions. Recently, it has been found that current systems for estimating emissions of pollutants from transportation devices lead to significant inaccuracies. When these inaccuracies are coupled to air quality models and limited meteorological data, it is difficult to tell whether the most appropriate path is being

taken to achieve air quality goals. Most existing emission modules use very aggregate representations of traveler behavior and attempt to estimate emissions on typical driving cycles [13]. However, recent data suggests that typical driving cycles produce relatively low emissions with most emissions coming from off-cycle driving, cold-starts, and evaporative emissions. Furthermore, some portions of the off-cycle driving such as climbing steep grades are apt to be correlated with major meteorological features such as downslope winds. These linkages are important, but they are not treated systematically in the current modeling systems [14].

## 7. Conclusion

By applying forefront technologies and methods, the represented integrated transportation model can simulate

the dynamic details that contribute to the complexity inherent in today's and tomorrow's transportation issues. The integrated results from the detailed simulations can support transportation planners, engineers and others who must address environmental pollution, energy consumption, traffic congestion, land use planning, traffic safety, intelligent vehicle efficacies and the transportation infrastructure effect on the quality of life, productivity and economy [15 and 16].

## Acknowledgement

This paper presents results of work supported by the Slovak Scientific Grant Agency of the Slovak Republic under the project No. VEGA 1/0077/15.

## References

- [1] DROZDZIEL, P., KRZYWONOS, L.: The Estimation of the Reliability of the First Daily Diesel Engine Start-up during its Operation in the Vehicle. *Eksplatacja i Niezawodność - Maintenance and Reliability*, vol. 41, No. 1, 2009, 4-10.
- [2] GLOWACZ, A.: Diagnostics of DC and Induction Motors Based on the Analysis of Acoustic Signals. *Measurement Science Review*, vol. 14, No. 5, 257-262.
- [3] KOHAR, R., HRCEK, S., MEDVECKY, S.: Usage of Dynamic Analysis to Determine Force Interactions between Components of Rolling Bearings. *Communications - Scientific Letters of the University of Zilina*, vol. 14, No. 3, 2012, pp. 62-67.
- [4] <http://www.gisagents.org/2012/05/synthetic-population-data-for-us.html>
- [5] CABAN, J., DROZDZIEL, P., BARTA, D., LISCAK, S.: Vehicle Tire Pressure Monitoring Systems. *Diagnostyka*, vol. 15, No. 3, 2014, ISSN 1641-6414.
- [6] <http://ops.fhwa.dot.gov/publications/fhwahop10005/cs4.htm>
- [7] KOHAR, R., HRCEK, S.: Dynamic Analysis of a Rolling Bearing Cage with Respect to the Elastic Properties of the Cage for the Axial and Radial Load Cases. *Communications - Scientific Letters of the University of Zilina*, vol. 16, No. 3A, 2014, 74-81.
- [8] <http://ops.fhwa.dot.gov/publications/fhwahop13015/sec9.htm>
- [9] CABAN J., MARCZUK A., SARKAN B., VRABEL J.: Studies on Operational Wear of Glycol-based Brake Fluid. *Przemysł Chemiczny*, vol. 94, No. 10, 2015, 1802-1806.
- [10] <http://www.ecorys.nl/english/news/ecorys-develops-intermodal-route-planner-east-west-corridor>
- [11] BUKOVA, B., BRUMERCIKOVA, E., KONDEK, P., SOJCAK, D.: The Impact of International Entrepreneurship on the Development of Transport. *Communications - Scientific Letters of the University of Zilina*, vol. 18, No. 2, 2016, 139-142.
- [12] <http://ops.fhwa.dot.gov/publications/fhwahop10005/cs4.htm>
- [13] HRCEK, S., KOHAR, R., MEDVECKY, S.: Determination on the Maximum Roller Bearing Load with Regards to Durability thereof using FEM Analysis. *Communications - Scientific Letters of the University of Zilina*, vol. 14, No. 3, 2012, 55-61.
- [14] KOMSTA, H., BRUMERCIKOVA, E., BUKOVA, B.: Applications of NFC Technology in Passenger Rail Transport. *Transport Problems*, vol. 11, No. 3, 2016, 43-53.
- [15] BRUMERCIKOVA, E., BUKOVA, B., KRZYWONOS, L.: NFC Technology in Public Transport. *Communications - Scientific Letters of the University of Zilina*, vol. 18, No. 2, 2016, 20-25.
- [16] BUKOVA, B., BRUMERCIKOVA, E., KOLAROVA, P.: A Study of a Logistics Transport Chain in the Transport of Selected Commodity from Eastern Europe to China. *Nase more*, vol. 62, No. 4, 2015, 256-263.

Michal Lukac – Frantisek Brumercik – Leszek Krzywonos – Zbigniew Krzysiak\*

## TRANSMISSION SYSTEM POWER FLOW MODEL

Physical modelling of transportation system is helpful for finding information about the power flow in particular transmission elements. The vehicle power train model can be built from predefined blocks. The blocks are based on mathematical equations, which define every power train element. The procedure of the particular transmission element – a two-stage epicyclic gearbox model creation and calculation is described in the presented article.

**Keywords:** Gear system, power flow, model, simulation.

### 1. Introduction

The mathematical model of a gear system presented in this article is based on the principle of physical modelling of individual blocks representing elements of modelled transmission structure [1].

If the base data of the gearbox are known, the model of the gearbox inner structure can be built. The most important parameters for the calculation of epicyclic gear trains are fundamental ratios of the gearbox stages  $u_{v1}$  and  $u_{v2}$  and input performance parameters. The fundamental gear ratios define the internal structure of the gearbox. They are determined by the number of gear teeth in each stage of the gearbox. The performance parameters, after conversion from relative magnitudes obtained by simulation, determine the load on each element of the gearbox [2 and 3].

### 2. Gear train description

The calculated gear train (Fig. 1) is formed by two simply planetary gear stages, which are linked in series. The 1-st stage sun gear  $p_1$  is connected to the input shaft  $A$  and the 2-nd stage carrier  $r_2$  is connected to the output shaft  $X$ . The 1-stage carrier  $r_1$  is connected to the 2-nd stage sun gear  $p_2$ . Ring gears  $q_1$  and  $q_2$  in both gear stages are fixed to the gearbox case.

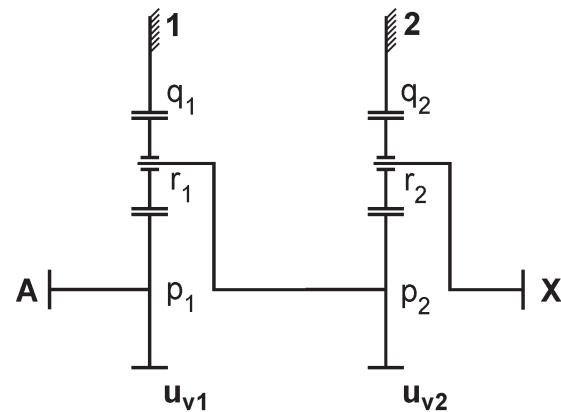

Fig. 1 Scheme of the solved two-stage epicyclic gear train  
(Source: authors)

### 3. Gear stage kinematics

The basic elements of the model are blocks of one-stage planetary gearbox defined by Mathworks Simcape Driveline software. The basic equation, which characterises the epicyclic gear train with 3 basic elements (sun gear  $p$ , ring gear  $q$  and carrier  $r$  - Fig. 2) and 2 degrees of freedom (DOF), is so called Willis formula [4]:

$$\omega_p - \omega_q u_v = \omega_r (1 - u_v), \tag{1}$$

where:  $\omega_p$  speed of the central wheel  $p$  (sun gear),

\* <sup>1</sup>Michal Lukac, <sup>1</sup>Frantisek Brumercik, <sup>2</sup>Leszek Krzywonos, <sup>3</sup>Zbigniew Krzysiak

<sup>1</sup>Mechanical Engineering Faculty, University of Zilina, Slovakia

<sup>2</sup>Lublin University of Technology, Faculty of Mechanical Engineering, Poland

<sup>3</sup>University of Life Science in Lublin, Faculty of Production Engineering, Poland

E-mail: brumercikf@fstroj.uniza.sk

- $\omega_l$  speed of the central wheel  $q$  (ring gear),
- $\omega_r$  speed of the carrier  $r$ ,
- $uv$  fundamental epicyclic gear ratio.

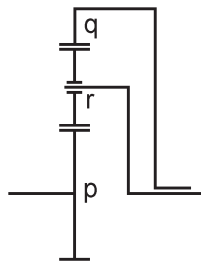

Fig. 2 Single epicyclic gear train with internal geared ring gear:  $p$  - sun gear,  $r$  - carrier,  $q$  - ring gear (Source: authors)

The fundamental epicyclic gear ratio is defined by the stopped carrier  $r$  as

$$u_v = \pm \frac{z_q}{z_p} = \frac{\omega_p}{\omega_q} \mid \omega_r = 0, \tag{2}$$

- where:  $z_q$  tooth number of the central wheel  $q$ ,
- $z_p$  tooth number of the central wheel  $p$ .

The sense of the gear ratio is negative, if the central wheel  $q$  has internal gearing, which is the case of both of the two-linked simple epicyclic gear trains solved in this task.

#### 4. Model environment and blocks

Matlab/SimScape is the computing environment equipped with blocks not only for mechanical, but also for the electrical, electromagnetic, hydraulic and pneumatic, fluid, and thermal models. It includes blocks, which are generally used by solving of any type of the upper described models and can be taken as a common base of blocks that are also useful with the connection with Driveline blocks, which describe common elements often used by the drivetrain modelling [5].

Following the principles of physical model building, it is necessary to connect block ports with input and output shafts of the gearbox, to connect the ports defining the inner structure of the gearbox and to fix the necessary element of the gearbox to obtain the DOF number equal to 1. The blocks, which are required for building a mathematical model for the power flow analysis of the calculated gear train, are described below.

#### 4.1 Planetary gear block

Figure 3 shows the mask of the planetary gear block in Matlab/SimScape Driveline software.

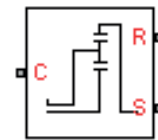

Fig. 3 Planetary gear block (Source: [5])

The planetary gear block has three connection ports:

- C - Carrier,
- S - Sun gear,
- R - Ring gear.

This block allows to define the fundamental gear ratio of the planetary gear-stage, e.g. by the number of gear teeth of the sun gear  $p$  and ring gear  $q$  put to the block parameters interface. Torque and angular velocity can be calculated by this block either with or without losses in gear mesh with the possibility to take into account the impact of the temperature and also the viscous losses from bearing of the sun and planet gears.

#### 4.2 Rotational reference block

The calculated gearbox is formed by two simple planetary gear stages, which are linked in series. Ring gears in both gear stages are fixed to the gearbox case. Modelling of this structural condition requires the usage of the general Matlab/Simscape block library.

This task requires the mechanical rotational reference block (Fig. 4). This block ensures the zero speed of connected ports during the calculation.



Fig. 4 Mechanical rotational reference block (Source: [5])

#### 4.3 Ideal torque source block

The calculation of speeds and torques of planetary mechanism elements formed by two stages requires to enter the initial values at the start of the simulation. Presented mathematical model has the input initial condition defined

by the relative input torque  $M_A = 1$ , which is applied on the gearbox input shaft A by the ideal torque source block (Fig. 5).



Fig. 5 Ideal torque source block (Source: [5])

The ideal torque source block has 3 ports:

- R - Mechanical rotational conserving port.
- C - Mechanical rotational conserving port associated with the source reference point (case).
- S - Physical signal input port, through which the control signal that drives the source is applied.

The block positive direction is from port C to port R. This means that the torque is positive if it acts in the direction from C to R. The power generated by the source is negative if the source delivers energy to port R.

#### 4.4 Ideal angular velocity source block

Presented mathematical model has the output initial condition defined by the relative output speed  $w_A = 1$ , which is applied on the gearbox output shaft X by the ideal angular velocity source block (Fig. 6).



Fig. 6 Ideal angular velocity source block (Source: [5])

This block has 3 connectors:

- R - Mechanical rotational conserving port,
- C - Mechanical rotational conserving port associated with the source reference point (case),
- S - Physical signal input port, through which the control signal that drives the source is applied.

Positive value of torque is defined by its action from connector R to the connector C. Relative angular velocity is defined by this block as

$$\omega = \omega_R - \omega_C \tag{3}$$

In the built-up model, the input relative angular velocity is defined as  $w_A = 1$ . If the gear ratio is known, the value of the relative angular output velocity is calculated as

$$\omega_X = \frac{\omega_A}{i_{AX}} = \frac{1}{i_{AX}} \tag{4}$$

The angular velocity and torque of individual mechanism model elements are detected with sensor blocks.

#### 4.4 Ideal torque sensor block

The Ideal Torque Sensor block represents a device that converts a variable passing through the sensor into a control signal proportional to the torque. The sensor is ideal because it does not account for inertia, friction, delays, energy consumption, and so on. The Ideal torque sensor block mask is shown in Fig. 7.

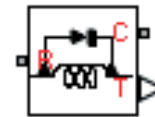

Fig. 7 The block- Ideal Torque Sensor (Source: [5])

This block has 3 connectors:

- R - Mechanical rotational conserving port associated with the sensor positive probe.
- C - Mechanical rotational conserving port associated with the sensor negative (reference) probe.
- T - Physical signal output port for torque.

#### 4.5 Ideal rotation motion sensor block

The Ideal Rotational Motion Sensor block represents an ideal mechanical rotational motion sensor, that is a device converting an across variable measured between two mechanical rotational nodes into a control signal proportional to angular velocity or angle. The sensor is ideal since it does not account for inertia, friction, delays, energy consumption, and so on.

The Ideal torque sensor block mask is shown in Fig. 8.

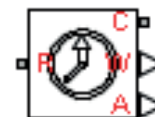

Fig. 8 The block Ideal Rotational Motion Sensor (Source: [5])

This block has 4 connectors:

- R - Mechanical rotational conserving port associated with the sensor positive probe,
- C - Mechanical rotational conserving port associated with the sensor negative (reference) probe,

- W - Physical signal output port for angular velocity,
- A - Physical signal output port for angular displacement.

5. Model calculation

After finishing the system model, there is need to define the block solver configuration, which performs the calculation [6 and 7]. It is also necessary to define the parameters of the numerical calculation method used for the model, which are suitable for the solution of a particular calculation problem.

The method used for the calculation of the presented gear train was the Runge-Kutta method (ode4 solver) with the fixed time step of 0.001 s.

For the solution of the presented gear train was made a complex model consisting of two blocks of simple planetary

gear (series connected) with the ideal torque source at the input and the ideal angular velocity source at the output. The block connectors are connected with lines representing rigid immaterial shafts, which generates the possibility to do also the static analysis of relative torques, angular velocities and performances of individual elements of the mechanism [8]. Performance parameters of the power flow are monitored with custom developed power sensors. The results are interpreted in the form of numerical values of the various parameters displayed on scopes connected to every tested element of the gearbox [9].

The complex gearbox model without calculating mesh losses in gears with the relative torques, angular velocities and performances parameters is shown in Fig. 9.

The complex gearbox model with calculating mesh losses in gears with the relative torques, angular velocities and

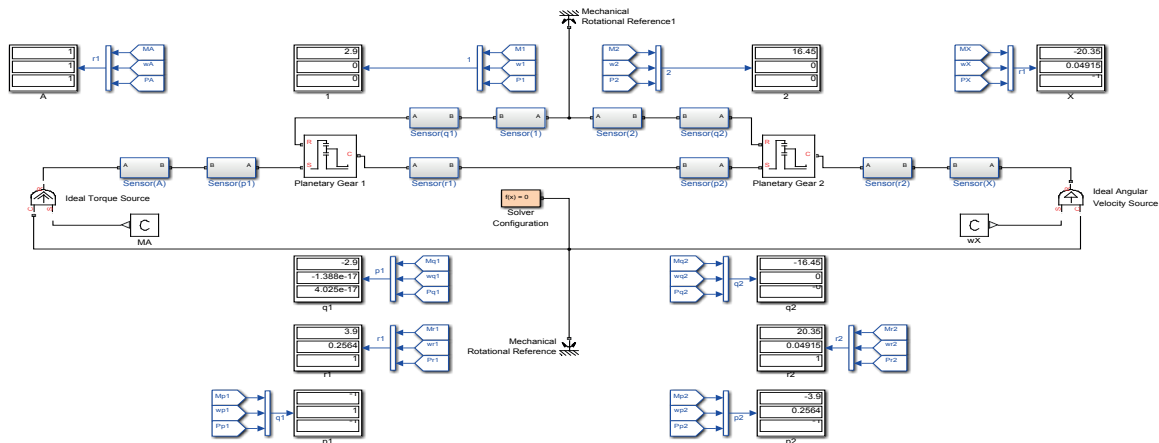

Fig. 9 Gearbox model - calculation without gear mesh losses (Source: authors)

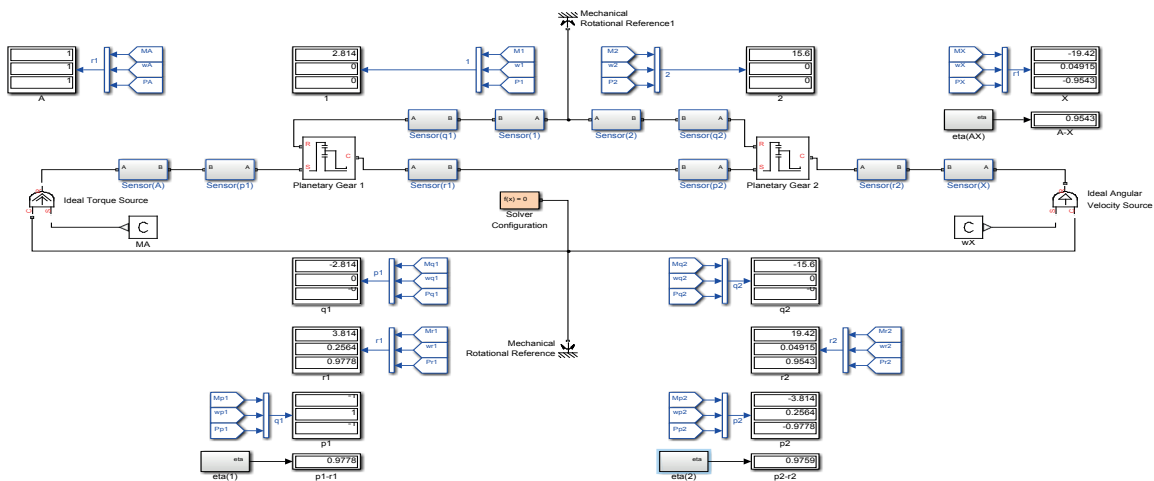

Fig. 10 Gearbox model - calculation with gear mesh losses (Source: authors)

performances parameters is shown in Fig. 10. The effectiveness of the external gear mesh was defined as  $\eta_e = 0.98$  and the effectiveness of the internal gear mesh as  $\eta_i = 0.99$  [10].

## 6. Conclusion

The article presents simulation results of an unconventional vehicle transmission, which can be used in commercial vehicles and mobile working machines. The kinematic structure and the dynamic behaviour of the system are extracted into the mathematical model [11]. Thus, the simulation of number of

load cases can be done and the control system can be tested without the need of number of prototypes to be built. The model provides also the possibility of the powertrain efficiency calculation. This allows to shorten the development time and to cut the costs in the area of R & D process significantly [12].

## Acknowledgement

This paper presents results of work supported by the Slovak Scientific Grant Agency of the Slovak Republic under the project No. VEGA 1/0077/15.

## References

- [1] DROZDZIEL, P., KRZYWONOS, L.: The Estimation of the Reliability of the First Daily Diesel Engine Start-up During its Operation in the Vehicle. *Eksploatacja i Niezawodność - Maintenance and Reliability*, 1(41), 2009, 4-10.
- [2] GLOWACZ, A.: Diagnostics of DC and Induction Motors Based on the Analysis of Acoustic Signals. *Measurement Science Review*, vol. 14, No. 5, 2014, 257-262.
- [3] KOHAR, R., HRCEK, S.: Dynamic Analysis of a Rolling Bearing Cage with Respect to the Elastic Properties of the Cage for the Axial and Radial Load Cases. *Communications - Scientific Letters of the University of Zilina*, vol. 16, No. 3A, 2014, 74-81.
- [4] HRCEK, S., KOHAR, R., MEDVECKY, S.: Determination on the Maximum Roller Bearing Load with Regards to Durability thereof using FEM Analysis. *Communications - Scientific Letters of the University of Zilina*, vol. 14, No. 3, 2012, 55-61.
- [5] DROZDZIEL, P., KOMSTA, H., KRZYWONOS, L.: Repair Costs and the Intensity of Vehicle Use. *Transport Problems*, vol. 8, No. 3, 2013, 131-138.
- [6] KOHAR, R., HRCEK, S., MEDVECKY, S.: Usage of Dynamic Analysis to Determine Force Interactions between Components of Rolling Bearings. *Communications - Scientific Letters of the University of Zilina*, vol. 14, No. 3, 2012, 62-67.
- [7] KOMSTA, H., BRUMERCIKOVA, E., BUKOVA, B.: Applications of NFC Technology in Passenger Rail Transport. *Transport Problems*, vol. 11, No. 3, 2016, 43-53.
- [8] CABAN, J., DROZDZIEL, P., BARTA, D., LISCAK, S.: Vehicle Tire Pressure Monitoring Systems, *Diagnostyka*, vol. 15, No. 3, 2014, ISSN 1641-6414.
- [9] Matlab reference, 1994-2016 The MathWorks, Inc.
- [10] CABAN J., MARCZUK A., SARKAN B., VRABEL J.: Studies on Operational Wear of Glycol-Based Brake Fluid. *Przemysł Chemiczny*, vol. 94, No. 10, 2015, 1802-1806.
- [11] BRUMERCIKOVA, E., BUKOVA, B., KRZYWONOS, L.: NFC Technology in Public Transport. *Communications - Scientific Letters of the University of Zilina*, vol. 18, No. 2, 2016, 20-25.
- [12] BUKOVA, B., BRUMERCIKOVA, E., KONDEK, P., SOJCAK, D.: The Impact of International Intrepreneurship on the Development of Transport. *Communications - Scientific Letters of the University of Zilina*, vol. 18, No. 2, 2016, 139-142.

Eva Brumerčiková - Bibiana Buková - Pavol Kondek - Paweł Drozdziel\*

## APPLICATION OF NFC TECHNOLOGY IN RAILWAY PASSENGER TRANSPORT BY INTRODUCING NEW PRODUCTS

*Near Field Communication (NFC) is a new trend in the world of information technology, which has a profound impact on all spheres of life. This technology is currently being applied in public transport services, which is confirmed by a number of passenger handling methods that use NFC throughout Europe. NFC technology offers convenience and mobility to users of public passenger transport. With NFC carriers may expand their portfolio of NFC supported services. This paper presents possible application of the NFC technology in railway passenger transport by introducing new products, and the possibility to expand the business portfolio of railway operators.*

**Keywords:** NFC technology, railway passenger transport.

### 1. Introduction

This article is focused on the design of implementation of NFC technology in railway passenger transport in Slovakia in the form of new products called "National Railway Card" and "Travel Easy". The implementation of NFC in railway passenger transport will bring benefits to the state, carriers as well as passengers. These benefits will include:

- faster passenger handling,
- less time waiting in line for travel documents,
- increased number of potential passengers,
- expanded service portfolio of carriers,
- better data summarization,
- contribution in the field of environmental policy of carriers [1 and 2].

### 2. "National Railway Card"

The basis of the "National Railway Card" is a contactless chip card (CCHC). Therefore, every passenger would have to possess a CCHC. The passenger could choose one of two CCHCs - a basic card or a personal card.

The basic card would be designed for "casual" passengers who do not use railway passenger transport on a regular basis. CCHC would cost 2 € and would be valid for five years. The

card would use the basic fare of carriers without any discount and would be transferrable to another user/passenger [3].

The personal CCHC would be designed for pupils/students and working people, who use the railway passenger transport to get to work, for pensioners, disabled people and other groups of people. CCHC would be issued upon filling in personal data and attaching a photo of the person concerned. Passengers entitled to a discount would have to submit a form proving their entitlement to a discount.

#### Usage

CCHC could be used in the system "National Railway Card" with all carriers operating railway passenger transport in Slovakia. CCHC could be used in two ways - on the basis of a pre-purchased travel document or by the method "Pay as You Travel."

Both methods would operate based on a subscription model, i.e. the passenger would have to store the travel document (TD) or deposit cash on his/her CCHC. The passenger could travel with a pre-purchased travel document stored on his/her CCHC with all carriers. The passenger could purchase the travel document in a cash desk, a stationary vending machine or over the Internet. The passenger would have to check-in at the beginning and check-out at the end of his/her journey. Based on these actions, the clearing operator

\* <sup>1</sup>Eva Brumerčiková, <sup>1</sup>Bibiana Buková, <sup>1</sup>Pavol Kondek, <sup>2</sup>Paweł Drozdziel

<sup>1</sup>Department of Railway Transport, Faculty of Operation and Economics of Transport and Communications, University of Žilina, Slovakia

<sup>2</sup>Politechnika Lubelska, Lublin, Poland

E-mail: bibiana.bukova@fpedas.uniza.sk

would be able to redistribute the income among different carriers [4]. In case of commercial train carriers, such as RegioJet, Arriva and LEO Express, the clearing operator would automatically assign payments to the carriers based on the pre-purchased travel document that would be issued with a reservation of a specific seat in a particular train. Figure 1 shows a flowchart of the method of transport based on a pre-purchased travel document.

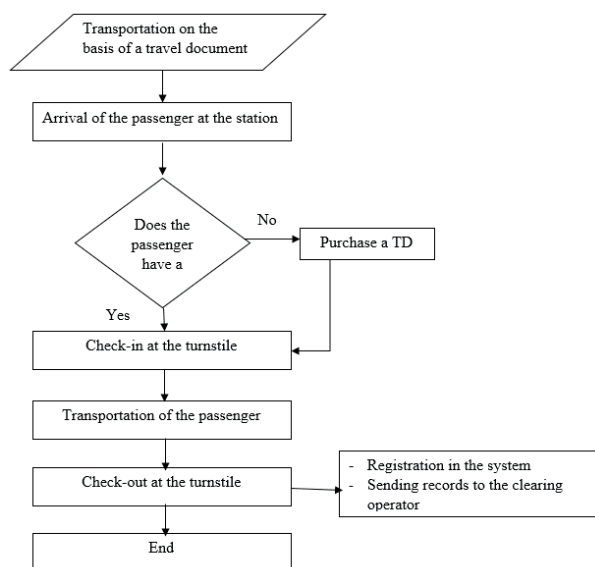

Fig. 1 Flowchart - TD

Figure 2 shows a flowchart of the method of transport "Pay as You Travel". This transportation system could be used in trains of Zeleznicna spolocnost Slovensko and RegioJet on the track Komarno - Bratislava. The system would operate in a way that the passenger would deposit enough cash on his/her CCHC and the price of transport would be automatically calculated at the end of the journey based on check-in/check-out and would be then subtracted from his/her CCHC, all just in a few seconds.

The fare would be determined based on the type of CCHC, either as a basic fare based on a basic card or as a reduced fare based on a personal card. It would be possible for the carriers to offer various loyalty programs for a personal CCHC, since this technology makes it possible [5].

Responsible for income redistribution would be a newly created entity - the clearing operator. Figure 3 shows the scheme of redistribution of income from travel documents. First, the passenger would purchase a travel document that would be stored on his/her CCHC or he/she would deposit some cash on his/her CCHC.

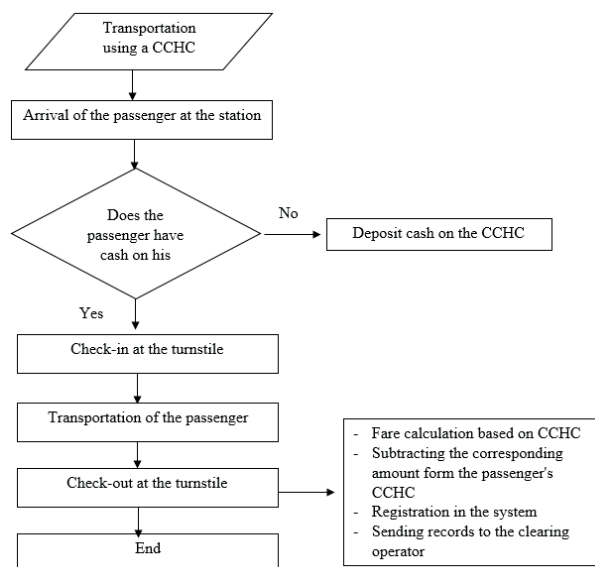

Fig. 2 Flowchart "Pay as You Travel"

The fare would be sent either to the bank, in case the passenger has purchased the travel document by credit card, or to sellers of travel documents (cash desk, stationary vending machine). At the end of the whole process all the funds would be sent to the clearing operator. Part of the funds from the income would go back to the sellers of travel documents or to the bank to cover their costs. The main part of the income would be redistributed by the clearing operator to the carriers. The income would be redistributed in a contractually agreed way based on the share of services of different carries used.

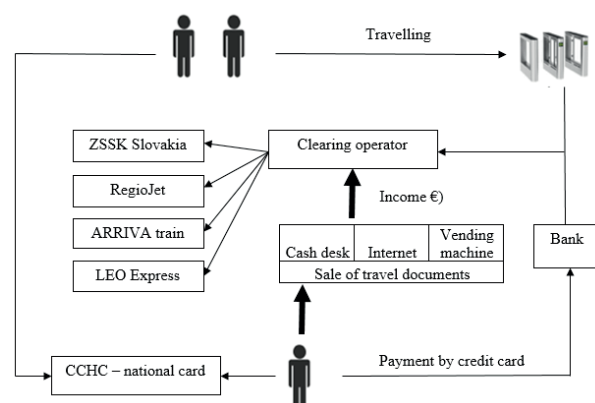

Fig. 3 Income redistribution scheme

Passengers travelling by rail would be recorded on the basis of check-in/check-out from the system. Based on these records, the clearing operator would be able to calculate the respective share of each carrier [6].

CCHCs would also replace various carriers' loyalty cards and passports, based on which the passenger is entitled to

a discount. All relevant information would be filled in by the passenger during CCHC registration and would be stored on the card, based on which the system would always determine the correct tariff for the individual passenger.

### 3. Mobile phone application - product "TRAVEL EASY"

NFC technology can be used in the form of a mobile phone application. The product "Travel Easy" is targeted at travellers who actively use their mobile phone and would prefer to purchase travel documents with a mobile app. The product "Travel Easy" could be designed as an additional service to the existing passenger handling service. In this case, the carrier would have to install NFC tags - contact points at railway stations or in the transport vehicles. An NFC tag, i.e. the contact point would be composed of an NFC chip and a QR code for wider public use. At each of these points there would be a simple manual in case of doubt with the use of the system by passengers.

Passenger using this technology would have to meet the following conditions:

- own a mobile phone,
- own an NFC SIM card,
- have a registered account on the Internet,
- download the "cestuj jednoducho" application,
- Internet access.

Passenger would be provided with NFC SIM cards by their mobile operator (Telefónica O2, Orange, Slovak Telekom). Since there already is cooperation between mobile operators and railway carries, cooperation would be ensured.

#### Usage

In order for a passenger to start using the system, he/she would have to register through the website. During the registration he/she would fill in all personal data and his/her phone number. If he/she was the owner of a loyalty card (e.g. KLASIK RAILPLUS) or a card based on which he/she would be entitled to a discount (e.g. ISIC), he/she would assign it to his/her account. Then he/she would procure an NFC SIM card from his/her mobile operator and download the application.

There would be the option to check-in/check-out through a QR code in the application. This would be for the case that there would be any problem with NFC, as well as for a broader range of travellers who could use this application even if they did not own a mobile phone with NFC.

Control during the journey could be done in two ways:

- upon check-in a TD would be sent to the passenger's NFC on his/her SIM card and during control the passenger would open the application and put his mobile phone to

the scanning device - the mobile phone would function as a CCHC with a stored TD, or

- upon check-in the passenger's TD would be sent to the application in form of a QR code, which he/she would show in case of control.

The flowchart in Fig. 4 shows the whole process of transport and the way of paying for the TD, which could be done in two ways.

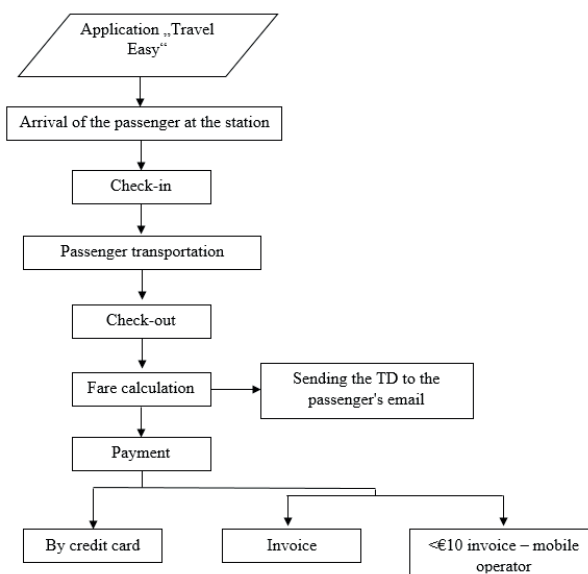

Fig. 4 Flowchart of the application "TRAVEL EASY"

The travel document could be paid in two ways:

- by credit card immediately after the journey - the credit card would be connected with the passenger's account and after system data synchronization the amount would be automatically subtracted from the traveller's account,
- by invoice: every month the passenger would receive an invoice with the sum of all TDs in that month. If the amount was less than € 10, it would be automatically added to the invoice issued by the mobile operator; if the amount was higher, a separate invoice would be mailed to the passenger's address provided during registration.

### 4. Conclusion

The NFC technology is an essential component of both products proposed. However, the products differ in the equipment used. The first product uses a CCHC card, the second uses a mobile phone. The main difference between these products is that the first product is of a bigger size and the impact on the society would be very large, since almost each passenger would have to get a CCHC. The second

product, i.e. the system “Travel Easy” is designed as an additional form of selling travel documents.

The purpose of both of these products is to simplify and speed up the handling of passengers. These products have a great perspective for the future through the increasingly expanding market with NFC technology. The product “National Railway Card” could be later extended by adding other kinds of public passenger transport to the national integrated system of public passenger transport in the Slovak Republic.

#### Acknowledgment

The paper is supported by the VEGA Agency by the Project 1/0095/16 “Assessment of the quality of connections on the transport network as a tool to enhance the competitiveness of public passenger transport system”, that is solved at Faculty of Operations and Economics of Transport and Communication, University of Zilina.

#### References

- [1] KOMSTA, H., BRUMERCIKOVA, E., BUKOVA, B.: Application of NFC Technology in Passenger Rail Transport. *Transport Problems - Scientific J.*, No. 3, 2016, 43-53. ISSN 1896-0596.
- [2] KAMPF, R., LIZBETIN, J., LIZBETINOVA, L.: Requirements of Transport System User. *Communications - Scientific Letters of the University of Zilina*. No. 4. 2012, 106-108. ISSN 1335-4205.
- [3] BRUMERCIKOVA, E., BUKOVA, B., KRZYWONOS, L.: NFC Technology in Public Transport. *Communications - Scientific Letters of the University of Zilina*, No. 2, 2016, 20-25. ISSN 1335-4205.
- [4] BRUMERCIK, F., LUKAC, M., CABAN, J.: Unconventional Powertrain Simulation. *Communications - Scientific Letters of the University of Zilina*, No. 2, 2016, 30-33. ISSN 1335-4205.
- [5] BRUMERCIK, F., DANKO, R.: Transport Application of Hybrid Simulation. *Communications - Scientific Letters of the University of Zilina*, No. 2, 2014, 20-24. ISSN 1335-4205.
- [6] HANZL, J., BARTUSKA, L., ROZHANSKAYA, E., PRUSA, P.: Application of Floyd’s Algorithm on Transport Network of South Bohemian Region. *Communications - Scientific Letters of the University of Zilina*, No. 2, 2016, 68-71. ISSN 1335-4205.

Anna Urbanek\*

## BIG DATA - A CHALLENGE FOR URBAN TRANSPORT MANAGERS

*Big data is a term used to describe large, variable and very diverse data sets, which are very difficult to process and analyse, but on the other hand which are extremely valuable from the point of view of gaining knowledge, for example, on consumer behaviour or real-time changes in a specific market. Automated fare technologies in public urban transport are implemented ever more widely in many cities worldwide. Because of these technologies the public transport organisers have access to large data sets, which create new possibilities in the decision-making process. The aim of the paper is to discuss the role of big data in the decision-making process in urban public transport and also the main barriers to big data use in the urban mobility management.*

**Keywords:** Big data, urban transport, smart card, electronic ticketing, fare collection, public transport, transportation demand.

### 1. Introduction

Information and Communication Technologies (ICT) and geolocation technologies are more and more universally used in every field of life and increasingly strongly affect all its aspects. Investments in modern electronic fare collection systems for the urban public transport services are ever-more popular in cities worldwide. Such systems gradually replace traditional fare collection systems based on paper tickets, the use of which is related to numerous limitations linked primarily with the possibilities of differentiating fares, the need to ensure a distribution network of appropriate reach, as well as with possibilities of acquiring knowledge about the demand for services.

The first electronic tickets originated with the development of magnetic strip card technology in the 60-ies of the 20th century in the United Kingdom. That technology was relatively simple and cheap. The main drawback of cards and tickets with a magnetic strip was the fact that they required a physical swipe and did not ensure a sufficient level of safety, because it was easy to read and reprogram them. Moreover, this technology did not enable the collection of data on the demand for urban public transport services [1]. Modern electronic payment systems for urban public transport based on contactless electronic cards and mobile telephony are relatively new technologies. Such technologies have been implemented on a wide scale only for around twenty years.

Hence the potential to use all data sets generated by these systems in the process of urban public transport management is the topic, which has not been studied enough in the literature of the subject.

### 2. Big data definition

Big data is a term, which – in the meaning used now – appeared in the scientific literature only at the end of 90-ies of the 20<sup>th</sup> century [2]. One of most comprehensive definitions of the big data term was created by Einav and Levin in 2013. In accordance with this definition, big data are big datasets available on a large, massive scale (millions or billions of observations), available in real time or close to it, having many variables, very diversified in terms of kind and type, and also much less structured than the datasets used so far [3]. In 2001 the Gartner company (formerly META Group) created a big data definition in so-called 3V model, which emphasises three main features of so big datasets [4]:

- high-volume (large amount of data),
- high-velocity (high speed/variability of received and sent data),
- and high-variety (high variety of data and sources of their origin).

In addition, in their definition the Gartner analysts indicate that these are the data that require new, innovative

\* Anna Urbanek

Department of Transport, Faculty of Economics, University of Economics in Katowice, Katowice, Poland  
E-mail: anna.urbanek@ue.katowice.pl

forms of processing to support the decision making, to explore new phenomena, and also to optimise and automate processes [4].

One could say most generally that these are sets of information about the surrounding world, to which we have access due to the fact that it is generated by all the equipment featuring an indirect or direct capability to gather, process or exchange data through computer networks. This means in practice e.g. all cameras, sensors, mobile phones, smart phones, cars, objects which could be geolocated, payment cards, RFID readers etc. In the digitised world big data are generated without human interference, beyond intentions and frequently also beyond human awareness, creating a kind of Digital Universe. Big data is not information as such; to become information the data must be appropriately categorised and analysed, which turns out to be not an easy task. Figure 1 presents the forecast growth of data generated in individual years between 2009 and 2020 measured in exabytes (1 EB is approx.  $10^9$  GB). It is estimated that in 2020 the mankind will generate 40,000 EB, of which only 33% could be categorised, analysed and used as information significant from the interesting processes point of view [5].

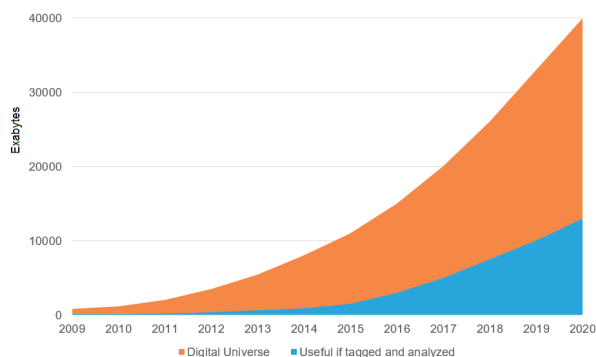

Fig. 1 Data growth between 2009 and 2020.

Source: Own study based on [5]

The big data processing and analysing is difficult, but very valuable. Already today many companies build their competitive advantage on the market exactly due to the data analysis. For example, cookies gathered in an internet browser are used for marketing purposes, to match the offer with individual consumer needs, and special computer software analyses behaviour of people visiting websites so as to optimise planning inventories of appropriate products included in the offer [6].

### 3. Big data sources in urban public transport

With increasingly popular implementation of electronic payment systems for public transport services in cities, the big data analysis and use plays an increasingly great role in the process of urban public transport management. E-ticket systems compared with distribution systems based on paper tickets create huge possibilities in the field of price differentiation as well as of collecting the data on the demand for transport services. Two types of electronic fare collection systems in urban public transport are now being implemented and developed throughout the world, i.e. contactless smart cards and mobile ticketing. Three main types of e-tickets may be distinguished in the mobile ticketing technology [7]:

- premium SMS based transactional payments - user pays fare with the next phone bill or pays for the travel from funds available on his/her pre-paid card,
- OCR (optical character recognition), when passenger/user receives a special code, for example a QR code that contains all needed information,
- NFC (Near Field Communication) technology, where the process is very similar to the OCR technology, but in the case of NFC the information is saved in the NFC memory of the phone.

OCR and NFC technologies become more and more popular, slowly replacing payments via SMS messages. This is related to a widespread use of smart phones and of special applications available for such devices. By means of them passengers have a possibility to buy the ticket of selected public transport organiser and to pay for it without cash by means of a payment card, which the user assigns to his/her individual account. So a smart phone can be not only a carrier of a season ticket, but also an e-money carrier, and may be used as a journey planner as well.

In the case of contactless smart cards technology passengers use a plastic card with an embedded chip, storing the most important information. Such cards need only to place them close to the reader at a distance of approx. 10cm, and they communicate via high-frequency waves like a Radio Frequency Identifier (RFID) [8]. Nowadays this is the most popular technology of electronic fare collection in the urban public transport. The first smart cards started to be used on a large scale in the 1980s. Today they are widely used in banking, health care, government and transportation. The microprocessors used now in contactless smart cards are produced based on EMV (the acronym for Europay, MasterCard and Visa) technology standards. It provides great possibilities in the field of information processing and transaction management, which is very important in the case of dynamic cost and travel time settlement in urban public transport [9]. The functionality of contactless smart cards is very broad:

- they can be e-money carriers and operate as payment cards,
- smart cards can be carriers not only of one, but also of many public transport organiser tickets [10],
- individual concession rights can be encoded on smart cards, even for several public transport organisers,
- smart cards can be anonymous or personalised, i.e. assigned to a specific user, each card has its unique number,
- smart cards can be carriers of single travel and season tickets as well as can operate in dynamic travel cost settlement systems, so-called pay as you go, that is requiring to register the entry to and the exit from the vehicle to calculate the payment for the really travelled distance, time period, number of stops etc. [9].

Substantial part of e-ticket systems operating now worldwide in large cities and metropolises is based on the contactless smart cards technology and on the registration of entering and leaving the vehicle, so-called Check-in/Check-out (it requires that passengers physically register the vehicle entering and leaving by placing a smart card or mobile phone in front of a reader. The system calculates then the due fare and charges it to the passenger account [7 and 11]. The e-tickets technology allows to identify and record all transactions made by passengers, i.e. the place and time of buying a specific ticket type, entering and leaving the vehicle etc. However, attention should be drawn to the fact that the data source in such systems comprises not only smart cards, but also urban transport vehicles equipped with GPS (Global

Positioning System) as well as on-board computers and other devices being an inseparable part of the ticket distribution and control system.

To illustrate the data sources and sizes of data sets obtained by a public transport organiser we can use the example of Silesian Public Services Card (SKUP) project, implemented in 2015 by the Municipal Transport Union of the Upper-Silesian Industrial District (KZK GOP), which is the largest in Poland and one of largest public transport organisers in Europe. Table 1 specifies the most important figures describing the KZK GOP and the SKUP project infrastructure.

The Union is made now of 29 municipalities of the central part of the Silesian Voivodship. The project is also participated by two municipalities (Tychy and Jaworzno), which are not members of the KZK GOP. The project is aimed at establishing a supra-local IT system, which will increase the scope and accessibility of services provided by public institutions via electronic channels and at the same time it will become a tool supporting the process of management in public administration. SKUP contactless smart card is an e-money carrier, which enables making payments not only for the public transport, but also for municipal administrative services, cultural and recreation-collective services, libraries and for parking. So the SKUP card is not only a carrier of season e-tickets in urban public transport, but also allows dynamic settlement of travel cost and time in pay as you go systems in various tariff systems [12].

Selected data related to the KZK GOP and the Silesian Public Services Card project

Table 1

|    |  |   |
|----|--|---|
| 1  | Population of KZK GOP municipalities   | 1,951,603   |
| 2  | Number of lines (bus and tram)   | 346   |
| 3  | Number of vehicles equipped with on-board computers and operating in the SKUP network                          | 1,350   |
| 4  | Number of mobile modules to collect fares/recharge cards (external sales network and municipal points)         | 1,210   |
| 5  | Number of parking meters operating in the SKUP network   | 223   |
| 6  | Number of ticket machines  | 154   |
| 7  | Number of passenger service points (KZK GOP and external points)   | 47  |
| 8  | Number of devices to check the passenger rights in vehicles (so-called 'ticket inspectors')                    | 320   |
| 9  | Number of SKUP cards issued (as of 31 August 2016)   | 171,761 (of which 160,359 personalised cards)                 |
| 10 | Number of SKUP cards issued (forecast as at 2017 end)  | 250,000   |
| 11 | Monthly number of registered cases of entering and leaving the vehicle in the system (data for August 2016)    | 4,746,292 (check-ins)<br>3,439,379 (check-outs)               |
| 12 | Average monthly number of registered cases of entering and leaving a vehicle in the system (forecast for 2017) | approx. 22,000,000 check-ins<br>approx. 18,000,000 check-outs |
| 13 | Average monthly number of sold single travel tickets (paper tickets) in 2015                                   | 4,320,975   |
| 14 | Average monthly number of sold season tickets (paper and electronic tickets for the SKUP card) in 2015         | 114,331   |
| 15 | Average monthly number of single travel tickets sold in 2015 via mobile phones and mobile applications         | 37,827  |
| 16 | Number of visits on the KZK GOP website (time tables) including via mobile devices in 2015                     | 25,795,862  |
| 17 | Number of time table changes in 2015   | 387   |

Source: Own study based on the KZK GOP figures

The SKUP project was implemented in October 2015, hence it is still not possible to refer to a full system operation. The first year of system operation is a transition period, during which passengers just learn the new rules of tickets purchase and validation and also the process of SKUP cards issuing continues. Hence the table presents the KZK GOP forecasts related to sizes of generated data, assuming a full operation of the system. As Table 1 shows the commissioning of electronic payment system for urban services, of which primarily for urban public transport, requires substantial investments in the IT infrastructure. The data generated by such system users and all its component devices are diversified and create huge sets that require categorisation and analysis.

#### 4. The big data role in the process of public transport management in cities

Automatic fare collection systems are implemented more and more frequently in cities worldwide; they are a source of big amount of data about movements, transactions made and transport behaviour of city residents. This is of particular importance especially in the context of growing population of the cities. The urbanisation progressing in recent years is one of most important processes of economic, spatial, political and social importance. More than a half of the global population (54%) lives now in cities and only 200 years ago the city population made only 3% of the total. In the European Union countries approx. 75% of population live in cities, and it is forecast to grow to around 84% by 2050 [13].

The increasing population of cities and at the same time the expectation of good living and travelling conditions in cities create a challenge for the urban transport, because transport is one of factors enabling the city development. A quantitative development of transport in cities is limited not only by the urban space, the transport network capacity, but also by possibilities to finance investments from public funds. Hence the role of information about the demand for transport services is so great, as it becomes the basis to make decisions in the field of pursuing a more effective use of the possessed resources.

The majority of demand study methods used now, starting from preference studies up to advanced traffic modelling systems, are based on data acquired from entities, occupancy measurements and questionnaire surveys (most often carried out by interviewers), acc. to the rules developed decades ago, when the ICT were not so widely used. Today the data originating from daily events registered by IT systems (generated by the users and acquired from the equipment) can replace many methods used so far and can be used for the needs to build traffic models. The development of a traffic model for a specific area requires first of all the knowledge

about the traffic size on individual routes in specified time periods, the knowledge of traffic sources and destinations, and also about the used means of transport. Electronic payment systems for public transport services provide numerous precise observations on the transport behaviour, which could be referred to time and specific place in the transport system and analysed dynamically in a selected period of time. Traffic models created for the needs to manage urban public transport may be used primarily for the analysis of the existing situation, which is applicable in operational short-term management of the transport offer, and for forecasts, i.e. for long-time planning.

The current management of the transport offer consists mainly in adapting the offer to current needs and expectations of residents. Traffic models allow to carry out simulations and assessments of changes introduced in the transport system and based on that to introduce current changes in the public transport offer. Most often such changes primarily consist in adjusting the vehicles running frequency, modifying the line routes or changing the capacity of vehicles servicing the transport lines. The number of carried out modifications depends on the size and nature of the area, in which the public transport is managed. For example, in the KZK GOP in Katowice approx. 400 modifications of time tables are made every year, consisting mainly of line route changes, changes resulting from including or excluding the service of new stops or changes of the time and frequency of vehicles. Precise knowledge about the number of passengers using urban public transport on a given route during a specific time of day is indispensable for a public transport organiser, because each additional journey of a vehicle on the line means additional costs for the municipality equal to EUR a few dozen or a few hundred thousand annually. None of occupancy calculation methods used so far can provide this knowledge [14].

An equally important application of traffic models consists in long-term, frequently in a perspective of a dozen or so years or several decades, forecasting of changes in the city transport system operation and related changes of transport behaviour, which result from changes in the land development, including implementation of new investments in the city, e.g. new plants, education facilities, commercial and service centres, housing estates and recreation places as well as of other facilities being the traffic sources and destinations [14].

The use of data related to the demand for services, whose sources are the modern ICT technologies implemented in urban public transport, provides benefits to public transport organisers and to passengers as well. The knowledge about passenger flows allows a more effective management of the transport offer (e.g. a better adaptation of vehicles in terms of capacity, optimisation of the number and frequency of journeys), which can result in cutting the expenditures on the operations. A better understanding of transport behaviour

allows primarily to adapt the transport offer to the passenger needs and to increase the public transport attractiveness. Precise knowledge of transactions carried out, that is the tickets type, number and time of purchase, allows a more flexible and innovative pricing policy [9]. Longer-term image improvement can result in increased demand for services and increased revenue from ticket sales. Moreover, increasing the competitiveness and attractiveness of public transport, in particular against individual means of transport, may also be the source of external benefits perceived by all residents of specific area or city. The reduction of travels carried out by the individual transport results first of all in the reduction of congestion and of adverse environmental impact (lower emission of pollutants and noise) and improvement to the quality of life in cities and urbanised areas.

Precise data on passenger flows and ticket revenues on individual lines may be used also to make more detailed mutual settlements between operators or municipalities, who organise together the public transport in a specific area. The scope of data used in such case depends then on the adopted model of financing. In the case of the SKUP project implemented by the KZK GOP, being a union of 29 municipalities, the introduction of rules of settlement with municipalities was one of the main assumptions made for the system. A new model of KZK GOP urban public transport financing assumes using the data from registration of entering and leaving vehicles for the needs to calculate the line profitability. To calculate the ticket revenue for a specific line it is necessary to link the information about ticket (season and single travel) prices with the total number of travelled kilometres during ticket validity periods broken down to lines and municipality areas [15].

## 5. Barriers to big data use in urban public transport

The use of big data generated by electronic payment systems in urban public transport is related primarily to concerns for personal data protection. This is an issue relatively broadly considered in research studies [16]. Each mobile phone, smart phone and each smart card has its unique number. In addition, each mobile phone, smart phone and personalised smart card is assigned to an individual user together with his/her detailed personal data, which are stored in personal databases of mobile network operators, card issuers etc. So the concerns for the privacy protection are common to all technologies, which link a device or card with a specific user and which allow to gather data on his/her behaviour (mobile telephony, bank systems, i.e. credit and payment cards or smart cards used in the health service, urban public transport etc.).

Modern e-payment systems in the public transport based on smart cards satisfy the strictest safety standards, determined

by bank systems. In very many cases these are just banks who are partners of such projects in cities, being responsible for issuing the cards and also for storing and processing the personal data of users. It should be also considered that the issue of personal data protection is regulated in the European legislation in a very restrictive way, in particular in the context of dynamic development of ICT tools, which enable the data gathering and processing on a scale unprecedented so far.

To carry out studies on the transport behaviour and on the demand, a public transport organises needs, apart from the data about mobility and passenger flows, also the knowledge about passengers' age structure and related rights to concessionary travels. In numerous models, in particular those in which the data from e-ticket systems are used for mutual settlements between operators or municipalities organising transport together, there is also a need to gain the knowledge of the municipality of residence [16]. Because of restrictive legislation in this field, the databases containing the personal data of system users are separate from databases used in the process of analysis. That means that in the process of studying the passengers' mobility a public transport organiser should not combine those databases and explicitly identify passengers. Exactly the same processes may be encountered in the bank sector or at mobile networks operators, who for the needs to carry out business and marketing research also analyse the user transactions.

It is also worth noticing that in the literature of the subject more and more attention is paid also to studies on mobility in cities using the geolocation data of residents' smart phones and mobile phones [17]. The generality degree of data acquired from sensors and satellite systems makes them now much less useful than from systems based on smart cards, and the use of more detailed information, e.g. from mobile telephony operators, is very problematic, mainly due to issues related to the personal data protection.

The barriers to the big data use in the process of public transport management should undoubtedly include the cost of an electronic fare collection system implementation. The big data collection most frequently means a systematic or stepwise expansion of IT in the entity. Most often this is an effect of substantial investments in the IT system and it is related to significant funds spent on the system maintenance. This is a costly and time-consuming investment, which requires:

- building an extensive, technologically advanced IT infrastructure (e.g. the issue of building or renting large data processing centres and the necessity to ensure their operation continuity),
- training people, acquiring extensive and specialised knowledge,
- numerous organisational changes.

For example, the total net cost of the SKUP project implementation and its maintenance during 5 years from

commissioning amounts to approx. PLN 190 million (i.e. around EUR 45 million). The process of project preparation and its implementation took approx. 7 years. It should be added that the project was co-financed from the European Regional Fund under Regional Operational Programme of Silesian Voivodship for the years of 2007 - 2013 [12]. Figure 2 presents the main groups of barriers to the big data use in the urban public transport.

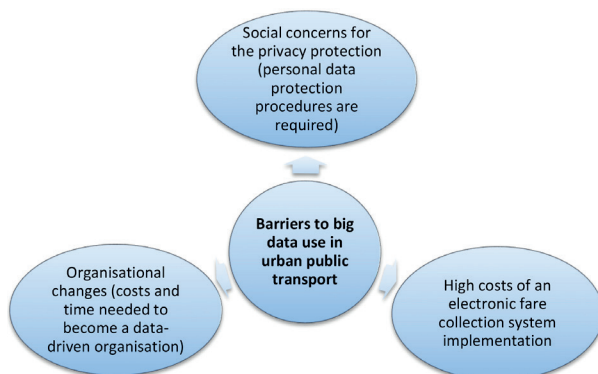

Fig. 2 Main barriers to big data use in urban public transport.

Source: Own study

Moreover, it is necessary to draw attention to the fact that the traffic models development, apart from buying specialised software for urban traffic modelling and forecasting, which is also a costly investment for a public transport organiser, requires structured information. Huge amounts of data received from the system require pre-categorisation and analysis, so that later they could feed not only traffic models, but be useful in the decision making. That requires the next IT tools, specialised knowledge, and also new analytical methods.

## 6. Conclusions

ICT technologies are increasingly widely used in urban public transport, primarily in electronic payment

systems, which are ever-more universally implemented in cities worldwide. Such systems generate huge and diversified datasets, providing numerous precise observations on the transport behaviour and passengers mobility. This data can be the source both of current information about the market, available almost in real time, and also can become the basis for long-term analyses and plans. None of hitherto known and used research methods can provide such knowledge. The progressing urbanisation and the striving for an increase in the effectiveness of provided services make that the role of using the information brought by big data in the process of mobility management in cities has been growing.

The possibility of collecting accurate data about the demand for services, which beyond any doubt is the greatest advantage of those systems, on the other hand is a significant element raising some social concerns. They refer first of all to maintaining the privacy of users and safety of personal data. Such concerns frequently result also in a very slow process of such systems acceptance in society [18].

The performed analysis shows that the role of data acquired from the ICT systems has been permanently growing in the process of collective public transport management. This determines a new direction of changes for this sector, in which the entities managing the urban public transport to a larger and larger extent will transform into so-called data-driven organisations. In the past the data acquisition was the main problem of mobility and transport behaviour analyses. Today the vastness and diversification of received data make that the problem consists in their categorisation and analysis, so as to make them useful in decision making. The analysis of the subject literature and of research performed in this field shows that the possibilities to use the data in the process of urban public transport management are only being studied. This is the area of utilising the scientific knowledge in the field of economy, transport engineering, and information science as well as of cooperation between the sector of science and the business and the transport policy entities on various levels.

## References

- [1] TURNER, P., SMITH, B.: *Integrated Electronic Ticketing - Field of Dreams?* Eighth World Congress on Intelligent Transport Systems, Sydney, October 2001
- [2] BRYSON, S., KENWRIGHT, D., Cox, M., Ellsworth, D., Haines, R.: Visually Exploring Gigabyte Data Sets in Real Time, *Communications of the ACM*, vol. 42, No. 8, 1999, 82-90, ACM New York
- [3] EINAV, L., LEVIN, J. D., 2013, The Data Revolution and Economic Analysis, *Working Paper Series*, No. 19035, National Bureau of Economic Research : Cambridge
- [4] LANEY, D.: *Application Delivery Strategies. 3D Management: Controlling Data Volume, Velocity, and Variety*, META Group, File: 949, 6 February 2001. Available at: <http://blogs.gartner.com/doug-laney/files/2012/01/ad949-3D-Data-Management-Controlling-Data-Volume-Velocity-and-Variety.pdf> [date of access: 2 August, 2016]

- [5] GANTZ, J., REINSEL, D.: *The Digital Universe in 2020: Big data, Bigger Digital Shadows, and Biggest Growth in the Far East*, 2012, IDC.
- [6] JESKE, M., GRUNER, M., WEISS, F.: *Big Data in Logistics. A DHL perspective on how to move beyond the hype*, DHL Customer Solutions & Innovations, 2013. Available at: [http://www.dhl.com/content/dam/downloads/g0/about\\_us/innovation/CSI\\_Studie\\_BIG\\_DATA.pdf](http://www.dhl.com/content/dam/downloads/g0/about_us/innovation/CSI_Studie_BIG_DATA.pdf) [date of access: 5 August, 2016]
- [7] Integrated urban e-ticketing for public transport and touristic sites. Science and Technology Options Assessment. European Parliamentary Research Service, Brussels (2014), Available at: [http://www.europarl.europa.eu/RegData/etudes/etudes/join/2014/513551/IPOL-JOIN\\_ET%282014%29513551\\_EN.pdf](http://www.europarl.europa.eu/RegData/etudes/etudes/join/2014/513551/IPOL-JOIN_ET%282014%29513551_EN.pdf) [date of access: 5 August, 2016]
- [8] PELLETIER, M.-P., TREPANIER, M., MORENCY, C.: Smart Card Data Use in Public Transit: A Literature Review. *Transportation Research Part C: Emerging Technologies*, vol. 19, No. 4, 2011, 557-568, Elsevier 2011
- [9] URBANEK, A.: Pricing Policy after the Implementation of Electronic Ticketing Technology in Public Urban Transport: An Exploratory Study in Poland, Mikulski, J. (ed.) TST 2015. CCIS, vol. 531, 322-332, Berlin Heidelberg, Springer 2015
- [10] URBANEK A., Electronic Ticket as a Key Element for Integration of Regional and Local Public Transport: Examples of European Solutions, *Logistyka*, No. 4, 2015, 1543-1552, Instytut Logistyki i Magazynowania
- [11] Integrated mobility with eTicketing. The intermodal and interoperable eTicketing platform for consistent, end-to-end mobility chains in cities. Siemens AG (2012), Available at: [http://w3.siemens.com/topics/global/en/events/hannover-messe/metropolitan-solutions/Documents/eTicketing\\_EN.pdf](http://w3.siemens.com/topics/global/en/events/hannover-messe/metropolitan-solutions/Documents/eTicketing_EN.pdf) [date of access: 10 August, 2016]
- [12] SKUP Website [www.kartaskup.pl](http://www.kartaskup.pl) [date of access: 10 August, 2016]
- [13] UNITED NATIONS, Department of Economic and Social Affairs, Population Division, 2014. World Urbanization Prospects: The 2014 Revision, Highlights (ST/ESA/SER.A/352)
- [14] DYDKOWSKI G., URBANEK A.: Directions and Benefits of Using Traffic Modelling Software in the Urban Public Transport, Mikulski, J. (ed.) TST 2013. CCIS, vol. 395, 23-31, Berlin Heidelberg : Springer 2013
- [15] URBANEK A.: Directions of Broadening the Range of Tariff Systems Functionalities in Urban Transport, *Archives of Transport System Telematics*, vol. 7, No. 4, November 2014, 50-54
- [16] DEMPSEY, S. P.: *Privacy Issues with the Use of Smart Cards*. Legal Research Digest, Transport Cooperative Research Program, 2008
- [17] DO, T.M.T., GATZIA-PEREZ, D.: Where and What: Using Smartphones to Predict Next Locations and Applications in Daily Life, *Pervasive and Mobile Computing*, vol. 12, 2014, 79-91
- [18] DEAKIN, E., KIM, S.: *Transportation Technologies: Implications for Planning*. University of California Transportation Center, Paper # 536, 2001.

Grzegorz Dydkowski - Anna Urbanek\*

## PRICES AS AN ELEMENT OF COMPARATIVE STUDIES ON PEOPLE'S TRAVELS IN CITIES

*Ticket prices are one of crucial factors of urban public transport services competitiveness. Ticket prices are expected not only to ensure appropriate revenue for the urban public transport organiser, by they are also an important instrument of cities' transport policy. The paper is aimed at comparison of urban public transport prices in the largest Polish cities taking into consideration diversified purchasing power as well as the economic potential of city residents and also the competitiveness against the individual car transport. The presented and applied method for comparisons is recommended in particular to compare centres featuring high diversification of the economic potential and of the purchasing power of the population.*

**Keywords:** Urban public transport, prices, fares, comparative analysis, cities, pricing policy.

### 1. Introduction

Comparative studies are significant in the price management process, including the urban public transport, first of all to compare substitute methods for people's travels, such as urban public transport, taxis, or individual car transport. The comparisons of qualitative features and other significant characteristics for travellers as well as of price or cost of specific travel allow to assess the attractiveness, competitiveness and substitutability of various travelling methods. This way one can assess e.g. the tendency to give up the urban public and to use the individual transport.

Although the issues of price setting provided some output in the urban transport economics [1 - 5], but the literature on the topic is short of price comparative studies, which would allow to assess the pricing policy in cities and directions of tariff systems development. So far this issue has been described in the broadest way in the book 'Urban Transport Prices In Europe' (2007), edited by R. Tomanek [6], in which prices and tariffs of urban public transport were studied and compared in 100 European cities.

This paper focuses primarily on price comparative studies, including in particular price comparisons between the largest cities in Poland and referring those prices to the purchasing power of city residents and also to the economic potential. Such comparisons allow to evaluate the price policy pursued in the urban public transport in Poland.

### 2. Comparative Studies on Urban Public Transport Prices

When analysing prices, including public transport service prices, it is not possible to limit oneself to the provision of nominal figures or their changes in a selected period of time. The nominal value, or supplemented only by this value change in time, explains not much without any reference. It becomes necessary to refer the price to the consumer goods and services price increase index, and from the service provider point of view – to indices presenting price rises of the basic productive factors. In the case of transport services, where the fuel and labour costs are important cost elements, the human factor has double importance. On the one hand the remunerations and related charges generate a substantial cost, on the other hand remunerations create the purchasing power and hence possibilities to buy specific goods on the market. So higher remunerations are a factor increasing the entity costs, but also increasing possibilities to buy specific goods and eliminating their price increase.

The comparison of prices in a time period, taking into account the change of money value in time, or comparisons of substitutes' price changes do not exhaust the work, which would allow to assess the price development – in this case prices of urban public transport services. It is also advisable to make comparisons in space, i.e. with other cities. The scope of comparison can be limited only to cities within the country,

\* Grzegorz Dydkowski, Anna Urbanek

Department of Transport, Faculty of Economics, University of Economics in Katowice, Katowice, Poland  
E-mail: grzegorz.dydkowski@ue.katowice.pl

Comparison of nominal prices of basic ticket types in studied cities in 2016

Table 1

| Area/Ticket type | Nominal price of single travel ticket in the urban zone (PLN) | Nominal price of single travel time ticket (30-40 minutes) (PLN) | Nominal price of a personal monthly ticket or 30-day ticket for the whole network (PLN) | Nominal price of a bearer monthly ticket or 30-day ticket for the whole network (PLN) |
|------------------|---|--|---|---|
| Poznan           | -   | 4.60   | 199.00  | -   |
| Szczecin         | -   | 3.00   | 162.00  | 170.00  |
| Bydgoszcz        | 3.00  | -  | 120.00  | 140.00  |
| Wroclaw          | 3.00  | 3.00   | 98.00   | 170.00  |
| Katowice         | 3.10  | 3.70   | 144.00  | 168.00  |
| Gdansk           | 3.20  | -  | 104.00  | 117.00  |
| Krakow           | 3.80  | 3.80   | 144.00  | 200.00  |
| Lodz             | 3.80  | 3.40   | 96.00   | 148.00  |
| Warsaw           | 4.40  | -  | 196.00  | 230.00  |
| <b>Minimum</b>   | <b>3.00</b>   | <b>3.00</b>  | <b>96.00</b>  | <b>117.00</b>   |

Source: Own study based on studied cities websites.

but it is also possible to make comparisons with other cities in Europe or worldwide. Certain rules should be obviously observed, most generally – compared cities should be similar in size, e.g. in terms of population. Also it is necessary to consider the fact that capital cities are cities of special political, administrative and economic situation. Numerous central offices have their seats there, but also entities operating on European and global, and not only on the national scale. This frequently translates into higher revenues of the city and population, into higher standards of services, and frequently also into higher prices.

The paper compares prices binding in the largest Polish cities (population in excess of 300,000 people). Table 1 specifies nominal prices of basic ticket types in the studied cities.

To illustrate the existing differences, the next Table 2 refers the nominal prices to the minimum, i.e. the lowest price of specific tickets in the studied group of cities. High diversification of nominal ticket prices is visible in studied cities. The price of single travel ticket in the urban zone in Warsaw is more than 46% higher than the cheapest similar ticket in Wroclaw and Bydgoszcz.

Comparison of nominal prices in the given city with the lowest ticket price (minimum)

Table 2

| Area/Ticket type | Difference between nominal price of single travel ticket in the urban zone and the minimum | Difference between nominal price of single travel time ticket (30-40 minutes) and the minimum | Difference between nominal price of a personal monthly ticket or 30-day ticket for the whole network and the minimum | Difference between nominal price of a bearer monthly ticket or 30-day ticket for the whole network and the minimum |
|------------------|--|---|--|--|
| Poznan           | -  | 53.3%   | 107.3%   | -  |
| Szczecin         | -  | 0.0%  | 68.8%  | 45.3%  |
| Bydgoszcz        | 0.0%   | -   | 25.0%  | 19.7%  |
| Wroclaw          | 0.0%   | 0.0%  | 2.1%   | 45.3%  |
| Katowice         | 3.3%   | 23.3%   | 50.0%  | 43.6%  |
| Gdansk           | 6.7%   | -   | 8.3%   | 0.0%   |
| Krakow           | 26.7%  | 26.7%   | 50.0%  | 70.9%  |
| Lodz             | 26.7%  | 13.3%   | 0.0%   | 26.5%  |
| Warsaw           | 46.7%  | -   | 104.2%   | 96.6%  |

Source: own study based on figures from Table 1.

Nominal prices have been compared, but also diversified economic potential of cities and diversified situation of residents, resulting from different obtained labour incomes, have been considered. The level of Gross Domestic Product (GDP) obtained in specific city or group of cities and the average gross salary were adopted as the basic differentiating measures for the given city or area. Those measures were used to calculate adjusted prices - nominal prices were corrected multiplying them by the value showing to what extent the mean GDP for analysed cities is higher or smaller than the given city GDP and in a similar way - to what extent the average gross salary for analysed cities is higher or smaller than the average salary of the given city. The adjusted prices were calculated acc. to the following formulae:

1. 
$$\text{Adjusted price} = \text{nominal price} \times \frac{\text{average GDP for the group of studied cities}}{\text{GDP for given city}}$$
2. 
$$\text{Adjusted price} = \text{nominal price} \times \frac{\text{average gross salary for the group of studied cities}}{\text{average gross salary for given city}}$$

Table 3 compares the studied cities in terms of their economic situation. GDP per capita and the average monthly gross salary in the given city in 2013 are specified in the table.

GDP per capita and the average monthly gross salary in studied cities in 2013

Table 3

| Area      | Annual GDP per capita (PLN) | Average monthly gross salary (PLN) |
|-----------|-----------------------------|------------------------------------|
| Bydgoszcz | 44,720.38                   | 3,554.43                           |
| Szczecin  | 50,437.07                   | 4,029.51                           |
| Lodz      | 53,402.63                   | 3,710.91                           |
| Katowice  | 59,623.28                   | 4,797.17                           |
| Gdansk    | 61,822.72                   | 4,481.04                           |
| Krakow    | 69,015.22                   | 3,997.80                           |
| Wroclaw   | 69,071.79                   | 4,129.56                           |
| Poznan    | 86,577.69                   | 4,256.82                           |
| Warsaw    | 126,618.82                  | 5,226.05                           |

Source: Regional Data Bank of the Central Statistical Office (RDB CSO) [7]

Nominal prices of basic ticket types in studied cities were adjusted by the GDP value acc. to formula 1. Results of analysis are specified in Table 4, presenting values reflecting ticket prices after the performed correction.

In Table 5 the obtained results are compared to the minimal value, i.e. the lowest adjusted price for the studied

Comparison of basic ticket prices adjusted by the GDP index for the given city/region

Table 4

| Area/<br>Ticket type | Price of single travel ticket in the urban zone (GDP adjusted) (PLN) | Price of single travel time ticket (30-40 minutes) (GDP adjusted) (PLN) | Price of a personal monthly ticket or 30-day ticket for the whole network (GDP adjusted) (PLN) | Price of a bearer monthly ticket or 30-day ticket for the whole network (GDP adjusted) (PLN) |
|----------------------|--|---|--|--|
| Poznan               | -  | 3.44  | 177.86   | -  |
| Szczecin             | -  | 3.85  | 248.54   | 258.21   |
| Warsaw               | 2.72   | -   | 119.78   | 139.16   |
| Wroclaw              | 3.40   | 2.81  | 109.79   | 188.55   |
| Gdansk               | 4.06   | -   | 130.17   | 144.98   |
| Katowice             | 4.07   | 4.02  | 186.89   | 215.86   |
| Krakow               | 4.31   | 3.57  | 161.46   | 222.00   |
| Bydgoszcz            | 5.26   | -   | 207.64   | 239.83   |
| Lodz                 | 5.58   | 4.13  | 139.11   | 212.31   |
| Minimum              | 2.72   | 2.81  | 109.79   | 139.16   |

Source: own study.

Comparison of adjusted ticket prices with the lowest adjusted ticket price (minimum) in the studied group of cities

Table 5

| Area/<br>Ticket type | Difference between nominal price of single travel ticket in the urban zone (GDP adjusted) and the minimum | Difference between nominal price of single travel time ticket (30-40 minutes) (GDP adjusted) and the minimum | Difference between nominal price of a personal monthly ticket or 30-day ticket for the whole network (GDP adjusted) and the minimum | Difference between nominal price of a bearer monthly ticket or 30-day ticket for the whole network (GDP adjusted) and the minimum |
|----------------------|---|--|---|---|
| Poznan               | -   | +22.4%   | +62.0%  | -   |
| Szczecin             | -   | +37.0%   | +126.4%   | +85.5%  |
| Warsaw               | <b>0.0%</b>   | -  | +9.1%   | 0.0%  |
| Wroclaw              | +25.0%  | <b>0.0%</b>  | <b>0.0%</b>   | +35.5%  |
| Gdansk               | +49.3%  | -  | +18.6%  | +4.2%   |
| Katowice             | +49.6%  | +43.1%   | +70.2%  | +55.1%  |
| Krakow               | +58.5%  | +27.0%   | +47.1%  | +59.5%  |
| Bydgoszcz            | +93.4%  | -  | +89.1%  | +72.3%  |
| Lodz                 | +105.1%   | +47.0%   | +26.7%  | +52.6%  |

Source: own study based on figures from Table 4.

cities. The carried out analysis shows e.g. that the highest nominal prices of single travel ticket in the urban zone exist in Warsaw, and then in Krakow and Lodz, and those of a personal monthly ticket or 30-day ticket valid for the whole network in Warsaw and Poznan. However, after the adjustment of nominal prices with the adopted GDP index it is possible to notice that - having considered the city economic situation - these relationships have changed. And so Warsaw ranks among the cheapest cities taking into account adjusted analysed ticket prices, Lodz and Bydgoszcz are cities, where

the single travel ticket prices in the urban zone are the highest after the adjustment made, and in Szczecin the adjusted monthly ticket prices are much higher than in the other cities.

It is also worth to refer ticket prices in the studies cities to the purchasing power of their residents. Table 6 specifies value reflecting ticket prices adjusted by the average monthly gross salary for the given city or subregion (depending on the data availability in the Central Statistical Office database). Table 7, like previous tables, compared the obtained results with the minimum value.

Comparison of basic ticket prices adjusted by the average monthly gross salary for the given city/subregion

Table 6

| Area/<br>Ticket type | Price of single travel ticket in the urban zone (adjusted by the average monthly gross salary) (PLN) | Price of single travel time ticket (30-40 minutes) (adjusted by the average monthly gross salary) (PLN) | Price of a personal monthly ticket or 30-day ticket for the whole network (adjusted by the average monthly gross salary) (PLN) | Price of a bearer monthly ticket or 30-day ticket for the whole network (adjusted by the average monthly gross salary) (PLN) |
|----------------------|--|---|--|--|
| Poznan               | -  | 4.50  | 205.25   | -  |
| Szczecin             | -  | 3.10  | 176.51   | 185.70   |
| Katowice             | 2.86   | 3.21  | 131.79   | 154.15   |
| Gdansk               | 3.16   | -   | 101.90   | 114.93   |
| Wroclaw              | 3.22   | 3.03  | 104.19   | 181.21   |
| Warsaw               | 3.73   | -   | 164.66   | 193.72   |
| Bydgoszcz            | 3.74   | -   | 148.23   | 173.37   |
| Krakow               | 4.21   | 3.96  | 158.15   | 220.21   |
| Lodz                 | 4.53   | 3.82  | 113.58   | 175.55   |
| <b>Minimum</b>       | <b>2.86</b>  | <b>3.03</b>   | <b>101.90</b>  | <b>114.93</b>  |

Source: own study.

Comparison of ticket prices adjusted by the average monthly gross salary with the lowest adjusted ticket price (minimum) in the studied group of cities

Table 7

| Area/<br>Ticket type | Difference between nominal price of single travel ticket in the urban zone (adjusted by the average monthly gross salary) and the minimum | Difference between nominal price of single travel time (30-40 minutes) (adjusted by the average monthly gross salary) and the minimum | Difference between nominal price of a personal monthly ticket or 30-day ticket for the whole network (adjusted by the average monthly gross salary) and the minimum | Difference between nominal price of a bearer monthly ticket or 30-day ticket for the whole network (adjusted by the average monthly gross salary) and the minimum |
|----------------------|---|---|---|---|
| Poznan               | -   | +48.5%  | +101.4%   | -   |
| Szczecin             | -   | +2.3%   | +73.2%  | +61.6%  |
| Katowice             | <b>0.0%</b>   | +5.9%   | +29.3%  | +34.1%  |
| Gdansk               | +10.5%  | -   | <b>0.0%</b>   | <b>0.0%</b>   |
| Wroclaw              | +12.6%  | <b>0.0%</b>   | +2.2%   | +57.7%  |
| Warsaw               | +30.4%  | -   | +61.6%  | +68.6%  |
| Bydgoszcz            | +30.8%  | -   | +45.5%  | +50.8%  |
| Krakow               | +47.2%  | +30.7%  | +55.2%  | +91.6%  |
| Lodz                 | +58.4%  | +26.1%  | +11.5%  | +52.7%  |

Source: own study based on figures from Table 6.

The comparison of nominal ticket prices with the purchasing power substantially changes relationships between the studied cities. Having considered the purchasing power, i.e. adjusting nominal prices by the average monthly gross salary index for the given city/subregion, it turns out that relatively high nominal ticket prices in such cities as Warsaw or Katowice become much lower compared to other cities. Therefore such comparison allows to make the carried out price analysis significantly more objective. A similar effect may be obtained counting the number of tickets, which can be purchased e.g. for the average salary in the given region (Table 8).

Table 8 shows that even in such a case as e.g. Warsaw, where ticket prices are higher, for the average remuneration for work in this city it is possible to buy more tickets than in other cities. Although in the other cities ticket prices are lower, but the proportion of salaries is so unfavourable, that allows to buy a smaller number of tickets, despite their lower price. The highest number of single travel tickets for the urban zone, for the average monthly salary, can be purchased in Katowice. In the case of studied season ticket types the most favourable relationship occurs in Gdansk.

In the case of studying urban transport prices in the largest Polish cities it is also very important to compare costs related

Number of tickets, which can be bought for the average monthly gross salary

Table 8

| Area/<br>Ticket type | Average monthly gross salary (PLN) | Single travel ticket in the urban zone | Single travel time ticket (30-40 minutes) | Personal monthly or 30-day ticket for the whole network | Bearer monthly or 30-day ticket for the whole network |
|----------------------|------------------------------------|--|---|---|---|
| Bydgoszcz            | 3,554.43                           | 1,185                                  | -   | 30  | 25  |
| Lodz                 | 3,710.91                           | 977                                    | 1,091                                     | 39  | 25  |
| Krakow               | 3,997.80                           | 1,052                                  | 1,052                                     | 28  | 20  |
| Szczecin             | 4,029.51                           | -                                      | 1,343                                     | 25  | 24  |
| Wroclaw              | 4,129.56                           | 1,377                                  | <b>1,377</b>                              | 42  | 24  |
| Poznan               | 4,256.82                           | -                                      | 925                                       | 21  | -   |
| Gdansk               | 4,481.04                           | 1,400                                  | -   | <b>43</b>   | <b>38</b>   |
| Katowice             | 4,797.17                           | <b>1,547</b>                           | 1,297                                     | 33  | 29  |
| Warsaw               | <b>5,226.05</b>                    | 1,188                                  | -   | 27  | 23  |
| <b>Maximum</b>       | <b>5,226.05</b>                    | <b>1,547</b>                           | <b>1,377</b>                              | <b>43</b>   | <b>38</b>   |

Source: Own study based on the RDB CSO data and studied cities websites.

Comparison of costs of travelling by a private car to the city centre and costs of parking the car with the basic ticket price in the urban public transport

Table 9

| City      | Charge for the first hour of parking (PLN) | Fuel cost to drive 5 km (PLN) | Total costs (fuel + parking charge) (PLN) | Basic ticket price (PLN) | Difference between basic ticket price and the total cost of travelling by a private car (PLN) |
|-----------|--|-------------------------------|---|--------------------------|---|
| Poznan    | 3  | 1.63                          | 4.63                                      | 4.6                      | -0.03   |
| Warsaw    | 3  | 1.63                          | 4.63                                      | 4.4                      | -0.23   |
| Katowice  | 2  | 1.63                          | 3.63                                      | 3.1                      | -0.53   |
| Krakow    | 3  | 1.63                          | 4.63                                      | 3.8                      | -0.83   |
| Lodz      | 3  | 1.63                          | 4.63                                      | 3.4                      | -1.23   |
| Gdansk    | 3  | 1.63                          | 4.63                                      | 3.4                      | -1.23   |
| Szczecin  | 2.8  | 1.63                          | 4.43                                      | 3                        | -1.43   |
| Bydgoszcz | 3  | 1.63                          | 4.63                                      | 3                        | -1.63   |
| Wroclaw   | 3  | 1.63                          | 4.63                                      | 3                        | -1.63   |

Source: Own study based on studied cities websites.

to travelling by a private car with ticket prices for the urban public transport. Table 9 specifies the costs of travelling to the city centre (the distance of 5 km was adopted), which include the cost of fuel and the cost of parking the car for one hour, as well as prices of basic tickets for the urban public transport binding in the given city.

The analysis of costs of travelling by a private car, performed in Table 8, considers only the fuel costs apart from the parking charge, and it is necessary to remember that an average cost of travelling by a private car is much higher than the fuel cost. Because the cost calculation should include depreciation, costs of regular maintenance, of repairs, car parking (e.g. garage), or the insurance costs. However, the marginal cost counts for the consumer and it is the cost of fuel purchase and the amount of parking charge, if related to the specific travel, which are most often considered by the consumer [6].

Table 9 shows that in each of studied cases the urban public transport, in terms of cost, was more competitive than the individual transport. From this point of view such cities as Wroclaw, Bydgoszcz, and also Szczecin, come out to be most favourable. Instead, Poznan and Warsaw are the cities, where the price competitiveness of the urban public transport was lowest against private cars. So taking into account a high diversification of studied cities and the fact that both Warsaw and Poznan are the cities of relatively high GDP and of relatively high average monthly salary, the amount of parking charge in the city centre may raise doubts. The amount of parking charge is almost the same in every studied city, which results from Polish regulations, which defined the maximum amount (PLN 3) for the first hour of parking on public road [8]. In this way the cities have limited possibilities to use this instrument within the pursued transport policy. This results, in

the context of various incomes of city residents and differing economic situation of cities, in particular the largest ones in Poland, in a situation that a real impact of paid parking in the city centres is weakened.

### 3. Conclusions

In contemporary economy the comparative studies are being more and more important, becoming one of main research methods, apart from induction and deduction. They create an opportunity to analyse economic phenomena in various systems and of various range. Comparative studies on prices are not an easy research task, because they require designing and applying measures or their aggregates, enabling to carry out as objective as possible assessment of phenomena and processes. The price analysis certainly requires to assess the change dynamics, to refer the price level to the economic situation as well as to carry out comparison between similar entities/units.

The comparison of ticket prices in the largest cities shows that the highest nominal prices of urban public transport tickets occur in Warsaw, Lodz and Krakow, and the lowest in Bydgoszcz and Wroclaw. However, a true picture of those prices amount is provided only by the comparison of ticket prices with the purchasing power and with the economic situation. In this context, having considered the purchasing power, the highest burden of ticket prices for residents exists in Lodz, Krakow and Bydgoszcz. Despite the lowest nominal prices in the studied group the burden in Bydgoszcz is among the highest ones. Instead Warsaw, despite the highest nominal ticket prices, is in the group of cities, where ticket prices,

taking into account the purchasing power and economic situation, are relatively the lowest.

In the comparative analysis it is also very important to make a comparison with substitute goods and services. So when studying the prices of urban public transport in cities it is necessary to refer to travelling by private cars, i.e. substitute services for the public transport. In this case it is most appropriate to compare prices of single travel tickets, intended for persons seldom using the public transport, with costs of fuel and parking charges. In all studied cities the use of urban public transport is cheaper than travelling by car, which should

be positively evaluated. However, the maximum amount of parking charges, regulated in Polish legislation, is the element substantially limiting actions of cities to improve the urban public transport attractiveness against private cars.

Comparative studies on prices can be a significant element of the policy pursued by the studied cities in the field of shaping the public transport prices. The carried out analysis shows also how important it is to consider – in comparative studies of prices, including the urban transport prices – the macroeconomic factors, which can substantially change the perspective of economic phenomena assessment.

## References

- [1] SMALL, K. A., VARHOEF, E. T.: *The Economics of Urban Transportation*, Routledge (2007)
- [2] HENSHER, D.A., BREWER A.M.: *Transport: An Economics and Management Perspective*. Oxford University Press : New York, 2001
- [3] BUTTON, K.: *Transport Economics*, Edward Elgar Publishing Ltd. (2010)
- [4] WYSZOMIRSKI, O. (ed.): *People's Travels in Cities* (in Polish). *Ekonomika i organizacja*, Wyd. Uniwersytetu Gdanskiego : Gdansk, 2008
- [5] TAE HOON OUM: *Transport Economics*, Taylor & Francis, 1997
- [6] TOMANEK, R. (ed.): *Prices of People's Travels in Cities in Europe* (in Polish), *Prace Naukowe Akademii Ekonomicznej*, Katowice, 2007
- [7] Regional Data Bank of the Central Statistical Office [www.stat.gov.pl](http://www.stat.gov.pl) [date of access: 10 October, 2016]
- [8] The Act on Public Roads as of 21 March 1985, *J. of Laws of 1985*, No. 14, item 60 with later amendments.

Branislav Sarkan - Ondrej Stopka - Chenguang Li\*

## THE ISSUES OF MEASURING THE EXTERIOR AND INTERIOR NOISE OF ROAD VEHICLES

*Nowadays, within the issues of road vehicles operation, we place great emphasis especially on the most important operating characteristics such as fuel consumption, exhaust emissions as well as performance indicators. However, in the field of driving comfort, a noise inside the vehicle, affecting its crew, represents an important aspect as well. The paper analyzes the interior and exterior vehicle noise, methods of its detection and practical research measurement indicating the rate of interior vehicle noise during various traffic conditions.*

**Keywords:** Exterior noise, interior noise, road vehicle, measurement, vehicle operation, traffic.

### 1. Introduction

Noise represents a special position among several negative environmental factors and unfavorable, even damaging, human effects. Nowadays, risk evaluation of noise exposure represents extremely urgent issue due to the enormous increase in acoustic energy in the environment. Road transport has the largest share in generating the traffic noise. Thus, road traffic noise is one of the fundamental reasons considered within the contact human - transport [1 and 2].

Below mentioned basic terms define and directly specify the noise as an objectionable environmental sound causing even annoying feeling that has generally an unfavorable effect [2 - 4]: (1) **Noise** - every unwanted, intrusive, annoying or harmful sound that causes the biological reaction of humans and animals; (2) **The Noise Level ( $LA$ ) in dB** - the level of acoustic pressure weighted using the weighting filter  $A$ ; (3) **The Percentage Noise Level** - the sound level with  $A$  weighting obtained during the weighing time function  $F$  (fast), exceeded in percentage of the total evaluation period. Denotation -  $LN$  (e.g. L1,10,50,90,99); (4) **The Equivalent Noise Level ( $LA_{eq}$ ) in dB** - is consistent data that is used to describe the sound course with a varying sound level which includes the road traffic noise as well. It is calculated as an acoustic pressure which is energetically equivalent to the long-term effect of intermittent noise or noise with a varying sound level.

### 2. Legislation relating to the field of measuring the road vehicles noise

In the beginning of the legislative framework analysis relating to the issue of road vehicles noise, it is important to mention the basic divisions of road vehicles noise which are regulated by different legislative rules either in the field of road vehicles approval, or the operation itself [5].

The field of road vehicles noise [4 and 5]: (1) inside the vehicle - interior noise; (2) noise outside the vehicle - exterior noise.

In terms of the road vehicle operation, it is possible to measure the interior and exterior noise [5]: (1) standing vehicle (idle engine speed or increased engine speed); (2) vehicle in motion (different vehicle speeds, acceleration).

The reason for measuring the road vehicle noise [3 and 5]: (1) road vehicles approval; (2) tests in operation; (3) other (research-development testing, etc.).

The basic legislative frameworks contain various combinations of these types of tests. For example, during the type-approval of road vehicles, the exterior noise of the standing vehicle as well as the vehicle in motion is measured. On the contrary, during the technical control of road vehicle in its operation, technician, in the technical inspection station (TIS), only measures the vehicle exterior noise standing at increased engine speed (revolutions per minute).

\* <sup>1</sup>Branislav Sarkan, <sup>2</sup>Ondrej Stopka, <sup>3</sup>Chenguang Li

<sup>1</sup>Department of Road and Urban Transport, Faculty of Operation and Economics of Transport and Communications, University of Zilina, Slovakia

<sup>2</sup>Department of Transport and Logistics, Faculty of Technology, Institute of Technology and Business in Ceske Budejovice, Czech Republic

<sup>3</sup>School of Economics and Management, North China University of Technology, Beijing, China

E-mail: branislav.sarkan@fpedas.uniza.sk

### 2.1. Council Directive 70/157/EEC

Council Directive 70/157/EEC of 6 February 1970 on the approximation of the laws of the Member States relating to the permissible sound level and the exhaust system of motor vehicles. Since its adoption, this Directive was repeatedly substantially amended. The latest reduction in sound level limits for motor vehicles in 1995 did not bring the desired effect. Studies have shown that a test method used by the Directive, did not reflect the true nature of driving in urban traffic any longer. As pointed out in the Green Paper on a future policy on noise since November 4, 1996, in the test method, the contribution of a tire rolling noise to the total noise emission was underestimated. This directive refers to the Regulation of the United Nations Economic Commission for Europe (UNECE) no. 51 on noise emissions, setting out a test method for noise emissions, and the Regulation of the UNECE no. 59 on provisions concerning the approval of replacement silencing systems [6 - 8].

According to this directive, the following vehicles are controlled [6 - 8]:

- standing vehicle - measurement is carried out according to this directive requirements (noise meter microphone placement) at different engine speeds. The result is logged to the vehicle registration certificate and is the basis for the vehicle test in operation.
- vehicle in motion - measurement is carried out according to this directive specific requirements. The result of this test must meet the prescribed limits defined by this directive for specific categories of road vehicles. According to this directive, the measured noise values of the standing vehicle and vehicle in motion are logged into the vehicle registration certificate as well.

### 2.2. Regulation of the European Parliament and of the Council (EU) no. 540/2014

Regulation of the European Parliament and of the Council (EU) no. 540/2014 of 16 April 2014 on the sound level of motor vehicles and of replacement silencing systems, and amending the Directive 2007/46/EC and repealing the Directive 70/157/EEC. Thus, this regulation should introduce a test method that is different from the method set out in the Directive 70/157/EEC. The new method should be based on the test method published in 2007 by the UNECE Working Party on Noise (GRB) and into which the version of the ISO standard 362 in 2007 has been incorporated. The results of monitoring both the old and the new test methods were submitted to the Commission. This regulation brought a tightening noise limits for the type-approval of road vehicles. The process of gradual reduction of environmental burden by the road vehicles operation is planned in the various phases up to 2026 [7 and 8].

### 3. Practical measurements

Practical measurements were carried out on a selected group of road passenger vehicles with the parameters defined in Table 1. For those vehicles, permitted or measured levels of exterior noise of a standing vehicle and vehicle in motion are indicated in the vehicle registration certificate according to the Council Directive 70/157/EEC [6, 8 and 9].

#### 3.1. Exterior noise of the vehicle in motion

For a selected group of vehicles, exterior noise level was measured according to the “Methodology” defined in the Council Directive 70/157/EEC. 3 measurements for each

Used vehicles during the practical measurement

Table 1

| Vehicle brand | Trade name | Engine capacity (cm <sup>3</sup> ) | Production year | Maximum engine performance (kW/min <sup>-1</sup> ) | Fuel type | Level of exterior noise of a standing vehicle (dB/rpm <sup>-1</sup> ) | Level of exterior noise of a vehicle in motion (dB) |
|---------------|------------|------------------------------------|-----------------|--|-----------|---|---|
| Skoda         | Octavia    | 1896                               | 2008            | 77/4000  | Diesel    | 79/3000   | 69  |
| VW            | Passat     | 1896                               | 1996            | 81/4150  | Diesel    | 83/3113   | 72  |
| Renault       | Thalia     | 1149                               | 2007            | 55/5500  | Petrol    | 82/4125   | 70  |
| Opel          | Zafira     | 1995                               | 2004            | 74/4000  | Diesel    | 77/3000   | 72  |
| Opel          | Vectra     | 1598                               | 1996            | 74/6200  | Petrol    | 83/4650   | 73  |
| Mazda         | 323        | 1840                               | 2000            | 84/6000  | Petrol    | 86/4500   | 73  |
| Peugeot       | 206        | 1868                               | 1998            | 51/4600  | Diesel    | 86/3450   | 72  |
| Skoda         | Felicia    | 1289                               | 2001            | 50/5000  | Petrol    | 78/3750   | 73  |
| Renault       | Clio       | 1390                               | 1997            | 55/5750  | Petrol    | 84/4313   | 75  |

Source: authors

Noise emission limits during the test of the vehicle in motion

Table 2

| Vehicle           | Exterior noise of the vehicle in motion |                   |                             |                   |                             |                   | Methodology (dB) | Difference between the highest measured value and the „Methodology“ value (dB) |
|-------------------|---|-------------------|-----------------------------|-------------------|-----------------------------|-------------------|------------------|--|
|                   | 1 <sup>st</sup> measurement             |                   | 2 <sup>nd</sup> measurement |                   | 3 <sup>rd</sup> measurement |                   |                  |  |
|                   | Left side dB (A)                        | Right side dB (A) | Left side dB (A)            | Right side dB (A) | Left side dB (A)            | Right side dB (A) |                  |  |
| Volkswagen Passat | 72.8                                    | 72.6              | 72.8                        | 72.6              | 71.8                        | 72                | 72               | 0.8  |
| Skoda Octavia     | 69                                      | 69.2              | 68                          | 68.5              | 68.5                        | 68.7              | 69               | 0.2  |
| Renault Thalia    | 70                                      | 69.8              | 70.5                        | 70.3              | 71                          | 71.2              | 70               | 1.2  |
| Opel Zafira       | 72.3                                    | 72.4              | 72                          | 72.1              | 71.8                        | 72                | 72               | 0.4  |
| Opel Vectra       | 77                                      | 77.1              | 76.9                        | 76.8              | 76.9                        | 77                | 73               | 4.1  |
| Mazda 323         | 70.1                                    | 69.9              | 70.7                        | 70.5              | 71                          | 69.9              | 73               | -2   |
| Peugeot 206       | 71.5                                    | 71.9              | 72.9                        | 72.6              | 72.3                        | 72.4              | 72               | 1.9  |
| Skoda Felicia     | 71.9                                    | 71.9              | 71.8                        | 71.7              | 72                          | 71.9              | 73               | -1   |
| Renault Clio      | 74.5                                    | 74.4              | 74.9                        | 74.8              | 73.5                        | 73.7              | 75               | -0.1   |

Source: authors

vehicle were carried out with a requirement of the noise measuring on the vehicle left and the right side [6, 8 and 10].

A microphone must be placed at a distance of 7.5 m +/- 0.2 m from a reference line of the roadway and 1.2 m +/- 0.1 m above the ground. Its axis of maximum sensitivity must be horizontal and perpendicular to the vehicle roadway. When the vehicle front reaches the specific line, the accelerator fully opens as quickly as possible and is held in the fully opened position, until the rear vehicle intersects another specific line. Then, the accelerator closes as quickly as possible [11 - 13].”

The measured values are compared with the “Methodology” and listed in following Table 2.

### 3.2. Exterior noise of the standing vehicle

A microphone is placed at a distance of 0.5 m ± 0.01 from a reference point of the exhaust pipe and at angle of 45° (± 5°) to the vertical level in which the exhaust flow axis at the exhaust pipe outlet is placed. A microphone must be placed at a reference point, however, no less than 0.2 m from the ground surface. The microphone reference axis must be placed in a level parallel to the ground surface and must be directed to the reference point at the exhaust pipe outlet [11, 14 and 15].

Noise emission limits during the test of the standing vehicle are listed in following Table 3.

According to the Council Directive 70/157/EEC, it is necessary to measure the noise emissions of the standing vehicle for the selected vehicles at engine speed equal to ¾ of

Noise emission limits during the test of the standing vehicle

Table 3

| Vehicle           | Exterior noise of the vehicle in motion |                   |                             |                   |                             |                   | Methodology (dB) | Difference between the highest measured value and the „Methodology“ value (dB) |
|-------------------|---|-------------------|-----------------------------|-------------------|-----------------------------|-------------------|------------------|--|
|                   | 1 <sup>st</sup> measurement             |                   | 2 <sup>nd</sup> measurement |                   | 3 <sup>rd</sup> measurement |                   |                  |  |
|                   | Left side dB (A)                        | Right side dB (A) | Left side dB (A)            | Right side dB (A) | Left side dB (A)            | Right side dB (A) |                  |  |
| Volkswagen Passat | 66.8                                    | 71.6              | 76.4                        | 86.5              | 83                          | 3.5               | 66.8             | 71.6   |
| Skoda Octavia     | 59.8                                    | 63.3              | 70.5                        | 78.7              | 79                          | -0.3              | 59.8             | 63.3   |
| Renault Thalia    | 54                                      | 66                | 71                          | 81.5              | 82                          | -0.5              | 54               | 66   |
| Opel Zafira       | 57                                      | 63.5              | 71.5                        | 76.8              | 77                          | -0.2              | 57               | 63.5   |
| Opel Vectra       | 57                                      | 65                | 77.3                        | 86.5              | 83                          | 3.5               | 57               | 65   |
| Mazda 323         | 59.2                                    | 63.6              | 79                          | 85                | 86                          | -1                | 59.2             | 63.6   |
| Peugeot 206       | 61.6                                    | 67.4              | 84                          | 93.3              | 86                          | 7.3               | 61.6             | 67.4   |
| Skoda Felicia     | 65.2                                    | 67.9              | 70.3                        | 77.4              | 78                          | -0.6              | 65.2             | 67.9   |
| Renault Clio      | 58.9                                    | 63                | 67.1                        | 84.5              | 84                          | 0.5               | 58.9             | 63   |

Source: authors and [6]

rated engine speed. In this case, the test is extended to noise emission values at idle engine speed and engine speed of 1000 rpm and 2000 rpm. The highest noise value exceeding the limit specified by this directive is achieved by Peugeot 206 [11, 14 and 15].

### 3.3. Comparison of exterior and interior noise of the vehicle in motion

A vehicle comfort level with respect to its noise on the passengers could be evaluated not only through the interior vehicle noise at a point of the driver's right organ of hearing, but also determining the "reduction rate of exterior noise into the vehicle passenger cab" [3, 9 and 16].

The individual measured and recorded values are summarized in Table 4.

Comparison of exterior and interior noise of the vehicle in motion Table 4

| Vehicle           | Maximum exterior noise (dB) | Maximum interior noise (dB) | Difference (dB) |
|-------------------|-----------------------------|-----------------------------|-----------------|
| Volkswagen Passat | 72.8                        | 67.9                        | 4.9             |
| Skoda Octavia     | 69.2                        | 64                          | 5.2             |
| Renault Thalia    | 71.2                        | 83.3                        | 12.1            |
| Opel Zafira       | 72.4                        | 64.6                        | 7.8             |
| Opel Vectra       | 77.1                        | 74.5                        | 2.6             |
| Mazda 323         | 71                          | 68.6                        | 2.4             |
| Peugeot 206       | 72.9                        | 68.8                        | 4.1             |
| Skoda Felicia     | 72                          | 67.3                        | 4.7             |
| Renault Clio      | 74.9                        | 63                          | 11.9            |

Source: authors

Diametrically opposed values of the interior noise of Renault Thalia and Renault Clio are quite interesting. Inside

the vehicle Renault Thalia, the interior noise level is of 12.1 db higher compared to the exterior noise produced by this vehicle. As for Renault Clio, the lowest detected value of interior noise level of 63 db is equivalent to the exterior noise reduction by 11.9 dB.

Paradox of the vehicles Renault Thalia, with the high interior noise level, could be caused by [17 and 18]:

- insufficient soundproofing from the engine compartment,
- insufficient soundproofing from the vehicle undercarriage (chassis).

Individual values from the comparison of exterior and interior noise of the vehicle in motion are summarized in Table 3.

### 3.4. Comparison of exterior and interior noise of the standing vehicle

The comparison of the standing vehicle exterior and interior noise at various levels of engine speed (idle engine speed, 1000 rpm, 2000 rpm and ¼ of rated engine speed) can be considered as a test with a greater degree of explanatory value.

The measured noise level data can be assessed in two ways [12 and 19]:

- by evaluation of the absolute values,
- by evaluation of the exterior noise reduction (difference, ratio, etc.).

The comparison of exterior and interior noise of the standing vehicle is shown in Table 5.

From the detected noise values summarized in Table 5, the increase rate of the exterior and interior noise of the standing vehicle can be calculated as well. Evidently, Peugeot 206 is the noisiest vehicle in terms of the interior as well as exterior noise. An enormous noise increase, when increasing

Comparison of exterior and interior noise of the standing vehicle Table 5

| Vehicle           | Noise (dB)        |            |            |            |            |            |            |            |            |                         |            |            |
|-------------------|-------------------|------------|------------|------------|------------|------------|------------|------------|------------|-------------------------|------------|------------|
|                   | Idle engine speed |            |            | 1000 rpm   |            |            | 2000 rpm   |            |            | ¼ of rated engine speed |            |            |
|                   | Ext. noise        | Int. noise | Difference | Ext. noise | Int. noise | Difference | Ext. noise | Int. noise | Difference | Ext. noise              | Int. noise | Difference |
| Volkswagen Passat | 66.8              | 61.2       | 5.6        | 71.6       | 70         | 1.6        | 76.4       | 72.2       | 4.2        | 86.5                    | 74.2       | 12.3       |
| Skoda Octavia     | 59.8              | 52.6       | 7.2        | 63.3       | 63.4       | 0.1        | 70.5       | 66.3       | 4.2        | 78.7                    | 65         | 13.7       |
| Renault Thalia    | 54                | 58         | 4.0        | 66         | 66.3       | 0.3        | 71         | 66.3       | 4.7        | 81.5                    | 76         | 5.5        |
| Opel Zafira       | 57                | 53.5       | 3.5        | 63.5       | 62.5       | 1.0        | 71.5       | 61         | 10.5       | 76.8                    | 63.9       | 12.9       |
| Opel Vectra       | 57                | 47.4       | 9.6        | 65         | 65.1       | 0.1        | 77.3       | 71         | 6.3        | 86.5                    | 80         | 6.5        |
| Mazda 323         | 59.2              | 52.2       | 7.0        | 63.6       | 55.9       | 7.7        | 79         | 77.2       | 1.8        | 85                      | 81         | 4.0        |
| Peugeot 206       | 61.6              | 58.8       | 2.8        | 67.4       | 63.4       | 4.0        | 84         | 78.3       | 5.7        | 93.3                    | 91.6       | 1.7        |
| Skoda Felicia     | 65.2              | 61.1       | 4.1        | 67.9       | 64.2       | 3.7        | 70.3       | 69.9       | 0.4        | 77.4                    | 72.8       | 4.6        |
| Renault Clio      | 58.9              | 49.9       | 9.0        | 63         | 61.7       | 1.3        | 67.1       | 60.1       | 6.0        | 84.5                    | 79.2       | 5.3        |

Source: authors

the engine speed, can be seen as well. On the contrary, Opel Zafira is considered to be the least noisy vehicle based on the performed measurements. At the rated engine speed, it is able to reduce the vehicle interior noise by 12.9 dB compared to the exterior noise.

#### 4. Noise measurements in the technical inspection station

In normal operation of road vehicles, their noise level can be controlled in the technical inspection stations. Exterior noise level of the standing vehicle is measured according to the Methodical instruction No. 77/2011 [20].

Exterior noise level of the standing vehicle is assessed by the inspection technician subjectively, **without using a sound level meter**. If inspection technician, on the basis of his subjective judgment, cannot clearly assess whether the exterior noise level is not higher than the permissible value, he carries out the particular measurement [6, 21 and 22].

The resulting measured data is compared with a reference value. The reference value is determined from the data on the standing vehicle exterior noise level indicated in a given vehicle registration certificate plus a tolerance of + 5 dB (A) [22 - 24].

From the analyzed road vehicle group, Peugeot 206 does not meet a prescribed procedure of the inspection. It exceeds the value indicated in a vehicle registration certificate by 7.3 dB. In this case, if the measured exterior noise level value of the standing vehicle is higher than the permissible value, the vehicle is evaluated as "B" (temporarily fit for traffic) during the technical inspection. This means that the vehicle must be returned for performing the technical inspection within 30 days.

#### References

- [1] MELO, R. A., PIMENTEL, R. L., LACERDA, D. M., SILVA, W. M.: Applicability of Models to Estimate Traffic Noise for Urban Roads, *J. of Environmental Health Science and Engineering*, vol. 13, No. 83, 2015, ISSN 2052-336X, DOI: 10.1186/s40201-015-0240-9.
- [2] GOGOLA, M., VETERNIK, M.: The Analysis of the Environmental Impact of Road Traffic in City of Martin, *Logi - Scientific J. on Transport and Logistics*, vol. 7, No. 1, 2016, 49-60, ISSN 1804-3216.
- [3] DURCANSKA, D., et al.: *Assessment of Roads and Highways Impacts on the Environment - Noise and Emissions from Road Transport* (in Slovak), University of Zilina : EDIS, 2002, ISBN 80-8070-029-X.
- [4] MARUYAMA, M., KUNO, K., SONE, T.: New Mathematical Model to Estimate Road Traffic Noise in View of the Appearance Rate of Heavy Vehicles, *International J. of Acoustics and Vibration*, vol. 16, No. 2, 2011, 64-71, ISSN 1027-5851.
- [5] JANCZUR, R., WALERIAN, E., CZECHOWICZ, M.: Road Model as a Noise Source, *Acta Acustica United with Acustica*, vol. 95, No. 1, 2009, 156-167, ISSN 1610-1928, DOI: 10.3813/AAA.918137.
- [6] COUNCIL DIRECTIVE 70/157/EEC On the approximation of the laws of the Member States relating to the permissible sound level and the exhaust system of motor vehicles, 1970.
- [7] REGULATION OF THE EUROPEAN PARLIAMENT AND OF THE COUNCIL (EU) NO. 540/2014 on the sound level of motor vehicles and of replacement silencing systems, and amending Directive 2007/46/EC and repealing Directive 70/157/EEC, 2014.

#### 5. Conclusions

The issues of measuring the noise of road vehicles can be considered broadly comprehensive and highly topical. A lot of experts at international level deal with this field of study. The group known as "GBR" (Working Group on Noise from Road Vehicles), which is part of the World Forum for the Harmonization of Vehicle Regulations (WP.29) - part of the inland transport committee in the European Economic Community, represents an illustrative example [2, 8 and 25].

The processed article reports, inter alia, an overview of the exterior noise of road transport vehicles evaluation which is considered to be a part of the vehicle approval tests. A special attention is paid to the noise inside the vehicle. When purchasing the vehicle, its common a future user has available an amount of data about the required vehicle (performance, fuel consumption, parameters, etc.), however, an important detail regarding the comfort inside the vehicle is not available for him. This parameter is represented by the interior noise affecting the vehicle crew, especially the vehicle driver [26 and 27].

Authors of this paper predict that this issue of measurement and evaluation of vehicle interior noise will be readily available and important criterion concerning the vehicle selection in the future.

#### Acknowledgement

This paper has been developed under the support of: National Natural Science Foundation of China (No. 71503011) and Beijing Social Science Foundation of China (No. 16GLC041).

- [8] VEHICLE REGULATIONS - TRANSPORT - UNECE. *World Forum for the harmonization of vehicle regulations (WP.29)*, [Electronic source]. [Citation 2016-09-21]. 2016. Accessible via: <<http://www.unece.org/trans/main/welcwp29.html>>.
- [9] VIJAY, R., KORI, C., KUMAR, M., CHAKRABARTI, T., GUPTA, R.: Assessment of Traffic Noise on Highway Passing from Urban Agglomeration, *Fluctuation and Noise Letters*, vol. 13, No. 4, 2014, ISSN 0219-4775, DOI: 10.1142/S021947751450031X.
- [10] KINDT, P., BERCKMANS, D., DE CONINCK, F., SAS, P., DESMET, W.: Experimental Analysis of the Structure-Borne Tyre/Road Noise Due to Road Discontinuities, *Mechanical Systems and Signal Processing*, vol. 23, No. 8, 2557-2574, 2009, ISSN 0736-2501, DOI: 10.1016/j.ymssp.2009.04.005.
- [11] DISTEFANO, N., LEONARDI, S.: Experimental Investigation of the Effect of Speed Bumps in Sequence on Noise Emission Level from Motor Vehicles, *Noise Control Engineering J.*, vol. 63, No. 6, 2015, 582-597, ISSN 0736-2501.
- [12] WENTZEL, R.E., AUBERT, A.: *Using a Dynamometer Along with Road Tests to Measure Vehicle Rolling and Wind Noise*, Proc. of Noisecon/ASME NCAD-2008 - Noise-Control 2008/Sound Quality Symposium/30th Annual Conference of ASME Noise Control and Acoustics Division, Dearborn, Michigan, 2009, 201-206, ISBN 978-0-7918-4839-5.
- [13] BRAND, S., PETRI, M., HAAS, P., KRETTEK, C., HAASPER, C.: Hybrid and Electric Low-Noise Cars Cause an Increase in Traffic Accidents Involving Vulnerable Road Users in Urban Areas, *Intern. J. of Injury Control and Safety Promotion*, vol. 20, No. 4, 2013, 339-341, ISSN 1745-7300, DOI: 10.1080/17457300.2012.733714.
- [14] JU, H., HUANG, X., YU, X.: Influence of Traffic Regulation Factors on Noise in Ordinary Urban Roads, *Dongnan Daxue Xuebao (Ziran Kexue Ban)/J. of Southeast University (Natural Science Edition)*, vol. 44, No. 2, 2014, 420-424, ISSN 1001-0505, DOI: 10.3969/j.issn.1001-0505.2014.02.034.
- [15] HEUTSCHI, K., BUHLMANN, E., OERTLI, J.: Options for Reducing Noise From Roads and Railway Lines, *Transportation Research Part A: Policy and Practice*, vol. 94, 2016, 308-322, ISSN 0965-8564, DOI: 10.1016/j.tra.2016.09.019.
- [16] CHEER, J., ELLIOTT, S. J.: The Design and Performance of Feedback Controllers for the Attenuation of Road Noise in Vehicles, *Intern. J. of Acoustics and Vibration*, vol. 19, No. 3, 2014, 155-164, ISSN 1027-5851.
- [17] KUMAR, P., NIGAM, S. P., KUMAR, N.: Vehicular Traffic Noise Modeling Using Artificial Neural Network Approach, *Transportation Research Part C: Emerging Technologies*, vol. 40, 2014, 111-122, ISSN 0968-090X, DOI: 10.1016/j.trc.2014.01.006.
- [18] CAI, M., WANG, H.B., YU, Z., DING, J.L.: Road Traffic Noise Study for a House Community Based on Microscopic Traffic Simulation, *Zhendong yu Chongji/J. of Vibration and Shock*, vol. 32, No. 24, 2013, 48-55, ISSN 1000-3835.
- [19] CHEN, Y. G., YANG, Y. S., JIAN, S. X.: *Research of the Spread and Measurement of Urban Traffic Noise*, *Applied Mechanics and Materials*, vol. 684, 2014, 240-244, International Conference on Mechanics and Mechanical Engineering, MME 2014, Wuhan, September 2014, ISSN 1660-9336, DOI: 10.4028/www.scientific.net/AMM.684.240.
- [20] METHODOICAL INSTRUCTION NO. 77/2011 Establishing the control operations relating to the burden of the environment by the exhaust emissions, sound emissions and radio interference of vehicles performed during the vehicles technical control (Control operations of the group 800 (in Slovak), 2011.
- [21] MARISCAL-RAMIREZ, J. A., FERNANDEZ-PRIETO, J. A., CANADA-BAGO, J., GADEO-MARTOS, M. A.: A New Algorithm to Monitor Noise Pollution Adapted to Resource-Constrained Devices, *Multimedia Tools and Applications*, vol. 74, No. 21, 2015, 9175-9189, ISSN 1380-7501, DOI: 10.1007/s11042-014-2074-3.
- [22] LABUDA, R., KOVALCIK, A., REPKA, J., HLAVNA, V.: Simulation of a Wheeled Vehicle Dynamic Regimes in Laboratory Conditions, *Communications - Scientific Letters of the University of Zilina*, vol. 14, No. 3, 2012, 5-9. ISSN 1335-4205.
- [23] PALLAS, M. A., BERENGIER, M., CHATAGNON, R., CZUKA, M., CONTER, M., MUIRHEAD, M.: Towards a Model for Electric Vehicle Noise Emission in the European Prediction Method CNOSSOS-EU, *Applied Acoustics*, vol. 113, 2016, 89-101, ISSN 0003-682X, DOI: 10.1016/j.apacoust.2016.06.012.
- [24] TOMASIKOVA, M., LUKAC, M., CABAN, J., BRUMERCIK, F.: Controllability and Stability of a Vehicle, *Logi - Scientific J. on Transport and Logistics*, vol. 7, No. 1, 2016, 136-142, ISSN 1804-3216.
- [25] WEBER, S.: Spatio-temporal Covariation of Urban Particle Number Concentration and Ambient Noise, *Atmospheric Environment*, vol. 43, No. 34, 2009, 5518-5525, ISSN 1352-2310, DOI: 10.1016/j.atmosenv.2009.06.055.
- [26] GNAP, J., KALASOVA, A., GOGOLA, M., ONDRUS, J.: The Centre of Excellence for Transport Service and Control, *Communications - Scientific Letters of the University of Zilina*, vol. 12, No. 3 A, 2010, 116-120, ISSN 1335-4205.
- [27] MARUYAMA, M., KUNO, K., SONE, T.: Minimum Measurement Time Interval to Estimate a Reliable Sound Pressure Level of Road Traffic Noise Using Two Types of Dynamic Statistics, *Applied Acoustics*, vol. 83, 2014, 150-155, ISSN 0003-682X, DOI: 10.1016/j.apacoust.2014.03.007.

Mariana Strenitzerova - Miriam Garbarova\*

---

## IDENTIFICATION OF THE BARRIERS TO BUSINESS IN SLOVAKIA

*Barriers are the problems with which every company meets. These problems affect companies negatively. The aim of this paper is to identify major barriers in selected industry of the Slovak business environment. To fulfill the aim of the paper, a primary research, based on the methods of querying, analysis, comparison and selection, was conducted. The questionnaire was focused on identifying barriers in the Slovak business environment from the view of advertising agencies operating in the Zilina region. We can conclude that respondents can be divided into three groups: companies whose business is affected by the barriers, companies whose business is partly influenced by barriers, companies whose business is not affected by the barriers. We can deduce, according to respondents, that the main barrier to business is represented by the work of public administrative bodies.*

**Keywords:** Advertising agencies, business environment, internal barriers, external barriers.

### 1. Introduction

The current period is characterized by many changes. Constantly creating new products, new markets bring new opportunities but also threats. Each company tries to cope with the competitive environment and deliver the best possible competitive position. For success in business areas is not enough to accurately know business' environment. Achieved business results are diverse in market environment. Business success is contingent upon the choice and implementation of strategies for maintaining and growth of competitiveness. An appropriately chosen strategy leads to the proper direction of the company, or, at the time of corporate crisis to save the company itself [1].

Every company meets with a problem which negatively affects its business results. Such problems are referred to as barriers and can be so serious that will require plenty of time and cost to remove them. On the other hand, there are barriers that hardly affect the company. It depends on whether a company is fully prepared to start a business, if it has a capable manager who can advise in such situations or if it is an experienced company. In fact, every company depends on the set of managerial decisions and actions by which network management determines in advance what should be accomplished and how it should be achieved [2]. Therefore, it is necessary to report every important activity of

the company. This is compounded by the fact that companies face the increased demand for information about them [3]. It is important to realize that companies can exist in various forms, which is a feature that has impact on company's effort to create something new or to improve something what already exists. Also, actions of every company are externally assessed, which promotes its reputation [4].

The aim of the paper is to identify major barriers in selected industry of the Slovak business environment. The paper consists of four parts. An input to the problem and theoretical definitions of internal and external barriers in the business are included in introduction. Methodology describes paper's creation process and methods used to fulfill the aim of the paper. Results part comprises primary research aimed at identifying major barriers in Slovak advertising industry. The last part - conclusion - evaluates the results of primary research.

### 2. Theoretical background

Since companies are making significant means for acquiring and preserving information, the lack of information certainly isn't one of the most serious problems of present days [5]. The driving forces behind success of a company are not only information and technologies but even broader

---

\* Mariana Strenitzerova - Miriam Garbarova

Department of Communications, Faculty of Operation and Economics of Transport and Communications, University of Zilina, Slovakia  
E-mail: mariana.strenitzerova@fpedas.uniza.sk

term - innovations [6]. A positive fact is that nowadays, companies are even more successful in overcoming major barriers to innovation [7]. Perfect market does not exist and anyone who wants to start a business must carve out its place in the market. In every country, there are not only barriers to the development of business environment but even efforts to remove them. In accordance with a primary classification, barriers to business are divided into internal barriers and external barriers.

### 2.1 Internal barriers to business

Internal barriers to business are conceptual barriers to company's progress which are represented by the lack of interest, lack of opportunity and/or lack of capacity. These barriers affect issues around perceived risk, competing priorities, internal support and skills [8]. Internal barriers to business are numerous, multi-dimensional, interdependent and are categorized into three clusters [9]:

- a) **Opportunity cost of investment:** When companies consider investing, they compare the expected rates of return with those of alternative investments they could make. Companies may wait and grow into base of the pyramid markets by acquiring small companies that are successful. These circumstances make it difficult for decision-makers to justify the opportunity cost of investing when other investments with higher, more certain rates of return are available.
- b) **Strategic and operational misalignment:** Every company is a matter of procuring, manufacturing, distributing, marketing and selling products and services. Private companies can't be run out of the public affairs department because key functional teams across the company need to be involved, especially to do it at scale. However, some operating structures and processes can't easily be leveraged. Thus, lower expected rates of return and lack of clarity about the relative importance of commercial and social objectives can also cause strategic and operational misalignment.
- c) **Capability gaps:** Companies' capabilities drive their performance. The extent to which capabilities need to be adapted or built from scratch is a critical success factor of every company. "These can include the ability to implement any of the solutions outlined in the annex, from managing informal distribution channels to providing inventory on credit to processing hundreds of thousands of small transactions". It is often possible to acquire the capabilities necessary to bring a company to its success.

### 2.2 External barriers to business

External barriers to business are mainly represented by the threats companies face when entering a new market and which are described in Michael Porter's five forces model. These five barriers are the same threats a company faces when it wants to grow [10]:

- a) **Threat of new entrants:** Profitable markets that yield high returns will attract new companies. This results in many new entrants which eventually will decrease profitability for all companies in the industry. Unless the entry of new companies can be blocked by incumbents, an abnormal profit rate will trend towards zero.
- b) **Threat of substitutes:** The existence of products outside of the realm of the common product boundaries increases the propensity of customers to switch to alternatives.
- c) **Bargaining power of buyers:** The bargaining power of customers is also described as the market of outputs. Customers have the ability to put a company under pressure which also affects the customer's sensitivity to price changes. Companies can take measures to reduce buyer power, such as implementing a loyalty program.
- d) **Bargaining power of suppliers:** The bargaining power of suppliers is also described as the market of inputs. Suppliers of raw materials, components, labor and services to a company can be a source of power over another company when there are few substitutes.
- e) **Industry rivalry:** For most industries, the intensity of competitive rivalry is the major determinant of the competitiveness of the industry.

Any of these threats could affect the growth of a small, as well as a large company [11]. Besides external barriers described in Michael Porter's five forces model, other external barriers may come from low demand of the product or service from customers, difficult access to raw materials, late payments of bills by business customers, government interference, public procurement rules and regulations-related difficulties in exporting the product to foreign countries [12]. External barriers most frequently occur in export [13]. The most effective tools to overcome such barriers are knowledge and information [14]. Another possibility is to overcome external barriers by funding from the public sector which is linked not only to the non-profit sector but even to the private sector [15].

### 3. Methodology

The aim of the paper is to identify major barriers in selected industry of the Slovak business environment. The main motive for the selection of the paper's topic were researches conducted by various authors who have dealt

with barriers to business in the conditions of Latin America [16 and 17]. To fulfill the aim of the paper, it was necessary to understand terms related to barriers to business. We are inclined to a primary classification which identifies internal barriers and external barriers to business.

Another step is performing a primary research, based on the methods of querying, analysis, comparison and selection. Respondents were represented by companies operating in the advertising industry. To evaluate statistical indicators, the formula for small core files and unknown distribution, critical value, dispersion, variability of core group of respondents ( $p = 0.5$ ) and maximum allowable margin of errors  $\langle \pm 10\%; \pm 2\% \rangle$  were used [18].

Respondents were contacted via e-mail and telephone. The questionnaire, focused on identifying barriers in the Slovak business environment from the view of advertising agencies operating in the Zilina region, consisted of 20 questions. The results of questions related to the aim of this paper are to be presented in the form of text and graphs.

#### 4. Results

The Slovak advertising industry consists of two components – media agencies dealing with buying shares of media market and communications market. Communications market covers all agencies focusing on creative advertising, PR agencies and production companies. The industry experienced the biggest boom in the late nineties. It grew annually by 20.00% between years 2005 and 2008. In 2009, as a result of the economic crisis, a turnover in the market fell by 35.00% [19].

Business environment in Slovakia is not facing serious problems threatening the existence of companies because the situation is slowly improving due to the new laws and support programs created by the Slovak Government. Although, there are certainly various barriers and the aim of our primary research was to find them. The main source of primary research was the questionnaire focused on identifying barriers in the Slovak business environment from the view of advertising agencies operating in the Zilina region. The questionnaire was composed of questions mapping the possible barriers that companies come into contact with when performing their activities. 50 companies were approached, nevertheless only 34 of them answered. This represents a 68.00% rate of return. 38.20% of companies have existed less than five years, 32.40% of companies have existed from six to ten years and remaining 29.40% of companies have existed more than 10 years.

When speaking about the impact of the company's position on its results, 55.90% of companies are unaware of any impact, 38.20% of companies perceive a positive impact and 5.90% experience a negative impact. It is striking that 70.60% of companies have faced some strong barriers to

business and only 29.40% of companies have never faced such barriers.

We assumed that the incomprehensibility of laws represents a major barrier to business in Slovakia. This assumption was partially confirmed, since 58.30% of companies said that the incomprehensibility of laws has a partial impact on their business, 12.50% of companies perceive significant impact and 29.20% do not perceive any impact. This is related to the intensity of the monitoring of changes in the law. Some companies monitor such changes on a monthly basis, other companies monitor such changes on a quarterly, half-yearly or annual basis. There are even companies that do not monitor such changes at all. Summary of replies is depicted in Fig. 1.

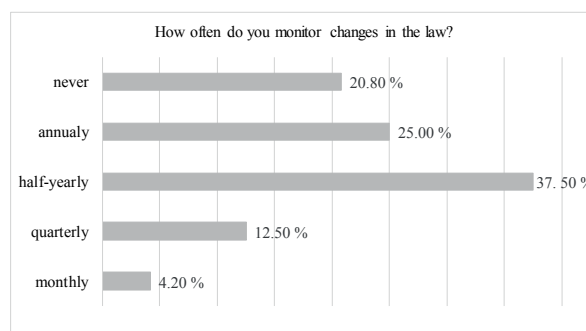

Fig. 1 The intensity of the monitoring of changes in the law (Source: Own research)

We also assumed that the competitive pressure is another major barrier to business. However, it is interesting that some companies (20.80%) do not monitor activities of their competitors at all. Fortunately, 29.20% of companies monitor the activities of their competitors in detail and 50.00% of companies monitor the activities of their competitors only partially.

Finally, we come to the most important question in which respondents were supposed to identify major barriers to business. Respondents had the possibility to mark several options. Summary of replies is depicted in Fig. 2.

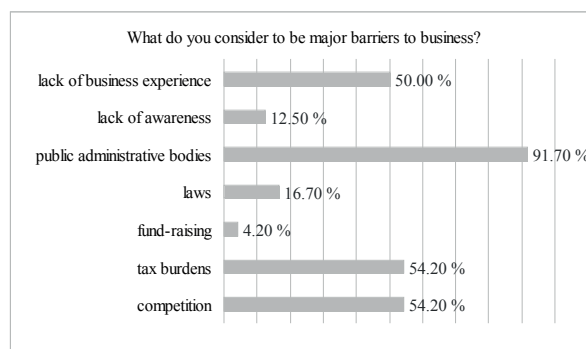

Fig. 2 Major barriers to business identified by respondents (Source: Own research)

According to respondents, the main barrier to business is represented by the work of public administrative bodies which affects activities of companies because they have to face this barrier every day. This is a problem that company can't influence in any way because the work of public administrative bodies determines general rules which have to be followed.

## 5. Conclusion

When it comes to addressing internal and external barriers companies face, it catalyzes greater and more open dialogue on solutions companies can use to tackle them. However, the bigger barrier, the more difficult solution is required. Even though, the most important is to be able to identify the barriers. The aim of the paper was to identify major barriers in selected industry of the Slovak business environment. To fulfill the aim of the paper, a primary research, based on the methods of querying, analysis, comparison and selection, was conducted. The questionnaire, focused on identifying barriers in the Slovak business environment from the view of advertising agencies operating in the Zilina region, consisted of 20 questions. Respondents were contacted via e-mail and telephone. The questionnaire was composed of questions mapping the possible barriers that companies come into contact with when performing their activities. 50 companies were approached, nevertheless only 34 of them answered. We can conclude that respondents can be divided into three groups:

- a) companies whose business is affected by the barriers,
- b) companies whose business is partly influenced by barriers,
- c) companies whose business is not affected by the barriers.

We assumed that the incomprehensibility of laws represents a major barrier to business in Slovakia. This assumption was partially confirmed, since 58.30% of companies said that the incomprehensibility of laws has a partial impact on their business, 12.50% of companies perceive significant impact and 29.20% do not perceive any impact. We also assumed that the competitive pressure is another major barrier to business. However, it is interesting that 20.80% of companies do not monitor activities of their competitors at all. Fortunately, 29.20% of companies monitor the activities of their competitors in detail and 50.00% of companies monitor the activities of their competitors only partially. Finally, these are major barriers to business identified by respondents:

- a) public administrative bodies (91.70 %),
- b) competition (54.20 %),
- c) tax burdens (54.20 %),
- d) lack of business experience (50.00 %),
- e) laws (16.70 %),
- f) lack of awareness (12.50 %),
- g) fund-raising (4.20 %).

The paper provided a very general look at what barriers came to the attention of companies. Since the size of the sample has limited the possibility of generalization of the results, this leads us to future research aimed at the larger sample of companies. Also, it would be interesting to conduct similar research in another industry and to compare the results with our results gained in an advertising industry.

## References

- [1] VRABLOVA, L., GREGOR, M.: Company in Crisis. *Communications - Scientific Letters of the University of Zilina*, No. 4, 2011, 78-81. ISSN 1335-4205.
- [2] HITTMAR, S., JANKAL, R.: *Strategic Management of Networks. Management of Network Organizations: Theoretical Problems and the Dilemmas in Practice*, 2015, 5-21, Cham : Springer International Publishing.
- [3] VARTIAK, L.: CSR Reporting of Companies on a Global Scale. *Procedia Economics and Finance*, 39, 2016, 176-183. ISSN 2212-5671.
- [4] VARTIAK, L.: *Importance of Reputation in the Assessment of Corporate Social Responsibility*, Proc. of CBU intern. Conference Innovations in Science and Education, 2015, 82-88, Prague. ISBN 978-80-88042-00-6.
- [5] JANKALOVA, M.: *Business Calculations* (in Slovak), Zilinska univerzita, 2014.
- [6] STOFKOVA, J. et al.: *Business Management*, Bratislava : DOLIS, 2015.
- [7] EUCHNER, J.: Declining Barriers to Innovation, *Research-Technology Management*, 58(6), 2015, 10-11.
- [8] BCTA (2010). BARRIERS TO PROGRESS: *A Review of Challenges and Solutions to Inclusive Business Growth*. Retrieved August 17, 2016, from <http://www.businesscalltoaction.org/wp-content/uploads/2010/11/Barriers-to-Inclusive-Business-Final-11.12.2010-LR.pdf>.
- [9] WBCSD: *Scaling up Inclusive Business: Solutions to Overcome Internal Barriers*, Geneve : WBCSD, 2013.
- [10] PORTER, M. E.: The Five Competitive Forces that Shape Strategy, *Harvard Business Review*, January 2008, 86-104.
- [11] HISRICH, R. D., PETERS, M. P.: *Entrepreneurship*, Sydney : McGraw-Hill/Irwin, 2002.

- [12] BARTLETT, W., BUKVIC, V.: Barriers to SME Growth in Slovenia, *MOST : Economic Policy in Transitional Economies*, 11(2), 2001, 177-195.
- [13] KAHIYA, E. T., EAN, D. L.: Export Barriers and Business Confidence: A Quasi-Longitudinal Examination. *Asia Pacific J. of Marketing and Logistics*, 27(2), 2015, 294-323.
- [14] MATOS, P., MENESES, R.: *The Importance of Knowledge and Information to Overtake Export Barriers: A Case Study of Portuguese SME. Innovation, Entrepreneurship and Sustainable Value Chain in a Dynamic Environment*, Proc. of 8<sup>th</sup> Annual conference of the EuroMed Academy of Business, 1515-1528, 2015, Verona : University of Verona.
- [15] RENTKOVA, K., MAJERCAKOVA, D.: Financing and Cooperation between the Public Administration and Non-Profit Sector in the Slovak Republic. *ACRN J. of Finance and Risk Perspectives*, 2(2), 2013, 60-68.
- [16] CAHEN, F. R. et al.: Managerial Perceptions of Barriers to Internationalization: An Examination of Brazil's New Technology-based Firms. *J. of Business Research*, 69(6), 2016, 1973-1979.
- [17] CARDOZA, G. et al.: Barriers and Public Policies Affecting the International Expansion of Latin American SMEs: Evidence from Brazil, Colombia and Peru. *J. of Business Research*, 69(6), 2016, 2030-2039.
- [18] FORET, M., STAVKOVA, J.: *Marketing Research: How to Know our Customers* (in Czech), Prague : Grada Publishing, 2003.
- [19] Neulogy 2013: *Report on the State and Potential of the Creative Industry in Slovakia* (in Slovak), Bratislava : Neulogy, 2013.

Jozef Gasparik - Vladimir Luptak - Petr V. Kurenkov - Pavol Mesko\*

## METHODOLOGY FOR ASSESSING TRANSPORT CONNECTIONS ON THE INTEGRATED TRANSPORT NETWORK

*The periodic line transport expresses an integrated periodic timetable, which is also a periodical liner form of surveillance and network interconnection. An important factor is to reduce the interchange times in selected areas, or transport hubs. The aim is to minimise the total transit time of a passenger from point A to point B. The cornerstone of transport services is to provide travel opportunities by creating links and connections. Often, after the introduction of the new timetable and a discussion of whether it is better or worse, each approach is evaluated in a subjective manner. The authors solved some problems of rail passenger quality services. At present, there is no methodology for assessing train timetables from the transportation point of view as a whole. We evaluate specific trains and connections in the stations only, but not the quality of the connection from point A to point B.*

**Keywords:** Relation, Lill's model, integrated transport network, quality.

### 1. Dependence of integrated transport network

A transport network is a set of hubs and connecting road sections. On the transport network are moving, entering and then outputting physical objects (e.g. passenger trains, wagon load, etc.). A mathematical model of the network may have a final graph of a finite number of vertices, and a mixed graph with oriented or non-oriented edges, graph  $G = (V, E, c, d)$  comprising of a set  $V$  of vertices (e.g. train stations, stops, tariff points and so on), a set  $E$  of edges (e.g. interstationary sections),  $c(h)$  a permeable capacity of the edge or edge part,  $(h)$  is the length of the edge.

In transport networks, as in other systems, the distinguishing level is important. The timetables for rail passenger services are sufficient just when one station is in the graph, represented by a single vertex (from network sense, this is called a node). But for the management needs of rail passenger services, each station is designed for the boarding and disembarking of passengers (flow change on the edge) that are seen as a particular peak [1].

An extension of a conventional line, periodic transport is an integrated periodic timetable (IPTT). In this system are except of periodical repeating of the linear form also monitored the network interconnection and minimising of interchanges times in selected points (transport hubs) where are crossing

the individual lines operated for a given period. The aim of this network effect is to minimise the total transferring time of the passenger from point A to point B. This is the most difficult form of operation for transport services, because it demands precision planning and has requirements in terms of boundary conditions. The essential requirements are imposed on the size of the edge periodic time between two nodes, where mutual changes are expected. Substituting the time of the edge can be implemented by a combination of measures related to the infrastructure, setting of the corresponding vehicles, and finally, the connections offered (timetable) [2].

The basis of IPTT consists of the periodic timetable of the superior railway network. Optimal transfer options are given when all trains meet at the same time at a transfer node (usually it is a transfer train station). In this time period, it is necessary to operate the transfer point by additional means of transport. Thus it is possible, with minimum cost, to transport the passengers from all areas to the transfer stations. In an analogous treatment are passenger transported in the opposite direction in a relatively short time. This creates a scheme of connections in the transfer node, the so-called 'transfer spider' [3].

Any such transfer spider has a timeline that represents the period of time for the transfer in the node. This timeline

\* <sup>1</sup>Jozef Gasparik, <sup>2</sup>Vladimir Luptak, <sup>3</sup>Petr V. Kurenkov, <sup>1</sup>Pavol Mesko

<sup>1</sup>University of Zilina, Faculty of Operation and Economics of Transport and Communications, University of Zilina, Slovakia

<sup>2</sup>Moscow State Transport University, Institute of Management and Information Technology, Moscow, Russia

E-mail: jozef.gasparik@fpedas.uniza.sk

determines the edge time. The situation depicted in transfer spiders is regularly repeated after every time period.

The connections meet from opposite directions on the line (for trains crossing) because of timetable symmetry at intervals equal to half the time period. Thus, if the transfer node is situated in the time span of an integer multiple of half of the period, the meeting of lines from the opposite direction is just in these nodes.

The time interval between the symmetrical axes of transfer spiders of two adjacent transfer nodes is called edge time. For periods of one hour, the edge times are 30, 60, 90 minutes. In the systematised transport network described above, one point to any other point can be done without any major time loss from waiting for connections. This possibility should be given for round-trips back to the starting point, so that the axis of symmetry ends in the transfer spider. Therefore, the time required for the round-trip is equal to an integral multiple of the period. These laws show that the timetable conditions of this kind require contingent journey times between nodes; there is no need to prefer the maximum line speed, because all depends on a system travel time.

**2. Description procurement systems in use today**

With the continuity of the traffic flow, it is necessary to choose two places with the coordinates  $x_1$  and  $x_2$  on the route of the transport flow. The size of the flowing masses (e.g. number of trains), located at time  $t$ , respectively,  $t + \Delta t$ , between these points is:

$$\int_{x_1}^{x_2} h(x, t) dx, \text{ resp. } \int_{x_1}^{x_2} h(x, t + \Delta t) dx \tag{1}$$

and thus, their difference, indicating a change of this size is:

$$D = \int_{x_1}^{x_2} (h(x, t + \Delta t) - h(x, t)) dx \tag{2}$$

This difference of  $D$  can be expressed in other ways, such as the difference between during the interval  $(t, t + \Delta t)$  flowing through point  $x_1$  and  $x_2$ , and flowing off through point  $x_2$ :

$$\begin{aligned} D &= \int_t^{t+\Delta t} q(x_1, \tau) d\tau - \int_t^{t+\Delta t} q(x_2, \tau) d\tau = \\ &= \int_t^{t+\Delta t} [q(x_1, \tau) - q(x_2, \tau)] d\tau \end{aligned} \tag{3}$$

From the merit of definite integrals results that at each fixed  $\tau$ , or  $x$  is equally:

$$\begin{aligned} q(x_1, \tau) - q(x_2, \tau) &= - \int_{x_1}^{x_2} \left[ \frac{\partial q(x, \tau)}{\partial x} \right] dx, \\ h(x, t + \Delta t) - h(x, t) &= \int_t^{t+\Delta t} \left[ \frac{\partial h(x, \tau)}{\partial \tau} \right] d\tau \end{aligned} \tag{4}$$

and thus the difference  $D$  can be expressed by a double integral, changing the order of integration:

$$\begin{aligned} D &= \int_{x_1}^{x_2} \left[ \int_t^{t+\Delta t} \left( \frac{\partial h(x, \tau)}{\partial \tau} \right) d\tau \right] dx = \\ &= \int_t^{t+\Delta t} \left[ \int_{x_1}^{x_2} \left( \frac{\partial q(x, \tau)}{\partial x} \right) dx \right] d\tau = \\ &= \int_{x_1}^{x_2} \left[ \int_t^{t+\Delta t} \left( - \frac{\partial q(x, \tau)}{\partial x} \right) d\tau \right] dx \end{aligned} \tag{5}$$

Because the first and third integrals have the same limits, and those limits were chosen arbitrarily, also from the integrals equality result integrated functions, and therefore, at any point  $x$  and any time  $\tau$  must be true:

$$\begin{aligned} \frac{\partial h(x, \tau)}{\partial \tau} = - \frac{\partial q(x, \tau)}{\partial x} &\iff \frac{\partial h(x, \tau)}{\partial \tau} + \\ &+ \frac{\partial q(x, \tau)}{\partial x} = 0 \end{aligned} \tag{6}$$

This is one of the most important relationships in traffic flow theory. We call it the continuity equation of traffic flow. In accordance with the physical analogy as well transport flow conditions for the rail transportation conditions, the basic state quantities are characterised, which are necessary for the quality evaluation of connections in the transport network. Generally, there is a need to interpret them for the indicators of relevant quality values. Generally, the state quantities are [1]:

- speed
- intensity = number of units of flow, passing a given point per unit of time
- density = number of flow units per unit distance routes in a given place and a given time
- wave speed = speed of point movement with a given density.

**3. Defining quality indicators for the links evaluation on the transport network**

The proposed methodology aims to comprehensively cover the possibility of achieving any pair of tariff points by passenger trains on a selected rail network in order to assess the quality of the travel opportunities in the area using selected indicators.

The methodology is based on the evaluation of defined criteria for connectivity between the selected tariff points on the network. Based on the methodology, we evaluate a particular connection. It is necessary to determine whether the connection is evaluated during the workday or the weekend. It is also possible to evaluate a selected workday, Saturday, or Sunday. Consequently, we evaluate the summarising indicators for services in terms of particular relations within the examined networks [4].

For assessing the connectivity and quality of connections in an examined relation (session), we identify the following factors, some of which are introduced in literature [2 - 6]:

- *Number of connections*  $N_s$  during the reporting day, direct connections as well connections with changes (transfers).
- *Average waiting time of passenger*  $W_f$ . This is the time that the passenger has to wait for a connection to a point of departure, or possibly a transfer point. It is defined as half of the time between the departures of two successive connections.
- *Distance route of relation*  $L_r$ . This is the travel distance by vehicles creating the connection. This criterion is important to calculate transportation speed and the rate of achievement.
- *Type and number of trains* creating the connection. This factor reflects the quality of transport services on the connection.
- *Transportation time*  $T_p$ . Time between the departure from the boarding station on the route and disembarking the train at the destination railway station (tariff point).
- *Number of transfers (changing means of transport)*  $N_p$ . This is the absolute number of changes of transport vehicles (trains) before reaching the target station.
- *Transfer time*  $T_w$ . This is the total time that passengers spend waiting for connections at the transfer station (by changing means of transport) when using a particular connection.
- *Achieving time*  $T_D$ . This is the time from embarking when the travel trip begins, to the arrival of the train at the destination railway station. It is calculated as the sum of the average waiting time and transportation time.
- *Transportation speed*  $V_p$ . This is given as a proportion of the distance travelled and time of transfer.
- *Achieving start-stop speed*  $V_D$ . This is given as a proportion of the length of the relation and achieving time [5].

Transportation speed and achieving speed are important evaluation criteria for the quality of a particular connection relation. They are convenient indicators for comparing public transport link connections with individual transport [6].

After processing the connections, an evaluation of a single session is necessary to evaluate the relation between tariff points on the network. For each session averages of criteria for all connections are calculated: the number of transfers, transfer time, the speed of transfer rate and speed of achievement [7]. For an example see Table 1.

### 3.1. Comparative analysis of selected indicators for timetable assessment

Table 2 are processed the start-stop achieving speeds on selected connections and evaluated the average per relation from Bratislava hl.st to selected tariff points. Studied were timetable periods 2013, 2014, 2015 and 2016.

On the ground of the average values we can conclude that the examined start-stop achieving speeds have downward trend in the three periods, but the current timetable 2016 has contrary increasing trend. It shows that the timetable 2016 is in terms of start-stop achieving speeds better quality in general. It is an objective indicator for timetable quality evaluation.

Sample of connection assessment on the X - Y relation (workday)

Table 1

| Connection Number       | Station X departure [hh:min] | Station Y arrival [hh:min] | Average waiting time $W_f$ [h] | Connection distance $L_r$ [km] | Transport means | Transport time $T_p$ [h] | Number of transfers $N_p$ | Total changing time $T_w$ [min] | Start-stop achieving time $T_D$ [h] | Travel speed $V_p$ [km.h <sup>-1</sup> ] | Start-stop achieving speed $V_D$ [km.h <sup>-1</sup> ] |
|-------------------------|------------------------------|----------------------------|--------------------------------|--------------------------------|-----------------|--------------------------|---------------------------|---------------------------------|-------------------------------------|--|--|
| 1                       | 6:53                         | 9:36                       | 6.25                           | 158                            | R,              | 2.72                     | 0                         | 0.00                            | 8.97                                | 58.16                                    | 17.62  |
| 2                       | 8:03                         | 12:20                      | 0.58                           | 192                            | R,Os,Os         | 4.28                     | 2                         | 0.28                            | 4.87                                | 44.82                                    | 39.45  |
| 3                       | 10:53                        | 13:44                      | 1.42                           | 158                            | R               | 2.85                     | 0                         | 0.00                            | 4.27                                | 55.44                                    | 37.03  |
| n                       | 18:53                        | 21:35                      | 1.42                           | 158                            | R               | 2.70                     | 0                         | 0.00                            | 4.12                                | 58.52                                    | 38.38  |
| Average per connection: |                              |                            |                                |                                |                 |                          | 0.88                      | 0.22                            | 4.96                                | 53.04                                    | 38.49  |

Source: Authors

Comparison of more timetable periods assessment according to the average start-stop achieving speed indicator

Table 2

| From Bratislava hl.st. to station | Average start-stop achieving speed for connection $V_D$ [km.h <sup>-1</sup> ] | From Bratislava hl.st. to station | Average start-stop achieving speed for connection $V_D$ [km.h <sup>-1</sup> ] | From Bratislava hl.st. to station | Average start-stop achieving speed for connection $V_D$ [km.h <sup>-1</sup> ] | From Bratislava hl.st. to station | Average start-stop achieving speed for connection $V_D$ [km.h <sup>-1</sup> ] |
|-----------------------------------|---|-----------------------------------|---|-----------------------------------|---|-----------------------------------|---|
| Timetable 2013                    |   | Timetable 2014                    |   | Timetable 2015                    |   | Timetable 2016                    |   |
| Kosice                            | 66.62   | Kosice                            | 66.62   | Turcianske Teplice                | 67.17   | Kosice                            | 65.09   |
| Presov                            | 65.33   | Poprad                            | 59.50   | Trencin                           | 65.21   | Trencin                           | 64.43   |
| Poprad-Tatry                      | 64.48   | Cierna n. Tisou                   | 59.07   | Kuty                              | 61.47   | Nove Zamky                        | 62.55   |
| Zilina                            | 62.92   | Tat. Lomnica                      | 58.79   | Poprad                            | 60.01   | Poprad                            | 62.27   |
| Trencin                           | 62.39   | Nove Zamky                        | 58.25   | Nove Zamky                        | 57.03   | Presov                            | 61.65   |
| Trebisov                          | 60.41   | Trencin                           | 57.25   | Tat. Lomnica                      | 56.86   | Zilina                            | 61.35   |
| Cierna n. Tisou                   | 59.07   | Zilina                            | 57.19   | Sturovo                           | 56.66   | Trebisov                          | 60.46   |
| Nova Zamky                        | 59.01   | Turcianske Teplice                | 57.14   | Piestany                          | 55.17   | Humenne                           | 59.86   |
| Gelnica                           | 58.94   | Sturovo                           | 56.66   | Sabinov                           | 54.28   | Kuty                              | 58.31   |
| Tat. Lomica                       | 58.79   | Strbske Pleso                     | 54.24   | Martin                            | 54.08   | Cierna n. Tisou                   | 57.29   |
| .                                 | .   | .                                 | .   | .                                 | .   | .                                 | .   |
| .                                 | .   | .                                 | .   | .                                 | .   | .                                 | .   |
| .                                 | .   | .                                 | .   | .                                 | .   | .                                 | .   |
| Kremnica                          | 36.78   | Banska Stiavnica                  | 32.81   | Dunajska Streda                   | 31.74   | Prievidza                         | 38.18   |
| Zeliezovce                        | 36.50   | Vranov n. Toplou                  | 32.49   | Kremnica                          | 30.97   | Skalite                           | 37.72   |
| Myjava                            | 36.16   | Dunajska Streda                   | 31.67   | Utekac                            | 30.61   | Kremnica                          | 37.57   |
| Makov                             | 34.74   | Kremnica                          | 30.97   | Vranov n. Toplou                  | 29.77   | Skalica                           | 36.08   |
| Dunajska Streda                   | 33.86   | Utekac                            | 30.53   | Bardejov                          | 27.80   | Banska Stiavnica                  | 34.49   |
| Sahy                              | 33.31   | Bardejov                          | 27.61   | Stara Lubovna                     | 26.03   | Dunajska Streda                   | 32.05   |
| Banska Stiavnica                  | 28.84   | Záhorska Ves                      | 25.33   | Makov                             | 25.55   | Sahy                              | 31.61   |
| Zahorska Ves                      | 23.72   | Makov                             | 25.18   | Zahorska Ves                      | 25.33   | Zahorska Ves                      | 25.21   |
| Zlate Moravce                     | 18.60   | Zlate Moravce                     | 19.58   | Zlate Moravce                     | 18.56   | Zlate Moravce                     | 18.91   |
| <b>Average per connection</b>     | <b>47.34</b>  | <b>Average per connection</b>     | <b>43.26</b>  | <b>Average per connection</b>     | <b>43.22</b>  | <b>Average per connection</b>     | <b>47.86</b>  |

Source: Authors

#### 4. An adequate number of network connections using the Lill's model

In transport planning, it is possible to encounter situations where it is necessary to determine quantified estimates of the size of traffic flows between two points over a selected period of time (intensity, density), for situations where it is not possible to carry out a direct survey of transport demand. It is also necessary, in some cases, to determine the impact of

individual measures of the transport department of the size of its traffic share. This applies particularly to the number of changes in transport, the number of connections or transport distances [8]. For these reasons, empirical models are used for determining of the passenger flow characteristics (Lill's model), which is closely related to the number of available network connection [2, 9 and 10].

#### 4.1. Lill's model

Lill's model is used to determine the approximate number of connections between two settlement units, where the distance is generally considered between centres. Lill's model has the following form [2]:

$$j_{1,2} = \frac{A_1 \cdot A_2}{d^n} \cdot K \quad (7)$$

where:

- $j_{1,2}$  number of trips between the two cities for a specified time period
- $A_{1,2}$  population (in thousands) at specific locations
- $d$  distance places
- $K$  index (is depending on the largeness and binding of locations 1 and 2),
- $N$  value approaching the value of 2.

#### 4.2. Expansion possibilities of the gravity model

Due to the large variation of optimal values in Lill's gravity model and of actual values, it is essential to modify the current formula for optimal number of connections between two points. This expanded formula shall give more real values as well to be an objective evaluator of quality of transport relations and connections [7 and 10].

The current formula Lill's gravity model considers only the population of origin and destination traffic and point to their remoteness, the objectivity of the evaluation is not satisfactory. The proposed extension of the model under consideration, with a population in transit traffic points within those programs, as well as distance of railway station (stop) from the centre of individual towns and villages of surveyed session. Transit traffic point in this case means any train station, which is considered the loading and disembarking of passengers. These factors may also significantly affect the number of passengers carried and thus the number of optimal connection of the session [11].

The extended model will reflect the fact that the population of individual settlements is directly proportional to the number of transported passengers, but the distance between settlements and access to railway stations (stops) is inversely proportional to this number. This modified model will consider an optimal number of connections in passenger rail transport only, generally in one direction (for both directions the value will be multiplied by two). The proposed formula for the extended Lill's gravity model is [2 and 12]:

$$j_{1,2} = \frac{\frac{A_1 \cdot A_2}{d_1 \cdot d_2 \cdot l_1^2} + \frac{A_2 \cdot A_3}{d_2 \cdot d_3 \cdot l_2^2} + \dots + \frac{A_{n-1} \cdot A_n}{d_{n-1} \cdot d_n \cdot l_{n-1}^2}}{n} \quad (8)$$

where:

- $j_{1,2}$  optimal number of trips between the two settlements for a specified time period
- $A_1$  population (current in thousands) at first, starting, point (settlement)
- $A_2$  population (current in thousands) at first, transit, point (settlement)
- $A_n$  population (current in thousands) at terminal point (settlement)
- $d_1$  availability of railway station / stop (the distance from the settlement centre) of starting point [km]
- $d_2$  availability of railway station / stop (the distance from the settlement centre) of first transit point [km]
- $d_n$  availability of railway station / stop (the distance from the settlement centre) of terminal point [km]
- $l_1$  distance between the starting and the first transit point [km]
- $l_2$  distance between the first and the second transit point [km]
- $l_{n-1}$  distance between the last transit and the terminal point [km]
- $n$  number of points (stops) within a transport relation, including start and terminal points
- $K$  modified original gravity model index.

The formula represents in detail the dependence of quantitative indicator of the quality of transported passengers and the indicators of population, transport distance and accessibility of stations (stops). From its structure it shows that the number of summands in the numerator of the main fraction is dependent on the number of train stops at different stations and stops in the relation. The modified original gravity model index is determined by expert estimation and generally takes the value of 5 - 25. It depends on the nature, distance, or even the number of individual settlements on a given relation. In case of major number of stops and the relatively short distances between the transport points the index will acquire lower values. In case of fewer stops and longer distances between these points the index will acquire higher values [7 and 13].

#### 5. Conclusion

The proposed methodology is used for the possibility of achieving any pair of tariff points in a selected railway network comprehensively. It not only offers an evaluation of the connectivity of a particular relation, but also objectively assesses the availability of connections between two selected tariff points, based on quality indicators such as average number of transfers, average waiting time, average transportation speed, and average achieving speed. This

enables us to evaluate the quality of the travel opportunities in this area by using selected indicators. Subsequently, using multiple criteria analysis allows us to evaluate the degree of customer satisfaction with selected quality attributes based on their importance. Ultimately, it is possible to examine the statistical dependence of the number of transported rail passengers by examining the quality connection of the network [11, 13 and 14].

The proposal will contribute to the creation of a competitive transport system that efficiently uses system resources. Such is the plan of a Single European Transport Area within the purview of the white paper, 'Roadmap to a Single European Transport Area-Towards a competitive and resource efficient transport system'. This aims for the attainment of an efficient and integrated system of mobility. The importance of the quality, accessibility, and reliability of transport services in the coming years may be even more important [15 and 16].

Another aim of the article is to outline the methodology for determining the required number of transport links between settlement units in passenger traffic. In terms of passengers, it must assess the availability of opportunities to travel between selected points on the transport network. Offering transportation from point A to point B in principle affects transportation time, the number of connections and the number of travel opportunities. On connections and the transfer, connections are thus influenced by a number of factors in transport planning, which is the basis for the empirical model [13].

#### Acknowledgements

The paper is supported by the VEGA Agency under Project 1/0095/16, 'Assessment of the quality of connections on the transport network as a tool to enhance the competitiveness of public passenger transport system'.

#### References

- [1] CERNA, A., CERNY, J.: *Managerial Decisions about Transport Systems* (in Czech), University of Pardubice, 2014, 230 p., ISBN 978-80-7395-849-7.
- [2] DRDLA, P.: *Passenger Traffic Regional and National Importance* (in Czech), University of Pardubice, No. 1., 2014, 412 p., ISBN 978-80-7395-787-2
- [3] LUPTAK, V., GABOROVA, V., ZITRICKY, V.: The Application of Empirical Models in Transport Planning in the Slovak Republic (in Slovak), *Zeleznicna doprava a logistika*, 2015, p. 10-13. ISSN 1336-7943. Online at: [https://fpedas.utc.sk/zdal/images/zdal/archiv/zdal\\_2015\\_02.pdf](https://fpedas.utc.sk/zdal/images/zdal/archiv/zdal_2015_02.pdf)
- [4] POLIAK, M., KRIZANOVA, A., SEMANOVA, S., GAJANOVA, L.: The Influence of Contract form Choice of the Transport Services Ensuring on Performance Contracting Entity Requirement. *Transport Problems = Problemy Transportu: Intern. Scientific J.*, vol. 9, No. 4, 2014, pp. 153-161, ISSN 1896-0596
- [5] STOPKA, O., SIMKOVA, I., KONECNY, V.: The Quality of Service in the Public Transport and Shipping Industry. 2015. *Nase More*, University of Dubrovnik, vol. 62, Special Issue, 126-130. ISSN 0469-6255
- [6] GASPARIK, J.; SIROKY, J.; PECENY, L.; HALAS, M.: Methodology for Assessing the Quality of Rail Connections on the Network. *Communications - Scientific Letters of the University of Zilina*, vol. 16, No. 2, 2014, 25-30. ISSN 1335-4205
- [7] ZITRICKY, V., GASPARIK, J., PECENY, L.: The Methodology of Rating Quality Standards in the Regional Passenger Transport. *Transport Problems = Problemy Transportu: International Scientific J.*, sp. Edition, vol. 10, 2015, pp. 59-72
- [8] KENDRA, M.; MASEK, J.; PONICKY, J. et al: *Proposal of Methodology for Calculating the Quantity of Validation Machines in Railway Transport*, Conference: 6<sup>th</sup> Transport Research Arena (TRA), Warsaw: Book Series: Transportation Research vol. 14, 1977-1986.
- [9] ALDIAN, A., TAYLOR, M. A. P.: Fuzzy Multicriteria Analysis for Inter-city Travel Demand Modelling. *J.of the Eastern Asia Society for Transportation Studies*, vol. 5, 2003, 1294-1307
- [10] HADAS, Y., CEDER, A.: Public Transit Network Connectivity: Spatial-based Performance Indicators. *Transportation Research Record: J. of the Transportation Research Board*, 2143, 2010, 1-8
- [11] YEDLA, S., SHRESTHA, M.: *Multi-criteria Approach for the Selection of Alternative Options for Environmentally Sustainable Transport System in Delhi*. *Transportation Research Part A*, vol. 37, No. 8, 2003, 717-729, ISSN: 0965-8564
- [12] LUPTAK, V., GASPARIK, J., PECENY, L.: *Methodology for Assessing the Quality of Rail Connections on the Network*. Proc. of conference Transcom 2015, University of Zilina, 81-86, ISBN 978-80-554-1043-2
- [13] MISHRA, S., WELCH, T.F., JHA, M.K.: Performance Indicators for Public Transit Connectivity in Multi-Modal Transportation Networks. *Transportation Research Part A: Policy and Practice*, 46, 2012, 1066-1085

- [14] SCHULZ, A.: Integrated Periodic Timetable in Germany (in German). *Eisenbahn-Revue International*, No. 9-10, 1994, 277-284
- [15] STOPKA, O., PONICKY, J., CHOVANCOVA, M., ZITRICKY, V.: Draft Method for Determining the Number of Checking Devices Utilized within the Regional Passenger Transport. *Nase More: J. of Marine Science*, vol. 63, No. 3, 200-203. ISSN 0469-6255
- [16] HORNÁK, M., PSENKA, T., KRIZAN, F.: The Competitiveness of the Long-distance Public Transportation System in Slovakia. *Moravian Geographical Reports*, 21, 4, 2013, 64-75, ISSN 1210-8812.

Carlos Lopez-Escolano - Angel Pueyo Campos - Sergio Valdivielso Pardos - Eva Nedeliakova  
Vladimira Stefancova\*

## INCORPORATING BICYCLES INTO URBAN MOBILITY: AN OPPORTUNITY FOR SUSTAINABLE DEVELOPMENT

*This paper addresses the new role of bicycles as a mode of sustainable urban transport in several cities, after decades of being seen as a minor means of transport. Socio-economic changes over the last few decades and demands from a much more aware public are facilitating the re-incorporation of bicycles into areas not only where they are normally found, such as northern European countries, but also into less usual places, like Spain. In this context, this research aims to assess how much access the public has to various cycling infrastructures, such as bicycle lanes or bike-sharing stations. It also delves into how urban planning and management have made it possible to bicycles in the urban scene, also the main challenges and difficulties to be overcome to make full integration. The analysis includes drawing up themed maps to assess accessibility in the city of Zaragoza in Spain, one of the examples of a change in urban mobility towards a more sustainable system.*

**Keywords:** Sustainable transport, bicycle, cycling infrastructures, accessibility.

### 1. Introduction

In Europe, bicycles used to be the usual form of transport in several cities in countries such as Holland, Belgium, Denmark, Germany, France and northern Italy; however, after the Second World War, there was a major shift in urban and metropolitan mobility towards motor vehicles [1], which became the norm for urban transport in western cities and countries [2]. The rise in the price of fuel caused by the oil crisis in the 1970s, together with a period of response and social change, made bicycles resurface as a real alternative transport in certain situations [3]. Thus, after several years in decline [4], cycling went from being a leisure activity or minor form of transport to an element of growing importance in urban journeys [1].

This socio-cultural transformation, focused on a demand for healthier, more environmentally sustainable lifestyles, started in northern European countries, especially the cities that are now a benchmark worldwide for sustainable urban mobility, such as Copenhagen [5 and 6], Amsterdam and Utrecht [7 and 8]. This trend shift, which was put forward as part of the solution to increasing urban and environmental problems (traffic jams, air and noise pollution, loss of quality of life, etc.), could also be found elsewhere in Europe and North America [9]. Deserving mention is the radical MAB

-*Le Monde a Bicyclette*- movement in Montreal in 1975, and in medium-sized cities in Europe, such as Geneva and Toulouse, which in the 1980s made managing the use of bicycles into a policy objective [1].

More recently, European organizations have encouraged a new urban, environmentally sustainable mobility model [10] which is forcing public administrations to support initiatives catering for the latest provisions and policies on transport [5 and 11]. This has led cities in Europe to institute measures to adopt sustainable urban mobility models like the bicycle, coming late to countries, such as those of the Mediterranean, little used to cycling as a normal form of transport [12]. Nevertheless, from the beginning of the 21st century, bicycles have been very actively included into the urban mobility of several cities in southern Europe [13].

Most research on the subject has centred on planning sustainable mobility and its urban infrastructure [13 - 16 and 17], on its effect on urban areas and mobility [18 - 20], and on identifying attitudes and conflicts brought about by incorporating bicycles into cities [12, 21, 22 and 23].

Therefore, this paper aims to focus on less researched aspects, such as assessing the bicycle as a means of transport to promote sustainable urban development and allow more balanced access to facilities and services [9]. The city of Zaragoza in Spain was chosen to carry out the case study as

\* <sup>1</sup>Carlos Lopez-Escolano, <sup>1</sup>Angel Pueyo Campos, <sup>1</sup>Sergio Valdivielso Pardos, <sup>2</sup>Eva Nedeliakova, <sup>2</sup>Vladimira Stefancova

<sup>1</sup>University of Zaragoza, The Environmental Sciences Institute of Aragon, Department of Geography and Territorial Planning, Spain

<sup>2</sup>University of Zilina, Faculty of Operation and Economics of Transport and Communications, Department of Railway Transport, Slovakia  
E-mail: cle@unizar.es

it has recently implemented a number of policies and actions to promote use of the bicycle as a normal mode of transport.

## 2. Incorporating bicycle transport into cities in Spain

Unlike other countries in this context, support from institutions and businesses for implementing bicycles as a means of transport in Spanish cities has come about only recently [12]. Special attention has been paid to building specific infrastructures, such as cycle lanes and bike-sharing schemes [13]. Consequently, bicycles still do not represent a significant percentage of transport modes in Spanish cities, although their importance has been growing lately. Thus, in 2011, 7.4% of the population said that they cycled to their destinations daily or almost daily, and 40.3% did so frequently. These values rose in 2015 to 10% and 49.6% respectively [24]. Besides investment in infrastructure and encouraging this mobility mode, other factors have influenced this increase, such as the public deeming the bicycle to be a normal mode of transport, whereas this was not the case before [12], further strengthened by falling living standards due to the effects of the economic crisis [25].

In this context, there have been several successes in integrating bicycles as another means of transport within mobility plans in cities in Spain. Among these are Barcelona, Valencia, Seville, Victoria-Gasteiz and Zaragoza [13 and 24].

A profile of bicycle use in Spanish cities (Table 1) shows that, by 2014, it was a normal means for the public to move around cities like Valencia, Vitoria-Gasteiz, Zaragoza and Seville, where over 35% of the people used it at least once a week, while Madrid and Bilbao still did not reach more than 20%. This situation can be associated with the degree of users' satisfaction with infrastructure, traffic conditions, distance,

terrain, climate, the chance to interchange with another mode of transport, and the availability of cycle parking.

In this respect, planning and implementing cycling infrastructure has been one of the actions with greatest impact in achieving some success in incorporating bicycles into sustainable urban mobility. Over the last few years in Spain, there have been two main developments towards this - building cycle lanes and starting up bike-sharing schemes. The new cycle lanes have provided cycle journeys with quality, speed and safety, while also avoiding disputes with other road users. As for bike-sharing schemes, according to Fishman's paper [26], these have become fairly important in Spain, since it has been widely implemented in several cities (Fig. 1). Thus, Barcelona stands out as the pioneer of incorporating this scheme in Spain in 2012 [27], and is placed among the top positions worldwide, as there are 3.7 public bicycles available for each 1,000 inhabitants. The most successful example of integrating cycling into urban mobility in Spain is Seville,

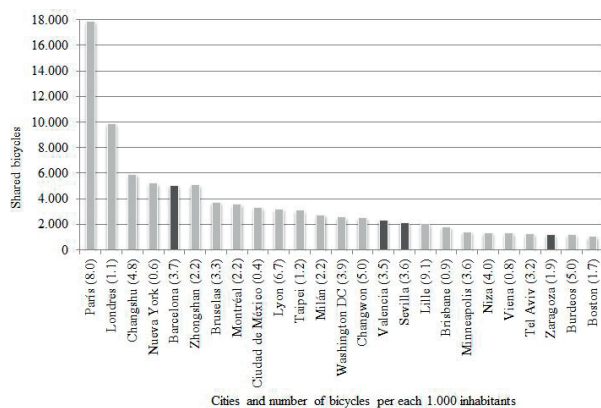

Fig. 1 Number of total shared bicycles available and number of bicycles per inhabitant in 2014 [26 - 27 and 28]

Use of bicycle and degree of satisfaction by city in 2014

Table 1

| City                   | Use once a week or more (% of population) | Global satisfaction degree (0-100) |
|------------------------|---|------------------------------------|
| Valencia               | 47  | 65                                 |
| Vitoria-Gasteiz        | 46  | 71                                 |
| Zaragoza               | 45  | 64                                 |
| Palma de Mallorca      | 37  | 62                                 |
| Sevilla                | 35  | 78                                 |
| Málaga                 | 28  | 56                                 |
| Donostia-San Sebastián | 25  | 72                                 |
| Barcelona              | 24  | 59                                 |
| Madrid                 | 19  | 36                                 |
| Bilbao                 | 17  | 50                                 |

Source: [24]

where 5% of all urban journeys between 2006 and 2011 were made by bicycle [13]. Seville's scheme was carried out with a relatively small investment in infrastructure, thanks to proper design and management of a cycle lane network that has facilitated the use of bicycles [13]. Identifying features in the cycling mobility model in Seville are continuity, connectivity, homogeneity, visibility, comfort and speedy implementation of the project [13].

### 3. The case of Zaragoza

As with other Spanish cities, Zaragoza, with a population of 665,000 has experienced the introduction and growth of cycle journeys over the last few years. The interest of municipal officials in promoting a more sustainable mobility without the combustion engine led to drafting the Sustainable Mobility Plan in 2006 [29], including sustainable modes of transport like trams and bicycles. In 2008, to coincide with the city holding the International Exhibition, a number of actions were started on urban infrastructures through an investment plan which included designing a road network giving pedestrian and cycling access to the exhibition ground [12 and 19].

At the same time, an increase in the use of bicycles was quickly seen on the city's streets. In 2013, 7.4% of the population used bicycles as a normal way of getting to work, double the number recorded in 2007 [30]. In this respect, the main reasons for the model's success were: extending the cycle lane network, starting up the *Bizi* bike-sharing scheme consisting of 130 stations and 1,300 bikes, and municipal regulations allowing bicycles to travel on a good many streets and pavements [12].

### 4. Analysis to assess accessibility by bicycle

One of the main objectives of the Intermodal Transport Plan of 2006 [29] was to make this scheme work by improving the share of pedestrian and cycling modes and obtaining appropriate access to urban facilities and services. In order to be able to assess the effects of bicycles on public access and urban facilities, the cycle lanes, *Bizi* stations, the city's main structural facilities (administrative, health, university, sports, shopping centres, and tourism and culture), public transport stops (tram and local trains), and the population for each block with information updated to 2015, were added to a Geographical Information System.

Later, a spatial analysis method calculated the public's access from the centroid of each block of buildings and *Bizi* stations to the cycle lane network, in distances of 150, 300 and 500 metres. The distances were also used to measure access to *Bizi* stations for the public structural facilities. Shorter distances were used for access to *Bizi* stations from trams and local trains: 50, 100 and 150 metres -which are thought to generate new routes and increase potential distances of transport in the city using a combined model that includes bicycles-. However, this method of analysis does not include privately owned bicycles, so the opportunities for using intermodal options of travel that include cycling are much higher.

First, cycle lanes were analysed for accessibility for the public and from *Bizi* stations (Fig. 2). The results show that the public has very high access: 59.91% of the population is less than 150 m. away from a cycle lane, 84.26% at less than 300 m., and 93.89% at less than 500 m. The number of *Bizi* stations near the cycle lane network is equally high: 57.69% are

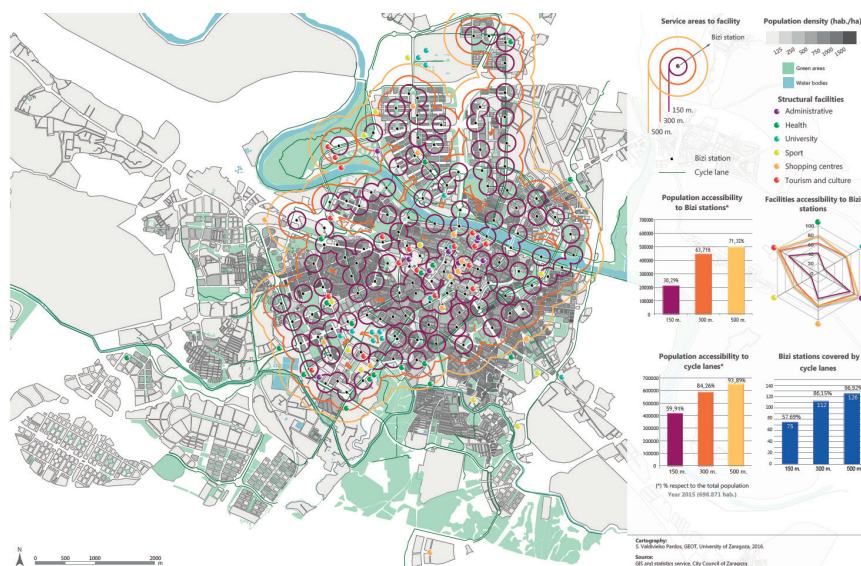

Fig. 2 Accessibility from structural facilities [12]

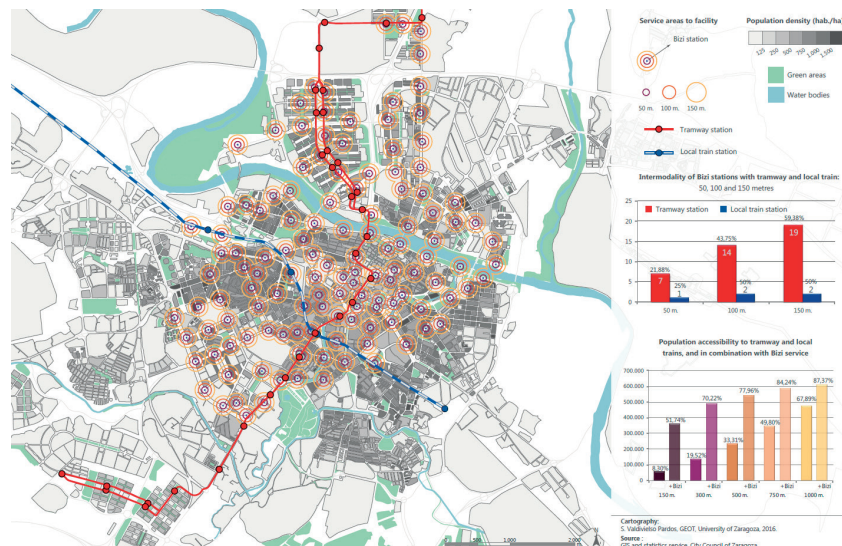

Fig. 3 Potential intermodality of the Bizi scheme with trams and local trains [12]

less than 150 m. away, 86.15% at less than 300 m. and 96.92% at less than 500 m.

Second, the proximity of Bizi bike-share stations to the public and urban facilities was analysed (Fig. 2). 50.25% of the population was less than 150 m. away from a Bizi station, rising to 68.33% at less than 300 m. and 74.79% at less than 500 m. Accessibility from the main urban facilities to Bizi stations showed that most of the stations in the scheme were adequately located. The best results were obtained for stations at tourism and cultural sites and at facilities, with almost 100% of these located at less than 300 metres from a Bizi station. There was worse access from shopping centres, health facilities and university sites, with only 60% to 70% of stations found at less than 300 m. away. On the other hand, sports centres were the least accessible, with just over 50% standing at less than 300 m. away.

Lastly, the potential intermodality was analysed for bicycles with other means of transport where bicycle access is possible (Fig. 3), such as trams and local trains.

These results show that most of the public and the structural facilities have good access to cycling infrastructure [31].

## 5. Conclusions

In a “post-carbon” society” [32] that is increasingly demanding new choices and profound change in transport models, bicycles have proved to be an effective alternative for urban mobility in several contexts. Moreover, it is an option that generates numerous benefits for society, the economy, the environment and human health [33]. In practice, such a social change would lead to a different urban scene and

behaviour after decades of dominance by private vehicles taking priority [12], since the incorporation of bicycles substantially alters the distribution of transport modes, and encourages a transformation of public spaces to promote compatibility with private vehicles, taxis, buses, trams bicycles and pedestrians [18].

Spain still has to learn from the policies carried out in other European countries - Holland, Denmark and Germany [34] - and copy their measures to encourage a more sustainable urban mobility. To this end, it is essential for cycling to spread and become completely normal as a means of urban transport, which would necessitate a “cycling culture” to be created [5 and 35]. In the case of Zaragoza, urban planning has been the key to effective inclusion of bicycles by updating tools, such as the Intermodal Transport Plan of 2006. Pending challenges include implementing a more integrated and denser network of cycle lanes, and extending the capacity and cover of the Bizi scheme, which would improve levels of accessibility [36]. The cycle lane network must be extended by building new routes to form a mesh network and provide bicycles with their own space to increase their safety and use [2]. Lastly, it should be emphasised that regulatory processes involving the public, actors and public administrations must also be strengthened to reach agreement on boosting this mode of transport within an integral project for mobility and a sustainable city [12].

## Acknowledgements

This article has been carried out within the framework of the projects “PLOTÉG: Herramientas cartograficas para una gobernanza inteligente en las ciudades digitales: Analisis territorial de las condiciones de vida”, and “PLOYEG2:

Indicadores multiescalares y herramientas cartograficas para el analisis de la vulnerabilidad socioeconomica y residencial en areas urbanas: aplicacion al caso de Zaragoza”, funded by Ministry of Economy, R&D Spanish program Grant

agreement no. CSO2013-46863-C3-3-R and CSO2016-74888-C4-3-R, and supported by the Aragon Regional Government and the European Social Fund.

## References

- [1] RIVIERE, M.: *Socio-histoire du velo dans l'espace urbain. D'une ecologie politique a une economie mediatique...*, Toulouse : Geneve : Saragosse, Doctoral Thesis, 2009, Universite Toulouse II.
- [2] DAVID, A., SOSEDOVA, J., PUTZ, L-M., JOLIE, N., KAVRAN, Z.: European Automated Container Terminals, *Communications - Scientific Letters of the University of Zilina*, vol. 16, No 2, 2014, 41-45, ISSN 1335-4205.6.
- [3] ALDRED, R.: *The Role of Advocacy and Activism*, Parkin, John (Ed.), *Cycling and Sustainability*, Emerald : Bingley, 2012, 83-108, ISBN 978-1-78052-298-2.
- [4] AGERVIG CARSTENSEN, T.; EBERT, A. K.: *Cycling Cultures in Northern Europe: From 'Golden Age' to 'Renaissance'*, Parkin, J. (Ed.), *Cycling and Sustainability*, Emerald : Bingley, 2012, 23-58, ISBN 978-1-78052-298-2.
- [5] GOSSLING, S.: Urban Transport Transitions: Copenhagen, City of Cyclists, *J. of Transport Geography*, 33, 2013, 196-206, ISSN 09666923.
- [6] SNIZEK, B., ALEXANDER, T., NIELSEN, S., SKOV-PETERSEN, H.: Mapping Bicyclists' Experiences in Copenhagen, *J. of Transport Geography*, 30, 2013, 227-233, ISSN 09666923.
- [7] BERTOLINI, L., LE CLERQ, F.: *Urban Development without More Mobility by Car? Lessons from Amsterdam, a Multimodal Urban Region*, *Environment and Planning A*, 35:4, 2003, 575-589, ISSN 0308518X.
- [8] HARMS, L., BERTOLINI, L., TE BROMMELSTROET, M.: Performance of Municipal Cycling Policies in Medium-Sized Cities in the Netherlands since 2000, *Transport Reviews*, 36:1, 2016, 134-162, ISSN 01441647.
- [9] NEDELIAKOVA, E.: KEGA 026ZU-4/2015 *Innovative Approaches to the System of Teaching Management in the Study Program Railway Transport with a Focus on Application of the Dynamic Quality Models in Railway Transport*.
- [10] EUROPEAN COMMISSION: White Paper. Roadmap to a Single European Transport Area - Towards a Competitive and Resource Efficient Transport System. European Commission, Luxembourg, 2011.
- [11] HENSON, R; ESSEX, S.: Conception, Organisation et Evaluation de Deseaux de Transport Locaux Durables, *Revue internationale des sciences sociales*, 2003/2, 176, 2003, 243-260, ISSN 0304-3037.
- [12] PUEYO CAMPOS, A.; LOPEZ ESCOLANO, C.; DIESTE HERNANDEZ, J.: L'evolution de Saragosse vers la mobilite durable : le velo comme mode de transport urbain. Consensus, paralysie et conflits d'un modele en effervescence, *Sud-Ouest Europeen*, 40, 2016, 101-114, ISSN 12764930.
- [13] MARQUES, R., HERNANDEZ-HERRADOR, V., CALVO-SALAZAR, M.; GARCIA-CEBRIAN, J. A.: How Infrastructure can Promote Cycling in Cities: Lessons from Seville, *Research on Transportation Economics*, 53, 2015, 31-44, ISSN 07398859.
- [14] BERTOLINI, L., LE CLERQ, F., KAPOEN, L.: Sustainable accessibility: A conceptual framework to integrate transport and land use plan-making. Two test-applications in the Netherlands and a reflection on the way forward, *Transport Policy*, 12:3, 2005, 207-220, ISSN 0967070X.
- [15] HEINEN, E., VAN WEE, B., MAAT, K.: Commuting by Bicycle: An Overview of the Literature, *Transport Reviews*, 30:1, 2010, 59-96, ISSN 01441647.
- [16] PUCHER, J.; DILL, J.; HANDY, S.: Infrastructure, Programs, and Policies to Increase Bicycling: An International Review, *Preventive Medicine*, 50, 2010, 106-125, ISSN 00917435.
- [17] SATO, H., MIWA, T., MORIKAWA, T.: A Study on Use and Location of Community Cycle Stations, *Research in Transportation Economics*, 53, 2015, 13-19, ISSN 07398859.
- [18] ALDRED, R.: Editorial. Cycling and Society, *J. of Transport Geography*, 30, 2013a, 180-182, ISSN 09666923.
- [19] ARRANZ-LOPEZ, A., SORIA-LARA, J. A., LOPEZ-ESCOLANO, C.; PUEYO-CAMPOS, A.: Retail Mobility Environments: A Methodological Framework for Integrating Retail Activity and Non-motorised Accessibility in Zaragoza (in Spain), *J. of Transport Geography*, 57, 2016, 241-254, in press.
- [20] BUEHLER, R., DILL, J.: Bikeway Networks: A Review of Effects on Cycling, *Transport Reviews*, 36:1, 2015, 9-27, ISSN 01441647.

- [21] JONES, P.: Performing the City: A Body and a Bicycle take on Birmingham, *Social and Cultural Geography*, 6:6, 2005, 813-830, ISSN 14649365.
- [22] ALDRED, R.: Incompetent or Too Competent? Negotiating Everyday Cycling Identities in a Motor Dominated Society, *Mobilities*, 8:2, 2013b, 252-271, ISSN 17450101.
- [23] PASSAFARO, P., RIMANO, A., PICCINI, M. P., METASTASIO, R., GAMBARDELLA, V., GULLACE, G., LETTIERI, C.: The Bicycle and the City: Desires and Emotions Versus Attitudes, Habits and Norms, *J. of Environmental Psychology*, 38, 2014, 76-83, ISSN 02724944.
- [24] RED DE CIUDADES POR LA BICICLETA.: *Barometro Anual de la Bicicleta en Espana*, 2015.
- [25] PUEYO CAMPOS, A., HERNAANDEZ NAVARRO, M.L.: L'Espagne face a la Grande Recession depuis 2008, *Mappemonde*, 111, 2013, 1-20, ISSN 17697298.
- [26] FISHMAN, E.: Bikeshare: A Review of Recent Literature, *Transport Reviews*, 36, 2016, 92-113, ISSN 01441647.
- [27] SEGUI PONS, J. M., MATEU LLADO, J., RUIZ PEREZ, M., MARTINEZ REYNES, M. R.: Los sistemas de bicicleta publica y la movilidad urbana sostenible. Un analisis en la ciudad de Palma (Mallorca, Islas Baleares), *Boletin de la Asociacion de Geografos Espanoles*, 71, 2016, 227-245, ISSN 0212-9426.
- [28] O'BRIEN, O.: *Bicycle Sharing Systems - Global Trends in Size* (Working Papers Series). London : UCL Centre for Advanced Spatial Analysis, 2014. ISSN 1467-1298.
- [29] AYUNTAMIENTO DE ZARAGOZA: *Plan Intermodal de Transportes. Plan de Movilidad Sostenible de Zaragoza*. Ayto. de Zaragoza : Zaragoza, 2006.
- [30] UGT-ARAGON, AYTO. DE ZARAGOZA: *Reduccion de emisiones de CO<sup>2</sup> en los desplazamientos a los centros de trabajo*. Ayto. de Zaragoza : Zaragoza, 2013.
- [31] LUSKOVA, M., HUDAKOVA, M., BUGANOVA, M.: *Importance of Risk Management in Enterprise Quality Planning in Slovakia*, ICEEM 2<sup>nd</sup> intern. conference on economic, education and management. Hong Kong : Education Society. 2012, ISBN 978-988-19750-3-4.
- [32] THEYS, J.: Les villes «post-carbone» moteurs de l'economie verte de demain? *ESKA, Annales des Mines - Responsabilite et environnement*, 61, 2011, 128-133, ISSN 1268-4783.
- [33] WOODCOCK, D., BANISTER, D., EDWARDS, P., PRENTICE, A. M., ROBERTS, I.: *Energy and Transport*, *Lancet*, 370, 2007, 1078-1088, ISSN 01406736.
- [34] PUCHER, J., BUEHLER, R.: Making Cycling Irresistible: Lessons from the Netherlands, Denmark and Germany, *Transport Reviews*, 28, 2008, 495-528, ISSN 01441647.
- [35] JENSEN, A.: Controlling Mobility, Performing Borderwork: Cycle Mobility in Copenhagen and the Multiplication of Boundaries, *J. of Transport Geography*, 30, 2013, 220-226, ISSN 09666923.
- [36] SULGAN, M., SOSEDOVA, J.: Rationalization of Internal Transport Operation in the Intermodal Transport Terminal, *Communications - Scientific Letters of the University of Zilina*, vol. 18, No 2, 2016, 5-10, ISSN 1335-4205.

Jiri Cejka - Mykola Guchenko\*

## OPTIMIZATION OF DISTRIBUTION ROUTES BY WAY OF THE MULTILEVEL APPROACH TO THE TRAVELING SALESMAN PROBLEM

The article „Optimization of Distribution Routes by way of the Multilevel Approach to the Traveling Salesman Problem“ is concerned with the optimization of the distribution routes. The goal is to use the obtained data to try to optimize and propose alternatives of the circular routes for the company Vltavotynske lahudky. For implementing this task, the principle of the module for solving the transport-related tasks was used. This module was developed by the Department of the Operational and System Analysis of the Czech University of Life Sciences in Prague.

**Keywords:** Optimization, transport, logistics, traveling salesman problem, nearest neighbor method, Hungarian method.

### 1. Introduction

The Vltavotynske lahudky company operates a total of seven lines, with one driver and one vehicle allocated to each of them. For the company’s needs, two lines on which the number of kilometres needs to be minimized were selected. The first chosen line is the line No. 2 (Tyn - Trebon - Nove Hradky - Tyn). The second line is line No. 5 which is in Table 2. (Tyn - Trhove Sviny - Tyn) [1 - 6].

Table 1 describes the current route of line No. 2 which contains the loading point (Tyn nad Vltavou) and other seven unloading points which the driver has to serve. After the last stop the driver returns back to the initial point (Tyn nad Vltavou) [7 - 9]. The route is indicated in Fig. 1.

Current line No. 2

Table 1

| Stop location       | Order | Distance from the previous stop (km) | Cumulated distance (km) |
|---------------------|-------|--------------------------------------|-------------------------|
| Tyn nad Vltavou     | 1     | 0                                    | 0                       |
| Lisov 456           | 2     | 43.5                                 | 43.5                    |
| Trebon 992          | 3     | 12.6                                 | 56.1                    |
| Suchdol nad Luznici | 4     | 19.3                                 | 75.4                    |
| Ceske Velenice      | 5     | 17.5                                 | 92.9                    |
| Nove Hradky 336     | 6     | 15.3                                 | 108.2                   |
| Horni Stropnice 47  | 7     | 7.5                                  | 115.7                   |
| Borovany 476        | 8     | 22.2                                 | 137.9                   |
| Tyn nad Vltavou     | 9     | 49.9                                 | 187.8                   |

Source: Author

\* <sup>1</sup>Jiri Cejka, <sup>2</sup>Mykola Guchenko

<sup>1</sup>Department of Transport and Logistics, Institute of Technology and Businesses in Ceske Budejovice, Czech Republic

<sup>2</sup>Kremenchuk Mykhailo Ostrogradskyi National University, Ukraine

E-mail: cejka@mail.vstecb.cz

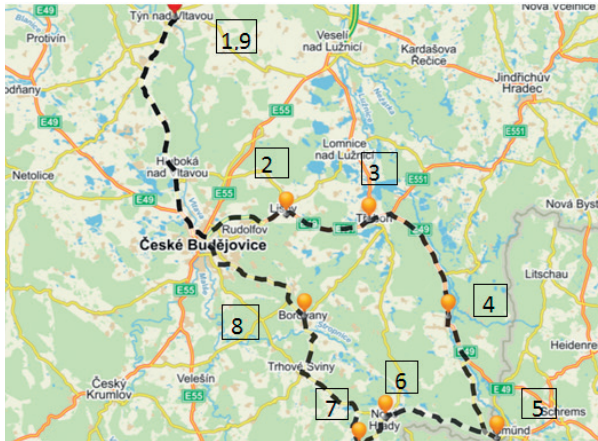

Source: Author  
Fig. 1 Line No. 2

The entire route is 187.8km long. The distribution is carried out every Wednesday using the lorry Iveco Turbo Daily 35C15. The car departs at 4:45 a.m. and finishes at about 9:15 a.m.

Table 2 describes the current distribution situation on line No. 5. Line No. 5 starts at Tyn nad Vltavou where the driver loads the required amount of products and then he drives to the consequent places listed in the table. After serving all the required places the vehicle returns back to the initial position [10]. The route is indicated in Fig. 2.

The total length of line No. 5 amounts to 251.4km. The driver departs at 4:45 a.m. and finishes at 9:15 a.m.

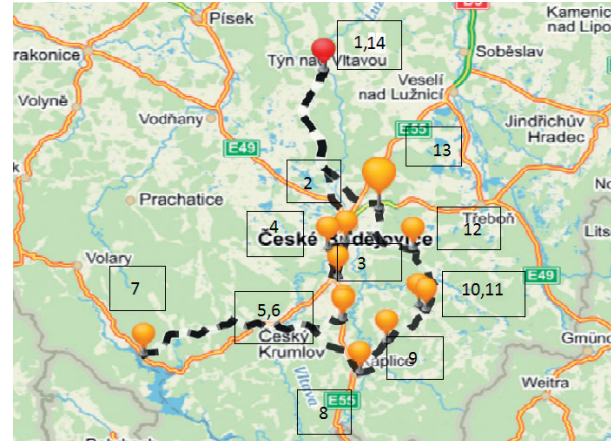

Source: Author  
Fig. 2 Line No. 5

## 2. Optimization of Distribution Routes by way of the Multilevel Approach to the Traveling Salesman Problem

In this type of problems, there is a single supplier (consumer) who distributes (loads) the goods to the places of consumption. After visiting the last place the means of transport returns back to the initial point. Every place is visited only once. The goal of the solution is to set the order of the visited places so that the total number of kilometers or the total costs (CZK) of transportation were minimum. The Hungarian method was applied to solve the traveling salesman problem. The source and target objects are identical here

Current line No. 5

Table 2

| Stop location        | Order | Distance from the previous stop (km) | Cumulated distance (km) |
|----------------------|-------|--------------------------------------|-------------------------|
| Tyn nad Vltavou      | 1     | 0                                    | 0                       |
| Roznov 207           | 2     | 35.9                                 | 35.9                    |
| Kamenny Ujezd 497    | 3     | 8.7                                  | 44.6                    |
| Homole u C. B.       | 4     | 8.2                                  | 52.8                    |
| Třeřa Velesin        | 5     | 15                                   | 67.8                    |
| Velesin 1            | 6     | 0.1                                  | 67.9                    |
| Horní Plana          | 7     | 41.9                                 | 109.8                   |
| Kaplice              | 8     | 47.5                                 | 157.3                   |
| Výrobní Besednice    | 9     | 8.4                                  | 165.7                   |
| Zaruba- Trhové Sviny | 10    | 10.9                                 | 176.6                   |
| Trhové Sviny 185     | 11    | 0.9                                  | 177.5                   |
| Lednice 469          | 12    | 15                                   | 192.5                   |
| Adamov 166           | 13    | 20.1                                 | 212.6                   |
| Tyn nad Vltavou      | 14    | 38.8                                 | 251.4                   |

Source: Author

and represent the source and target points. The connection between the identical points is unacceptable; hence, there are prohibitive rates on the main diagonal of the matrix [10 - 14].

**2.1. Optimization of distribution routes - line No. 5**

First step: Identification of distances

The matrix of distances (Table 3) contains the current distances between the distribution points with a prohibitive rate on the main diagonal.

Second step: Line reduction

After finding the lowest value on each line, we will deduct this value from each value on the given line. The goal of the reduction is to obtain as many zeros (0) as possible in the matrix of rates. This step is solved in Table 4.

Third step: Column reduction

After finding the lowest value in each column, we will again deduct this value from each value in the given column. The values of the third step are contained in Table 5.

Matrix of distances of the line No. 2

Table 3

|   | 1    | 2    | 3    | 4    | 5    | 6    | 7    | 8    |
|---|------|------|------|------|------|------|------|------|
| 1 | x    | 43.5 | 44.4 | 62   | 79   | 68   | 68   | 49.9 |
| 2 | 43.5 | x    | 12.6 | 30.4 | 47.5 | 39.9 | 38.8 | 15.4 |
| 3 | 44.4 | 12.6 | x    | 19.3 | 36.4 | 28.5 | 34.1 | 17.6 |
| 4 | 62   | 30.4 | 19.3 | x    | 17.5 | 16.3 | 21.9 | 19.2 |
| 5 | 79   | 47.5 | 36.4 | 17.5 | x    | 15.3 | 22.2 | 33.9 |
| 6 | 68   | 39.9 | 28.5 | 16.3 | 15.3 | x    | 7.5  | 23.1 |
| 7 | 68   | 38.8 | 34.1 | 21.9 | 22.2 | 7.5  | x    | 22.2 |
| 8 | 49.9 | 15.4 | 17.6 | 19.2 | 33.9 | 23.1 | 22.2 | x    |

Source: Author

Line reduction

Table 4

|   | 1    | 2    | 3    | 4    | 5    | 6    | 7    | 8    |
|---|------|------|------|------|------|------|------|------|
| 1 | x    | 0    | 0.9  | 18.5 | 35.5 | 24.5 | 24.5 | 6.4  |
| 2 | 30.9 | x    | 0    | 17.8 | 34.9 | 27.3 | 26.2 | 2.8  |
| 3 | 31.8 | 0    | x    | 6.7  | 23.8 | 15.9 | 21.5 | 5    |
| 4 | 45.7 | 14.1 | 3    | x    | 1.2  | 0    | 5.6  | 2.9  |
| 5 | 63.7 | 32.2 | 21.1 | 2.2  | x    | 0    | 6.9  | 18.6 |
| 6 | 60.5 | 32.4 | 21   | 8.8  | 7.8  | x    | 0    | 15.6 |
| 7 | 60.5 | 31.3 | 26.6 | 14.4 | 14.7 | 0    | x    | 14.7 |
| 8 | 34.5 | 0    | 2.2  | 3.8  | 18.5 | 7.7  | 6.8  | x    |

Source: Author

Column reduction

Table 5

|   | 1    | 2    | 3    | 4    | 5    | 6    | 7    | 8    |
|---|------|------|------|------|------|------|------|------|
| 1 | x    | 0    | 0.9  | 16.3 | 34.3 | 24.5 | 24.5 | 3.6  |
| 2 | 0    | x    | 0    | 15.6 | 33.7 | 27.3 | 26.2 | 0    |
| 3 | 0.9  | 0    | x    | 4.5  | 22.6 | 15.9 | 21.5 | 2.2  |
| 4 | 14.8 | 14.1 | 3    | x    | 0    | 0    | 5.6  | 0.1  |
| 5 | 32.8 | 32.2 | 21.1 | 0    | x    | 0    | 6.9  | 15.8 |
| 6 | 29.6 | 32.4 | 21   | 6.6  | 6.6  | x    | 0    | 12.8 |
| 7 | 29.6 | 31.3 | 26.6 | 12.2 | 13.5 | 0    | x    | 11.9 |
| 8 | 3.6  | 0    | 2.2  | 1.6  | 17.3 | 7.7  | 6.8  | x    |

Source: Author

Fourth step: Selection of independent zeros and routing of the covering lines

In this step we will choose the „independent“ zeros, i.e. those zeros which are stand-alone on the line or in the column. We will draw a line horizontally and vertically to cover all zeros while drawing the minimum number of lines.

Fifth step: Selection of minimum and modification of the matrix

We will choose the lowest value from the remaining uncovered values. The not covered elements will be reduced by the „a“ elements. The elements which are covered will not change. The elements which are covered twice will increase by the „a“ value.

Sixth step: Final solution

If we do not find the optimum solution, we will repeat the line coverage process until we find the optimum solution. With respect to the relative labor intensity of the manual procedure, the Dumkosa module for solving the transport problem, developed by the Department of the Operational and System Analysis of the Czech University of Life Sciences in Prague, was used [12 - 14].

**Solution using the Dumkosa macro in Excel**

Identification of the final route is illustrated in Table 6.

After loading the Dumkosa macro, all distances were transformed into the MS Excel environment. As the program cannot work with the value „x“ it was replaced with the prohibitive rates, specifically 1000 to prevent the program from selecting this value. The final first solution according to the above Table 6 was not optimal as the cycle was closed prematurely (marked in yellow in the Table). Then the final data were modified - the prohibitive rates were allocated to prevent the allocation of the original rates. The whole procedure was repeated a few times until the optimum variant was achieved. A total of 4 iterations (marked in color) were carried out.

The individual steps of the route optimization gave rise, with respect to the minimization of the number of the traveled kilometres, to the combination of individual partial solutions. The following options of the circular routes were suggested based on the four iterations in the makro Dumkosa.

Table 7 contains 6 options of the route; the first route corresponds to the current model of distribution. From the other five selected options, only variant No. 6 is appropriate

Matrix of solution

Table 6

|   | 1    | 2    | 3    | 4    | 5    | 6    | 7    | 8    |
|---|------|------|------|------|------|------|------|------|
| 1 | x    | 43.5 | 44.4 | 62   | 79   | 68   | 68   | 49.9 |
| 2 | 43.5 | x    | 12.6 | 30.4 | 47.5 | 39.9 | 38.8 | 15.4 |
| 3 | 44.4 | 12.6 | x    | 19.3 | 36.4 | 28.5 | 34.1 | 17.6 |
| 4 | 62   | 30.4 | 19.3 | x    | 17.5 | 16.3 | 21.9 | 19.2 |
| 5 | 79   | 47.5 | 36.4 | 17.5 | x    | 15.3 | 22.2 | 33.9 |
| 6 | 68   | 39.9 | 28.5 | 16.3 | 15.3 | x    | 7.5  | 23.1 |
| 7 | 68   | 38.8 | 34.1 | 21.9 | 22.2 | 7.5  | x    | 22.2 |
| 8 | 49.9 | 15.4 | 17.6 | 19.2 | 33.9 | 23.1 | 22.2 | x    |

Source: Author

Legend:

|        |                                   |
|--------|-----------------------------------|
| Yellow | 1 <sup>st</sup> optimization step |
| Green  | 2 <sup>nd</sup> optimization step |
| Blue   | 3 <sup>rd</sup> optimization step |
| Red    | 4 <sup>th</sup> optimization step |

Options of the route

Table 7

|   |                   |  |          |
|---|-------------------|--|----------|
| 1 | 1-2-3-4-5-6-7-8-1 | 43.5+12.6+19.3+17.5+15.3+7.5+22.2+49.9=  | 187.8 km |
| 2 | 1-2-8-6-5-7-3-4-1 | 43.5+15.4+23.1+15.3+22.2+34.1+19.3+62=   | 234.9 km |
| 3 | 1-3-5-7-6-8-2-4-1 | 44.4+36.4+22.2+7.5+23.1+15.4+30.4+62=    | 241.4 km |
| 4 | 1-6-4-2-5-7-8-3-1 | 68+16.3+30.4+47.5+22.2+22.2+17.6+44.4=   | 268.6 km |
| 5 | 1-8-6-3-5-7-4-2-1 | 49.9+23.1+28.5+36.4+22.2+21.9+30.4+43.5= | 255.9 km |
| 6 | 1-2-8-7-6-5-4-3-1 | 43.5+15.4+22.2+7.5+15.3+17.5+19.3+44.4=  | 185.1 km |

Source: Author

Final route after applying the solution using the Hungarian method

Table 8

| Stop location       | Order | Distance from the previous stop | Cumulated distance |
|---------------------|-------|---------------------------------|--------------------|
| Tyn nad Vltavou     | 1     | 0                               | 0                  |
| Lisov 456           | 2     | 43.5                            | 43.5               |
| Borovany 476        | 3     | 15.4                            | 58.9               |
| Horni Stropnice 47  | 4     | 22.2                            | 81.1               |
| Nove Hradky 336     | 5     | 7.5                             | 88.6               |
| Ceske Velenice      | 6     | 15.3                            | 103.9              |
| Suchdol nad Luznici | 7     | 17.5                            | 121.4              |
| Trebon 992          | 8     | 19.3                            | 140.7              |
| Tyn nad Vltavou     | 9     | 44.4                            | 185.1              |

Source: Author

as it achieves shorter distances than the current route of the company. Final route after applying the solution using the Hungarian method is in Table 8 and Fig. 3 [12-14].

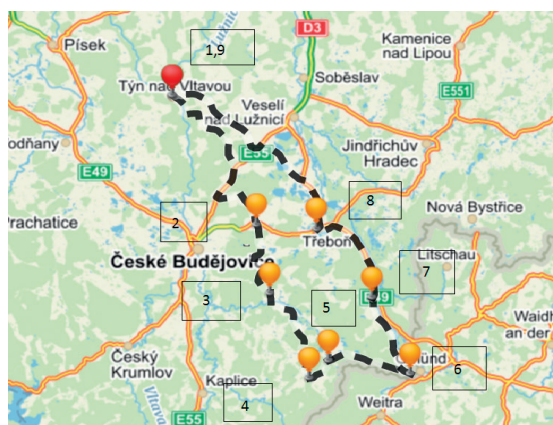

Source: Author

Fig. 3 Map of the optimized route of line No. 2

### 2.2. Optimization of distribution routes - line No. 5

The same procedure as for line No. 2 was also used for line No. 5. With respect to the similarity of the model, only the final solution is provided.

The first variant (Table 9) is the current route of distribution which the company follows. Except for variant 6, all variants represent the worse solution and they would

not be helpful in the route optimization. Route No. 6 is 244.8 kilometres long, which is optimal for making the modification of line No. 5 [12 - 14].

### 3. Conclusions

Despite finding the possibility of saving the number of kilometres using the above method, it can be concluded that the company uses the existing routes of lines No. 2 and 5 efficiently. The given solution is an alternative to other methods which deal with the similar problem. Although the final solution is not maximalist, it proves that the use of the alternative methods has its place in the current practice. For more information see Table 10.

The main purpose was to make the selected circular routes more effective in order to help to save the costs of transportation. To this end, the methods for optimization of the transport problems were used. The calculation of the traveling salesman problem was carried out in MS Excel using the Dumkosa module. The implementation of the problem has helped to find the more advantageous routes which, if introduced by the company, would help reduce the costs of the company. From the long-term perspective, they bring interesting savings [14].

Options of the route

Table 9

|   |                                 |  |          |
|---|---------------------------------|--|----------|
| 1 | 1-2-3-4-5-6-7-8-9-10-11-12-13-1 | 35.9+8.7+8.2+15+0.1+41.9+47.5+8.4+10.9+0.9+15+20.1+38.8=       | 251.4 km |
| 2 | 1-12-9-11-10-8-5-6-7-4-3-13-2-1 | 45.3+24.7+10.2+0.9+19.2+12.2+0.1+41.9+48.2+8.2+21.7+12.2+35.9= | 280.7 km |
| 3 | 1-3-5-6-7-4-12-9-8-10-11-13-2-1 | 42.1+9.6+0.1+41.9+48.2+18.5+24.7+8.4+19.2+0.9+28.9+12.2+35.9=  | 290.6 km |
| 4 | 1-4-5-3-2-12-9-7-6-8-10-11-13-1 | 37.7+15+9.6+8.7+15.2+24.7+50+41.9+12.1+19.2+0.9+28.9+38.8=     | 302.7 km |
| 5 | 1-4-2-3-5-7-8-6-10-9-11-12-13-1 | 37.7+6.2+8.7+9.6+41.8+47.5+12.1+16.2+10.9+10.2+15+20.1+38.8=   | 274.8 km |
| 6 | 1-13-2-3-7-5-6-8-9-11-10-12-4-1 | 38.8+12.2+8.7+42.9+41.8+0.1+12.1+8.4+10.2+0.9+12.5+18.5+37.7=  | 244.8 km |

Source: Author

Comparison of annual costs

Table 10

|                  |                               | Line No. 2 | Line No. 5   |
|------------------|-------------------------------|------------|--------------|
| Optimization     | Distance (km)                 | 9.625      | 58.752       |
|                  | Costs (CZK)<br>Internal rates | 32.640     | 149.817      |
| Original values  | Distance (km)                 | 9.766      | 60.336       |
|                  | Costs (CZK)<br>Internal rates | 33.120     | 153.857      |
| Total difference | Distance (km)                 | <b>141</b> | <b>1.584</b> |
|                  | Costs (CZK)                   | <b>480</b> | <b>4.040</b> |

Source: Author

## References

- [1] SULGAN, M., SOSEDOVA, J.: Procurement of Materials and Components for Manufacturing Activity. *Communications - Scientific Letters of the University of Zilina*, No. 2, 2014, 58-62, ISSN 1335-4205.
- [2] STOPKA, O., KAMPF, R., KOLAR, J., KUBASAKOVA, I., SAVAGE, C.: Draft Guidelines for the Allocation of Public Logistics Centres of Intern. Importance, *Communications - Scientific Letters of the University of Zilina*, vol. 16, No. 2, 2014, 14-19, ISSN 13354205.
- [3] TOMASIKOVA, M., BRUMERCIK, F., NIEOCZYM, A.: Vehicle Simulation Model Criterion, *Logi - Scientific J. on Transport and Logistics*, vol. 6, No. 1, 2015, 130-135, ISSN 1804-3216.
- [4] CERNA, L., ZITRICKY, V., MATEJKO, P.: Price Calculation in the International Railway Transport of Goods. *Logi - Scientific J. on Transport and Logistics*, vol. 4, No. 2, 2013, 11-27, ISSN 1804-3216.
- [5] LIZBETIN, J., VEJS, P., CAHA, Z., LIZBETINOVA, L., MICHALIK, P.: The Possibilities of Dynamic Shipment Weighing in Rail Freight Transport. *Communications - Scientific Letters of the University of Zilina*, vol. 18, No. 2, 2016, 113-117, ISSN 13354205.
- [6] SIMKOVA, I., KONECNY, V.: Key Performance Indicators in Logistics and Road Transport, *Logi - Scientific J. on Transport and Logistics*, vol. 5, No. 2, 2014, 87-96, ISSN 1804-3216.
- [7] RIEVAJ, V., STOPKA, O., VRABEL, J., MOKRICKOVA, L., SCHMIDT, C.: The Impact of Air Resistance on the Fuel Consumption in Real Conditions within the Transport Operation, *Communications - Scientific Letters of the University of Zilina*, No. 2, 2016, ISSN 1335-4205.
- [8] BARTUSKA, L., STOPKA, O., LIZBETIN, J.: *Methodology for Determining the Traffic Volumes on Urban Roads in the Czech Republic*, Transport Means Proc. of the Intern. Conference, 2015, 215-218, ISSN 2351-7034.
- [9] CEJKA, J., BARTUSKOVA, P., BARTUSKA, L.: *Application of Mathematical Methods in Transport and Logistic Area*, APLIMAT 2016 - 15<sup>th</sup> Conference on Applied Mathematics 2016, 225-235.
- [10] BARTUSKA, L., CEJKA, J., CAHA, Z.: The Application of Mathematical Methods to the Determination of Transport Flows, *J. Nase More, University of Dubrovnik 2016*, ISSN 04696255.
- [11] MATEJKO, P., CERNA, L., MAJERCAK, J.: *The Evaluation Methodology Logistic Processes, Involving Key Logistics Indicators International Scientific*, Conference Diagnostics Business and Controlling Logistics Slovak Republic, University of Zilina, 2012, ISSN 1336-7943.
- [12] ZITRICKY, V., GASPARIK, J., PECENY, L. The Methodology of Rating Quality Standards in the Regional Passenger Transport, *Transport Problems*, 10, 2015, 59-72. Cited 3 times. View at Publisher.
- [13] CEJKA, J.: *Transport Planning Realized Through the Optimization Methods*, Procedia Engineering, World Multidisciplinary Civil Engineering-Architecture-Urban Planning Symposium, WMCAUS 2016, Prague, vol. 161, 2016, 1187-1196, ISSN 1877-7058.
- [14] STOPKA, O., CEJKA, J., KAMPF, R., BARTUSKA, L.: *Draft of the Novel System of Public Bus Transport Lines in the Particular Territory*. Transport Means - Proc. of the 19<sup>th</sup> Intern. Scientific Conference on Transport Means, Kaunas : Kaunas University of Technology, 2015, 39-42, ISSN 1822-296X.

Andrea Galierikova - Jarmila Sosedova\*

## INTERMODAL TRANSPORTATION OF DANGEROUS GOODS

*The paper deals with intermodal transportation, broadly defined as a chain consisting of several transportation modes that are coordinated and interact in intermodal terminals to ensure door-to-door service. The goal of the article is to describe the road-sea intermodal flow, to define the responsibilities of each party of a transportation chain and to identify important issues and bottlenecks in the whole intermodal transportation. Recently, the demand for the transportation of dangerous goods has been rising. Transport of dangerous goods can have serious effects on the environment if an accident happens. The legal environment for each transport department, harmonisation of the rules and regulations for intermodal transportation and setting the responsibilities for every party of the transportation chain (such as forwarder, hauler, shipper and consignor) make the transports of dangerous goods more safe and efficient and can reduce risks and threats.*

**Keywords:** *Intermodal, transport, dangerous goods, agreement.*

### 1. Introduction

European Conference of Ministers of Transport (ECMT) defines intermodal transport as the movement of freight in one and the same loading unit or vehicle which uses successive, various modes of transport (road, rail, water) without any handling of goods themselves in changing modes [1].

Intermodality provides the economic performance of the transport chain by using different modes in the most productive manner. Many characteristics influence the intermodal transport chain:

- quantity and the nature of transported cargo,
- the sequence of transportation modes - the leading modes are lorries, rails and vessels (inland waterway or maritime). Air transportation is usually not used in the combination with other modes,
- places of origin and destination - the longer the transport distance, the more transportation modes are used,
- the value of the goods - high value shipments are usually transported by air, while low and intermediate shipments are usually transported by rail and inland waterways,
- frequency of shipments [1].

Intermodal transport combines the advantages of the individual modes of transport involved, namely the large capacity and relative speed of rail transport, the flexibility of road transport and the advantageous price and high capacity of water transport [2]. Another advantage is the provision of a service with one bill of lading (for cargo)

or one ticket (for passengers). This caused a revolution in organisation and information controlling. In present days, data are received, handled and distributed to the systems, which are essential to ensure the safe and cost-effective control of cargo and passenger movements. Electronic Data Interchange (EDI) is an evolving technology, which helps companies and government agencies to deal with the increasing global transport system [3].

Due to dangerous characteristics of the hazardous goods there are many risks in addition to those normally associated with general transport activities. According to the data of databases with information on dangerous transportations (US Department of Hazardous Material Transportation - Information system 4) it is clear that more than half of the total number of incidents occur during the activities at the transport hubs and nodes. In general, there exist different regulations governing dangerous transports by inland waterways, rail and roads, but in practice, the regulation of the whole intermodal transport of dangerous goods (DG) does not exist. The rules for safe international transport of dangerous goods (ADR, RID, AND, IMDG) ensure safety of the DG transports, reliability and functioning of the common transport market. Even though the regulations for every inland transport mode are harmonised (by the Directive 2008/68/EC of the European Parliament and of the Council), there is still area for improvement [4].

\* Andrea Galierikova, Jarmila Sosedova

Department of Water Transport, Faculty of Operation and Economics of Transport and Communications, University of Zilina, Slovakia  
E-mail: andrea.galierikova@fpedas.uniza.sk

## 2. Legal environment for transportation of dangerous goods

The aim of DG regulations and rules is to prevent negative impacts on human life, property and the environment. In addition, the regulations also focus on facilitating trade and the efficient and safe transportation of dangerous goods.

ADR is the European Agreement concerning the International Carriage of Dangerous Goods by Road. The aim of ADR is to increase the safety of international transport by road. ADR consists of the list of dangerous goods, their classification, standards for marking, labelling and packaging of DG and also all types of packaging that can be used, transport equipment (vehicles, construction and equipment), training of drivers, emergency procedures, loading and unloading of cars [5].

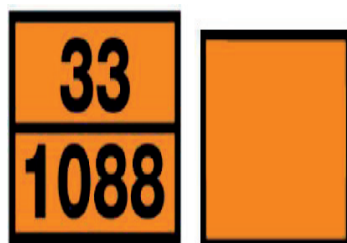

Fig. 1 The sign for labelling of the petroleum

Source: [https://www.unece.org/trans/danger/publi/adr/adr\\_e.html](https://www.unece.org/trans/danger/publi/adr/adr_e.html)

ADR establishes that every dangerous substance must be labelled with the sign containing Hazard Identification Number (HZI) and UN number (Fig. 1). The main advantage of using the UN number is that confusing similar names are removed and language barriers can be overcome. HZI includes two or three numbers representing the degree of danger. The first number shows the primary danger and also classification.

The second number presents the extent of possible hazard (usually is either a zero or a repeating number of the first one). The HZI is displayed on the top row of an orange sign that has to be on the lorry or container which contains dangerous goods. The second row of the orange sign includes the UN number [6].

Dangerous goods with their hazardous properties (such as explosiveness, corrosiveness, toxicity, flammability and radioactivity) are classified into nine classes according to the UN Recommendations on the Transport of Dangerous Goods Model Regulations (Table 1).

- RID presents the Regulations concerning the International Transport of Dangerous Goods by Rail. RID was drawn up by intergovernmental Organisation for International Carriage by Rail (OTIF), comprising 46 member countries. It is established on European territory through European directive 2000/68/EC. To ensure safety and protect the environment, RID sets out a list of hazardous goods which may be carried from loading to delivery place [7]. RID sets out the safety rules for shipper and carrier of dangerous goods which cover:
  - safety measures to be taken during loading and unloading of goods,
  - the full range of checks to be made prior to wagon departure,
  - information about the transport itself: the driver must know the contents of the load and the degree of hazard it presents, and wagons must carry information plates stating the nature of the goods and how hazardous they are,
  - parking and transport conditions
  - steps to be taken in the case of accidents or incidents [8].
- ADN (*The European Agreement concerning the International Carriage of Dangerous Goods by Inland Waterways*) consists of the agreement and annexed Regulations, which aims to:

Classification of dangerous goods

Table 1

| Class  | Examples  |
|--|---|
| 1 explosives   | pyrotechnic material, munitions                     |
| 2 gases  | oxygen, helium, cigarette lighters                  |
| 3 flammable liquids                                  | petroleum products, alcoholic beverages             |
| 4.1 flammable solids                                 | matches, celluloid                                  |
| 4.2 substances liable to spontaneous combustion      | phosphorus, fish meal                               |
| 4.3 substances emitting flammable gases (with water) | metal powders                                       |
| 5.1 oxidising substances                             | hydrogen peroxide                                   |
| 5.2 organic peroxides                                | plastic adhesive                                    |
| 6.1 toxic substances                                 | insecticide, pesticides                             |
| 6.2 substances liable to cause infections            | medical wastes                                      |
| 7 radioactive material                               | uranium metal, nuclear fuel                         |
| 8 corrosives   | car batteries, sulphuric acid                       |
| 9 miscellaneous dangerous substances                 | environmentally hazardous substances, mobile phones |

Source: <http://www.unece.org/?id=3598>

- ensuring safety of international carriage of dangerous goods by inland waterways,
- contributing to the environment protection by preventing any pollution resulting from incidents or accidents during DG carriage,
- facilitating transport operations,
- promoting international trade in dangerous goods [9].

ADN contains rules for packaging of goods, requirements for the construction and operation of vessels for DG transportation. There are also rules for inspections, issue of approval certificates, recognition of classification societies, monitoring and training of experts.

- *IMDG* or the *International Maritime Dangerous Goods* was developed by the International Maritime Organisation (IMO), which is a United Nations specialised agency. IMO deals with two key points for maritime industry: the safety of life at sea and prevention of pollution from ships. The IMO has created two international conventions: the MARPOL Convention (covering pollution prevention) and the SOLAS Convention (covering safety of life at sea).

The International Maritime Dangerous Goods (IMDG) Code was created as a uniform international code for maritime transport of dangerous goods which establishes requirements for packing, container traffic and stowage with reference to the separation of incompatible substances [10]. The aim of IMDG Code is to:

- ensure the safe DG transport
- protect environment and sea from negative impacts
- facilitate the free unrestricted DG movement.

Dangerous goods in IMDG Code have the same classes as in the UN Recommendation, so shipper is able to classify dangerous goods based on the 9 hazard classes, and the labels are internationally accepted [11]. Dangerous goods are uniquely identified by the UN Number and the corresponding PSN (Proper Shipping Name). This number enables quick and precise identification of the designated dangerous goods in the transport chain for correct stowage, handling and separation and also assists in the terms of the emergency.

### 3. The road-sea intermodal flow

In the intermodal transport of DG in combination of *road and sea*, the following parties are usually associated: consignor, forwarder, hauler, shipping company and a port (Fig. 2). The police and the coast guard are providing random checks and controls. The forwarder and the consignor have a contract which contains terms that are more restrictive than those in the case of goods which are not dangerous. A forwarder

also has contracts with haulers and shipping companies. The shipping companies have contracts with the ports, containing loading, unloading and leasing of parking place. The contract relationships describe the forwarder as a party that has a whole responsibility of the dangerous goods for all the transport chain [11]. These responsibilities are presented by different sub-contractors, namely shipping companies and haulers. Basically, forwarding companies have no specific duties and operate more like coordinators between consignor and transport parties.

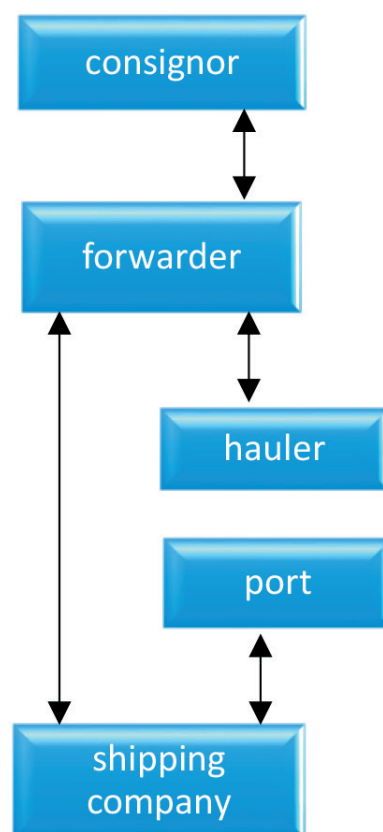

Fig. 2 Intermodal flow of DG  
Adjusted data from [11]

The flow begins at the consignor with an order which is sent to transport company or to a forwarder (Fig. 3). The order is mostly made by phone or email. At first the forwarder receives the order, next he checks, if the order contains the important information such as UN-number, class, packaging group. Then the order of a road or sea transport is carried out. Orders from forwarding companies are usually sent by EDI (for big companies), email or phone (for small companies).

The consignor must verify whether the dangerous goods has approved labelling, marking and packaging. In the terms of rail transport, according to the RID regulation the consignor is responsible for the dangerous goods during whole transport.

When the hauler arrives at the consignor and the driver is present, he is responsible to verify that the loading and lashing are done rightly and also check that the documents from the consignor are correct. ADR establishes that the driver is responsible to deliver the original document to the next transport party in the transport chain. The driver is also responsible for giving information to next transport party of the transport chain on what kind of DG is transported [11].

The responsibility moves from the consignor to the hauler when the dangerous shipment is loaded onto the lorry and the documents are signed. When the lorry arrives and unloads the shipment at the forwarder's terminal, the responsibility moves to the forwarder until the shipment is reloaded and driven out of the terminal. The driver of the lorry is responsible for appropriate labelling before the transport starts. After loading the trailer, the lorry driver transports it to the port. The responsibility moves to the hauler again. When the trailer is parked in the port area, the hauler's task is finished. Information about DG is sent from the forwarder to the shipping company a couple hours before the trailer arrives. As the lorry driver unloads the DG shipment and signs all documents, he can pass the gate with a card that was given to him. When the lorry goes through the gate, it is photographed by circa twenty cameras [11].

The responsibility moves from the hauler to the port since the trailer passes the port's gate and the responsibility of the port will last until the trailer is loaded on the ship. The driver of the trailer must deliver the documents to the shipping company. The requirements for delivery of the documents depend on the different shipping companies. The driver must report the exact location of the parked trailer and its parking number.

Ships that will arrive at the port must notify the port 24 hours before arrival. The shipping company cannot start to plan the loading until all the documents of dangerous goods have arrived. The documents can be an electronic copy or a fax copy. Every shipping company has different requirements for loading process. The port uses a special type of vehicles called tug masters to move the trailers within the port area and drivers who are responsible for loading the trailers on the ships. These drivers get information concerning what kind of dangerous goods will be handled [12].

Most of the dangerous goods can be shipped with "normal" cargo. Commonly the shipping companies do not place any dangerous goods near the safety boats or living places on the ship. Dangerous shipments are often placed on the top deck of the vessel.

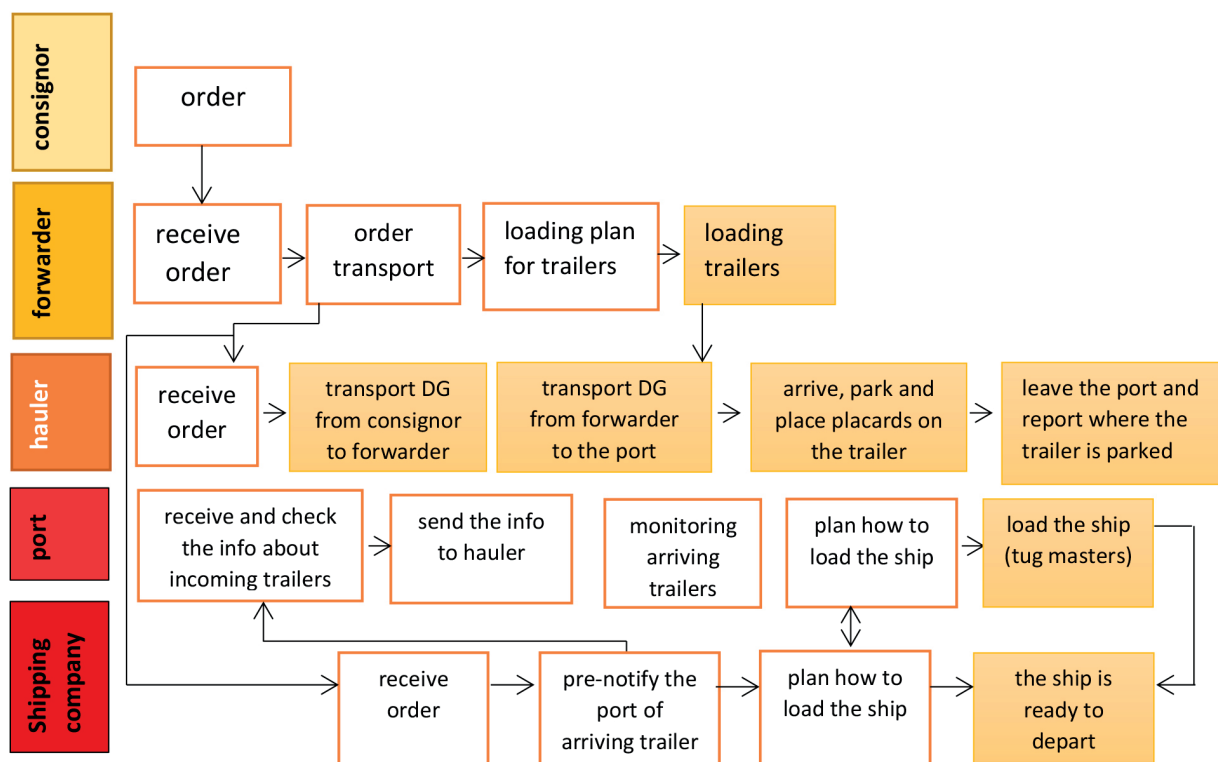

Fig. 3 General flow of DG  
Source: adjusted data from [11]

#### 4. Problems in the flow of dangerous goods

Acknowledgement of DG handling is a problem for the parties that do not often deal with the transportation of dangerous goods. According to the data from Eurostat, in the road transport of DG, 90% of the accidents are caused by human fault, and it refers to the lorry drivers. The dirty and old labels are also a quite common problem (Fig. 4).

If the trailer is used for transportation of one type of dangerous goods all the time, the old and void labels can be used. The most common problem identified by shipping companies is wrong labelling of the units. Sometimes the drivers forget to place one or more labels on the trailer, or labels don't stick to the trailer and fall off due to bad weather [11].

For rail transport of dangerous shipments, missing placards are the most common problem. The rail transport of DG cannot be realised without placards. If an incident occurs during the transport, a rail company is not responsible for the shipment. According to the RID, the consignor is responsible for the goods during the transport [13].

Another possible risk is when the DG in the unit is not properly lashed. When the loading, stowing and securing of the dangerous shipment is not safe, the emergency during the handling and transportation can occur.



Fig. 4 Old labels

Source: [https://gupea.ub.gu.se/bitstream/2077/20851/1/gupea\\_2077\\_20851\\_1.pdf](https://gupea.ub.gu.se/bitstream/2077/20851/1/gupea_2077_20851_1.pdf)

#### 5. Problems at the interfaces

The drivers have knowledge they need to safely load and unload dangerous goods, but the time and stress are the most

common reasons for the mistakes. Leakage is another common emergency. A technical character of the lorry is often a reason. Because the loading is usually driver's responsibility, the hauler's company is the one who is responsible for a possible accident occurring during the loading. Problems also may occur if different types of dangerous goods with different UN number are loaded together (called mixed DG transport). The consignor often plans how to load different classes together, but sometimes he might be wrong and recognise the problem very late. Then the driver has to reload it again. Trailers with dangerous shipments are often arriving late to the port. The reason for this situation are unrealistic or exaggerated haulers' estimates, which consider planned transport times longer or equal to actual transport times. Some hauler companies also proclaim that they can deliver the goods within a certain time just to get more customers or to be able to provide better services [11].

#### 6. Conclusion

As the worldwide supply and demand chains expand, there is a need for a good-working logistic system which provides quick procurement, production, distribution and faster delivery to the customers. To ensure safe and efficient intermodal system, several steps must be followed. The first step is to make the accurate plan of the transportation. The flow begins at the consignors' order. All important elements such as the UN number, packaging group must be correct. In the terms of DG transportation, the proper labelling and packaging are necessary. Each party of the transportation chain must know its responsibilities. Another crucial step is to detect the bottlenecks. Most of the problems that occur in the intermodal transportation of dangerous goods are due to human mistake. For this reason, the education of drivers and haulers in the terms of legal environment, documents and correct and current labelling is very important.

To know and observe the legal environment for DG transportation is another significant point. Although the rules and regulations concerning dangerous goods exist for individual transport modes, there is no rule for intermodal transports. Improved implementation and better harmonisation of rules together with reducing the problem areas in the transport interfaces will not only ensure the safety of dangerous goods transports but will also improve the transport efficiency due to the decreased number of accidents that improved security would lead to.

## References

- [1] European Commission of Ministers of Transport. Terminology on combined transport [www.unece.org](http://www.unece.org/fileadmin/DAM/trans/wp24/documents/term.pdf). Available at: <http://www.unece.org/fileadmin/DAM/trans/wp24/documents/term.pdf> (18. 11 2016).
- [2] RODRIGUE, J., SLACK, B.: *The Geography of Transport Systems*. London : Routledge 2012.
- [3] LIZBETIN, J., CAHA, Z.: *Theoretical Criteria for The Evaluation of the Operational Performance of Intermodal Transport Terminals*, World Multidisciplinary Civil Engineering-Architecture-Urban Planning Symposium (WMCAUS), vol. 161, 1197-1203, 2016, Prague.
- [4] KUBANOVA, J., SCHMIDT, C.: Multimodal and intermodal transportation systems *Communications - Scientific Letters of the University of Zilina*, vol. 18, No. 2, 2016, 104-108, ISSN 1335-4205.
- [5] The European Parliament and the Council of the EU. Directive 2008/68/EC. Available at: [eur-lex.europa.eu](http://eur-lex.europa.eu/legal-content/EN/TXT/HTML/?uri=CELEX:32008L0068&from=EN): <http://eur-lex.europa.eu/legal-content/EN/TXT/HTML/?uri=CELEX:32008L0068&from=EN> (30. 11 2016)
- [6] ADR applicable as from 1 January 2015 Available at: [https://www.unece.org/trans/danger/publi/adr/adr\\_e.html](https://www.unece.org/trans/danger/publi/adr/adr_e.html) (2. 12 2016)
- [7] RID - Convention concerning international Carriage by Rail. Available at: [http://www.otif.org/fileadmin/user\\_upload/otif\\_verlinkte\\_files/07\\_veroeff/99\\_geschuetzt/RID\\_2015\\_e/RID%202015%20E.pdf](http://www.otif.org/fileadmin/user_upload/otif_verlinkte_files/07_veroeff/99_geschuetzt/RID_2015_e/RID%202015%20E.pdf) (2. 12 2016).
- [8] BABIN, M., BUDA, M., MAJERCAK, J.: *Terminals for Transportation of Dangerous Goods*, Transport Means, 16<sup>th</sup> Intern. Conference on Transport Means, Lithuania, 2012
- [9] ADN applicable as from 1 January 2015.UN. [www.unece.org](http://www.unece.org). Available at: [https://www.unece.org/trans/danger/publi/adn/adn\\_e.html](https://www.unece.org/trans/danger/publi/adn/adn_e.html) (2. 12 2016).
- [10] IMO: International Maritime Dangerous Goods (IMDG) Code. Available at: <https://law.resource.org/pub/us/cfr/ibr/004/imo.imdg.1.2006.pdf> (2.11.2016)
- [11] SVENSSON, C., WANG, X.: *Secure and Efficient Intermodal Dangerous Goods Transport*, Master Degree Project, Secure and Efficient Intermodal Dangerous Goods Transport : Gothenburg, 2009.
- [12] SULGAN, M., SOSEDOVA, J.: Rationalization of Internal Transport Operation in the Intermodal Transport Terminals, *Communications - Scientific Letters of the University of Zilina*, vol. 18, No. 2, 2016, 5-10, ISSN 1335-4205.
- [13] UNECE secretariat: Transport of Dangerous Goods - Sixteenth OSCE Economic and Environmental Forum, Prague, May 2008.

Jan Lizbetin - Ladislav Bartuska - Aleksandr Rakhmangulov\*

## COMPARATIVE ANALYSIS OF ALTERNATIVE FUELS USED IN ROAD TRANSPORT

*In recent years, especially alternative fuels have been undergoing significant and rapid development, since the society is aware of the negative impacts of a long term and excessive use of fossil fuels on the environment as well as of the fact that the raw materials are finite. The article shows a new approach to using of alternative fuels in transport in the future. The description introduces both conventional and unconventional fuels. The analysis is focused on the comparison of the fuels in terms of the formation of CO, SO<sub>2</sub>, NO<sub>x</sub> and CO<sub>2</sub> emissions, as well as their energy performance. In the conclusion the paper outlines the future of automobile propulsion in the context of sustainable development of transport.*

**Keywords:** Fuels, alternative fuels, road transport, automobile.

### 1. Introduction

Currently, mainly combustion engines are used in road transport. The history of combustion engines dates back to the 1970's [1 and 2]. A significant increase in using combustion engines was noted ten years later. The first journey undertaken by a vehicle using combustion engine was realized in 1862. It was a three-track vehicle designed by two German engineers, G. W. Daimler and C. F. Benz, a gas-driven vehicle with a cyclic battery ignition system. The maximum speed of the vehicle was 18 km/h, with only as many as 100r/m<sup>1</sup>. The chassis frame was made of steel weldment and the engine in the frame was placed horizontally. Its volume was only 954 cm<sup>3</sup>, with engine power of 2hp (horse power) [3].

As for alternative fuels, their use is usually based on the principle of combustion or electric engines, for example CNG (Compressed Natural Gas), LPG (Liquefied Petroleum Gas), E85 (bioethanol) or hydrogen, only the composition of combustion mixture is different. Hybrid engines are the combination of combustion and electric engines [4].

### 2. Characteristics of conventional fuels

Petrol is a name used for the fractions of crude oil with the boiling range between 30 °C and 200 °C. This temperature range is related to the atmospheric air pressure and is determined by various

mixture compositions. According to types of use, we distinguish between gasoline, avgas (aviation gasoline) and technical petrol, where the first type is considered the most produced one [5].

Gasoline is the mixture of liquid hydrocarbon, with the boiling range between 30 - 215 °C and is intended for the cars equipped with a combustion engine [6]. The specific share of hydrocarbon in gasoline differs depending on its kind, raw materials used and refinery production technology. The basis for further processing is the petrol fraction obtained by the atmospheric distillation. This fraction is regulated by mixing other components in order to get the appropriate octane number, optimum exhaust gas composition etc. [5].

Diesel is a mixture which is composed mainly of paraffinic, cycloparaffinic and aromatic liquid hydrocarbons, with the boiling range between 150 - 370 °C. This basic mixture is usually modified by additives improving low-temperature fuel properties or using. Diesel serves as the fuel for diesel motors, which gave rise to the designation used for the fuel - diesel known from the designations found on the petrol pumps [7].

Diesel is not a special petroleum fraction during the distillation of crude oil but it is prepared by mixing gas oil and kerosene in order to obtain adequate properties. A necessary step for getting the final properties of diesel is desulphurization since the fractions from the distillation contain quite a large amount of sulphur compounds. One of the diesel components is kerosene, an element important for flashpoint, since unlike petrol, diesel ignites spontaneously in

\* <sup>1</sup>Jan Lizbetin, <sup>2</sup>Ladislav Bartuska, <sup>3</sup>Aleksandr Rakhmangulov

<sup>1</sup>The Institute of Technology and Business in Ceske Budejovice, Faculty of Technology, Department of Transport and Logistics, Czech Republic

<sup>2</sup>The Institute of Technology and Business in Ceske Budejovice, Faculty of Technology, Department of Transport and Logistics, Czech Republic

<sup>3</sup>Nosov Magnitogorsk State Technical University, Mining Engineering and Transport Institute, Russia

E-mail: lizbetin@mail.vstecb.cz

compression of its volume in space and does not need a spark for ignition.

A disadvantage of diesel is a content of so called heavy shares which cause sedimentation rate and gradual clogging of high-pressure nozzles in engines. In order to prevent this and at the same time to improve the diesel properties, additives such as depressants, detergents, inhibitors or anti-foaming agents are used [8, 9 and 10]. Depressants have a significant influence on freezing temperature, a process which is referred to as the “paraffination of diesel”. Detergents reduce possible sedimentation which occurs during a long storage of diesel. Inhibitors serve as a protection of friction parts in engines. Anti-foaming agents limit foaming of diesel [11].

### 3. Characteristic of alternative fuels

Nowadays, alternative fuels are considered to be those which replace conventional fuels, such as petrol and diesel. These include also the fuels which are more environmentally friendly. In 1992, the term “alternative fuel” was redefined, covering any fuels of non-oil based origin. This designation can be also used for conventional fuels used in alternative forms. Currently, there are several alternative and reformulated fuels [12 and 13].

Recently, there have been discussions about what type of fuel is the most suitable one for vehicles, since there are limited supplies of gasoline and diesel. LPG, methanol and ethanol seem to reach a deadlock in the future due to their expected further development. Therefore, the best of alternative fuels seems to be natural gas with relatively large reserves, hydrogen and electricity.

The following table (Table 1) gives an overview of alternative fuels used in the present road transport.

Overview of current alternative fuels Table 1

| Substitute for gasoline and diesel oil                                 |
|--|
| <i>Gas</i>   |
| Compressed natural gas (CNG - compressed natural gas)                  |
| Liquefied natural gas (LNG - Liquefied Natural Gas)                    |
| Liquefied petroleum gas (LPG - Liquefied Petroleum Gas)                |
| <i>Oxygen fuels</i>  |
| Alcohols (methanol, ethanol)   |
| ethers (MTBE - methyl tert-butyl ether, ETBE - ethyl tert-butyl ether) |
| <i>Vegetable oils and animal fat</i>                                   |
| <i>Electric or hybrid drive</i>  |
| <i>Hydrogen</i>  |

Source: [14]

Detailed characteristic of each fuel type is included in [15].

### 4. Comparison of alternative fuels

Data on pollutant emissions resulting from using motor vehicles were obtained from the individual cited sources [16 - 20]. The data are taken from testing laboratories while using combustion engines placed in the laboratories with a constant temperature and pressure. These preconditions are necessary for preventing the distortion of resulting values due to surrounding environment. The combustion unit is equipped with a system enabling easy and fast changes of the individual fuels, such as a removable motor head for spark and diesel combustion [21].

The following graphs show the pollutant emissions given in g/km (CO, SO<sub>2</sub>, NO<sub>x</sub>, CO<sub>2</sub>), which arise from the combustion of each fuel.

It results from Fig. 1 that the CO emissions are at the peak during E85 (0.84 g/km) and gasoline (0.76 g/km) combustion. On the contrary, the lowest emissions occur during CNG (0.0225 g/km) combustion. Combusting diesel and LPG produces approximately the same amount of CO (0.41 g/km) emissions.

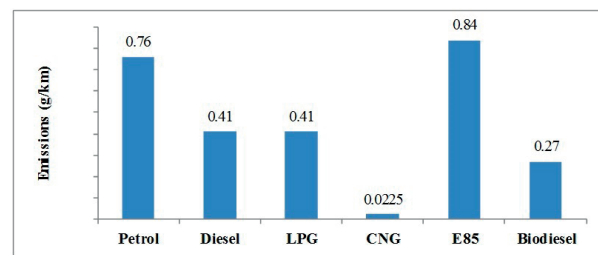

Fig. 1 CO emissions by individual kinds of fuel; source: authors

Figure 2 shows comparison of the sulphur dioxide (SO<sub>2</sub>) emissions produced during the process of combusting various kinds of fuels. The highest SO<sub>2</sub> emissions are produced during E85 (0.078 g/km) combustion. Other emission figures are negligible.

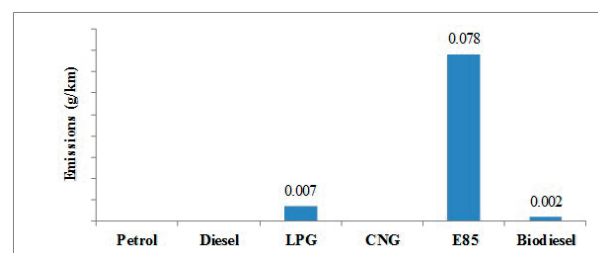

Fig. 2 SO<sub>2</sub> emissions by individual kinds of fuel; source: authors

Figure 3 shows the amount of nitrogen oxide emissions during combustion. The highest amount of pollutants is produced during CNG (0.303 g/km) combustion, while during biodiesel and E85 combustion there is a comparable amount of emissions (0.079 g/km and 0.073 g/km) produced. The lowest amount of nitrogen oxide pollutants is produced during the petrol, diesel and LPG combustion.

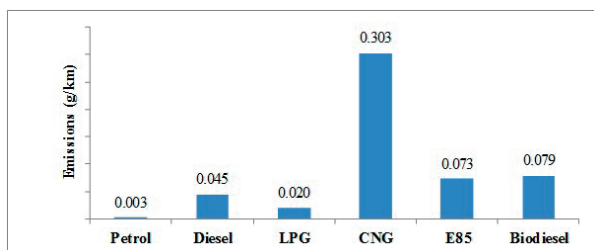

Fig. 3 NO<sub>x</sub> emissions by individual types of fuel; source: authors

Figure 4 compares the amount of CO<sub>2</sub> emissions. The values obtained by combusting petrol, diesel, LPG and E85 are more or less the same. Much lower emissions are produced during CNG combustion (99.75 g/km carbon dioxide). The most environmentally friendly fuel in terms of CO<sub>2</sub> emissions seems to be biodiesel (only 0.039 g/km of CO<sub>2</sub> emissions).

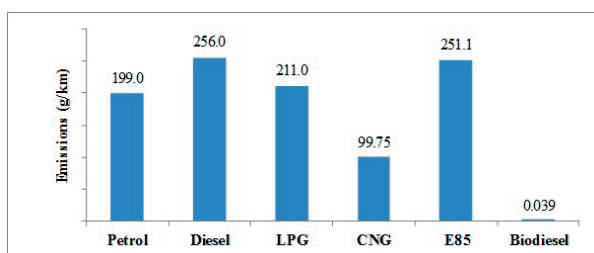

Fig. 4 CO<sub>2</sub> emissions by individual kinds of fuel; source: authors

Figure 5 shows the individual fuels in terms of energy efficiency. From the six chosen fuels the lowest calorific value is for E85 (28.60 MJ/kg), while the highest one is for CNG (55 MJ/kg). Petrol, diesel, LPG (propane and butane) and biodiesel values are about the same.

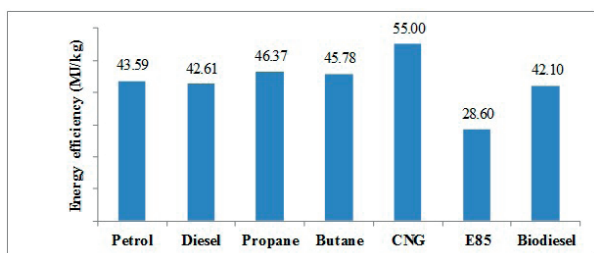

Fig. 5 Energy efficiency by individual kinds of fuels; source: authors

## 5. Conclusion

By comparing individual fuels from an economic point of view it might be concluded that for the users, more preferable (cheaper) ones are those that do not require retrofitting of a storage or standalone unit (e.g. petrol, diesel, ethanol or biodiesel). From this point of view, ethanol combustion is definitely the most preferable one, as it can be mixed with gasoline in any ratio. The only investment required is the mounting of the unit for the combustion of the mixture. As for the fuel consumption, LPG is the most economical one due the lowest price of this fuel in comparison with other fuels [22 - 23].

By comparing the advantages and disadvantages of selected fuels, several possible conclusions can be drawn, depending on the individual needs of the users. From the authors' points of view, CNG or ethanol are the most preferable ones. As for CNG, the main advantage is its low consumption and price while in the case of ethanol the major advantage is the possibility of refuelling this mixture into one tank together with petrol [24].

In the late 1950s, the geologist and geophysicist Marion King Hubbert published his theory of peak oil [25], in which he predicted the culmination of oil production approximately in the 1970s. Subsequently, he predicted a gradual decline of oil production volume, and the end of oil production due to exhaustion of fossil resources in the years 2090 - 2110. For this reason it is inevitable to find alternative ways of automobile propulsion. Natural gas in any form does not guarantee sustainability in transport, since it is a fossil fuel. The future of transport and automobile propulsion is in renewable resources, especially in hydrogen propulsion. The utilization of hydrogen can be practically unlimited. Another benefit of hydrogen is environmental friendliness because hydrogen combustion releases only pure water. Therefore, hydrogen fuel can be considered as the most advantageous alternative fuel of the future.

## References

- [1] HOLESA, L., HRUDKAY, K.: The Impact of Selected Factors of Utility Motor Vehicles Operation Conditions on the Economy Driving, *Communications - Scientific Letters of the University of Zilina*, No. 3, 2015, ISSN 1335-4205.
- [2] TOMASIKOVA, M., BRUMERICIK, F., NIEOCZYM, A.: Vehicle Simulation Model Criterion, *Logi-Scientific J. on Transport and Logistics*, vol. 6, No. 1, 2015, 130-135, ISSN 1804-3216.
- [3] REMEK, B.: *Automobile and its Combustion Engine: Historical Development*, 1<sup>st</sup> ed. (in Czech), Praha : Grada, 2012, 159 p. ISBN 978-80-247-3538-2.

- [4] MITROPOULOS, L. K., PREVEDOUROS, P. D.: Life Cycle Emissions and Cost Model for Urban Light Duty Vehicles, *Transportation Research Part D: Transport and Environment*, 41, 2015, 147-159, ISSN 13619209.
- [5] ROUBICEK, V., RABL, V.: *Petroleum Technology: Alternative Fuels*, 1<sup>st</sup> ed. (in Czech), Ostrava : VSB - Technická univerzita, Fakulta metalurgie a materialového inženýrství, 2000, 267 p., ISBN 80-7078-690-6.
- [6] ZEHNALEK, J.: *Chemicals, Fuels, Oils*, 1<sup>st</sup> ed. (in Czech), Brno : Mendelova zemědělská a lesnická univerzita, 1998, 176 p. ISBN 80-7157-314-0.
- [7] BLAZEK, J., RABL, V.: *Basics of Oil Processing*, 1<sup>st</sup> ed. (in Czech), Praha : Vysoká škola chemicko-technologická v Praze, 2002, 255 p., ISBN 80-7080-473-4.
- [8] SIMKOVA, I., KONECNY, V.: Key Performance Indicators in Logistics and Road Transport, *Logi-Scientific J. on Transport and Logistics*, vol. 5, No. 2, 2014, 87-96, ISSN 1804-3216.
- [9] RIEVAJ, V., STOPKA, O., VRABEL, J., MOKRICKOVA, L., SCHMIDT, C.: The Impact of Air Resistance on the Fuel Consumption in Real Conditions within the Transport Operation, *Communications - Scientific Letters of the University of Zilina*, No. 2, 2016, ISSN 1335-4205.
- [10] OU, K. S., ZHENG, J., LUO, W. J., LI, X. F., HU, H. S., YANG, J. B., ZHENG, J. Y.: Heat and Mechanical Response Analysis of Composite Compressed Natural Gas Cylinders at Vehicle Fire Scenario, *Procedia Engineering*, 130, 2015, 1425-1440, ISSN 18777058.
- [11] MATEJOVSKY, V.: *Automobile Fuels*, 1<sup>st</sup> ed. (in Czech), Praha : Grada, 2005, 223 p., ISBN 80-247-0350-5.
- [12] HAMMADI, M., IEBBA, M., CAMARGO ROSA, F., VENERI, O., CAPASSO, C., PATALANO, S., COPERTINO, G.: *System Approach to the Pre-Design of Electric Propulsion Systems for Road Vehicles*, 1<sup>st</sup> IEEE Intern. Symposium on Systems Engineering, ISSE 2015 - Proc., art. No. 7302762, 2015, 229-236, ISBN: 9781479919208.
- [13] DIMITROVA, Z., MARECHAL, F.: Gasoline Hybrid Pneumatic Engine for Efficient Vehicle Powertrain Hybridization, *Applied Energy*, 151, 2015, 168-177, ISSN 03062619.
- [14] MORAVCIK, L.: *Alternative Propulsion of Road Vehicles* (in Slovak), Doprava a spoje : Zilinska univerzita : Zilina [online]. 20.5.2010, 2010, c. 1, [cit. 2011-04-02]. <<http://fpedas.uniza.sk/dopravaaspoje/2010/1/moravcik.pdf>>. ISSN 1336-767.
- [15] SETKA, O.: *Alternative Propulsion in Road and Rail Transport* (in Czech), *bachelor thesis*, Vysoká škola technická a ekonomická : Ceske Budejovice, 2015.
- [16] HRMADKO, J.: *Combustion Engines: A Comprehensive Overview of Issues for All Types of Automotive Technical Schools*, 1<sup>st</sup> ed. (in Czech), Praha : Grada, 2011, 296 p., ISBN 978-80-247-3475-0.
- [17] MICHAL, P.: *Biogas - Energy from Agriculture* (in Czech), *Biom.cz* [online]. 2005 [cit. 2015-06-25]. [http://biom.cz/upload/6e01d6d4c4835ec93cda508772f3bf6e/biopllyn\\_energie\\_ze\\_zemedelstvi.pdf](http://biom.cz/upload/6e01d6d4c4835ec93cda508772f3bf6e/biopllyn_energie_ze_zemedelstvi.pdf).
- [18] STRAKA, J.: *Hydrogen. Periodic Table* (in Czech), [online], 2015 [cit. 2015-06-16]. <http://www.tabulka.cz/prvky/ukaz.asp?id=1>.
- [19] TOSOVSKY, J.: ELECTRO-FARMING: *The Key to Obtaining very Pure Hydrogen and Cheap Energy* (in Czech), *Biom.cz* [online]. 2002-02-07 [cit. 2015-06-17]. <<http://biom.cz/cz/odborne-clanky/electro-farming-klic-k-ziskavani-velmi-cisteho-vodiku-a-levne-energie>>. ISSN 1801-2655.
- [20] VLK, F.: *Alternative Propulsion of Motor Vehicles*, 1<sup>st</sup> ed. (in Czech), Brno : Frantisek Vlk, 2004, 234 p., ISBN 80-239-1602-5.
- [21] GRAEBENER, S., TARNOWSKI, M., GOEHLICH, D.: *Commercial Vehicle Drive Train Technology and Topology Pre-Selection*, 10<sup>th</sup> Intern. Conference on Ecological Vehicles and Renewable Energies, EVER 2015, art. No. 7113011, 2015, ISBN 9781467367844.
- [22] DORDA, A., NIKOWITZ, M.: *Strategy and Instruments for a Successful Implementation of Electromobility in Austria*, 28<sup>th</sup> Intern. Electric Vehicle Symposium and Exhibition, 2015, EVS 2015, 2015, ISBN 9781510809260.
- [23] WANG, Y., XING, Z., XU, H., DU, K.: Emission Factors of Air Pollutants from CNG-Gasoline Bi-Fuel Vehicles, Part I. Black carbon, *Science of the Total Environment*, 572, 2016, 1161-1165, ISSN 00489697.
- [24] KHAN, M. I., YASMIN, T., SHAKOOR, A.: International Experience with Compressed Natural Gas (CNG) as Environmental Friendly Fuel, *Energy Systems*, 6 (4), 2015, 507-531, ISSN 18683967.
- [25] CAVALLO, A. J.: Hubbert's Petroleum Production Model: An Evaluation and Implications for World Oil Production Forecasts, *Natural Resources Research*, 4 (13), 2004, 211-221, ISSN 1573-8981.

Lenka Cerna - Jozef Danis - Borna Abramovic\*

## THE PROPOSAL OF A TARIFF TAKING INTO ACCOUNT THE RISK FROM UNOCCUPIED CAPACITY OF PASSENGER TRAINS

*There are many different views on perceived benefits and costs of the offered transport services in the market, because each customer gives a different weight to characteristics of these services. The customer thus buys a service from the transport company that offers the highest perceived benefits in relation to the total cost. Therefore it is important to monitor traffic flows of passengers in a long-distance rail passenger transport and in advance specify the expected number of passengers who use this link. Only on the basis of a well-prepared prediction it will be possible to establish an effective session tariff, which ensures reimbursement of all costs to the carrier and also guarantees a reasonable profit. The aim of this paper is to provide a cost analysis of a carrier in passenger rail transport at the risk of unoccupied capacity of a selected train in different variants of its workload and the proposal of a session tariff with respect to this risk.*

**Keywords:** Passenger transport, capacity, risk, calculation of costs.

### 1. Introduction

The term "risk" has many meanings, and is differently defined in the scientific literature, legal norms and various dictionaries. The meaning of this term depends on the field of activity, for which it is defined, on the purpose of the risk definition, and on its subsequent use.

Rail transport as a whole is affected by a number of risks that may arise in different parts of the process and may diversely affect various entities involved in the transport. Risk is defined as an opportunity that it will become something that has an impact on the goals, and is measured by the consequences or an estimate of the probability [1 and 2].

### 2. Risk from unoccupied capacity of a selected passenger train

Risk from unoccupied capacity is one of many risks in the rail passenger transport which may cause a reduction in profit to the carrier, even the incomplete payment of its costs and subsequent loss. This is the risk, when the carrier shares the loss in the operation of passenger rail transport arising from circumstances that can occur before the transport or during

the process of transport and that are not included in the final price of transport [3 and 2].

### 3. Cost analysis for a selected train

Knowing the costs of operations and processes is an essential tool of economic management in the company. In the market environment it is necessary to monitor the costs in several ways. Calculation of own costs in the company should be adapted to the opportunity to analyse and plan the costs for individual activities and processes. Currently, the cost calculations are assigned to the controlling system and are known as cost controlling. It is a broader term which includes not only the monitoring of the costs actually incurred in the activities and processes, but also their planning and control, i.e. we can talk about the cost management in the company [4 and 5].

Total own costs for transport by rail can be calculated according to the formulas that take into account indicators of transport work and relevant cost rates. The basic formula may have the form [4 and 6]:

$$C_t^{total} = C_w + C_l + C_{tc} + C_{lc} + C_{ri} + C_e + C_i \quad (1)$$

\* <sup>1</sup>Lenka Cerna, <sup>1</sup>Jozef Danis, <sup>2</sup>Borna Abramovic

<sup>1</sup>University of Zilina, Faculty of Operation and Economics of Transport and Communications, Slovakia

<sup>2</sup>University of Zagreb, Faculty of Transport Traffic Sciences, Croatia

E-mail: jozef.danis@fpedas.uniza.sk

where:  $C^{total}$  - Total costs of a train

- $C_w$  - Costs of carriages
- $C_l$  - Costs of locomotives
- $C_{tc}$  - Costs of the train crew
- $C_{lc}$  - Costs of the locomotive crew
- $C_{ri}$  - Costs of the rail infrastructure
- $C_e$  - Costs of energy
- $C_i$  - Indirect costs

In the introduction of the analysis of risk from unoccupied capacity of the selected passenger train its identification is important, i.e. detection of all possible effects that cause this risk. For the proper identification of the risk the detailed analysis of the costs which enter this process is significant. The risk identification and analysis of the costs are applied to a model example for the session Bratislava - Trencin - Zilina - Poprad - Kosice with the configuration of the train: locomotive 131 + Ampeer + WRRmeer + 6x Bmpeer [7 - 9]. All needed parameters of the model train are in Table 1.

Basic Parameters of the Model Passenger Train Table 1

| Configuration of the train on the session BA - KE | Weight [t]     | Places for seating |
|---|----------------|--------------------|
| 1x Ampeer   | 49             | 54                 |
| 1x WRRmeer  | 46             | 0                  |
| 6x Bmpeer   | 44             | 76                 |
| Locomotive 363                                    | 87             |                    |
| <b>Total gross weight</b>                         | <b>446</b>     | <b>510</b>         |
| <b>Distance [km]</b>                              | <b>445 km</b>  |                    |
| <b>Infrastructure fee *</b>                       | <b>€461.47</b> |                    |

\* calculated with a calculator ZSR [10 and 11]

Division of costs is often modified by a calculation formula. The transport company may use more these formulas (e.g. for individual organisational units or for individual business areas). An essential aspect of the division of costs in the calculation formula is their division into direct and indirect costs [12 and 13]. Cost analysis for the model train is shown in Table 2.

Calculation of the Costs for the Model Train Table 2

|  |                                      |
|--|--------------------------------------|
| $\Sigma$ carriage kilometres : 3,560               | Costs of the carriages : €2,848      |
| $\Sigma$ train kilometres : 445                    | Costs of the locomotive : €289.25    |
| $\Sigma$ hourly rates for locomotive crew : 6      | Costs of the locomotive crew : €84   |
| $\Sigma$ hourly rates for train crew : 6           | Costs of the train crew : €330       |
| $\Sigma$ gross tonnage kilometres (GTKM) : 105,198 | Costs of the energy : €287.19        |
| Specific consumption (kWh/1,000 GTKM) : 18.2       | Indirect costs : €1,842.82           |
| Travel time (hour) : 5                             | Total costs of the train : €6,142.73 |

The total costs of the model train from Bratislava via Zilina to Kosice are €6,142.73.

The total costs of the model train from Bratislava via Zilina to Kosice are €6,142.73.

#### 4. The proposal of the tariff taking into account the diverse occupancy of the train

The proposal of an optimal tariff (100% occupancy of seats) can be obtained based on the proportion of the total costs and total number of seats when we get the costs of one seat in the whole session. After rounding up the result to an integer, which constitutes a reasonable profit, and from the resulting price for transport over the entire session we will derive prices for transport in individual sections. This will be the basis for creating the relational tariff. The price for individual sections is formed with regards to the distance, but like with the entire session, the results are rounded up, and that should mean a reasonable profit for the carrier. Another form of profit growth is to propose a surcharge to the ticket in the first class, which would mean €4 / one seat.

Revenues are calculated through multiplying the number of occupied seats in the second class with the price for the transport throughout the whole session, plus revenues from the first class (the same way). At the formation of a tariff policy we take into account the fact that not all passengers do travel across the entire session; but the price for transport in the individual sections is higher, and thus the revenues of the carrier will not be reduced. The revenues are calculated as the lowest possible revenues at a given occupancy. Profit is calculated as the difference between revenues and costs (Table 3).

The prices for transport in individual sections are necessarily to be adjusted (raised) in order to cover the total costs also in case the occupancy is not 100%. Total costs are unchanged with respect to occupancy. The calculations with variable occupancy of the train are shown in the following Tables 4 - 9.

The Proposal of a Tariff on the Session Bratislava - Kosice for 100% Occupancy of the Model Train and the Costs of One Seat €12.0446 in the Entire Line Table 3

Costs of one seat in the entire line are €12.0446.

| 100% occupancy | TN       |          | ZA       |          | PP       |          | KE       |          |
|----------------|----------|----------|----------|----------|----------|----------|----------|----------|
|                | 2. class | 1. class | 2. class | 1. class | 2. class | 1. class | 2. class | 1. class |
| Bratislava     | 5        | 9        | 7        | 11       | 11       | 15       | 13       | 17       |
| Trencin        | .        | .        | 3        | 7        | 8        | 12       | 10       | 14       |
| Zilina         | .        | .        | .        | .        | 5        | 9        | 8        | 12       |
| Poprad         | .        | .        | .        | .        | .        | .        | 3        | 7        |

Revenues: €6,846

Profit: €703.27

The Original Tariff on the Session Bratislava - Kosice for 80% Occupancy of the Model Train and the Costs of One Seat €15.0557 in the Entire Line Table 4

Original tariff with a lower occupancy (80%):

| 80% occupancy | TN       |          | ZA       |          | PP       |          | KE       |          |
|---------------|----------|----------|----------|----------|----------|----------|----------|----------|
|               | 2. class | 1. class | 2. class | 1. class | 2. class | 1. class | 2. class | 1. class |
| Bratislava    | 5        | 9        | 7        | 11       | 11       | 15       | 13       | 17       |
| Trencin       | .        | .        | 3        | 7        | 8        | 12       | 10       | 14       |
| Zilina        | .        | .        | .        | .        | 5        | 9        | 8        | 12       |
| Poprad        | .        | .        | .        | .        | .        | .        | 3        | 7        |

Revenues: €5,476.8

Loss: €-665.93

The Changed Tariff on the Session Bratislava - Kosice for 80% Occupancy of the Model Train and the Costs of One Seat €15.0557 in the Entire Line Table 5

Changed tariff with a lower occupancy (80%):

| 80% occupancy | TN       |          | ZA       |          | PP       |          | KE       |          |
|---------------|----------|----------|----------|----------|----------|----------|----------|----------|
|               | 2. class | 1. class | 2. class | 1. class | 2. class | 1. class | 2. class | 1. class |
| Bratislava    | 6        | 10       | 8        | 12       | 11       | 15       | 16       | 20       |
| Trencin       | .        | .        | 4        | 8        | 10       | 14       | 12       | 16       |
| Zilina        | .        | .        | .        | .        | 6        | 10       | 10       | 14       |
| Poprad        | .        | .        | .        | .        | .        | .        | 4        | 8        |

Revenues after the change of rates: €6,700.8

Profit after the change of rates: €558.07

The Original Tariff on the Session Bratislava - Kosice for 60% Occupancy of the Model Train and the Costs of One Seat €20.0743 in the Entire Line Table 6

Original tariff with a lower occupancy (60%):

| 60% occupancy | TN       |          | ZA       |          | PP       |          | KE       |          |
|---------------|----------|----------|----------|----------|----------|----------|----------|----------|
|               | 2. class | 1. class | 2. class | 1. class | 2. class | 1. class | 2. class | 1. class |
| Bratislava    | 6        | 10       | 8        | 12       | 11       | 15       | 16       | 20       |
| Trencin       | .        | .        | 4        | 8        | 10       | 14       | 12       | 16       |
| Zilina        | .        | .        | .        | .        | 6        | 10       | 10       | 14       |
| Poprad        | .        | .        | .        | .        | .        | .        | 4        | 8        |

Revenues: €5,025.6

Profit: €1,117.13

The Changed Tariff on the Session Bratislava - Kosice for 60% Occupancy of the Model Train and the Costs of One Seat €20.0743 in the Entire Line

Table 7

Changed tariff with a lower occupancy (60%):

| 60% occupancy | TN       |          | ZA       |          | PP       |          | KE       |          |
|---------------|----------|----------|----------|----------|----------|----------|----------|----------|
|               | 2. class | 1. class | 2. class | 1. class | 2. class | 1. class | 2. class | 1. class |
| Bratislava    | 7        | 11       | 11       | 15       | 11       | 15       | 21       | 25       |
| Trencin       | .        | .        | 5        | 9        | 13       | 17       | 15       | 19       |
| Zilina        | .        | .        | .        | .        | 7        | 11       | 13       | 17       |
| Poprad        | .        | .        | .        | .        | .        | .        | 5        | 9        |

Revenues after the change of rates: €6,555.6

Profit after the change of rates: €412.87

The Original Tariff on the Session Bratislava - Kosice for 40% Occupancy of the Model Train and the Costs of One Seat €30.1114 in the Entire Line

Table 8

Original tariff with a lower occupancy (40%):

| 40% occupancy | TN       |          | ZA       |          | PP       |          | KE       |          |
|---------------|----------|----------|----------|----------|----------|----------|----------|----------|
|               | 2. class | 1. class | 2. class | 1. class | 2. class | 1. class | 2. class | 1. class |
| Bratislava    | 7        | 11       | 11       | 15       | 11       | 15       | 21       | 25       |
| Trencin       | .        | .        | 5        | 9        | 13       | 17       | 15       | 19       |
| Zilina        | .        | .        | .        | .        | 7        | 11       | 13       | 17       |
| Poprad        | .        | .        | .        | .        | .        | .        | 5        | 9        |

Revenues: €4,370.4

Loss: €-1,772.33

The Changed Tariff on the Session Bratislava - Kosice for 40% Occupancy of the Model Train and the Costs of One Seat €30.1114 in the Entire Line

Table 9

Changed tariff with a lower occupancy (40%):

| 40% occupancy | TN       |          | ZA       |          | PP       |          | KE       |          |
|---------------|----------|----------|----------|----------|----------|----------|----------|----------|
|               | 2. class | 1. class | 2. class | 1. class | 2. class | 1. class | 2. class | 1. class |
| Bratislava    | 11       | 15       | 16       | 20       | 11       | 15       | 31       | 35       |
| Trencin       | .        | .        | 7        | 11       | 19       | 23       | 22       | 26       |
| Zilina        | .        | .        | .        | .        | 11       | 15       | 19       | 23       |
| Poprad        | .        | .        | .        | .        | .        | .        | 7        | 11       |

Revenues after the change of rates: €6,410.4

Profit after the change of rates: €267.67

The carrier may also modify tariff rates with respect to each day of the week according to the occupancy of the train, recapitulation is show in Table 10. From the analysis it is clear that if about 500 people travel in one train from Bratislava to Kosice, the price for transport would be around €13 per one person.

## 5. Conclusion

Own costs in the railway sector are similarly as in the case of other modes of transport influenced by external and internal factors. Among the external factors we can include

mainly fees for the use of railway infrastructure, energy prices, rental (lease payments) of locomotives, carriages and so on. Good predictions on the number of transported passengers and the occupancy of seats on the train are necessary in order to eliminate the risk from unoccupied capacity of the train and then it is possible to propose the tariff which can effectively eliminate this risk. The carrier may also modify tariff rates with respect to each day of the week according to the occupancy of the train. From the analysis it is clear that if about 500 people travel in one train from Bratislava to Kosice, the price for transport would be around €13.

The ticket price for the session BA - KE with the state carrier is currently €18.76 (full price, which is subsidised by

Comparison of the Ticket Price on the Session BA – KE

Table 10

|  |   |                            |                      |  |                      |           |  |           |           |
|--|---|----------------------------|----------------------|--|----------------------|-----------|--|-----------|-----------|
| Comparison of the Ticket Price between BA - KE | <b>Own proposal</b>                             |                            |                      |  |                      |           |  |           |           |
|  | <b>100% occupancy</b>                           |                            | <b>80% occupancy</b> |  | <b>60% occupancy</b> |           | <b>40% occupancy</b>                           |           |           |
|  | 1. class  | 2. class                   | 1. class             | 2. class                               | 1. class             | 2. class  | 1. class                                       | 2. class  |           |
|  | 17  | 13                         | 20                   | 16                                     | 25                   | 21        | 35   | 31        |           |
|  | <b>RegioJet</b>                                 |                            |                      |  |                      |           |  |           |           |
|  | <b>Purchase of a ticket one day in advance*</b> |                            |                      | <b>Purchase of a ticket on Friday*</b> |                      |           | <b>Purchase of a ticket a week in advance*</b> |           |           |
|  | Standard  | Relax                      | Business             | Standard                               | Relax                | Business  | Standard                                       | Relax     | Business  |
|  | 12.1-14   | 15.9-18.7                  | 20.6-25.3            | 12.1-21.5                              | 15.9-28.1            | 20.6-33.7 | 12.1-14  | 15.9-18.7 | 20.6-25.3 |
|  | <b>ZSSK, a.s. (state carrier)</b>               |                            |                      |  |                      |           |  |           |           |
|  | <b>2. class</b>                                 | <b>CLASIK<br/>RAILPLUS</b> |                      |  |                      |           |  |           |           |
| 18.76  | 14.07   |                            |                      |  |                      |           |  |           |           |

\*Ticket price depends on the time of travel during the day (5:33 AM, 11:33 AM, 5:33 PM)

the state); private carrier RegioJet offers the price from €12.1 to €33.7 for this session, however this price depends on three factors (the day of ticket purchase, travel time and the class of a carriage). In our proposal, which takes into account the risk from unoccupied capacity of a train, the ticket price is dependent on the occupancy of the train. In the case of 40% occupancy of the train, the ticket price in own proposal is lower than the price level with a private carrier in the highest class during the rush hour. At formation of the tariff policy

it is important to take into consideration the forecast of development of the number of passengers.

**Acknowledgements**

The paper is supported by the VEGA Agency under Project 1/0095/16 “Assessment of the quality of connections on the transport network as a tool to enhance the competitiveness of public passenger transport systems”

**References**

[1] DVORAK, Z. et al.: *Risk Management in Rail Transport*, University of Pardubice, Institute of Jan Perner, 1<sup>st</sup> ed., 2010, ISBN 978-80-86530-71-0

[2] POLIAK, M., KRIZANOVA, A., SEMANOVA, S., GAJANOVA, L.: The Influence of Contract Form Choice of the Transport Services Ensuring on Performance Contracting Entity Requirement. *Transport Problems = Problemy Transportu: Intern. Scientific J.*, vol. 9, No. 4, 2014, 153-161, ISSN 1896-0596

[3] GASPARIK, J., SIROKY, J., PECENY, L., HALAS, M.: Methodology for Assessing the Quality of Rail Connections on the Network. *Communications - Scientific Letters of the University of Zilina*, vol. 16, No. 2, 2014, 25-30. ISSN 1335-4205

[4] DOLINAYOVA, A., LOCH, M., KANIS, M.: Modelling the Influence of Wagon Technical Parameters on Variable Costs in Rail Freight Transport. *Research in Transportation Economics*, 2015, vol. 54, 33-40.

[5] STOPKA, O., SIMKOVA, I., KONECNY, V.: The Quality of Service in the Public Transport and Shipping Industry, *Nase More*, Dubrovnik: University of Dubrovnik, vol. 62, Special Issue, 2015, 126-130. ISSN 0469-6255

[6] NEDELIAKOVA, E., DOLINAYOVA, A., GASPARIK, J.: Methodology of Transport Regulation in the Slovak Republic, *Periodica Polytechnica Transportation Engineering*, vol. 38, No. 1, 2010, 37-43.

[7] MAJERCAK, J., KUDLAC, S., PANAK, M.: *Sustainable and Economically Efficient Five-point Supply Chain Management*. Proc. of 20<sup>th</sup> intern. scientific conference Transport Means 2016, Kaunas University of Technology, Kaunas University of Technology, 2016. 65-70, ISSN 1822-296X.

[8] GASPARIK, J., GABOROVA, V., LUPTAK, V.: *Process Portal for Railway Cargo Operator with CRM Support*, Proc. of the 20<sup>th</sup> intern. conference Transport Means 2016, October 5-7, 2016, Kaunas University of Technology, 2016, 245-249, ISSN 1822-296X.

[9] KENDRA, M.: *Integration of Individual Car Transport and Public Passenger Transport in Cities*, Proc. of OPT-i 2014 - 1<sup>st</sup> intern. conference on Engineering and Applied Sciences Optimization, 2014, 1582-1592, ISBN: 978-960999946-5

- [10] Document about the determination of charges for access to railway infrastructure valid from December 2, 2010.
- [11] Document about the determination of charges for access to railway infrastructure valid from 24 May 2012, No. 7, 2012, which amends the previous one.
- [12] STOPKA, O., PONICKY, J., CHOVANCOVA, M., ZITRICKY, V.: Draft Method for Determining the Number of Checking Devices Utilized within the Regional Passenger Transport, *Nase more*, vol. 63, No. 3, 2016, 200-203, ISSN 0469-6255.
- [13] LALINSKA, J., CAMAJ, J., NEDELIAKOVA, E.: *Possibilities and Solutions of Compensation for Delay of Passenger Trains and Their Economic Impacts*, Proc. of the 19<sup>th</sup> intern. conference Transport Means 2015, October, 2015, Kaunas University of Technology, 2016, 729-733, ISSN 1822-296X.

Pawel Drozdziel - Kamil Wawer - Radovan Madlenak - Murat Omarbekovich Mussabekov\*

## CONCEPTS OF LOAD HANDLING DEVICES, ADJUSTED TO LIGHT GOODS VEHICLES OF THE WEIGHT UP TO 3.5T

*The main aim of the article is to present three concepts of load handling devices, adjusted to light goods vehicles of the weight up to 3.5t. The design issue commissioned by Poczta Polska - the Polish Post was analysed. On the basis of the analysis the design assumptions were taken to design a device. The construction and the method of operation of the design structures suggested by the author were discussed. All the concepts were compared with one another with the use of a SWOT analysis.*

**Keywords:** Load handling devices, loading board, postal transport.

### 1. Introduction

The process of the goods unloading may be aided with the use of stationary and mobile devices. Moreover, some devices facilitating unloading may be placed on the vehicles. The examples of the stationary devices located in fixed places, where the goods are being relocated, are: cranes, gantry cranes, conveyors, compressors and pumps dedicated to reloading liquid and dry goods. As far as reloading devices are concerned, though, they are among others: forklifts, loaders, straddle carriers and lift trucks [1 and 2].

The idea of placing reloading devices on the vehicles has numerous advantages. The most vital one is the independence from accessibility of mobile reloading devices in the target unloading or reloading place. It fastens the whole process of goods transportation [3 and 4]. That is why such devices are, depending on the possibilities and needs, more and more often mounted on transporting vehicles. The examples of such devices may be: loading platforms, lorry-mounted cranes, movable floors, dump bodies (in case of unloading) [1].

According to PN-EN 1756-1 norm from November 2008, an access loading platform is defined as an elevating device to be installed on or inside a wheeled vehicle that is used to reload or unload this vehicle [5]. Loading platforms are often called cargo winches or load boards. Such devices are often used in delivery vans or lorries. Loading platforms are also often installed on semitrailers or trailers. Such devices

are designed to elevate goods placed on the pallets, in carts, baskets, cases, containers, packets and others. It must be stressed out, though, that the use of a loading platform eliminates the most burdensome and laborious part of work connected with reloading [6 and 7]. Loading platforms are especially useful during distribution of large amounts of goods placed on pallets. They enable loading and unloading goods by just one person with the use of pallet trucks [8].

The aim of this article is to present three conceptions of devices realising the procedure of goods reloading, with special attention paid to construction and mode of operation of the described mechanisms. The present article consists of four parts. The first one focuses on the construction problem that the authors faced. The second one discusses construction assumptions and describes what requirements should the created construction meet to operate safely and effectively. The following part presents three variants of devices realising the procedure of goods reloading, their essence and construction. In the summary, all concepts are compared and, with the use of the SWOT analysis, the best one is chosen.

### 2. Problem analysis and specification

The problem that is the subject of the article was reported by the Lublin branch of PocztaPolska (Polish Mail - hereinafter referred to as PP). The institution had ordered the project that was aimed at rationalising the reloading procedure

\* <sup>1</sup>Pawel Drozdziel, <sup>1</sup>Kamil Wawer, <sup>2</sup>Radovan Madlenak, <sup>3</sup>Murat Omarbekovich Mussabekov

<sup>1</sup>Institute of Transport, Combustion Engines and Ecology, Lublin University of Technology Lublin, Poland

<sup>2</sup>Faculty of Operation and Economics of Transport and Communications, University of Zilina, Slovakia

<sup>3</sup>Kazakh Academy of Transport and Communications named after M. Tynyshpayev, Almaty, Kazakhstan

E-mail: p.drozdziel@pollub.pl

in wagons in the Lublin branches of PP. A person who is directly responsible for and takes part in the reloading process is the driver of a light commercial vehicle. Light commercial vehicles are some of the most common vehicles on the roads of many cities [9]. The project solution is dedicated to the following types of wagons: Peugeot Boxer, Fiat Ducato, Mercedes Sprinter, etc.

The drivers of delivery vans are obliged to deliver the parcels safely and in due time from the central base located in the city suburbs to the local PP branches within the whole area of the city of Lublin. All loads (letters and parcels) are packed into special cover boxes. An empty cover box weighs 1 kg, and a fully loaded- 10 kg. Cover boxes are designed to make it possible to put them on top of one another. For more efficient and comfortable displacing, cover boxes are equipped with handles. The process of the cover boxes' loading and unloading is carried out manually. A driver is able to lift 5 boxes weighing ca. 50 kg at once, and walk a certain distance. At every target point, the driver has to unload the loads he needs and then load new goods. Both of these operations are carried out manually. It is connected with the driver's stepping on the load bed floor and displacing the load multiple times. Such type of the loading-unloading process organisation requires substantial effort on the part of the driver, which is, in turn, a cause of frequent injuries. Loading is time-consuming, which influences the decrease in the transport effectiveness.

The target solution assumes loading the cover boxes on specially designed transportation carriages. In order to decrease the workload on the part of the driver and time of the goods loading and unloading, it is necessary to use the rationalising construction. The introduction of the new solution will facilitate the driver's work and reduce the transportation time. A steel transportation carriage designed for vehicles owned by PP is an example of such solution.

### 3. Construction assumptions of the project

Construction assumptions of the project describe the device's working, its exploitation conditions and requirements that it will have to meet [10]. While working on the reloading construction's conception dedicated to delivery vans, eight construction assumptions were introduced. A part of them results from the nature of work of the reloading devices, while the other ones were proposed by the client.

1. User's safety.
2. The construction's load capacity up to 500 kg.
3. Lift height, which is equal to distance between the ground and the level of the van's load bed floor.
4. Low unladen kerb mass between 150 kg and 250 kg.
5. Minimised construction size.

6. The device's construction will not interfere with the van's construction.
7. Construction's reliability.
8. Low maintenance costs and accessibility of the used parts.

These assumptions determine the range of solutions that may be used to work on the technical problem and define the character of the elements that meet the defined challenges.

### 4. The conceptions of the construction problem's solutions

This part of the article presents three variants of the construction problem's solutions. The construction and principle of operation of each design are described. Advantages and disadvantages of solutions are analysed and referred to the construction assumptions.

#### 4.1 The scissor lift conception

The first conception is a mobile platform with scissor lift driven by an electric motor. A mechanism responsible for lifting the load is a scissor lift. It is widely used in garages to lift the cars. The construction consists of electric motor, toothed gear, screw, screw cap, bearing with bearing mounting, strands, loading platform, wheels, transport grip and beams with limit switches. All the elements of the designed reloading device are placed on a perpendicular frame made of structural sections. The driving torque of the scissor lift is provided by a constant voltage electric motor. The size of the driving torque is changeable due to the use of the toothed gear. The toothed gear's output was connected with the power screw. Rotation of the screw triggers feed of the cap that has pinned connection with one of the strands' ends. Rotary movement of the screw results in up or down movement of the strands. Aluminium loading platform where the load is placed is attached to another end of the strands.

In order to impose the right work upon the platform, two limit switches are attached to the frame. They are responsible for cutting the power supply off of the motor when the minimum of maximum lift height of the platform is achieved. In order to work well, the main limit switch is attached to a fold-up beam. The beam must be placed in vertical position before turning the platform on. When the reloading is finished, the beam must be lowered. In order to facilitate the transport, wheels and transport grip will be attached to the platform frame. The motor will be supplied with the use of buffer from accumulator and alternator. Total construction mass will not exceed 25 kg.

The advantage of the presented solution is the adjustable height of the load lift. It is realised thanks to the increased

number of motor rotations and, thus, through the increased screw cap feed in the cap-screw system. Moreover, one must take into consideration that with the planned components configuration, the planned platform mass is much lower than the proposed one in the construction assumptions, which is a considerable advantage. In addition, when choosing the electric motor with parameters able to provide the load capacity of the whole construction weighing a half of tone, the second construction assumption relating to the system's load capacity is complied with as well. It should be noted that when folded, the platform size is considerably small.

A disadvantage of the scissor lift is the mode of the electric motor supply. The conception assumes the power feed supply with the use of a built-in accumulator and alternator. Such solution requires an interference with the electric supply of the vehicle and installation of an additional group of conductors and power supply sockets in the van. Since the platform is not attached to the vehicle, a driver will be forced to take it out from the case before each and every use, which requires additional effort on his part. Moreover, everyday control of the accumulator condition must be taken into consideration as well. The proposed construction may be susceptible to external conditions, such as vibration, hits, dirt, that may considerably decrease its reliability. What is more, when the mechanism is broken, the costs of service may be relatively high - especially in the case of the electric motor damage.

#### 4.2 The lever-spring conception

The second proposition of the construction aimed at rationalising the loading and unloading processes, is a mobile loading-unloading platform with a lever-spring drive. The conception is based on a lever-spring mechanism that is used, among others, in the furniture assembly. The device consists of frame, strands, pins, platform, gas spring, ratchet mechanism and steering handle. The device's base is a rectangular frame made of structural sections. The frame is equipped with wheels in order to position the construction against a delivery van. Four strands of the same length are attached to the frame so that the ends of the two of them are installed at the opposite sides of the frame. Strands have pinned connection with the frame, which enables them to move on the circle. The connection of strands with the base is realised with the use of pins. An aluminium loading platform has pinned connection with another strand's end. A steering handle controlling the loading platform's position is attached to one strand. A maximum height of the platform is equal to joints' spacing in the pins.

Moreover, gas springs enhance the platform lowering. A mounting rod is placed crosswise through the middle of the

opposite strands pair. It is responsible for fastening the first joint to the gas springs. The catch pawl of the gas spring's piston rod is attached to the base frame. A key aspect in this case is to choose the appropriate parameters of the spring. The force that aids lifting should be high enough to lift the platform and, at the same time, limited to a safe value in order to provide a controlled platform lift. An appropriate piston rod stroke must be selected. It is possible to add a mechanism to control the platform lift. A ratchet mechanism may be mounted as well. Depending on the platform lift, this mechanism maintains the load at the requested height. Moreover, the ratchet mechanism protects from a sudden failure of the gas spring.

The advantage of the construction is a possibility to adjust the lifting height with regard to the position of the van's load bed floor. The use of ratchet mechanism allows for stopping the platform at the requested height. Another advantage is relatively low unladen kerb mass, similar to the scissor lift. The device, in the proposed configuration, does not take much space, which increases the van's loading capacity. The proposed solution does not interfere with the vehicle construction. It is a separate mechanism aimed at lifting the loads. Moreover, this construction does not require using specialised parts, which decreases the production costs.

As far as the disadvantages are concerned, it is necessary to position the platform against the vehicle's load bed floor. The device must be set in a position that enables to transport the load from the platform to the van's load bed floor. In addition, gas springs aid the mechanism's work at the fixed loads. It means relatively narrow range of possible load weight that will allow for the faultless work of the system. What is more, the platform is susceptible to external conditions, such as vibration, dirt or hits.

#### 4.3 The mechanical loading platform with unfaced surface conception

The third conception that was proposed is a mechanical loading lift. This proposition was based on the idea of loading lifts driven hydraulically. Its characteristic is the fact that when folded (the platform is inside the vehicle's loading space), the top elements of the device are not faced with each other.

The mechanical loading platform with unfaced surface consists of: work-rest blades with strengthening elements and fixing kits, support rollers with fixing flat bars, frame bearer, rope winch, steel cable, blocks, support wheels, support wheels' blocking mechanism, a rod connecting support wheels with platform and reinforcing strands with slide ways. Aluminium or steel work support blades are attached to the vehicle floor with the use of fixing kits. As opposed to the previous conceptions of the reloading device,

the third proposition is based on the combination of loading lift with the vehicle's load bed floor. It is, though, based on the project assumption that excludes the possibility of the vehicle construction's modification.

Reinforcing elements in the form of aluminium or steel flat bars are welded between the work support blades. The reinforcing elements system creates a frame that is to stabilise and bind all the work support blades. The work support blades are presented in Fig. 1 with number 1. The work support blades are, in substance, a flat bar with a perpendicular oblong cut milled on its surface. Such cut is to drive the support rollers. The rollers are attached to the frame bearer with the use of fixing flat bar. The flat bar was cut out of a sheet metal plate and welded in the frame bearer.

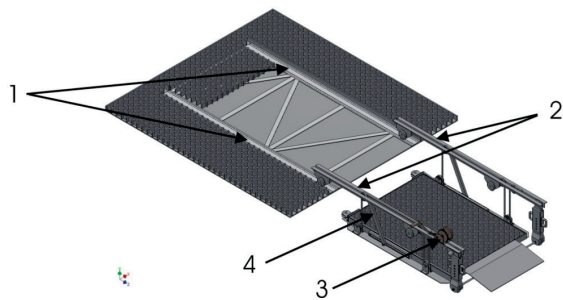

Fig. 1 Figure of loading space with mechanical loading platform with unfaçed surface

The frame bearer consists of two non-equal-sided angles. They were attached with the use of welded standoffs. Such solution creates a spare space between the surfaces of angles' legs. The longer legs of the angles are oppositely directed. The shorter legs of the angles are faced. The holes aimed to drive the pins blocking the slid able platform position, are cut on one end of the frame bearer's angle. Frame bearer with support rollers are presented in Fig. 1 with number 2. The rope winch is attached to the faced surface of the frame bearer with the use of screws or blind rivets. The winch's characteristic is friction brake and ratchet mechanism, thanks to which it is possible to suspend and stop the load at the requested height. Due to change diameter of winch's cylinder, it is possible to adjust time of lifting cargo.

A steel cable with a hook is reeled on the rope winch's hoisting drum. The cable is driven through the system of mobile and immobile blocks that are responsible for the distribution of internal forces during the load lifting.

The blocks are attached to the frame bearer between the angles' legs with the use of pin and sleeves. In this system, they are treated as immobile blocks. The blocks are chosen in such a way to ensure that their load capacity is higher than internal forces in the cables. There are possibility to increase the weight of cargo due to choose proper blocks, it means block with

proper bearing. The blocks model and their attachment are presented in Fig. 1 with number 3.

Support wheels have pinned connection with the end of frame bearers, from the vehicle's side, between the angles. Their task is to hold the frame bearer in horizontal position and to transfer internal loads when lifting the platform with the load.

In order to provide a regulated height of the support wheel, two closed profiles of different sizes and placed telescopically were used. The profiles' characteristics are holes cut on the lateral surface of the walls. Determining the support wheel's height and blocking the line feed is carried out with the use of a pin build-in concentrically in the profiles' holes. The porters are attached to the outer profile, thanks to which an operator is able to rotate the support wheels and determine the angular orientation. A wheel enabling the support wheel's and, at the same time, the whole platform's feed is mounted on the inner profile.

A mechanism blocking the support wheels' position is attached to one end of frame bearer, from the vehicle's side. It consists of a handling plate with a porter, aluminium or steel mounting angle, blocking pins with variable diameter and a return spring. Blocking mandrels from the smaller diameter's side were welded to the end face of the handling plate with a porter. The characteristic of the blocking mandrels is the change of diameter in a stepped manner. Spacing of pins attached to the plate corresponds to the spacing of holes cut in the frame bearer. The mechanism's task is to block the extreme positions of the support wheels. It is realised with the use of concentric inserting of the blocking pins into the holes placed in the mounting angle, frame bearer angle and on the bearing surface of the support wheel. After passing all the holes, the pin is in the off-position.

The loading platform's landing consists of angles, landing grid and blocks. The loading platform's frame is made of aluminium angles. They are welded in a rectangular shape. One leg of all angles is turned inward the frame space. Moreover, additional angles were welded with the longer sides of the rectangular landing. Unwelded legs of the inner angles create the seating surface of the landing grid, where the load will be placed. The blocks are attached to the unwelded legs of outer angles. In the frame bearer-landing system, they are treated as immobile blocks. Two additional blocks are attached to the end face of the landing's shorter side. They are placed on the extreme ends of the angle. Moreover, in order to facilitate putting the load on the platform, a tracking frame is attached to the landing. It is mounted with the use of hinges. Between the frame bearer's angles, the aluminium strands are mounted. Their task is to eliminate moving of the platform perpendicularly to the vehicle's length and to stabilise the platform. One side of strands has the pinned connection between the angles. The other side is connected with the work

support blade with the use of a pin. The work support blade is welded to the platform landing. The platform's move stabiliser is presented in Fig. 1 with number 4.

The manner of the loading platform operation is similar to the classic loading lifts driven hydraulically. When folded, the landing, together with the frame bearer and support wheels, are placed in the vehicle's loading space. The operator pulls the frame bearer out of the loading load bed floor by pulling the handles placed on the support wheels. When the support wheels are beyond the van's loading area, the operator releases the hold of the support wheels position by pulling the handling plate. It allows for the 180° rotating of the support wheels. The supports are blocked in extreme positions.

This conception's advantage is an easy way to regulate the platform loading capacity. The use of blocks and an appropriate cable allows for regulating the whole device's loading capacity. The load capacity may be easily increased by changing the rollers number. Moreover, the use of the rope winch enables a smooth regulation of the lifting height. An important advantage of the rope winch construction is the friction brake with pawl that blocks the landing automatically on the requested height. Depending on the used materials, the anticipated unladen kerb mass of the construction is between 150 kg and 250 kg. The conception of the platform with unfaced surface assumes mounting it to the original equipment of the van's load bed floor. It means the interference with the vehicle original structure. The parts the platform is made of are resistant to external conditions and difficult working environment. In addition, a majority of the platform components is catalogued and easily accessible, which considerably decreases the costs of manufacturing.

A very shape of the construction is its disadvantage. The frame bearer in folded position sticks out from the lining on the load bed floor.

## 5. SWOT analysis of the different lifts conceptions

According to the technical objects construction scheme, one of the three proposed conceptions was chosen. In order to compare all of them and choose the best one, the SWOT analysis was conducted. It is an effective method of the technical projects' strengths and weaknesses identification, and of opportunities and threats determination that are connected with implementation of a chosen conception [11].

Literature research and opinion of experts was used for the identification and classification of the most important internal and external factors in four categories [12]:

1. Strengths- characteristics of the project that give it an advantage over others
2. Weaknesses- characteristics that place the project at a disadvantage relative to others

3. Opportunities- elements that the project could exploit to its advantage
4. Threats- elements in the environment that could cause trouble for the project.

In chapter two, eight construction assumptions that guided the whole process of the construction problem solution were discussed. Table 1 presents the comparison of the conceptions and enumeration of the construction assumptions they meet.

Table 1 indicates that the third variant- the mechanical loading platform with unfaced surface- meets the highest number of the construction assumptions. Taking into consideration the fact that the other conceptions do not meet at least two construction assumptions, and by comparing opportunities and threats for the project, the third variant was chosen the best solution of the author's reloading device.

## 6. Summary

The article presents conceptions of devices facilitating the process of goods reloading. Based on discussions with the Management Board and interviews with drivers hired by Poczta Polska (Polish Mail), eight construction assumptions were accepted. They were a starting point for designing devices aiding the procedure of the parcels reloading.

The first conception is based on the use of an electric motor and a scissor lift mounted on a ramp. Power needed to feed the electric motor is supplied with the use of buffer from accumulator and alternator.

The second proposition is an autonomic device with gas springs. As in the first case, it is based on a frame made from sections. The construction consists of frame, strands and platform that have pinned connections. A handle attached to one strand regulates the platform's position.

The third project is a lifting platform mounted inside the vehicle's load bed floor. This solution was inspired by loading platforms driven hydraulically. In contrary to the available and used solutions, a power drive was used in the presented conception. The force needed to lift the load is decreased by using an appropriate system of blocks. The device's characteristic is the unfaced upper surface, unfaced frame bearer with the lining and floor surface.

There are a lot of other solutions available on the market offered by specialised engineering companies. However, it must be noted that the proposed device aiding the reloading procedure is dedicated to the client's needs, i.e. Poczta Polska (Polish Mail). The prepared conception is a compromise between the authors' design vision and the client's expectations.

The conceptions comparison with the use of SWOT analysis

Table 1

| <b>Variant 1- The scissor lift conception</b>  |   |
|--|---|
| Strengths:   | Weaknesses:   |
| <ul style="list-style-type: none"> <li>✓ User's safety</li> <li>✓ The construction's load capacity up to 500 kg</li> <li>✓ Lifting height</li> <li>✓ Low unladen kerb mass</li> <li>✓ Minimised construction's size</li> </ul> <p style="text-align: center;">The number of the construction assumptions it meets: 5</p>   | <ul style="list-style-type: none"> <li>✗ Interferences in the vehicle construction</li> <li>✗ Relatively increased reliability</li> <li>✗ High costs of prospective repairs and limited accessibility of the catalogue parts</li> </ul> <p style="text-align: center;">The number of the construction assumptions it does not meet: 3</p> |
| Opportunities:   | Threats:  |
| <ul style="list-style-type: none"> <li>○ The possibility of customised modifications</li> </ul>  | <ul style="list-style-type: none"> <li>• A possible lack of support after launching the series production</li> <li>• A possible breach in patent law of the other scissor lifts' producers.</li> </ul>  |
| <b>Variant 2: The lever-spring conception</b>  |   |
| Strengths:   | Weaknesses:   |
| <ul style="list-style-type: none"> <li>✓ User's safety</li> <li>✓ Lifting height</li> <li>✓ Low unladen kerb mass</li> <li>✓ Minimised construction's size</li> <li>✓ The lack of interference in the vehicle construction</li> <li>✓ Low maintenance costs and accessibility of the used parts</li> </ul> <p style="text-align: center;">The number of the construction assumptions it meets: 6</p>   | <ul style="list-style-type: none"> <li>✗ Construction's reliability</li> <li>✗ The construction's load capacity up to 500 kg</li> </ul> <p style="text-align: center;">The number of the construction assumptions it does not meet: 2</p>   |
| Opportunities:   | Threats:  |
| <ul style="list-style-type: none"> <li>○ The possibility of the constructor's support due to the project's innovation</li> <li>○ The possibility of the project development when it comes to lifting the loads of the same height every time</li> </ul>  | <ul style="list-style-type: none"> <li>• The possibility of the lack of interest on the part of companies due to the device's lack of versatility</li> </ul>  |
| <b>Variant 3: The mechanical loading platform with unfaced surface conception</b>  |   |
| Strengths:   | Weaknesses:   |
| <ul style="list-style-type: none"> <li>✓ The construction's load capacity up to 500 kg</li> <li>✓ Lifting height</li> <li>✓ Low unladen kerb mass</li> <li>✓ Minimised construction's size</li> <li>✓ The lack of interference in the vehicle construction</li> <li>✓ Construction's reliability</li> <li>✓ Low maintenance costs and accessibility of the used parts</li> </ul> <p style="text-align: center;">The number of the construction assumptions it meets: 7</p> | <ul style="list-style-type: none"> <li>✗ User's safety</li> </ul> <p style="text-align: center;">The number of the construction assumptions it does not meet: 1</p>   |
| Opportunities:   | Threats:  |
| <ul style="list-style-type: none"> <li>○ The possibility of the constructor's support due to the project's innovation</li> <li>○ The possibility of optimising the size, geometry and materials of the designed construction</li> <li>○ Enhancement of the functionality after allowing the possibility of electric supply.</li> </ul>   | <ul style="list-style-type: none"> <li>• The possibility of the lack of interest on the part of companies due to a health risk for the user.</li> </ul>   |

**References**

[1] PROCHOWSKI, L., ZUCHOWSKI, A.: *Automotive Vehicles* (in Polish), Technika transportu ladunkow : Wydawnictwa Komunikacji i Lacznosci, Warszawa 2009

[2] VACULIK, J., KOLAROVSZKI, P., TENGLER, J.: Results of Automatic Identification of Transport Units in Postal Environment, *Transport and Telecommunication*, vol. 13, No. 1, 75-87.

- [3] COREJOVA, T., IMRISKOVA, E.: Convergence at the Postal Market, *Eksploatacja i niezawodnosc-Maintenance and Reliability*, vol. 1, No. 3, 2008, 74-76.
- [4] COREJOVA, T., ROSTASOVA, M., CHRENKOVA, A., MADUDOVA, E.: Regional Dimensions of Knowledge Processes in the Sectors of Transport and Logistics and ICT in the Zilina Region, *Communications - Scientific Letters of the University of Zilina*, vol. 15, No. 2, 2013, 25-33.
- [5] Norma PN-EN 1756-1:2008 - Tail Lifts. Platform Lifts for Mounting on Wheeled Vehicles. Safety Requirements. Part 1: Tail Lifts for Goods (in Polish).
- [6] LUBCZYNSKI, M., MAZUREK, S.: *Self-unloading Car* (in Polish), Wydawnictwa Komunikacji i Łączności : Warszawa 1978.
- [7] MADLENAKOVA, L., MATUSKOVA, M., HRUDKAY, K.: *Intermodal Transport Terminals as Part of the Postal Transportation Network*. Transport Means 2016: 20<sup>th</sup> intern. Scientific Conference, Kaunas University of Technology, ISSN 1822-296 X, 565-561.
- [8] MADEJ, B., MICHNIK, J., MADEJ, R., KURCZ, J.: *Road Transport of Passengers and Goods* (in Polish), Podręcznik kierowcy zawodowego. Akademia Transportu i Przedsiębiorczości Sp. z o.o. : Warszawa 2014.
- [9] ELLISON R., TEYE C., HENSHER, D.: Modelling Sydney's Light Commercial Service Vehicles. *Transportation Research Part A: Policy and Practice*, vol. 96, 2017, 79-89.
- [10] DIETRICH, M. (red.): *Fundamentals of Machine Design* (in Poland), Tom 1. WNT, Warszawa, 1999.
- [11] KOZMINSKI, A., PIOTROWSKI, W. (red.): *Management. Theory and Practice* (in Polish), Wydawnictwo Naukowe PWN : Warszawa 2013.
- [12] SUDABE S., REZA A., MASAUD M., JAMAL G.: Application of Multi-Attribute Decision-Making Methods in SWOT Analysis of Mine Waste Management. *Resources Policy*, vol. 51, 2017, 67-76.

Ladislav Bartuska - Karel Jerabek - Li Chenguang\*

## DETERMINATION OF TRAFFIC PATTERNS ON URBAN ROADS

*Traffic volume indicates the use and the capacity of road infrastructure. In traffic engineering the traffic volume is generally stated as so-called Annual Average Daily Traffic (abbreviated as AADT), which can be determined from a short-time traffic survey according to the TP 189 methodology. The issue of AADT determination is in fact simplified on the urban roads where we can find types of traffic patterns different from those dealt with in the TP 189 methodology.*

*The introductory part of the paper deals with the theory of determination of traffic volumes and the theory of traffic flow. The aim of the article is to demonstrate traffic patterns on specific urban roads determined by the authors according to the idea that different types of traffic flows on urban roads within the different urban areas may be found. The paper deals with the issue of factors influencing the traffic flows within the city as well.*

**Keywords:** *Traffic Flow, Annual Average Daily Traffic, Traffic Patterns, Constant Time Headway Model, Urban Road Transport Network, Passenger Car Unit.*

### 1. Introduction

The city area itself consists of several multifunctional areas interconnected by transport network. Each city area generates a different number of routes of the transport network users (city residents, employees, etc.). The number and nature of routes are significantly given by the function of the area and the activities of the local population. Moreover, there is transit traffic which is in certain areas of the city involved in the total traffic volume on transit urban roads. City transport system (network) can be therefore considered as a “live” network where the final traffic volumes on the road sections between each city areas are affected by a wide range of factors. In the following lines of the article the authors attempt to outline the issue of traffic flow and define some of the factors influencing the size of the traffic flow on urban roads.

Most methodological tools for calculating resulting traffic volumes on roads from a short-term traffic survey use the road categories and the sets of coefficients which are determined for such road categories (according to the Technical Conditions TP 189) [1]. The methodology is partially based on the German manual HBS (in German: Handbuch für die Bemessung von Strassenverkehrsanlagen) [2]. The methodology contained in TP 189 sets out the coefficients (traffic variations within the day, week and month of a year) which are determined from

long-term measurements conducted on different categories of roads in the Czech Republic. By using these coefficients it is possible to determine Average Annual Daily Traffic volume (AADT), Designed Hourly Volume (DHV) or other determinative traffic engineering outputs. We can determine AADT from short-time traffic measurement according to [1]:

$$RPDI_x = I_m \cdot k_{m,d} \cdot k_{d,t} \cdot k_{t,RPDI}, \quad (1)$$

where:  $RPDI_x$  - Annual Average Daily Traffic to be determined (AADT) [cars/24 hours within day],  $I_m$  - traffic volume of a given type of vehicle identified during the traffic survey [cars/traffic survey duration],  $k_{m,d}$  - conversion coefficient of traffic volume acquired during the survey to daily traffic volume [-],  $k_{d,t}$  - conversion coefficient of daily traffic volume within the day of survey to average daily traffic volume within the week (all seven days in a week) [-],  $k_{t,RPDI}$  - conversion coefficient of weekly average daily traffic volumes to an annual average daily traffic volume [-].

In fact, in relation to urban traffic the sets of conversion coefficients included in TP 189 are set for road categories determined according to the categorization of the Roads Act (transit roads of I., II. or III. class going through the city, urban local roads or urban local roads connecting larger commercial zones) [3]. Especially on urban roads we can determine other

\* <sup>1</sup>Ladislav Bartuska, <sup>1</sup>Karel Jerabek, <sup>2</sup>Li Chenguang

<sup>1</sup>The Institute of Technology and Business in Ceske Budejovice, Faculty of Technology, Department of Transport and Logistics, Czech Republic

<sup>2</sup>North China University of Technology, School of Economics and Management, Business Management Department,

The People's Republic of China

E-mail: bartuska@mail.vstecb.cz

traffic patterns which have significant influence on the final AADT and which are discussed in this paper.

Some methodological approaches are based on functional classification of the area within the city or town (spatial plans) where the area defined by the function is for simplification considered as monofunctional. In the real environment, however, city areas or area categories according to the spatial plan are more or less multifunctional and other factors having a significant influence on the resulting traffic intensity on urban roads should be taken into consideration [4].

## 2. Factors influencing the traffic volumes in urban areas

In general, especially the kind and time of day, weather, events, road works and accidents have an impact on the traffic volume in a given area (or on demand for transport). In the city there is a specific issue, since there is variation of the concentration of travel origins and travel destinations of transport network users – it is necessary to search for factors which more or less affect the traffic flow and its size on a given section of the road within the city.

One of the factors influencing the number of trips in a given area of the city should be the main urban area function (for example, the area function according to the spatial plan). The city is usually divided into individual mono-functional or multi-functional areas.

Traffic solutions and transport services within areas, routing of transport infrastructure and organization of transport systems, technical parameters of communications, capacity of intersections, parking areas and others should be designed in accordance with specific conditions in the urban area. Broader and local relations within the area should be respected and solved at different levels. It is always necessary

to take into account not only the overall structure of the urban area, but also all the specific aspects (present and future) that may have, in the circumstances, an influence on the behavior of transport, namely the volume of generated traffic and modal split of transport [5]. This is essentially a composition and arrangement of individual parts of the urban structure and a varied range of specific factors, mainly qualitative. Some of these potential factors are determined in Table 1 [4].

Taking into account the positive or negative impact of the various conditions of urban areas and other specific factors is an important prerequisite for the proper assessment and design of the effective transport system. It is more than appropriate to consider these factors when determining the final traffic volumes on a given section of urban road in the sense of comparing these volumes to the road infrastructure capacity.

## 3. Traffic flow theory

For the modeling and simulation of traffic flow (traffic stream) on road network sections different models are used, of which the best known are probably the Car Following Model (CFM), the Optimal Velocity Model (OVM), or the Intelligent Driver Model (IDM). These microscopic models reflect reality more accurately than macroscopic stationary models [4].

For the purposes of this article the authors demonstrate the macroscopic approach to the traffic flow theory also known as the constant time headway (CTH) model. When applying this model the idea from the field of traffic safety is considered, i.e. that each reference vehicle keeps a constant distance from the vehicle ahead. Based on this model the characteristics of the traffic flow can be generally determined: velocity  $v$ , density  $k$ , and traffic volume  $q$  (flow).

Potential factors affecting the traffic volumes in relation to urban area

Table 1

| Urban level   | Structure  | Specific factors  |
|---|--|---|
| <ul style="list-style-type: none"> <li>The nature of settlement structure;</li> <li>the position of given area within the settlement structure;</li> <li>area in the central part of the city;</li> <li>area in suburban part of city;</li> <li>catchment area for other part of the city;</li> <li>the microstructure of given area, etc.</li> </ul> | <ul style="list-style-type: none"> <li>The spatial form of the transport system;</li> <li>the spatial arrangement of buildings;</li> <li>terrain configuration;</li> <li>functional layout of area;</li> <li>area accessibility;</li> <li>mono- or multi-functional area;</li> <li>interactions between functional areas;</li> <li>interconnection of transport systems, etc.</li> </ul> | <ul style="list-style-type: none"> <li>The importance and attractiveness given area;</li> <li>attractiveness of the area location for a given function;</li> <li>standard of living;</li> <li>environmental quality;</li> <li>accessibility for pedestrians and cyclists;</li> <li>the distance between related residential and economic areas;</li> <li>quality of public transport services;</li> <li>quality of transport infrastructure (maintenance, safety);</li> <li>car-sharing, bicycle using, , etc.</li> </ul> |

Source: [4]

Density ( $k$ ) is defined as the number of vehicles per unit length of the roadway. Inverse of density is spacing ( $s$ ), which is the center-to-center distance between two vehicles. Traffic volume or flow ( $q$ ) is the number of vehicles passing a reference point per unit of time, vehicles per hour. The inverse of flow is headway ( $h$ ), which is the time that elapses between the  $i$ -th vehicle passing a reference point in space and the  $(i + 1)$ -th vehicle. In congestion,  $h$  remains constant.

We assume that the road capacity (or traffic volume)  $q$  can be expressed as a time period in proportion to the sum of the length of vehicles and the distance between those vehicles. Neglecting the length of the vehicle, the hourly capacity (hourly traffic volume) can be expressed as [6]

$$q = \frac{3600}{h}, \text{ for } h = 2s \text{ it is } q = 1800 \text{ [cars/hour]}. \quad (1)$$

This safety distance is given as time reserve expressing reaction time of the driver. However, in order to have a realistic model it is necessary to take into account the non-zero length of the vehicle together with the length of distance between the two vehicles. The common practice to analyze mixed traffic flow is to convert all vehicles into equivalent numbers of passenger car units (PCUs) which correspond to the PCU length of 4-5 meters [7]. At the speed  $v$  we can describe in simple relation the length (distance) of vehicles [8]

$$d = d_{\min} + vh. \quad (2)$$

Density is subsequently the inverse of vehicle distances according to

$$k(v) = \frac{1}{d_{\min} + vh}. \quad (3)$$

After transferring to the opposite relation velocity dependence on density is obtained according to

$$k(v) = \frac{1}{h} \left( \frac{1}{k} - d_{\min} \right). \quad (4)$$

To express the intensity depending on the density we obtain a linear progression

$$q(k) = v(k) \cdot k = \frac{1}{h} (1 - d_{\min} k). \quad (5)$$

#### 4. Measurements of traffic volumes on specific urban roads

Urban traffic clearly is not a static phenomenon. The authors have dealt with determining traffic patterns typical for selected specific areas within the city. Therefore, the theory of traffic flow is addressed marginally in the next chapters and

outputs from the traffic measurement only refer to traffic flow volumes (intensities).

#### 4.1. Determination of traffic patterns on urban roads

The series of long-term traffic measurement was carried out on the selected roads within the city using the automatic measurement devices Sierzega SR4 - Fig. 1. The traffic volumes collected by the measurement devices Sierzega SR4 vary both in time and in space [9].

For such traffic survey the specific road sections were selected according to the spatial plan of the city, where the city areas are categorized. Only few categories of function areas within the city were selected to demonstrate the outputs in this paper [10]:

Residential area - the urban road within the residential area was selected with the assumption of minimal share of transit traffic.

Commercial area - the driveway to the commercial zone (shopping centers) was selected.

Industry area - the urban road within the industry zone (logistics centers and warehouses, production halls, etc.) was selected with the assumption of minimal share of transit traffic.

Administrative center - the driveway to the administrative center (in this case it was a university campus) was selected.

Traffic survey was conducted continuously for five working days in a week to get relevant data about traffic flow on the selected urban roads. Data were obtained in October 2016 in the city of Ceske Budejovice.



Fig. 1 Sierzega SR4 device mounted on the post of road sign - suitable for long-term measurements (source: Authors)

#### 4.2 Evaluation of the traffic volume measurements

The numbers of vehicles obtained from traffic survey were divided into hourly intervals within all 5 working days and the values were averaged. Traffic flow (and its volume) was divided into both direction to the area and direction from the area to see the differences in daily course of traffic volume. Each hourly interval is expressed as a percentage and represents the share on total average daily traffic volume (100%). This procedure was used for creating the graphs demonstrating the time course of the traffic volumes within the average working day [11].

Daily course (averaged working day) of traffic volumes obtained from the long-term traffic survey on the road section within the residential area is shown in Fig. 2. The selection of the road section for conducting the traffic survey was done due to the fact that there is a minimal share of transit traffic - the maximum number of vehicles should start or/and end in this area. From the following figure it is evident that the function of the area is predominantly residential, thus we can say the hypothesis of minimal transit traffic share is right. The morning peak hour is mostly given by traffic flow heading from the residential area, on the contrary, the afternoon peak hour is given mostly by traffic flow heading to the residential area (residents are coming back to their homes) [12].

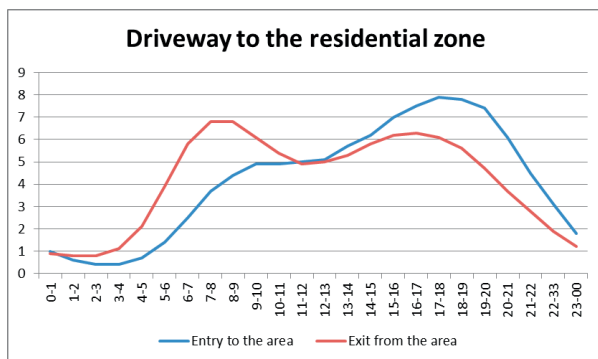

Fig. 2 Daily traffic variations on the road within the residential area - hourly traffic volumes expressed in percentage (source: Authors)

Another selected road section was the driveway to a busy commercial zone. The authors have chosen a commercial zone on the outskirts of the city with plenty of malls and stores and with two driveways only. Daily variations of traffic volumes determined on one of the driveway are shown in Fig. 3.

The infrastructure nearby the shopping centers has mostly the function of access roads. Traffic to shopping centers is associated with their opening hours. Two smooth traffic peaks during a day are generated, on the contrary, in the midnight and early morning hours the traffic is almost none.

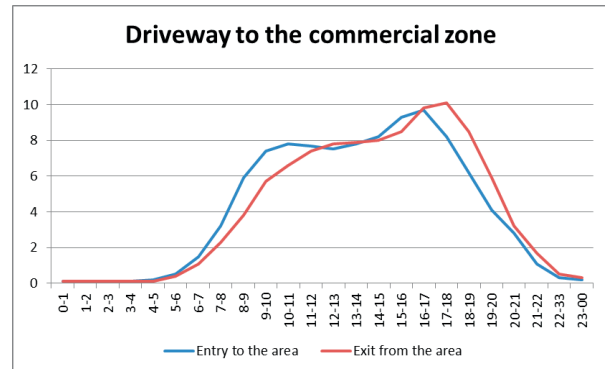

Fig. 3 Daily traffic variations on the road within the commercial area - hourly traffic volumes expressed in percentage (source: Authors)

Figure 4 shows daily variations of traffic volume on the road within the industry area. The road was selected in a nearly homogeneous area with production halls and warehouses only. The transit traffic on the road is insignificant (up to 10%). During evaluation of traffic survey it was necessary to discriminate the category of passenger cars and the category of duty trucks (with maximum permissible laden weight more than 3.5 tons) because the share of heavy vehicles was significant (almost 50% of all counted vehicles).

Again the traffic on the road reflects the local function of the area. It is evident especially on the hourly shares of passenger cars with the maximum numbers of passenger cars being counted near the beginning of every shift in the main production halls and factories in the area.

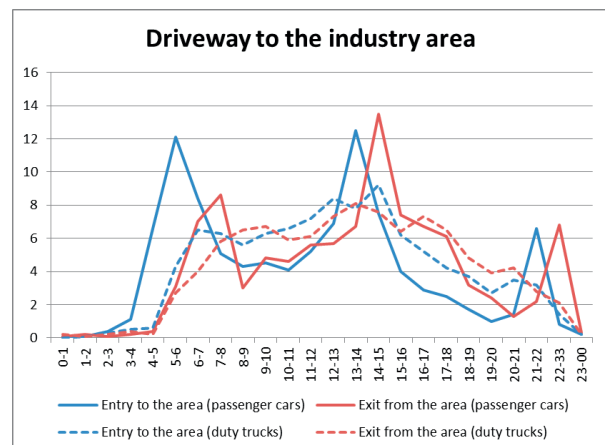

Fig. 4 Daily traffic variations on the road within the industry area - hourly traffic volumes expressed in percentage (source: Authors)

The last selected road section is the driveway to the Institute of Technology and Business in Ceske Budejovice. It is the only access road to the area, where the campus with administrative buildings, auditoriums, library, canteen and dormitories is located. The vast majority of vehicles were

passenger cars and the daily variations of traffic volumes are shown in Fig. 5.

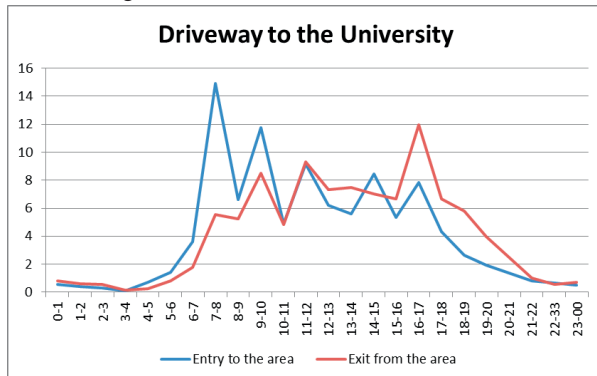

Fig. 5 Daily traffic variations in the University area - hourly traffic volumes expressed in percentage (source: Authors)

## 5. Conclusion

The main objective of the paper was to outline the issue of traffic volume determination, especially the issue of traffic volumes and traffic patterns on the specific urban roads. The authors deal with the theory of traffic flow and evaluate the traffic survey conducted on selected urban roads.

Primary consideration for selecting urban roads for measuring the traffic volume was the fact that roads in the city have different specific traffic pattern (character of traffic) according to the town planning and economic character of the surrounding buildings, for example the daily variations of the traffic intensity will be different for specific urban roads and for the transit fast urban roads with mixed traffic. Daily variation of traffic intensity will also vary with the urban road accessing industrial zones in the city or for urban access roads to schools, student dormitories, administrative institutions etc. We can identify different specific traffic characters (patterns) especially on urban roads, for example [9 and 13]:

- The access roads to shopping centers;
- Urban roads in residential areas;
- Urban roads with administrative centers;
- Fast urban roads;
- Urban roads accessing industrial zones, etc.

When determining the traffic volumes, the methodology according to technical conditions TP 189 is used - The traffic volumes on urban roads are counted from short-time traffic survey according to idea that the traffic flow is the same on a fast urban road within the city as on other urban roads. The important role in the determination of total daily traffic volumes on selected roads has the share of transit traffic. The paper deals with other factors influencing the traffic volumes as well [14 and 15].

The traffic patterns demonstrated in this paper were determined from a short-term traffic survey conducted in the city of Ceske Budejovice by using the automated counting machine Sierzega SR4. The presented traffic patterns are daily traffic variations from Monday to Friday. For detailed conclusions, it is necessary to conduct long-term traffic surveys on which the traffic variations within a week or within the month of a year will be determined. Conducting traffic surveys in other cities of different sizes is also desirable to bring the final determinative conclusions. The authors demonstrated the preliminary outputs of the research of traffic patterns for the purpose of the current methodology update.

## Acknowledgement

The research of traffic flow within the urban areas was partially supported by fund programs National Natural Science Foundation of China (No. 71503011) and Beijing Social Science Foundation of China (No. 16GLC041).

## References

- [1] TP 189 *Determination of Traffic Volumes on Roads* (in Czech), 2<sup>nd</sup> ed., EDIP s.r.o., 2012.
- [2] FGSV (2001) *Handbuch für die Bemessung von Strassenverkehrsanlagen*, Forschungsgesellschaft für Strassen- und Verkehrswesen (in German), FGSV Verlag, Koln.
- [3] Czech Republic - Law No.13 / 1997 Sb., "Road Act" (in Czech), as subsequently amended.
- [4] MARTOLOS, J., SINDELAROVA, V., BARTOS, L., MUZIK, J.: *Methods of Generated Traffic Volume Forecasting* (in Czech), EDIP s.r.o., 2013, ISBN 978-80-87394-08-3.
- [5] BARTUSKA, L., CEJKA, J., CAHA, Z.: *The Application of Mathematical Methods to the Determination of Transport Flows*, Nase More, vol. 62, 91-96, 2015
- [6] HOLCNER, P., MACUR, J., APELTAUER, T.: *Pattern Formation in Traffic Microscopic Model*, *Traffic and Granular Flow 07*, Springer Verlag GmbH, 2007, 249-254, ISBN 3540770739,

- [7] CHANDRA, S., SIKDAR, P. K.: Factors Affecting PCU in Mixed Traffic Situations on Urban Roads, *Road and Transport Research*, vol. 9, No. 3, 2000, ProQuest, pp. 40-50.
- [8] HOLCNER, P.: Safe Distance between Vehicles and Traffic Flow Simulation (in Czech), *Stavebni obzor*, published by Faculty of Civil Engineering, CTU in Prague, VUT, VSB, Praha, No. 8, 2009, 251-255, ISSN 1210-4027.
- [9] BARTUSKA, L., BIBA, V., KAMPF, R.: *Modeling of Daily Traffic Volumes on Urban Roads*. Proc. of ICTTE. City Net Scientific Research Center Ltd. Belgrade, 2016, 900-905. ISBN 978-86-916153-3-8.
- [10] BARTUSKA, L., STOPKA, O., LIZBETIN, J.: *Methodology for Determining the Traffic Volumes on Urban Roads in the Czech Republic*. Proc. of the 19<sup>th</sup> Intern. Scientific Conference on Transport Means, Kaunas: Kaunas University of Technology, 2015, 215-218. ISSN 1822-296X.
- [11] GARBER N., HOEL L.: *Traffic & Highway Engineering - SI Version*, 4<sup>th</sup> ed., Cengage Learning, 2009, p. 129. ISBN 9780495438533.
- [12] OECD, ECMT: *Managing Urban Traffic Congestion*, Summary Document, 2007, 10-25.
- [13] HANZL, J., BARTUSKA, L., ROZHANSKAYA, E., PRUSA, P.: Application of Floyd's Algorithm on Transport Network of South Bohemian Region, *Communications - Scientific Letters of the University of Zilina*, vol. 18, No. 2, 2016, 68-71.
- [14] POLIAK, M., SEMANOVA, S., HERNANDEZ, S., PASTUSZKOVA, E.: Impact of Road Infrastructure Pricing on Transport Planning, *Communications - Scientific Letters of the University of Zilina*, vol. 17, No. 2, 2015, 92-97.
- [15] KOCIANOVA, A.: The Capacity Limits of Roundabouts, *Communications - Scientific Letters of the University of Zilina*, vol. 16, No. 4, 2014, 81-86.

Jaromir Siroky - Stephan Schroder - Jozef Gasparik\*

## COMPARISON OF OPERATIONAL AND ECONOMIC ASPECTS OF DIRECT ROAD TRANSPORT AND CONTINENTAL COMBINED TRANSPORT

*The aim of this paper is to compare economic and operational aspects in the transition from direct road transport to unaccompanied CT using intermodal road semitrailers. A comparison of specifications of transport units was carried out as well as the risk assessment, considering the probability of a critical situation occurrence. Both of these factors are key for the final decision making.*

*As a main part of this research paper, a comparative case study was conducted. For the purposes of this comparison, data from actual transport orders were used on a route starting in the Czech Republic, going through the industrial Northwest of Germany and then to Belgium and the Netherlands.*

*As a result of this research, the direct cost of road transport and CT were compared considering the lifespan of the used equipment. Besides that, the investment cost for a road carrier to enter the CT system was quantified, which is essential for the CT system development.*

**Keywords:** *Intermodal transport, semi-trailer, road transport, economic comparison.*

### 1. Introduction

Intermodal transportation is the term being used to describe the movement of goods in one and the same loading unit or vehicle which uses various modes of transport [1]. It has become an important sector in decreasing transport costs. As the problems in this area are often very complex, the number of intermodal transportation researches has recently increased. A detailed literature survey is reviewed in [2], where authors described the scientific knowledge base. Research [3] is focused on the operational research techniques being applied to support decision making in various modal transfer problems. A scientific papers [4] and [5] analyses the handling technology as well the economic effectiveness of transshipments of good with usage of combined transport.

There are a lot of scientific papers, such as this one, is focused directly on specific case study. This paper deals with transferring a part of road transport to the railway, where the Modal Split is still developing negatively.

To reverse this unfavourable trend, it is necessary to transform a part of road transport into different modes of transport that are more environmentally friendly. The

main aim of purchasing transport units is to support more environmentally friendly types of transport.

Transforming a part of road transport into other, more environmentally friendly modes of transport using combined transport ("CT") creates favourable conditions for reducing the traffic-related environmental burden of the territory. This aim is in line with the general strategy of the Ministry of Transport ("MT") (i.e. mainly to improve the availability of transport services and the quality of infrastructure in the Czech Republic while respecting the principles of sustainable development). MT intends to reduce the negative impacts of transport on the environment and improve the living conditions in the Czech Republic using a motivational tool, i.e. support from public resources (Czech state budget, EU Structural Funds) [6].

The support will predominantly encourage the implementation of those measures that will increase the continental transport using transport units. The support in question will serve as a motivation for the forwarder (carrier, shipper) that has been so far using road transport, to use CT. The potential risk connected with entering a new segment will be offset by the reduction of costs of investment into necessary

\* <sup>1</sup>Jaromir Siroky, <sup>2</sup>Stephan Schroder, <sup>3</sup>Jozef Gasparik

<sup>1</sup>Department of Transport Technology and Control, Jan Perner Transport Faculty, University of Pardubice, Czech Republic

<sup>2</sup>Bahnzentrum Ingenieurburo, Syntrans GmbH, Germany

<sup>3</sup>Department of Railway Transport, Faculty of Operation and Economics of Transport and Communications, University of Zilina, Slovakia

E-mail: jaromir.siroky@upce.cz

technological equipment as continental CT transport units can be used.

The aim of this paper is to compare economic and operational aspects in the transition from direct road transport to unaccompanied CT using intermodal road semitrailers. For the purposes of this comparison, data from actual transport orders were used on a route starting in the Czech Republic, going through the industrial Northwest of Germany and then to Belgium and the Netherlands. The data came from the period between 01/2016 and 05/2016. The comparison was based on actual traffic in identical streams of traffic on the sample route Prague (CZ) -Venlo (NL, B) -Prague (CZ) for direct road traffic; for continental CT, the same route was used with container freight stations in (CZ) CD-DUSS Lovosice and DUSS Duisburg.

The sample transport was performed in direct road transport with a one-man crew; in CT, transport on the first and last miles was performed with a one-man crew as well. The shipping volume was identical; what is only discussed are intermodal road semitrailers in terms of the cost of investment and direct and indirect costs related to the transition from direct road transport to combined transport.

## 2. Comparison of specifications of transport units

For road transport, a regular road semitrailer (SDP 27 ELB) was used; for continental CT, an intermodal road semitrailer (SDP eLHB 3-CS) from the same manufacturer (Krone) was used. The following table contains data relevant for investment decisions in purchasing a transport unit (see Table 1) [7 and 8].

The used transport technology is to meet requirements as to loading capacity, carrying capacity, manipulation in loading and unloading of goods and transport security. The transport units compared meet these basic parameters with the exception of payload; if the SDP eLHB 3-CS semitrailer

is used for direct road transport, the carrying capacity is lower by 2.3%. This difference is caused by the presence of a construction necessary for vertical manipulation, and it is not a limiting factor. The inner loading capacity, construction of closures and load fixing are identical with the road type.

What is a decisive factor is the cost of investment and lifespan of the individual types. As for the lifespan, it can be noted that when renewing the fleet every six years (72 months), this factor is comparable for both modes of transport (for bookkeeping purposes). In comparing the prices of a regular road semitrailer and an intermodal road semitrailer, higher costs of investment are to be expected for the SDP eLHB 3-CS semitrailer. For comparison, prices of investments made in 01/2016 were used. The present value is the same, and therefore the data used is considered sufficiently current, and even the future price development of the semitrailers in question will not be very different. The long-term development of prices is around +/- 3.5% (this variation is related to the demand for intermodal road semitrailers). If the demand increases, the price will likely remain on the current level. Another price element allocated in the investment is the independent tracking unit (T&T). This device is similar to the one used in direct road transport, where it is situated in the vehicle (truck). As we were comparing identical transport operations, the carrier was to maintain the same level of services including on-line transport tracking, and to meet insurance conditions, i.e. to track the goods carried. As can be seen from the comparison of total costs of investment per unit, the SDP eLHB 3-CS semitrailer was more expensive by EUR 2,050, i.e. 8.42%, having comparable lifespan and technical specifications [10 and 11].

## 3. Risk analysis

Another factor in decision making is the risk index for critical situations in CT. We compared the impact rate, having

Comparison of specifications of transport units

Table 1

| Item                                 | Regular road semitrailer<br>(Krone SDP 27 ELB) | Intermodal road semitrailer<br>(Krone SDP eLHB 3-CS) | Difference |
|--------------------------------------|--|--|------------|
| 1 Purchase price [EUR]               | 24,350   | 25,400   | 1,050      |
| 2 Additional equipment T&T [EUR]     | –  | 1,000  | 1,000      |
| 3 Total purchase price [EUR]         | 24,350   | 26,400   | 2,050      |
| 4 Tare weight [kg]                   | 6,400  | 6,980  | 580        |
| 5 Maximum gross weight [kg]          | 36,000   | 39,000   | 3,000      |
| 6 Lifespan [years]                   | 6  | 6  | 0          |
| 7 Loading capacity [m <sup>3</sup> ] | 100  | 100  | 0          |
| 8 Maximum net weight in CT [kg]      | –  | 28,520   | 28,520     |
| 9 Maximum net weight [kg]            | 25,100   | 24,520   | -580       |

Source: Krone, [9], authors

Comparison of risks in performing the SLA

Table 2

| Item   | Regular road semitrailer<br>(Krone SDP 27 ELB) | Intermodal road semitrailer<br>(Krone SDP eLHB 3-CS) |
|--|--|--|
| 1 Risk of accident   | 3  | 2  |
| 2 Capacity of infrastructure                                   | 2  | 4  |
| 3 Impacts in case of (traffic closures, strikes, etc.)         | 2  | 4  |
| 4 Flexibility in extraordinary events                          | 3  | 4  |
| 5 Optimisation and flexibility in selecting (un-)loading sites | 2  | 3  |
| 6 Impacts of transport restrictions                            | 3  | 2  |
| <b>Average risk weight</b>                                     | <b>2.5</b>                                     | <b>3.17</b>  |

Source: [12 and 13], authors

considered the probability of occurrence of the risk 16 (see Table 2). The risk level was established based on key indicators in performing the transport in accordance with the SLA (Service Level Agreement). For comparison, a 1-5 scale was used; 1 being a low risk and 5 being a high risk [12 and 13].

This comparison is a very important factor in decision making. Generally, the risk in CT is by 0.67 point higher. In the future, the risk can be generally eliminated in section 2 (capacity of infrastructure), where an improvement in rail capacity can be foreseen; however, this improvement will occur over a longer period of time. For sections 3 and 4, where the impacts of extraordinary events can be very negative, there is a potential for improvement in the development of continental CT (increasing the number of connections and container

freight stations). The progressing rail liberalisation could also lead to greater flexibility and reliability of rail carriers.

#### 4. Comparison of performance on a sample of transport operations

For the purposes of the comparison, traffic data was used from a sample of transport operations made on the route between Prague (CZ) and Venlo (NL) and back. As a basis, we used the volume of transport performed by direct road transport in comparison with the volume of transport performed by CT in a way that the volume of goods transported was the same for the period between 01/2016

Comparison of performance on a sample of transport operations

Table 3

| Item   | Regular road semitrailer<br>(Krone SDP 27 ELB) | Intermodal road semitrailer<br>(Krone SDP eLHB 3-CS) | Difference |
|--|--|--|------------|
| 1 Sample of transport operations [number]                    | 600  | 599  | -1         |
| 2 Number of units deployed [number]                          | 10   | 18   | 8          |
| 3 Average number of trucks [number]                          | 10   | 4* 6**   | 0          |
| 4 Average number of journeys per unit [number]               | 60   | 31.53  | -28        |
| 5 Kilometres by road [km]                                    | 466,800  | 68,885   | -397,915   |
| 6 Average duration of one order per one unit [hour]          | 48.50  | 71.25  | 22.75      |
| 7 Other non-productive time                                  | 1.5  | 5.50   | 4          |
| 8 Utilisation index (ratio of full and empty kilometres) [%] | 93   | 89   | 4          |
| 9 Number of incidents (accidents, damages)                   | 1  | 3  | 2          |
| 10 Indirect costs (parking fees, etc.) [CZK]                 | 6,000  | 8,000  | 2,000      |
| 11 Number of delays shorter than 2 hours [number]            | 6  | 12   | 6          |
| 12 Number of delays shorter than 5 hours [number]            | 0  | 20   | 20         |
| 13 Number of delays longer than 5 hours [number]             | 0  | 5  | 5          |
| 14 Number of delays longer than 12 hours [number]            | 0  | 15   | 15         |

\* Note: 4 trucks were sufficient mainly for short collections and distributions to/from CT container freight stations in the Czech Republic (fewer kilometres driven); also due to greater quality of services provided by CT container freight stations and longer time windows at customers.

\*\* Note: 6 trucks were deployed due to longer collections and distributions to/from CT container freight stations in Germany (more kilometres driven); also due to lower quality of services provided by CT container freight stations and limited time windows at customers.

Source: [16], authors

and 05/2016. The number of transport operations is a set of operations with a common starting and finishing point – an area close to Prague and Venlo (see Table 3). What was compared was the number of units necessary to perform the same number of transport operations. The difference of one transport operation [6] was caused by the fact that the date of completion was postponed, which has no significant impact on the result of the analysis. In comparing the data, the difference in allowable weights for CT was taken into account. However, the advantage of a greater allowable weight cannot be used very often, and it cannot be relied on for the following reasons [14 and 15]:

1. in case of rail failure, such cargo cannot be transported,
2. the volume of transport with a higher weight varies between destinations,
3. the dual system of shipment dispatching road/rail is problematic for clients.

The comparison of number of units deployed is 10/18 to CT's disadvantage. This is directly related to the average number of journeys made by one unit (approx. 32 for intermodal road semitrailers). This data is very important as it directly influences the amount of investment necessary in the transition from direct road transport to CT. In the following assessment of transit times and economic comparison, a ratio of 10/18 will be considered. This difference between the actual number of units and the number of units technically possible is caused by what has been outlined in the risk analysis, i.e. by the influence of a greater risk of unreliability and seeking solutions in extraordinary events, where it is necessary to increase capacities, reserve spare capacities, etc. For the calculation of economic impacts, we considered a more favourable ratio (1/1.47) (see Table 4). However, this ratio can only be used when there are more units deployed (at least 12 - 15).

The duration of one transport operation and other non-productive times are a limiting factor for the transition to CT for two reasons:

1. profitability of investment is on the side of the carrier,
2. customer's need to increase the volume of goods to ensure the continuity of supplies, i.e. the increase of stocks transported by road.

This aspect was not quantified as the amount of data is not sufficient and its exact allocation would be very problematic. However, it can be said with certainty that the costs of investment increase dramatically as a result of this ratio, i.e. by approximately 70% as compared to road transport.

The comparison also discusses costs related to the stay of semitrailers at container freight stations or parking lots in non-productive times (the number does not express amortisation, but parking fees). Due to a higher number of non-productive hours and higher parking fees, the costs for CT are by approximately 70% higher; however, in absolute terms this

increase is not significant. Nevertheless, it is included in the economic comparison for the sake of objectivity.

The number of trucks necessary was also compared. Due to schedules and related risks, the number of trucks is the same. What is limiting for CT is the necessity to supply goods in a continuous way. This is due to the nature of orders and the transition from road transport that is very competitive in terms of flexibility and speed. In the future, this can be improved by a higher train frequency or schedule optimisation (or a greater capacity provided by train connections) so that non-productive (waiting) times could fall outside of working hours in which customers dispatch or receive goods.

## 5. Comparison of transport cycle duration

For both types of transport, the comparison of transport cycle duration was based on the time of the loading of shipment and time of goods reception, where the working hours of the recipient and dispatcher were the same (see Table 4). Besides that, actual train schedules were considered.

The results provide a clear insight into productive and non-productive times (see Table 4). To a great extent, this sample can be generalised for other CT routes as well.

In CT, the greater share of non-productive times is largely caused by the lower frequency of trains, i.e. by the necessity to park the transport units at container freight stations when waiting for the train connection according to the schedule. This factor probably cannot be offset completely; however, with the increasing number of users and transport units involved in the CT system, it can be assumed that there will be more train connections, i.e. more frequent train departures, and these non-productive times will be partially eliminated. Nevertheless, this ratio will always be significantly higher.

## 6. Comparison of direct costs

The transition to intermodal transport is considered both in terms of increasing costs and savings. These set values are related to a set sample of transport operations, allocated to units with a set time of use of six years (72 months).

The higher costs are mainly generated by the higher purchase price of intermodal road semitrailers; however, the decisive factor is the necessity to purchase a significantly greater number of these specialised semitrailers, than it is the case for direct road transport (at least 12). In terms of savings, road tax relief can be considered; however, there is a significant risk in the event the carrier cannot use the rail even for objective reasons (closures, strikes, etc.). In those cases, the carrier is to pay the tax (or a certain percentage of

Comparison of transport cycle duration per one transport operation

Table 4

| Item      |   | Regular road semitrailer<br>(Krone SDP 27 ELB)<br>[hour] | Intermodal road semitrailer<br>(Krone SDP eLHB 3-CS)<br>[hour] |
|-----------|---|--|--|
| 1         | Time spent loading  | 1.00   | 1.00   |
| 2         | Time spent driving the “first mile”   | –  | 1.50   |
| 3         | Time spent reloading goods at container freight station, waiting for connection | –  | 11.25  |
| 4         | Duration of journey   | 10.75  | 17.00  |
| 5         | Safety breaks   | 9.75   | 0.00   |
| 6         | Time spent reloading goods at container freight station, waiting for connection | –  | 1.00   |
| 7         | Time spent driving the “last mile”  | –  | 1.00   |
| 8         | Time spent unloading  | 1.00   | 1.00   |
| 9         | Time spent driving to loading site  | 1.00   | 1.00   |
| 10        | Time spent loading  | 1.00   | 1.00   |
| 11        | Time spent driving the “first mile”   | –  | 1.00   |
| 12        | Time spent reloading goods at container freight station, waiting for connection | –  | 2.00   |
| 13        | Duration of journey   | 10.75  | 18.00  |
| 14        | Safety breaks   | 9.75   | 0.00   |
| 15        | Time spent reloading goods at container freight station, waiting for connection | –  | 1.00   |
| 16        | Time spent driving the “last mile”  | –  | 1.50   |
| 17        | Time spent unloading  | 1.00   | 1.00   |
| 18        | Average duration of idle time spent in congestions                              | 2.5  | 11.00  |
| <b>19</b> | <b>Total duration of transport</b>  | <b>48.50</b>   | <b>71.25</b>   |
| 20        | Ratio of transport cycle duration   | 1.00   | 1.47   |

Source: [4], authors

Comparison of direct costs of direct road transport and CT for a lifespan of 72 months

Table 5

| Item | Regular road semitrailer<br>(Krone SDP 27 ELB)   | Intermodal road<br>semitrailer (Krone SDP<br>eLHB 3-CS) | Difference    |               |              |
|------|--|---|---------------|---------------|--------------|
|      |  |   | EUR           | %             |              |
| 1    | Purchase price [EUR]   | 24,350  | 26,400        | 2,050         | 8.42         |
| 2    | Indirect costs (parking fees, etc.) [EUR]  | 2,667   | 3,556         | 889           | 33.33        |
| 3    | Road tax [EUR]   | 2,777   | 0             | -2,777        | -100.00      |
| 4    | Servicing costs (tyres, etc.) [EUR]  | 9,500   | 3,500         | -6,000        | -63.16       |
| 5    | Ratio of transport cycle duration  | 1.00  | 1.47          | -0.47         | 47.00        |
| 6    | Actual ratio of transport units, taking into account the risk index                      | 1.00  | 1.74          | -0.74         | 74.00        |
| 7    | <b>Total costs (investment cost ratio)</b>   | <b>39,294</b>   | <b>58,070</b> | <b>18,776</b> | <b>48.00</b> |
| 8    | Indirect conversion costs (operating control, transport management, education, etc.) [%] | 4.50  | 7.00          |               | 2.50         |

Source: [17-22], authors

the tax based on the number of journeys made in CT). Costs related to tyres and servicing can also be saved.

Drawing a general comparison, the cost of investment for a road carrier to enter the CT system is higher by 48% compared to investment in vertically manipulatable units.

From this point of view, the investment support within the Operational Programme Transport is very appropriate. The difficulties of maintaining sustainable operation of CT by a road carrier (i.e. further development, renewal, etc.) are known from previous experience, as in 2009, public support

was granted primarily for the purchase of intermodal road semitrailers (see Table 5).

There is currently no difference between the price of transport on the rail route Lovosice - Duisburg - Lovosice and direct road transport. Distance passed by the road carrier by rail is approximately 650km in one direction. The difference in prices increases with increasing prices of fuels. What can be foreseen is a considerable lack of drivers. This fact can make the decision making easier, albeit only as an indirect factor.

## 7. Conclusion

The values stated above were established for a set of intermodal road semitrailers. For other types of transport units (swapbodies, inland containers), it can be assumed that the conditions of support will be the same as in the case of intermodal semitrailers. The only difference between these two groups of transport units will be their price (Table 5, section 1). However, it can be counted on the same support for the elimination of risk connected with entering a new market segment, i.e. of approximately 40% (Table 5).

For the interest of the whole society, transport policies aim to reduce the environmental burden and damaging of public health caused by road freight transport, by transferring certain transport operations to more environmentally friendly

modes of transport - rail and ship transport. The support will predominantly encourage the implementation of those measures that will increase the continental combined transport using transport units, mainly intermodal semitrailers and swapbodies.

The main aim of public support within this proposed programme is the purchase of transport units for continental combined transport, which is in line with the aims of the European Union, especially the White Paper - Roadmap to a Single European Transport Area - Towards a competitive and resource efficient transport system, i.e. 30% of road freight over 300km should shift to other modes such as rail or waterborne transport by 2030. A similar commitment was implemented in the approved Transport Policy of the Czech Republic for 2014-2020 with the Prospect of 2050. It is also in full accord with the approved Operational Programme Transport for 2014-2020, i.e. the specific objective 1.3 Creation of conditions for a greater use of multimodal transport.

## Acknowledgment

This paper has been supported in connection with the scientific research project of the Technology Agency of the Czech Republic No. TB0500MD004 Proposal of continental combined transport support - loading units“.

## References

- [1] BAHRI, S., HUSEYIN, Y., YASIN, U., GUNERI, A., BAHADIR, G., TURAN, E.: An Approach for Economic Analysis of Intermodal Transportation. *The Scientific World J.*, Article ID 630320, 10 pages, [online], 2014 [cit. 2014-12-14]. Accessible at: <http://dx.doi.org/10.1155/2014/630320>
- [2] BONTEKONING, Y. M., MACHARIS, C., TRIP, J. J.: Is a New Applied Transportation Research Field Emerging? - A Review of Intermodal Rail-Truck Freight Transport Literature. *Transportation Research Part A: Policy and Practice*, vol. 38, 2004, 1-34.
- [3] MACHARIS, C., BONTEKONING, Y. M.: Opportunities for OR in Intermodal Freight Transport Research: A review, *European J. of Operational Research*, 2004, vol. 153, 400-416.
- [4] SIROKY, J., VOHANKOVA, J.: Economic Effectiveness of Operation and Utilization of Large Container Carriers. *Communications - Scientific Letters of the University of Zilina*, vol. 18, No. 2, 2016, 51-56, ISSN 1335-4205.
- [5] SULGAN, M., SOSEDOVA, J.: Rationalization of Internal Transport Operation in the Intermodal Transport Terminal. *Communications - Scientific Letters of the University of Zilina*, vol. 18, No. 2, 2016, 5-10, ISSN 1335-4205.
- [6] NOVAK, J., CEMPIREK, V., NOVAK, I., SIROKY, J.: *Intermodal Transport* (in Czech), University of Pardubice, 2015, 978-80-7395-948-7.
- [7] *Global Logistics for Central Europe*. Metrans [online]. 2013 [cit. 2014-11-16]. <http://www.metrans.eu/>.
- [8] PFEIFFER, P.: *Germany - Public and Special Terminals* (in Czech). Nebezpečný naklad [online]. 2010 [cit. 2015-12-14]. Accessible at: [http://www.nebezpecny.naklad.cz/inc/clanky/1201\\_terminaly.pdf](http://www.nebezpecny.naklad.cz/inc/clanky/1201_terminaly.pdf).
- [9] Deutsche Umschlaggesellschaft Schiene-Strasse mbH. DB Netze [online]. 2014 [cit. 2014-12-14]. Accessible at: [https://www1.deutschebahn.com/ecm2-duss/start/unternehmen/daten\\_fakten.html](https://www1.deutschebahn.com/ecm2-duss/start/unternehmen/daten_fakten.html).
- [10] *Intermodal terminals. Intermodal terminals in Europe* [online]. 2013 [cit. 2014-12-15]. Accessible at: <http://www.intermodal-terminals.eu/database/terminal/view/id/127>

- [11] *Multimodal Transport Systems*, CVUT Transport Faculty [online]. 2014 [cit. 2016-03-31]. Accessible at: <http://www.fd.cvut.cz/projects/k612x1mp/vn.html> .
- [12] Final Report of Project FV355/2012/MOVE/D1/ETU/SI2.659386 Analysis of the EU Combined Transport, KombiConsult GmbH (Frankfurt am Main), Intermodality Ltd (Lewes), PLANCO Consulting GmbH (Essen) a Gruppo CLAS S.p.A. (Milano). [online]. 2016 [cit. 2016-01-20]. Accessible at: <http://ec.europa.eu/transport/themes/strategies/studies/doc/2015-01-freight-logistics-lot2-combined-transport.pdf>.
- [13] APL. Equipment Specifications: Standard Containers [online]. 2015 [cit. 2015-11-15]. Accessible at: [http://www.apl.com/equipment/html/equipment\\_specs\\_standard.html](http://www.apl.com/equipment/html/equipment_specs_standard.html)
- [14] JAGELCAK, J., DAVID, A., ROZEK, P.: *Sea Containers* (in Slovak), EDIS : University of Zilina, 2010. ISBN 978-80-554-0207-9.
- [15] UNCTAD. In United Nations Conference on Trade and Development. Implementation of multimodal transport rules [online]. Geneva: UNCTAD, 2002 [cit. 2011-04-10]. Accessible at: <http://www.unctad.org/en/docs/posdtetlbd2.en.pdf>.
- [16] Public Consultation on Combined Transport: Report on the Contributions Received. [online], 2016 [cit.2016-03-20]. Accessible at: <http://ec.europa.eu/transport/media/consultations/doc/2014-combined-transport/summary.pdf>.
- [17] Sonderrichtlinien - IKV Innovationsforderprogramm Kombiniertes Guterverkehr (1.1.2015 bis 31.12.2020), Herausgegeben vom Bundesministerium für Verkehr, Innovation und Technologie, Wien, [online], 2016 [cit. 2016-05-20]. Accessible at: <https://www.awsg.at/Content.Node/files/kurzinfo/Kombinierter-Gueterverkehr-Merkblatt.pdf> .
- [18] SA.32603 Subsidy scheme “Ferrobonus” for combined transport 2010-2012 and SA.38152 Support scheme for rail transport 2014-2017, [online], 2016 [cit. 2016-04-10]. Accessible at: [http://ec.europa.eu/competition/elojade/isef/case\\_details.cfm?proc\\_code=3\\_SA\\_32603](http://ec.europa.eu/competition/elojade/isef/case_details.cfm?proc_code=3_SA_32603).
- [19] SA.33486 Förderprogramm Umschlaganlagen für den kombinierten Verkehr, Brüssel, 05.08.2011, [online], 2016 [cit. 2016-04-12]. Accessible at: [http://ec.europa.eu/competition/state\\_aid/cases/242238/242238\\_1469822\\_54\\_2.pdf](http://ec.europa.eu/competition/state_aid/cases/242238/242238_1469822_54_2.pdf).
- [20] SA.33993 Aid for the provision of certain combined transport services by rail in Austria 2012-2017, [online], 2016 [cit. 2016-04-10]. Accessible at: [http://ec.europa.eu/competition/elojade/isef/case\\_details.cfm?proc\\_code=3\\_SA\\_33993](http://ec.europa.eu/competition/elojade/isef/case_details.cfm?proc_code=3_SA_33993).
- [21] SA 38152 Support scheme for rail transport (2014/N) - Italy - Emilia Romagna region - aid in favour of rail freight transport, Brüssel, 13.6.2014, [online], 2016 [cit. 2016-05-08]. Accessible at: [http://ec.europa.eu/competition/elojade/isef/case\\_details.cfm?proc\\_code=3\\_SA\\_38152](http://ec.europa.eu/competition/elojade/isef/case_details.cfm?proc_code=3_SA_38152).
- [22] SA.41100 Special Guidelines for the Programme of Aid for Innovative Combined Transport for 2015-2020, [online], 2016 [cit. 2016-05-20]. Accessible at: [http://ec.europa.eu/competition/elojade/isef/case\\_details.cfm?proc\\_code=3\\_SA\\_41100](http://ec.europa.eu/competition/elojade/isef/case_details.cfm?proc_code=3_SA_41100).

Peter Píala – Andrea Galierikova – Andrej David\*

## GLOBAL TRANSPORTATION OF FOODSTUFFS

*Maritime transport belongs to the modes of transportation which ensures intercontinental transport of passengers and cargo between the continents. Not only it is very effective, but it also enables to carry a huge volume of cargo. The transportation of temperature controlled cargo started in the 19th century with the transportation of meat. Until then, transportations of goods under the influence of the temperature were realised only between regions. It is necessary to care about proper handling, cooling, packaging and the compatibility during the transportation of temperature-controlled cargo.*

**Keywords:** Perishable cargo, foodstuffs, cargo packing.

### 1. Introduction

Temperature controlled cargo is the cargo that must be transported at a specific temperature to avoid any damage. Globally, fruit and vegetables are the most dominant types of cargo transported in containers with controlled temperature. Other commodities such as meat, fish and seafood, dairy products, flowers and medicines are transported too [1].

The most important factors for the carriage of the cargo under controlled temperature are:

- regulation of temperature,
- air conditioning,
- humidity,
- proper packaging [2].

### 2. Temperature controlled cargo

Temperature controlled cargo can be divided into these categories:

- pharmaceutical products,
- live animals,
- chemical products,
- flowers and plants,
- foodstuffs:
  - fresh food (e.g. fruit, vegetables),
  - chilled food (e.g. meat, butter, cheese),
  - frozen food (e.g. frozen meat, ice cream) [2].

This article focuses mainly on the last mentioned group of temperature controlled cargo - foodstuffs. Currently, food is

transported mainly for long distances. This transportation is cheap, but also very slow. Therefore, only the transportation of foodstuffs with a long shelf life is realised. The proper handling of goods and right storage is necessary for prevention of cargo damage. It is also important to reduce the time for loading and unloading processes for minimising the delays. This is especially important in the case of handling the refrigerated and frozen foods that perish very quickly. For this reason all the necessary transport documents must be prepared to avoid delays.

Some cargo such as meat must be stored either refrigerated between 0 and -2 °C or frozen at -18° C or lower. Other cargo such as fresh fruit must be stored at temperatures from -3 °C to + 16° C to ensure the goods will arrive in the best condition [3].

### 3. Perishable food

The constant checking of the temperature in the containers and in the holds of the vehicle during the transportation of food is crucial. There are two main factors that influence the durability of the shipment: temperature and relative humidity. For example, vegetable with forced air exchange can lose a certain percentage of water because of the decrease of relative humidity, and it will reflect on a weight. The loss is negligible only in the case of the low-cost products transportation, but during the transportation the products such as coffee, cocoa beans, etc., it is necessary to set the ventilation so as the relative humidity is at the required level.

\* Peter Píala, Andrea Galierikova, Andrej David

Department of Water Transport, Faculty of Operation and Economics of Transport and Communications, University of Zilina, Slovakia  
E-mail: peter.piala@fpedas.uniza.sk

### 3.1 Cargo refrigerating during the transport

Perishable cargo must be cooled to the specific temperature before the loading due to avoiding damage of cargo as a result of too long refrigeration of the cargo space. The bananas and citrus fruits which do not perish quickly may be cooled in the cargo space.

Figure 1 presents a model situation - citrus fruit in carton boxes placed on pallets. This fruit was transported to a warehouse with temperature 23 - 25 °C. The required temperature of fruit is 4 to -5°C. The temperature of air in the warehouse was stabilised after 48 hours, but the temperature of the fruit surface stabilised after 127 hours. The temperature of the fruit depends on the location of carton boxes on the pallet [4].

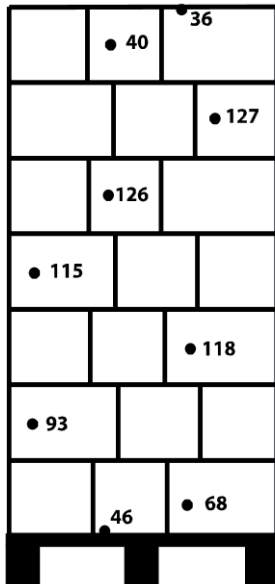

Fig. 1 The time in hours required for the cooling of the individual layers of citrus fruit packed in cartons and placed on pallets.

Source: [4]

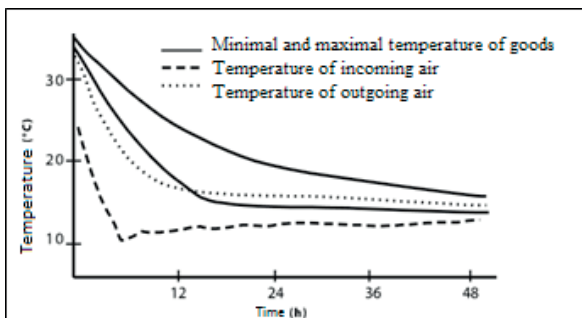

Fig. 2 Cooling bananas

Source: [4]

The cooling device can refrigerate the bananas during the transportation to the required temperature (13 to 14 °C) very quickly [4]. Figure 2 presents the cooling process of bananas.

#### Fresh fruit and vegetables stored on pallets (cartons on pallets)

The air always flows by the path of the least resistance. During the loading cargo into the container, there must be gaps or “chimneys” for ensuring better air circulation throughout the cargo. The air that does not pass through cargo cannot adequately remove the heat produced in the respiratory processes.

If the cargo does not cover the whole T-floor, some type of filling material must be used. This material must be placed on the places where is stored no cargo. The correct placing of goods ensures air flow in the space and makes air circulating throughout the cargo to ensure proper air flow. The cargo should always be placed a few millimetres from the wall of the container to ensure the lateral air flow [5 - 7]. Figure 3 shows the deployment of cargo and airflow between the cargo in the container.

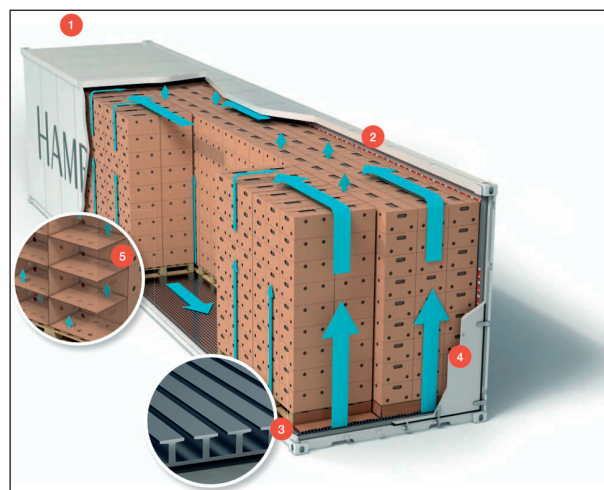

Fig. 3 The deployment of cargo in the container

Source: [5]

Figure description:

1. Cooling unit.
2. The maximal height - the height cannot exceed red line that presents the maximal allowed height of the cargo. This line provides adequate space for air circulation over the stored [cargo].
3. T-floor - the most common form of the floor is known as the T-floor (T-shaped cross section, which forms the floor).
4. Doors.
5. Airflow - arrows show the flow of air inside the reefer containers.

### 3.2 Cargo packing

Packaging is an important step for sustaining the quality of the foodstuffs. Important packaging factors are:

- ventilation,
- protection agents (from contamination, abuse and dehydration)
- strength,
- insulation,
- marking [5 and 8].

Packaging facilitates the handling and distribution. Labels on packages can be a powerful marketing tool (design, colour, etc.). There are two types of packages:

1. Inner packaging - direct contact with the product.
2. The outer packaging - normally contains a number of inner packaging.

Requirements for internal packaging of refrigerated and frozen products are different from fruit and vegetables. The most important characteristics of packaging materials used for refrigerated or frozen products are:

- water vapour permeability,
- gas permeability,
- physical properties.

Figure 4 presents airflow between cartoons on the pallet.

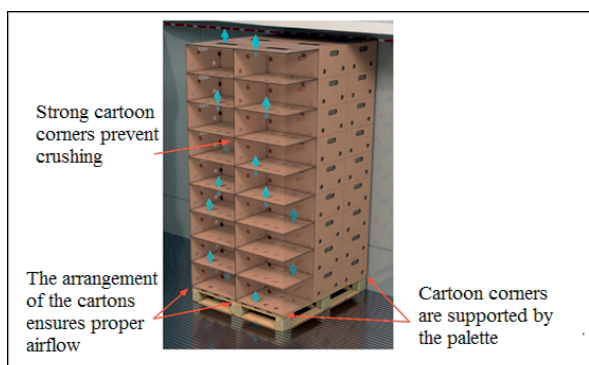

Fig. 4 Airflow between cargos on the pallet  
Source: [5]

- Packaging must withstand:
- rough handling,
  - compression of the accumulated weight of stacked packages,
  - shocks and vibrations during the transportation,
  - high humidity during cooling, transportation and storage.

Cartons for fresh fruit and vegetables require airflow by the gaps at the top and bottom of the boxes. The properties such as: quantity, location, size and shape of the air gaps depend on the product. The wax-impregnated cardboard or other materials that do not lose power in a high humidity environment should be used. The strength of the carton is in its corners. Stacking boxes directly to each other, it is recommended and ensures minimising of crushing cartons [5 and 9].

### 4. Recommended transport conditions and the approximate shelf life of refrigerated cargo

The following Table 1 shows the recommended settings (temperature, ventilation and dehumidification) and approximate shelf life for products transported and stored in standard freezer containers [2 and 10].

### 5. Foodstuffs compatibility

Table 2 shows food that can be or cannot be transported together in one and the same container or stored in the same room. For example, unripe bananas or potatoes cannot be transported or stored with another food. Conversely, asparagus can be transported or stored together with apples, apricots and kiwi [2 and 10].

### 6. Conclusion

In the paper we have focused on temperature-controlled cargo and its division into the categories. There is need to

Recommended settings [2]

Table 1

| Cargo       | Temperature (°C) | Ventilation m3/h | Relative humidity (%) | Dehumidification On/OFF | Approximate shelf life after harvest |
|-------------|------------------|------------------|-----------------------|-------------------------|--------------------------------------|
| Apples      | -1 to +4         | 10 - 60          | 90 - 95               | OFF                     | 1 to 7 months                        |
| Avocado     | +4 to +13        | 30 - 60          | 85 - 95               | OFF                     | 2 to 3 weeks                         |
| Bananas     | +13 to 14.4      | 25 - 60          | 90 - 95               | OFF                     | 18 to 22 days                        |
| Blueberries | -1 to 0          | 0 - 10           | 90 - 95               | OFF                     | 10 to 14 days                        |
| Carrot      | 0 to +2          | 10 - 20          | 90 - 98               | OFF                     | 1 to 9 months                        |

Foodstuffs compatibility

Table 2 [2]

|                | Apples | Apricot | Asparagus | Eggplant | Banana (unripe) | Bean   | Fennel | Kiwi (unripe) | Potatoes |
|----------------|--------|---------|-----------|----------|-----------------|--------|--------|---------------|----------|
| Apples         | Yellow | Green   | Green     | Red      | Red             | Red    | Green  | Red           | Red      |
| Apricot        | Green  | Yellow  | Green     | Red      | Red             | Red    | Green  | Red           | Red      |
| Asparagus      | Green  | Green   | Yellow    | Red      | Red             | Red    | Red    | Green         | Red      |
| Eggplant       | Red    | Red     | Red       | Yellow   | Red             | Green  | Red    | Red           | Red      |
| Banana(unripe) | Red    | Red     | Red       | Red      | Yellow          | Red    | Red    | Red           | Red      |
| Bean           | Red    | Red     | Red       | Green    | Red             | Yellow | Red    | Red           | Red      |
| Fennel         | Green  | Green   | Red       | Red      | Red             | Red    | Yellow | Red           | Red      |
| Kiwi (unripe)  | Red    | Red     | Green     | Red      | Red             | Red    | Red    | Yellow        | Red      |
| Potatoes       | Red    | Red     | Red       | Red      | Red             | Red    | Red    | Red           | Yellow   |

follow the rules to avoid the damage of temperature-controlled cargo during the transport and handling operations. The proper cooling, packaging and compatibility of each type of cargo were mentioned in the paper. Ignoring the rules can cause the cargo damage and thus lead to large financial

losses. We have also focused on foodstuffs compatibility that defines which types of cargo can be transported together, or not. This compatibility is influenced by chemical attributes of transported cargo.

## References

- [1] *Review of Maritime Transport 2015*. online: [http://unctad.org/en/PublicationsLibrary/rmt2015\\_en.pdf](http://unctad.org/en/PublicationsLibrary/rmt2015_en.pdf), 09 November 2016.
- [2] *SIR-C*. online: [www.sir-c.se/getfile.ashx?cid=257832&cc=3&refid=2](http://www.sir-c.se/getfile.ashx?cid=257832&cc=3&refid=2), 06 November 2016
- [3] *Refrigerated and insulated containers - Transport Information Service*. Online: [http://www.tis-gdv.de/tis\\_e/containe/arten/kuehlcon/kuehlcon.htm](http://www.tis-gdv.de/tis_e/containe/arten/kuehlcon/kuehlcon.htm). 01 November 2016.
- [4] ZAJAC, P., CAPLA, J., GOLIAN, J., BELEJ, L.: *Hygiene Distribution and Sale of Food* (in Slovak), Slovak University of Agriculture, 2013, ISBN 978-80-552-0970-8.
- [5] *Reefer guide*, online: [http://www.hamburg-sued.com/group/media/sharedmedia/dokumente/brochures/Reefer\\_guide.pdf](http://www.hamburg-sued.com/group/media/sharedmedia/dokumente/brochures/Reefer_guide.pdf), 20 November 2016.
- [6] ZALEZAK, M.: *Technology in Ports and Transshipment Areas, 8 - Container Terminals*, EDIS : University of Zilina, 2001, ISBN 80-7100-867-2.
- [7] RODRIGUE, J.-P., COMTOIS, C., SLACK, B.: *The Geography of Transport Systems, 3<sup>rd</sup> ed.*, 2013, 411 p., ISBN 978-0-415-82253-4.
- [8] SULGAN, M., SOSEDOVA, J.: Procurement of Materials and Components for Manufacturing Activity, *Communications - Scientific Letters of the University of Zilina*, vol. 16, No. 2, 2014, 58-62, ISSN 1335-4205.
- [9] STOPFORD, M.: *Maritime Economics*, Routledge : Oxon 2009, 816 p., ISBN 978-0-415-27558-3.
- [10] PIALA, P., DAVID, A.: Transport of Tropical Fruits to Central Europe, *Our Sea*, vol. 63, No. 2, 2016, 62-65, ISSN 0469-6255.

Milos Poliak - Lenka Komackova - Salvador Hernandez - Marek Jaskiewicz - Gabriela Boldizarova\*

## SOURCES OF FINANCING PUBLIC PASSENGER TRANSPORT SERVICES

*The paper deals with the financing of public passenger transport. It analyses unconventional types of financing public passenger transport abroad. The aim of the paper is to present the methodology of creating funding sources for the financing of public passenger transport which is applicable in the Slovak Republic and in the member states of the European Union. The key idea of the methodology is to use funding sources arising from the provision of public services.*

**Keywords:** Transport, passenger transport, financing, source, acquisition, transport service.

### 1. Introduction

Public passenger transport is one of many important elements of the socio - economic environment in which the public passenger transport operates. Public passenger transport is characterised as a public service. Its main task is to satisfy transport requirements, e.g. transport to work, school, hospital, offices, etc. To a great extent, the service is provided by bus service and railway transport of the Slovak Republic. Suburban bus service, regional rail services and city transport play an important role in the transport services of conurbations.

It is necessary to spend considerable funds for right and quality operation of public passenger transport. The state has an obligation to provide transport services in its whole territory even if the services are not cost - effective.

Providers use their own public budgets to cover the financial losses. In the USA, financing from public sources covers from 57 to 89% of operating costs in bus service while in railway transport it covers from 29 to 89% of operating costs [1]. In the EU, financing from public budgets covers from 23 to 50% of operating costs [2 and 3], depending on the system of financing in the particular state of the EU. In general, it is not possible to finance public passenger transport only from transport revenues and advertising revenues. This statement is supported by studies that were elaborated before

1990, e.g. Bly et al. [2] or Pucher and Markstedt [4]. The situation in the Slovak Republic is the same as in other European countries. The public passenger transport is funded from public budgets but these sources are not sufficient. The aim of this paper is to identify unconventional ways of the financing of transport services.

### 2. The current way of financing transport services

The financing of public services in public passenger transport is covered by the Regulation (EC) No 1370/2007 on public passenger transport services by rail and by road, which defines the method whereby a contracting authority provides public services in public passenger transport. The aim of this Regulation is to achieve a greater number of services, the increase of road safety and the quality of provided services with the lowest possible costs. The Regulation specifies conditions which have to be respected by contracting authorities when ordering transport services which are funded from public sources. The amount paid from public sources cannot exceed the net financial impact, which is the sum of positive or negative impacts of compliance with obligations resulting from public services on expenses or revenues of a public services provider.

\* <sup>1</sup>Milos Poliak, <sup>1</sup>Lenka Komackova, <sup>2</sup>Salvador Hernandez, <sup>3</sup>Marek Jaskiewicz, <sup>4</sup>Gabriela Boldizarova

<sup>1</sup>Department of Road and Urban Transport, Faculty of Operation and Economics of Transport and Communications, University of Zilina, Slovakia

<sup>2</sup>School of Civil and Construction Engineering, Oregon State University, Corvallis, Oregon, USA

<sup>3</sup>Department of Automotive Vehicles and Transportation, Faculty of Mechatronics and Machine Engineering, Kielce University of Technology, Poland

<sup>4</sup>The Institute of Lifelong Learning, University of Zilina, Slovakia

E-mail: lenka.komackova@fpedas.uniza.sk

## 2.1 The Slovak Republic

The funding of transport services is divided among three contracting authorities in the Slovak Republic. Municipalities are contracting authorities for transport services in the area of the town which are funded from the town budget. Regional bus service is provided by autonomous regional administration which does not have any appropriations committed to this purpose but it finances transport services directly from the regional budget. The rail transport service is provided by the state administration – the Ministry of Transport, Construction and Regional development of the Slovak Republic which finances transport services from its resources in the state budget. The Slovak Republic has no model which would define any fees or taxes as a source of transport service funding.

## 2.2 Belgium

In Belgium, the federal state is responsible for rail transport. Regional governments are responsible for other public transports such as bus service, tramways and underground. The state finances rail transport. In the case of an increased interest of regional governments in some investment projects in rail transport they may co-finance these projects. Other types of public transport are financed by regional and local governments.

The main source of funding for both the state and autonomies are tax revenues. Resources in rail transport come from the tax revenue from the state budget. Public transport in towns is a part of regional transport [5].

## 2.3 The Czech Republic

In 2005, the rationalisation of responsibility for public services was finished in the Czech Republic. Since 2005, the public services have been provided by three levels of contracting authorities:

- Regions or providers of public services authorised by regions are responsible for providing transport services in their territorial districts. They order regional public rail services, i.e. Sp trains and OS trains (regional express and passenger trains), and municipal bus services.
- Towns may order lines of city transport.
- The Ministry of Transport orders national trains, i.e. R trains, Ex trains and EC trains (fast train, Express and EuroCity) to provide connection between main conurbations of the Czech Republic.

Transport services in the Czech Republic are also provided by commercial services. Coach transport, international bus

transport and long distance rail transport are mostly operated on commercial basis.

Regions are given committed subsidies for providing public transport services by rail transport. The Ministry of Transport provides transport services in passenger transport by public rail transport on the basis of the contract of public services with Ceske drahy, a. s. (JSC) The transport services funding is mainly obtained from the state budget which is formed of general tax revenues. The public resources bound to public transport are divided according to the percentage among the contracting authorities – The Ministry of Transport, autonomous regions and towns [6].

## 2.4 Denmark

The rail transport in Denmark is funded from the Danish government budget and from the fare revenues. The bus service is funded in a similar way. It is not funded by the state but by local autonomous regions and from the fare revenues. In general, the contribution of the state subsidies in transport covers one half of the costs and the other half is covered by the passenger revenues. City transport consists mainly of bus service which is funded by respective cities. Resources for public transport services funding are obtained from tax revenues [5].

## 2.5 Estonia

Rail transport in Estonia, both regional and long distance, is funded by the state which also funds suburban bus service to a great extent. About 70% of costs in rail transport are covered from public funding. In regional bus service it is about 60% of total costs which are funded by the state. City transport including tramways and trolleybuses is funded by towns. Long distance bus service and all international services are operated on the commercial basis, which means they are funded by the fare revenues. The sources of financing which are not covered by the fare revenues are obtained from the general tax revenues. The operation of city transport is funded by cities. The state can contribute to funding in the case of significant investment projects like the renovation of tramways or the modernisation of the fleet in Tallinn [5].

## 2.6 Ireland

In Ireland, the National Transport Authority subsidises public passenger transport. The state funds everyday bus and rail operation which cannot be procured on commercial basis.

Resources for public bus service operation and rail transport operation mainly consist of the fare revenues and the state subsidies [5].

## 2.7 Iceland

The bus service in Iceland is divided into two parts: urban and suburban. The bus system in Reykjavik is financially supported by state subsidies because of the underdeveloped infrastructure for cars resulting from the Icelandic transport plan. The amount covers about a quarter of the total costs. Another quarter of the costs is covered by the passenger revenues and the remaining part is formed by the finances from local governments (town budgets and adjacent urban regions) [5].

In suburban regions, the bus system is partially funded by state subsidies. The other part comes from the local autonomous regions. As in most countries, the state subsidies are obtained from tax revenues, however, in Iceland they are obtained directly from driving fuel taxes.

Iceland has no rail transport because there is no railway infrastructure. As a result, the population in Iceland very often uses domestic flights in a similar way as most people in the European Union use railway lines for distances over 350 kilometres. Domestic flights to some distant areas are subsidised according to the selection procedure.

## 2.8 Lithuania

In Lithuania, there are two ways of providing resources for public passenger transport. The first is funds from the whole state budget or local autonomous regions. The second way are the structural funds of the European Union.

The state and the structural funds of the European Union support the public railway transport. The bus transport is funded by local autonomous regions and the structural funds of the European Union [5].

## 2.9 Austria

According to the act on local and regional public passenger transport, two public authorities are responsible for managing and financing of public transport:

- Federal bureau is responsible for basic services in local and regional public railway transport;
- Regional or local administrative bodies are responsible for planning of demand-oriented services.

That is the reason why railway transport lies within the area of responsibility of the federal government and provincial

governments unlike the bus transport which is provided by provincial governments and towns.

Federal bureaus obtain resources for public passenger transport financing from the federal budget which is formed by tax fees. Provinces and towns finance public passenger transport from their budgets to the extent possible. There are also contracts between provinces and federal autonomous regions which are aimed at the co-financing of agreed services with the federal government (e. g. special tariffs for students, total free fare for pupils and students). At the municipal level, there are some taxes and fees in order to fund public transport, e. g. in Vienna, the local administrative body increased taxes for companies to fund the operation of the underground.

In Austria, city transport is financed from city budgets and from the resources of the Transport Association of which cities must be a member. Subsequently, in compliance with territorial and price levels they receive grants [5].

## 2.10 Switzerland

In Switzerland, resources for the financing of transport services are from different sources. The most important incomes are: mineral oils tax (50% of the tax is for transport), excess tax from motor fuels, and non-specific subsidies the origin of which is not specified. Resources are offered to different institutions, e.g. to the Public Passenger Transport Fund or the Infrastructure Fund, which then allocate the resources for a particular purpose (public passenger transport expenses, significant railway projects, etc.). City transport is mostly financed from city budgets [5].

## 3. Unconventional ways of financing of transport services

Based on the analysis of conditions in the selected states, it is possible to say that it is necessary to finance public passenger transport from other sources than the revenues from transport. Mostly, the transport services are funded from public budgets but in many states, the funding of public passenger transport is costly. Apart from traditional sources of financing it is possible to consider unconventional ways of funding. In the case of these sources a certain share of taxes or fees is bound to the transport services funding. In the following part, there are identified ways of unconventional transport services financing.

### 3.1 Employee tax and employer tax

Employer taxes and local income taxes are usually collected by national and local governments around the world but there are some cities in which the taxes are closely linked to payments to the public passenger transport systems. In the United States and Europe, local payroll taxes are used for public passenger transport (e. g. in the United States in Portland and Eugene, Oregon). Oregon permitted local transport authorities to use payroll taxes for generating the revenue. Louisville and Cincinnati use local income taxes to subsidise public passenger transport.

In Europe, employer taxes as a source of financing for transport service are applied in France. The first tax collecting was in Paris in 1971 and later it extended to smaller provincial towns [7]. The tax has to be paid by companies with more than nine employees unless they live in a company precinct or companies provide them with their own transport. A similar way of financing is used with the underground in Vienna [8].

### 3.2 Taxes linked to property

A part of the nature of property tax lies in the concept of providing public passenger transport which brings an advantage to property users (in this case the increase of the property value) [9]. This mechanism is defined as a mechanism which makes authorities responsible for the development of the city transport infrastructure and allows them to obtain a part of financial benefits from land developers or society. This advantage is reflected in the rise of the real property value which can be considered as a complex index of all advantages formed by development, including better availability and the increase of business opportunities. This "recuperation of value" process is divided into taxes and single or irregular developer fees. The tax can be defined as a regular property payment and continuous amounts to a local or regional government which later allocates subsidies for public passenger transport. Paying for providing public services by the property (or the land) is a common practice in the world and can be observed in the whole of Europe, Asia and North America. However, in most cases, the resources are collected by authorities and then allocated to each sector according to the actual political purposes. In North America, nevertheless, the allocation of property taxes to fund public transport is common in cities like Minneapolis, New York, Denver, Detroit, Miami, Los Angeles, San Francisco and Vancouver [10 - 11]. Examples of the allocation of property taxes outside North America are rare but can be found in Japan (Osaka), India (Mumbai) and Spain (Barcelona).

### 3.3 Development fees

The reaching of the value is not necessarily limited to property taxes because the development fees can be implemented. Sims and Berry [12] state that the collected value from specific taxes and charges comprises:

- Development fees - a part of transport costs would be reclaimed by special fees for various uses of the land usually charged in the time of a new development of the property in lucrative areas.
- Advantages sharing is bound to the property value increase resulting from public investments.
- Density bonusing, near public transport stations whereby the participation in a programme is voluntary. Developers can choose if they participate or not. They will get some extra "density" or extra permissions to build but they have to pay for them. A similar kind of scheme is tendering or auction of "density" where a fixed value of density is put into the auction.
- Connection fee, whereby the owner of the property pays a specific fee for a direct connection with a transport system.

Examples of implementation in real life of these kinds of schemes are known around the world. Many of them can be found in North America, e. g. San Francisco, Washington and Portland. In Europe, development fees are used in Hamburg, Germany. Common development programmes began in Hong Kong and Japan [8].

### 3.4 Parking charges and fines

Parking charges are a common part of our life and they are used by local authorities to finance their activities [13 and 14]. Charges in general cannot be perceived as an unconventional mechanism. However, these charges are rarely hypothecated to support public passenger transport or as a part of a planned transport financing package. There are clear examples in England. In Milton Keynes, revenues of parking charges are dedicated to support public passenger transport which is a part of transport and parking strategy. The example points at the potential of these charges linked to environmental and transport planning processes. There is another program implemented at the Heathrow, Stansted and Gatwick airports where passengers contribute an average € 0.31 from every parking transaction to support public passenger transport. In Amsterdam, revenues from central city parking are used for partial financing of a new traction line. Similar implementations can be found in the world, e. g. Aspen (Colorado), Miami (Florida), La Spezia, Verona and Milan in Italy [8].

### 3.5 Fees for using road space

The idea of collecting fees for using roads is one of the oldest. Already at the end of 17th century and at the beginning of 18th centuries, many of roads in the U.S.A. were built as private toll roads. Recently, a toll road has become interesting again, especially in the European Union. One of more traditional reasons is to generate revenue for the construction of new roads. The second and newer reason is to correct traffic congestion and air pollution but the revenues can also be used to support public passenger transport. Although charging of roads (and congestions) is not widely implemented, there is some experience where revenues are transferred to finance public passenger transport.

The city roads toll in Europe is a phenomenon of Scandinavian countries [7]. The toll in Bergen (first time used in 1986), Oslo (1990) and Trondheim is a “cordon system”. The vehicles (public transport vehicles are free) pay for the entrance to the centre of city and revenues are used for the financing of road investments and public passenger transport investments. The toll is also common in the United States but it is often linked to the use of bridges and tunnels. Some of the toll revenues can be hypothecated to public passenger transport. In San Francisco, Golden Gate Bridge tolls are used for supporting inter-county transport services including buses and ferries. In New York and Philadelphia, bridge toll and tunnel toll are important financial sources as well. These examples were aimed at the increase of revenues but there are implemented programmes aimed at the reducing of congestions. Congestion fees have been collected in Singapore since 1975 (Small and Gómez-Ibáñez, 1998). Some of the fees from Area License Scheme (ALS - congestion toll in Singapore) are to improve public transport as a substitute for car transport. A similar scheme is used on the highway (international I-15) near San Diego. In this scheme, users can choose the congestion lanes or to pay for the congestion free lanes. This kind of fee depends on the level of congestion on the highway. The revenues are partly used to finance express bus services in the corridor I-15 [8].

### 3.6 Local motoring taxes

A local motoring tax is a tax collected from drivers by local jurisdiction for local purposes (one of them is public passenger transport). It is collected in addition to the state and federal fuel tax. Motor vehicle taxing is common all over the world (taxes are usually collected nationally) but the revenues are rarely directly allocated (on a local basis) to finance specific objectives. Local motoring taxes may have different forms and they are relatively common in the United States, mainly fuel tax and excise tax.

There are two types of local fuel taxes in Florida - a gas tax approved by voters and a fuel tax approved by the authorities. A local motor vehicle excise tax has been implemented in Washington. It is an annual excise tax on the fair market value of the vehicle. Towns and districts may direct half of the tax revenues for public passenger transport needs. In St. Clara (California), the fuel tax is used to finance the local contribution to the light railway in San Jose [11].

Other examples out the United States are not very known although there are some programmes implemented in Canada as well (e. g. Vancouver, Montreal). In Lisbon (Portugal), public transport is financed from the fees on diesel oil. Since 1967 there has been taxation in Germany allocating €0.026 from one litre of the sold fuel for investments in city roads and public transport [8].

### 3.7 Consumption tax

In general, the consumption tax is a tax imposed on consumer goods such as general goods, specific services and luxury items and energies (e.g. gas). The consumption taxes may bring dedicated finance resources to transport authorities and through their implementation the authorities may collect revenues for operating and capital costs. Transport agencies often use taxes to compensate for the decreasing state grants, to build significant investment projects or to supplement operating revenue. This kind of taxes is common in the United States.

The consumption tax in the most states in the U.S.A. has the value of 0.5% from the value of the goods but it represents a great part of the operation of public passenger transport funding. In some towns, the tax is applicable to any sold goods and the collected tax is used to support transport. These kinds of taxes are implemented in Denver, New Orleans, Atlanta, Reno, Fort Worth, Austin and San Francisco [15]. Outside the United States, this system of obtaining funds to finance public transport is found in India.

Apart from consumption taxes in the United States, there are also gambling taxes used for financing public passenger transport. The part of revenues from lotteries is assigned for public transport. However, in general, lotteries are perceived as a controversial source of revenue. Critics point at the negatives of gambling - there is a chance for corruption and a high participation rate of poor people. This kind of tax system exists in Maricopa County (Arizona) and in Pennsylvania [8].

### 3.8 Cross-utility financing

Cross-utility financing does not necessarily have to be an unconventional mechanism regarding its extensive application

in the parts of Europe, North America and elsewhere. There are two types of cross-utility financing in practice. The first is the fee (tax) for the use of a (public) service similar to the sales tax and employer tax. In the other type, a public transport department that makes a loss is cross-financed by a profitable department of public services. The revenue depends on outside factors, such as economic conditions and social trends.

The first type was found in Pullman, Washington. The transport in Pullman is paid for by a 2% charge on telephone, water and sewage (the city is the owner), electricity, gas and the fee for the rubbish. The companies which offer these services collect the tax. Then, the tax is forwarded to Pullman and then to the transport department. The taxes cover 40% of operational costs of fourteen town's vehicles, road services and para-transit services. Other examples are found in Springfield, Missouri and New Orleans where the fee from the electricity sales is used to finance public transport.

There is cross-financing system in Europe as well. In Germany (e. g. Wuppertal), systems of public transport are local departments and as such they are often subsidised from revenues of other town's departments like water, gas and electricity that make excess profit. This fact allows the town to compensate for the losses in transport with any revenues, which means that these revenues are not subject to corporation tax. Similar conditions have been adopted in some Italian (Milan) and Austrian cities and in Luxembourg.

#### 4. Conclusion

Nowadays, contracting authorities use financial resources from their own budgets which are necessary for the compensation of provable financial loss which arises from the operation of transport services. The amount of their budgets is limited and there are no specific sources dedicated to the financing of public passenger transport.

It is not possible to create a bigger source of financing by increasing the fares. According to the price elasticity of demand, the increasing of the fare would motivate passengers to change their means of transport. Nowadays, the Slovak Republic plans to build integrated transport systems which would attract passengers to travel by public passenger transport, and which would represent a tool for increasing the road safety. However, the building of integrated transport systems requires a higher financial support from public sources. That is the reason why it is important to identify new ways of obtaining resources from other sources.

#### Acknowledgement

This paper was supported by "Agentura na podporu vyskumu a vyvoja" based on the Contract No. SK-PL-2015-0019.

#### References

- [1] PARRY, I. W. H., SMALL, K. A.: Should Urban Transit Subsidies Be Reduced? *American Economic Review*, vol. 99, No. 3, 2009, 700-724.
- [2] BLY, P. H., WEBSTER, F. V., POUNDS, S.: Effects of Subsidies on Urban Public Transport. *Transportation*, vol. 9, No. 4, 1980, 311-331.
- [3] BUEHLER, R., PUCHER, J.: Sustainable Transport in Freiburg: Lessons from Germany's Environmental Capital. *Intern. J. of Sustainable Transportation*, vol. 5, No. 1, 2011a, 4370.
- [4] PUCHER, J., MARKSTEDT, A.: Consequences of Public Ownership and Subsidies for Mass Transit: Evidence from Case Studies and Regression Analysis. *Transportation*, vol. 11, No. 4, 323-345.
- [5] VARJAN, P.: *The Proposal of the Methodology of the Funding Sources in Public Passenger Transport*, dissertation thesis, adviser: doc. Milos Poliak, Zilinska univerzita.
- [6] POLIAK, M.: The Relationship between the Fair Profit and Risk in the Public Passenger Transport in the Slovak Republic, *Ekonomicky casopis/J. of Economics*, vol. 61, No. 2, 2013, 206-220.
- [7] FARRELL, S.: *Financing European Transport Infrastructure: Policies and Practice in Western Europe*, London: Macmillan. ISBN 033-37-189-68.
- [8] UBBELS, B., NIJKAMP, P.: Unconventional Funding of Urban Public Transport. *Transportation Research*, Part D, 7, No. 1, 317-329, 2002.
- [9] NEDELIAKOVA, E., SEKULOVA, J., NEDELIAK, I., ABRAMOVIC, B.: Application of Raymond Fisk Model in Research of Service Quality, *Communications - Scientific Letters of the University of Zilina*, No. 2, 2016, 11-14.
- [10] BUSHHELL, C.: *Jane's Urban Transport Systems 1993=94*, Jane's Information Group, Coulsdon: Surrey, 1994.
- [11] SIMPSON, B. J.: *Urban Public Transport Today*, E&FN Spon: London, 1994.

- [12] SIMS, L., BERRY, J.: *Various Ways of Recovering Increases in Land and Property Values - The Example of North America*, UITP seminar, Paris, October 1999.
- [13] KALASOVA, A., CERNICKY, L., KUBIKOVA, S.: Microscopic Simulation of Coordinated Route in the City of Zilina, *Communications - Scientific Letters of the University of Zilina*, No. 2, 2014, 46-50.
- [14] LIZBETIN, J., KAMPF, R., STOPKA, O., BARTUSKA, L., CEJKA, J.: The Current Status of Intermodal Transport Terminals in the Slovak Republic, *Horizonts of Railway Transport 2015: Anniversary*, vol. 1, 2015, 143-147, University of Zilina, ISBN 978-80-554-1097-5.
- [15] BLACK, A.: *Urban Mass Transportation Planning*. McGraw-Hill : New York, 1995.

Milos Poliak - Michaela Mrnikova - Marek Jaskiewicz - Rafal Jurecki - Barbora Kaciakova\*

## PUBLIC TRANSPORT INTEGRATION

*The importance of the issue of an effective mode of passenger transport is currently increasing. On the one hand there is an increasing economic demand for public passenger transport, on the other hand, there is a growing traffic share of individual automobile transport. The aim of this article is to define the importance of public passenger transport and to identify the problems of its operation. The integration of different modes of public passenger transport is proposed as a way to increase the competitiveness of public passenger transport. This paper analyses the individual elements of integration systems abroad and suggests the methodology of integration system applicable in regions where the share of public passenger transport is decreasing within the transport market.*

**Keywords:** *Integration, public transport, integration barriers, organisational integration, operational integration, physical (material) integration.*

### 1. Introduction

EU transport strategy prefers the transport of passengers by public passenger transport to the individual transport because the use of public passenger transport results in meeting all the goals of the EU strategy in the field of road safety. It relates mainly to the stabilization of the increased road transport claims on infrastructure whose expansion is problematic especially in built-up areas. Construction of a new expressway infrastructure caused by increasing transport operation is a long-standing problem due to the ageing of the population in the EU. The support of public passenger transport brings lower fuel consumption. This is the way how to attain another objective of the EU strategy in the field of transport that is the reduction of the EU's dependence on crude oil as a raw material that needs to be imported into the EU. Emission of air pollutants is another strategic goal that is fulfilled due to less diesel fuel consumption [1]. Based on the above considerations it has been concluded that the strategic objectives of the EU transport policy are achieved when population uses the public passenger transport. In this regard it has to be noted that it is necessary to support the public passenger transport and its competitiveness in relation to the individual automobile transport [2]. The aim of this paper is to identify the importance of public passenger transport and to define the effective method of creating the integrated transport systems.

### 2. The importance and problems of public transport

“Transportation is often referred to as the lifeblood of cities and regions because it provides the essential link of constantly moving population in this area, thereby helping to shape the region” [3]. To promote the sustainable and livable urban environments, private, public and non-motorised transport must functionally complement each other by forming balanced integrated systems.

However, in many cities today, transportation is characterised by the dominance of the cars, it means that there is a high auto-dependence in travel [4]. As long as there is sufficient infrastructure available (road and parking), the cars offer convenience of travel to travellers [5]. The increase of individual automobile transport in towns causes a decrease in travel speed, irregularity of public transport operation and it has also an impact on passengers in public transport. There is also congestion that prevents the accessibility to the destination points, especially those that are located in the city centre. The increase of individual automobile transport causes other problems such as decreasing road safety, increasing air pollution, traffic noise and global warming [6 - 7] While providers of public passenger transport operate only the key areas and places in certain territories, the car users benefit from a high quality of transportation in terms of availability and time. Car users usually do not consider the use of land and emission produced by road transport as a problem [8].

\* <sup>1</sup>Milos Poliak, <sup>1</sup>Michaela Mrnikova, <sup>2</sup>Marek Jaskiewicz, <sup>2</sup>Rafal Jurecki, <sup>3</sup>Barbora Kaciakova

<sup>1</sup>Faculty of Operation and Economics of Transport and Communications, University of Zilina, Slovakia

<sup>2</sup>Department of Automotive Vehicles and Transportation, Kielce University of Technology, Poland

<sup>3</sup>The Institute of Lifelong Learning, University of Zilina, Slovakia

E-mail: michaela.mrnikova@fpedas.uniza.sk

However, individual transport causes static problems, too. Parked vehicles are often obstacles for pedestrians, cyclists and the disabled [9]. Concerning these problems, the key issue is to cause a change in people's mobility behaviour towards lower car usage and to encourage them to travel using public means of transport, use more bikes and walk [10]. While operators serve key origins and destinations, it is too costly for them to provide direct service between all points and it is essential to coordinate different modes of transport in order to ensure smooth, convenient transport services involved in the transfer of passengers [11]. To minimise the public passenger transport time, which is greatly influenced by passenger transfer, the integration of public passenger transport aimed at coordinating and promoting the continuous passenger transportation and providing high quality services is required. Generally speaking, many definitions of public passenger transport integration can be found in literature, e.g. Hine [12], Ibrahim [13], Dydkowski [14], Hull [15], Preston [16], but the most popular are those formulated by Nosal and Solecka [17]:

- Integration is the organisational process, in which the elements of public transport system (network and infrastructure, fares and tickets, information and marketing, etc.) served by various operators, who use different modes of transport, interact more efficiently and closely. This results in general improvement in travel conditions and quality of service.
- Integration is the way in which the individual elements of public transport are embedded in the chain of movement.

Commonly, in the urban public transport services, the word 'integration' is used for solutions that guarantee a continuity of a "door to door" services [18]. Urban transport is to provide attractive chain of services in the relationship "door to door", making integration to be defined as the combination of [17]:

- different means of public transport,
- public and individual transport,
- transport policy with other policies concerning the spatial planning or investment in infrastructure.

Speaking of the public transport integration, we can take into consideration the Mohring effect that was defined in 1972: "If more passengers use public transport, the costs per passenger are lower. It means better transport services with shorter waiting time, denser network of routes and bus stops and shortening of walking time. Due to more passengers it is allowed to plan express links in order to reduce the distance travelled by a vehicle" [19]. At present the most significant factors in supporting the integration of public transport are road safety and the impact of transport on the environment. The integration of public transport is the latest trend in Western Europe that assumes the increase of attractiveness of public passenger transport [4] and the quality of public transport services. On the basis of public passenger transport integration, it is possible to develop a unified system that provides passengers with compatible timetables for different

modes of transport. The integration also plays an important role in social policy. According to Nielsen [20] the importance of transport integration creates an efficient transport system that leads to the reduction of traffic congestion and contributes to the protection of the environment. In practice, especially in Eastern Europe, it is often about the integration of fares, services and providing information [21]. According to Preston [16] this kind of integration represents only the first level of the following ones:

- integration of fares, services, terminals/bus stops and information on the public transport,
- provision of infrastructure integration, management, public and private transport pricing,
- integration of passenger and freight transport,
- integration with transport authorities,
- integration of transport measures with policy of land use planning,
- integration of general transport policy with transport education, health and social policy,
- integration of transport policy with other policies.

### 3. Integration levels of public passenger transport

According to Vuchic [3] the most important element of the increase in the number of passengers in public passenger transport is to increase the quality of service. It is required when multiple transfers and the coexistence of more than one operator lead to the necessity of coordination, cooperation and interaction among them to ensure the image of one unified system without confusing the potential users or allowing them to notice the interruption in the offered services. To define the integration of public transport it is necessary to divide it into three levels: organisational, operational and physical integration. [4].

#### 3.1 Organisational integration

One of the conditions necessary for the development of a well-integrated public transport system is that a responsible authority must be given the power to organise the integration of transport service standards [22]. The established authority is necessary due to the fact that there are several public authorities responsible for transport services in an operating area.

Urban transport serviceability is commonly provided by municipal authorities while regional transport serviceability is provided by regional authorities. For instance, in the Slovak Republic the regional bus transport is provided by the Office of self-government region – regional authority and regional rail transport is operated by the Central Government – Ministry

of Transport. The concept of transport serviceability was originated in Hamburg, Germany in 1960.

Originating in Hamburg, the concept of an integrated organisation was established as a reaction to the declining role of transport in the city's modal split. The concept of an integrated organisation still serves as a public authority that fully coordinates transport services in the region while preserving the individual entities of the component companies which are the ones actually responsible for supplying the services [23].

Unorganised transport serviceability can result in its significant reduction as shown by the cases from Great Britain [24]. Market liberalisation in the UK in the 1980s led to the fragmentation of public passenger transport [16] which caused the reduction of public transport serviceability. At present, there are two municipalities in the UK with population of more than 1,000 people that do not have daily regular transport services [25].

Moreover, organisational integration defines the contracts between the stakeholders ensuring their interest and commitment to the performance of public transport integration system. The established authority must take into account the expectations of public transport passengers; however, according to Rivasplata [11] the authority must also consider the commercial interests of the operators in order to identify the clear objectives of integration.

### 3.2 Operational integration

Operational integration refers to the coordination and planning of the transport system with minimum interruption in space and time in order to satisfy the passengers' expectations. It consists of an integrated network layout, synchronized schedules between different modes and routes of direct transport, integrated information about all services, common fares and convenient ticketing system [26]. Greiving and Wegener [27] also highlighted the importance of transport planning. Layout integration refers to the planning of the network without spatial discontinuities so that all routes, lines and modes are connected and coordinated in the most efficient way, allowing for convenient passengers' transfer. A clear hierarchy and structure of the system are required in combination with defined roles for each mode. Hierarchy promotes services that are easily remembered, uncomplicated, with direct routes when possible, and an efficient coverage of reliable travel routes [4]. Once the network has been harmonised, the optimisation of the system's operation requires the integration of schedules: the coordination and synchronization of arrival and departure times of the involved lines and modes. The aim is to reduce waiting, dwell-time, transfers and total travelling times. Within the operational

integration it is necessary to communicate with passengers [25].

The traditional view of transport integration is that travellers perceive transfers as negative experience due to the time, costs and uncertainty [28]. That is the reason why the integrated information system is needed. All necessary information about the entire transport system must be provided, regardless of the mode used and operator responsible for the service. The way in which the network is presented to the public can significantly affect the effectiveness of the public transport system [20]. Another key issue within the operational integration is convenient ticketing system. The integrated system can increase convenience by eliminating the need to purchase a ticket for each trip. Tickets and fares establish a common integration system for the involved operators and contribute to the improvement of transport convenience allowing passengers to travel between lines by purchasing a ticket for the entire service only once. Fares have an impact on both passengers and operators. By introducing a common fare system, competition between operators can be avoided and the collected revenue can be distributed according to the signed agreements.

Some authors, e.g. Wesolowski [29], Solecka [30] separate the infrastructure integration from the operational integration and consider it as an individual element of integration.

The infrastructure integration consists of an arranged combination of elements that make up the integrity of transport network. It relates to, first and foremost, all such elements as: location of bus stops, stations and interchange junctions for convenient changing of means of transport.

### 3.3 Physical integration

According to M. Miller [31] physical or infrastructure integration relates to physical changes such as integration of new routes and reorganisation of transfers points. It refers to the planning of bus stops, stations and transfer centres, their location and facilities, as well as their design. It also involves the coordination of vehicle movements for transfers to be safe, without any conflicts between pedestrians and moving vehicles. Physical integration aims at planning the system carefully through good station designs, convenient walking paths and station amenities in order to speed up and secure transfers, improve accessibility towards and inside the intermodal transport system for all traveller groups, facilitate the users' movement and minimise the discontinuities inside the system.

#### 4. Proposal of procedure for the integrated transport system implementation

In the first stage of the proposed procedure, it is important to focus on data collection in a specified area where the integrated transport system is to be implemented. Furthermore, it is necessary to identify the common transport systems in that area. The main objective of collecting data is to gather some knowledge about supply and demand in the area concerned [6], having regard to the identification of public transport fleet and its capacity, identification of line routes, number of passengers transferred and identification of transport and transfer services.

Another important aspect is to record operating speed of vehicles that relates to fuel consumption and emissions. These two aspects can be considered as the potential benefits of the proposed integrated transport systems, as opposed to the transport systems operating at present. After defining all parameters, it is necessary to create a data collection model used for the identification of the most important areas of public transport in the region and then it is required to include these areas into integration.

Data collection is done during morning and afternoon peak hours. However, data gathered during the off-peak period are also important because it helps to identify different conditions of public transport operation. Furthermore, it is necessary to admit that data acquired on Monday and Friday are modified because the flow of passengers is not regular in these days (e.g. commuting to other cities at the beginning and end of the week).

The second stage of procedure deals with the analysis of gathered data in order to emphasise the level of travel services for passengers using different travel routes. It is possible to speak of 'an extreme' (e.g. congestion) on travel routes and lines. Consequently, it is important to identify these extremes and suggest ways to avoid them. The outcome of second stage is to determine the total supply and demand for specific lines. To summarise the capacity of all vehicles within the transport system, it is possible to identify this capacity as a supply and the number of all travellers within the system as a demand. To confirm that, the traffic survey is needed.

Based on the current state of the system it is possible to propose various alternatives for implementing the integrated transport system in the third stage. According to Rodrigues a Santos [32] the alternatives are seen as hypothetical phases of a predetermined system which cannot be implemented at the same time. Alternatives are developed under the influence of certain variables that are characterised as the behaviour of all components. These alternatives should include the proposed travel routes, vehicles capacity, terminals and stops for passengers, the best combination between different modes

of transport or vehicles, from the passenger's point of view as well as the operator's view.

The fourth stage of the procedure deals with the analysis of serious alternative of integration with the suggested alternative of integration. This stage is the basis for calculating the benefits of integrated transport system, taking into account the already existing system. The system is considered to be effective if it meets all the requirements in terms of public transport users, i.e. passengers, as well as system operators and society as a whole.

The overall procedure should lead to the proposal of the observed aspects of different entities: users, operators, the public, assessment of waiting time, operating costs and pollution reduction [33].

#### 5. Barriers of integration

Speaking of the integration of public transport it is necessary to take into consideration some barriers. A barrier is an obstacle which prevents a given policy instrument from being implemented, or limits the way in which it can be implemented. In the extreme, such barriers may be overlooked and the resulting strategy may be much less effective. Barriers can be grouped into four main categories [34]:

- Legal and institutional barriers – these include lack of legal powers to implement a particular instrument,
- Financial barriers – these include budget restrictions limiting the overall expenditure on the strategy, financial restrictions on specific instruments, and limitations on the flexibility with which revenues can be used to finance the full range of instruments.
- Political and cultural barriers – these involve lack of political or public acceptance of an instrument, restrictions imposed by pressure groups which influence the effectiveness of instruments.
- Practical and technological barriers – while cities view legal, financial and political barriers as the most serious which they face in implementing land use and transport policy instruments, there may also be practical limitations. For expansion of public transport infrastructure, engineering designs may limit progress.

Integrated strategies are particularly effective in overcoming the second and third of these types of barrier and integration between authorities may help reduce institutional barriers as well. It is usually harder to overcome legal, institutional and technological barriers in the short term. It is often difficult to overcome a barrier without in so far reducing the performance of the overall strategy. The pursuit of synergy and the resolution of barriers are thus to some extent in conflict with the design of integrated strategies.

## 6. Conclusion

In modern cities, individual transport leads to serious problems related to: congestion on roads and environmental pollution. With increasing performances in road transport within the insufficient capacity of road network, the possibility of traffic accident is increasing and the road safety is decreasing. Therefore, it is extremely important to strive to change people's travel behaviour towards the use of more sustainable means of transport: public transport, bicycles, walks, car sharing and carpooling. It can be achieved by using the concept of the transport demand management. The aim is to support the city inhabitants to use public means of transport. The experience gained abroad show the importance of integrated transport. The liberalised operation of public

passenger transport in the UK led to the reduction of regional transport serviceability. Reduction of transport serviceability has caused the transfer of travellers to individual transport. The transport integration is not a simple process as indicated in this article. However, it is important to overcome the greatest barrier of integration - the lack of funds in public resources. The ways of obtaining financial resources is dealing Poliak et al [35].

## Acknowledgement

This work was supported by the Slovak Research and Development Agency under the contract No. SK-PL-2015-0019.

## References

- [1] KONECNY, V., GNAP J., SIMKOVA, I.: Impact of Fiscal Decentralization on Motor Vehicle Taxation in the Slovak Republic. *Transport and Telecommunication J.*, vol. 17, No. 1, 28-39, ISSN (Online) 1407-6179, DOI: <https://doi.org/10.1515/ttj-2016-0004>, February 2016.
- [2] POLIAK, M.: Relationship of Reasonable Profit and Risk in Public Passenger Transport in the Slovak Republic (in Slovak), *Ekonomicky casopis/J. of Economics*, vol. 61, No. 2, 2013, 206-220, published by Ekonomicky ustav SAV and Prognosticky ustav SAV : Bratislava, ISSN 0013-3035.
- [3] VUCHIC, V. R.: *Transportation for Livable Cities*, New Jersey : Rutgers, 1999.
- [4] KLOTILDI, S.: *Public Transport Integration: The Case Study of Thessaloniki*, *Transportation Research Procedia* 4, 2014, 535-552.
- [5] RIHA Z., TICHY, J.: *The Costs Calculation and Modelling in Transport*, *Transport Means* 2015, Kaunas : Kauno technologijos universitetas, 2015, 388-391, ISSN 1822-296X.
- [6] NEDELIAKOVA, E., SEKULOVA, J., NEDELIAK, I., ABRAMOVIC, B.: Application of Raymond Fisk model in Research of Service Quality, *Communications - Scientific Letters of the University of Zilina*, vol. 18, No. 2, 2016, 11-14, ISSN 1335-4205.
- [7] BANISTER, D.: *Unsustainable Transport. City Transport in the New Century*. London : Routledge, 2005.
- [8] KALASOVA, A., CERNICKY, L., KUBIKOVA, S.: Microscopic Simulation of Coordinated Route in the City of Zilina, *Communications - Scientific Letters of the University of Zilina*, No. 2, 2014, 46-50.
- [9] JELINEK, J.: Municipal Public Transport Line Modelling, *Communications - Scientific Letters of the University of Zilina*, No. 2, 2014, 4-8.
- [10] NOSAL, K., STAROWICZ, W.: Some Problems of Mobility Management (in Poland), *Transport Miejski i Regionalny*, 3, 2010.
- [11] RIVASPLATA, C.: *Three Perspectives on the Role of Competitive Tendering in the Integration of Public Transport*, 22<sup>nd</sup> Southern African Transport Conference (SATC), Pretoria, 2003.
- [12] HINE, J.: Integration Integration Integration ... Planning for Sustainable and Integrated Transport Systems in the New Millennium, Pergamon, *Transport Policy*, 7, 2000.
- [13] IBRAHIM, M. F.: Improvements and Integration of a Public Transport System: The Case of Signapore, *Cities*, vol. 20, No. 3, 2003, 205-216.
- [14] DYKOWSKI, G.: Integration of Local Collective Transport (in Poland), *Zeszyty Naukowe Politechniki Slaskiej, Transport*, 60, 2005.
- [15] HULL, A.: Integrated Transport Planning in the UK: From Concept to Reality, *J. of Transport Geography*, 13, 318-328, 2005.
- [16] PRESTON, J.: What's so Funny about Peace, Love and Transport Integration? *Research in Transportation Economics*, 29, 329- 338, 2010.

- [17] NOSAL, K., SOLECKA, K.: Application of AHP Method for Multi-Criteria Evaluation of Variants of the Integration of Urban Public Transport. *Transportation Research Procedia*, 3, 269-278, 2014.
- [18] JANIC, M., REGGIANI, A.: Integrated Transport Systems in European Union: An overview of Some Recent Developments. *Transport Reviews*, vol. 2, No. 4, 2001, 469-497.
- [19] MOHRING, H.: Optimisation and Scale Economies in Urban Bus Transportation, *American Economic Review*, 62, 591e604, 1972.
- [20] NIELSEN, G., et al.: *HiTrans Best Practise Guide 2: Public Transport-Planning the Networks*. HiTrans, 2005.
- [21] POLIAK, M., SEMANOVA, S., POLIAKOVA, A.: Risk Allocation in Transport Public Service Contracts (in Poland), *Ekonomski Pregled*, vol. 66, No. 4, 2015, 384-403, ISSN 0424-7558.
- [22] POLIAK, M., KRIZANOVA, A., SEMANOVA, S., GAJANOVA, L.: The Influence of Contract Form Choice of the Transport Services Ensuring on Performance Contracting Entity Requirement, *Transport Problems = Problemy Transportu: Intern. Scientific J.*, vol. 9, No. 4, 2014, 153-161, ISSN 1896-0596.
- [23] PUCHER, J., KURTH, S.: Verkehrsverbund: The Success of Regional Public Transport in Germany, Austria and Switzerland, (E. S. Ltd, Ed.), *Transport Policy*, 2, 279-291, 1996.
- [24] SCHOLLER-SCHWEDES, O.: The Failure of Integrated Transport Policy in Germany: A Historical Perspective, *J. of Transport Geography*, 18, 2010, 85-96, 2010.
- [25] POLIAK, M.: Marketing in Public Passenger Transport. *Perner's Contacts* [elektronik source], vol. 6, No. 4, 2011, 320-325, ISSN 1801-674X.
- [26] YIU KWOK KIN, A.: *An Integrated Public Transport System - A Case Study of Hong Kong*, University of Hong Kong, 2005.
- [27] GREIVINMG, S., WEGENER, M.: *Integration of Transport and Land Use Planning: State of the Art*. Proc. of the Ninth World Conference on Transport Research, Elsevier : Amsterdam, 2003.
- [28] KINGHAM, S., et al.: Travelling to Work: Will People Move out of their Cars. *Transport Policy*, 2001, 151-160.
- [29] WESOLOVSKI, J.: *A City in Motion. Best Practices in the Organisation of Urban Transport* (in Poland), Lodz : Instytut Spraw Obywatelskich, 2008.
- [30] SOLECKA, K.: *Multi-criteria Assessment of Possibilities for Integrated System of Urban Public Transport* (in Poland), doctoral thesis, Politechnika Krakowska, 2013.
- [31] MILLER, M. A.: *Assessment of Service Integration Practices for Public Transportation: Review of the Literature*, California Partners for Advanced Transit and Highways, 2004.
- [32] RODRIGUES, F. A. H., SANTOS, M. P. S.: *Generational Scenarios through Impact Analysis: Review of the Literature Applied to Evaluate Alternative Transport* (in Portugal), Anais do IX ANPET - Congresso de Pesquisa e Ensino em Transportes, vol. 2, 1995, 442-454, Sao Carlos.
- [33] VASCONCELLOS, S. C.: *Plan of Integration of Transport Systems in Rio de Janeiro* (in Portugal), Tese de M.Sc., PET/COPPE/UFRJ, Rio de Janeiro, 2002.
- [34] MAY, A. D., KARLSTORM, A., MARLER, N., MATTHEVS, B., MINKEN, H., MONZON, A., PAGE, M., PFAFFEBBICHLER, P., SHEPHERD, S.: *Developing Sustainable Urban Land Use and Transport Strategies. A Decision Makers' Guidebook*, 2<sup>nd</sup> ed., Institute for Transport Studies : Leeds, 2005.
- [35] POLIAK, M., SEMANOVA, S., VARJAN, P.: The Effectiveness of Supporting Public Passenger Transport from Public Funds. *Transport and Communications: Scientific J.*, No. 1, 2016, 10-16, ISSN 1339-5130.

Rudolf Kampf - Martina Hlatka - Gleb Savin\*

## PROPOSAL FOR OPTIMIZING SPECIFIC DISTRIBUTION ROUTES BY MEANS OF THE SPECIFIC METHOD OF OPERATIONAL ANALYSIS

*The paper focuses on the issue of optimizing material collection and distribution routes in the restrictive parameters. In the article, Clarke-Wright method was used, where the restricting parameters are vehicle capacity, vehicle speed and compliance with the social legislation related to the work of vehicle crew. The research aimed at the collection and distribution of steel components within a particular company. For the optimization, the data of weekly collection and distribution were used. By the Clarke-Wright method application, time savings of 40% of the vehicle use were achieved.*

**Keywords:** Clarke-Wright method, vehicle routing problem, route optimization

### 1. Introduction

Currently, when transportation is one of the most developing sectors of industry and emphasis is put on its requirements, both from the customer's and carrier's side [1 - 2]. Transport logistics employs a number of technical, technological, organizational and management methods in order to ensure the transfer of goods [3], so that the delivery of goods is timely, in the right place, of the required quality and with required documentation [4]. Its aim is to maximize the effectiveness [5] at all levels of the transport process. Therefore it is necessary to optimize the overall effect by the control system [6].

In transport operation, each transport enterprise strives for reasonable financial impact [7]. For that reason, it is convenient to optimize the distribution routes [8] at their beginning and when changing the distribution plan. To achieve this, several methods can be employed. For the research needs, the Clarke-Wright method was chosen.

### 2. Solving vehicle routing problems

Currently, the transport problems being solved most concern the issue of vehicle routing problem. The tasks of vehicle routing problems are defined in the transport network  $S = (V, H)$ , where  $V$  is a set of network nodes, while  $H$

designates the set of edges connecting the individual nodes of the network.  $V_0$  node is referred to as a centre point, whereas  $V_1, \dots, V_n$  nodes represent the locations with a service demand. The vehicle route always starts and finishes at  $V_0$  centre. The task being solved within the solution of the vehicle routing problem is to design vehicle routes so that the demand for location service is satisfied by one vehicle with minimal costs in terms of length and/ or time [9].

Two basic constraints for the admissibility of the solution result from the definition of the task [9 - 11]:

- 1) Each customer must be served just once within a route,
- 2) The capacity of the vehicles must not be exceeded.
  - In addition to the above mentioned preconditions, other conditions of the solution admissibility can be imposed on the set of vehicle routes being served, which modifies the original VRP, such as:
    - 1) general conditions:
      - The number of elements possible to be transported within one route,
      - Constraints of a maximum drive time possible, or the length of one route (vehicle staff working hours which cannot be exceeded, compulsory resting times, prohibition of drives on certain days etc.),
      - Constraints resulting from the maximum number of serviced locations within one route in terms of the demands and vehicle capacity,

\* <sup>1</sup>Rudolf Kampf, <sup>1</sup>Martina Hlatka, <sup>2</sup>Gleb Savin

<sup>1</sup>Department of Transport and Logistics, Faculty of Technology, Institute of Technology and Business in Ceske Budejovice, Czech Republic

<sup>2</sup>The Ural State University of Economics, Yekaterinburg, Russian Federation

E-mail: hlatka@mail.vstecb.cz

- Limited vehicle fleet; in the case of heterogeneous vehicle fleet, differences might be in technological capabilities and capacity of vehicles,
- 2) local conditions:
  - To respect time availability of the locations, i.e. to satisfy the demand of the location within a time window,
  - To respect technical availability of the locations, i.e. the customers demand for service by means of a vehicle of specific parameters,
  - Fuel consumption constraints; reasonable service costs etc. In the following part, the authors deal with the routing problem for the simple case, where a homogenous vehicle fleet is assumed, and where the vehicle route involves just one-circuit journey. If the drive time is limited, the route can consist of more circuit routes.

### 3. Methodology and method

For the research, Clark-Wright method was chosen, as it addresses the most typical multi-circuit routing problem with capacity constraints [9]. There is only one central point (a hub) from which the distribution and collection is carried out. From this point the distribution routes are conducted to other nodes. Each of the nodes has a different capacity. The total number of nodes must not exceed the vehicle capacity. There shall be a minimum total driving length.

This method is one of the older ones [12 - 13], with a focus on the solution of the vehicle routing problem. The method consists in choosing two routes (V0-Vi-V0) and (V0-Vj-V0). These routes are subsequently combined into one (V0-Vi-Vj-V0). Combining routes is possible provided that the vehicle capacity is not exceeded. The advantageousness or disadvantageousness of combining routes depends on the savings resulting from the combination. The savings are evaluated using  $z_{ij}$  coefficient of advantage, which is calculated as  $z_{ij} = (d_{0i} + d_{0j} - d_{ij})$ , where  $d_{0i}$ ,  $d_{0j}$ ,  $d_{ij}$  are distances assigned to edges (V0, Vi), (V0, Vj) and (Vi, Vj). The  $z_{ij}$  value is thus expressed as a difference between the sum of the route lengths (V0-Vi-V0) and (V0-Vj-V0) and the length of the combined route (V0-Vi-Vj-V0). The method combines the nodes with the higher  $z_{ij}$  coefficient of advantage in all iterations. The main advantage of this method is that the  $z_{ij}$  coefficient depends only on the distance between the nodes Vi, Vj and V0 and remains constant if these two nodes can be connected [13 - 14].

The above aforementioned method is employed in the following steps [9, 10 and 15]:

- 1) For the given transport network  $S = (V, H)$ , matrix of distance  $D = \{d(i, j)\}$  is created, where  $i, j = 0, 1, \dots, n; n = |V|$ . Usually, the S network does not have to be complete (i.e. in the graphical representation, it can be expressed by a graph

which is not a complete graph), which means that the entries of D matrix can express both the length of the sectors and the distances between the individual nodes. In addition the following values should be entered:

where:  $c$  is the average speed of the vehicle within the network;  $t$  is time necessary for unloading the unit quantity of the elements from the service vehicle;  $T$  is maximum time the vehicle is allowed to stay outside the starting V0 node;  $K$  is the vehicle capacity;  $q_i$  is quantity of elements being transported from V0 node to node Vi ( $i = 1, \dots, n$ )

- 2) It is necessary to set initial solution which represents a set of elementary (V0 - Vi - V0) for all network nodes  $i = 1, \dots, n$  with a given number of elements and transport times (it may be complemented also by the times necessary for unloading the elements from the vehicle)
- 3) From D matrix, we derive Z matrix of the coefficient of advantage  $Z = \{z_{ij}\}$ , where  $i, j = 1, \dots, n$  resulting from  $z_{ij} = d_{0i} + d_{0j} - d_{ij}$ , where  $z_{ij}$ , as established, expressed the difference between the sum of the route lengths (V0 - Vi - V0) a (V0 - Vj - V0) and the length of the combined route (V0 - Vi - Vj - V0).
- 4) In Z matrix, positive element with the highest value  $z_{ij}$  is identified and if possible, the routes (V0 - Vi - V0) and (V0 - Vj - V0) are combined into one combined route (V0 - Vi - Vj - V0). If there is no such element, it is the final step. The current set of circuit routes is the result of the algorithm. Otherwise, this step should be followed by step 5).
- 5) By combining (V0 - Vi - V0) and (V0 - Vj - V0) routes admissible route should arise. If the route is not admissible, then  $z_{ij}$  should be  $z_{ij} = 0$  and we should go back to step 4). Otherwise, this step should be followed by step 6).
- 6) V set of nodes is updated by excluding  $i$  and  $j$  nodes if they stopped being the outer nodes after combination of routes into one combined route. We establish  $z_{ij} = 0$ . The set of routes is updated by excluding combined routes and integrating a new route. At the same time, other monitored parameters (transport time, number of elements, route length etc.) is also updated. If step 4) and 5) is not possible, we must find the closest smaller or the same element and combine the routes.

The procedure is repeated until the Z matrix is exhausted or unless it is obvious that the vehicle capacity is exhausted and there is no point in looking for other solutions. The resulting solution is not always optimum, it is often just the suboptimal solution.

### 4. Determining the criteria for the application of clarke-wright method

In cooperation with a production company, for the application of Clarke-Wright method the route for distribution of steel components was chosen. The company has three

vehicles for the distribution of the goods to its customers and for collection of the prepared material and its transport back to the production point. For the needs of this research, a weekly collection was chosen handled by IVECO Stralis EEV 460. The roster of individual routes is seen in Table 1. The Table was compiled based on the records of the operation of the vehicles in the week of October 14, 2016 to October 18, 2016. As the company specializes in different business activities, it operates the transport services only for its own vehicles. The transport services are a part of service provided to the customers and does not optimize the distribution routes. Each vehicle serves 5 routes. For the service of the remaining routes the company hires contract freighters [16 - 17].

Existing routes Table 1

| Day | Route                       | Route length [km] | Mass [t] |
|-----|-----------------------------|-------------------|----------|
| Mo  | C. B. - Horazdovice - C. B. | 156               | 12       |
| Tue | C. B. - Vinor - C.B.        | 354               | 11       |
| Wed | C. B. - Kaplice - C.B.      | 64                | 9        |
| Thu | C. B. - Hustopece - C.B     | 485               | 24       |
| Fri | C. B. - Destna - C.B.       | 117               | 6        |
|     |                             | 1,176             | 62       |

Source: authors

Before the application of Clarke-Wright method, the route length is 1176 km and the mass of the transported material is 62t.

### 5. Forming of distance matrix and coefficient of advantage matrix

The basic step in the application of the aforementioned method is to form D (distance) matrix (see Table 2). The table was compiled according to Google maps.

Distance matrix

|          | steel/t- qi      |                  | 12t         | 11t   | 9t      | 24t       | 6t     |
|----------|------------------|------------------|-------------|-------|---------|-----------|--------|
| Matrix D |                  | 0                | 1           | 2     | 3       | 4         | 5      |
|          | <i>i/j</i>       | Ceske Budejovice | Horazdovice | Vinor | Kaplice | Hustopece | Destna |
| 0        | Ceske Budejovice | 0                | 75          | 161   | 31      | 238       | 55     |
| 1        | Horazdovice      |                  | 0           | 148   | 102     | 283       | 131    |
| 2        | Vinor            |                  |             | 0     | 190     | 245       | 138    |
| 3        | Kaplice          |                  |             |       | 0       | 267       | 85     |
| 4        | Hustopece        |                  |             |       |         | 0         | 183    |
| 5        | Destna           |                  |             |       |         |           | 0      |

Source: authors

Subsequently, from D matrix the matrix of coefficient of advantage will be derived (Z matrix). This matrix is formed based on the relation  $Z_{ij} = d_{0i} + d_{0j} - d_{ij}$ . The resulting Z matrix is seen in Table 3 [16 and 18].

Z matrix (coefficients of advantage matrix) Table 3

| <i>i/j</i> | 1 | 2  | 3 | 4   | 5   |
|------------|---|----|---|-----|-----|
| 1          | 0 | 88 | 4 | 30  | -1  |
| 2          |   | 0  | 2 | 154 | 78  |
| 3          |   |    | 0 | 2   | 1   |
| 4          |   |    |   | 0   | 110 |
| 5          |   |    |   |     | 0   |

Source: authors

### 6. Setting the initial elementary solution

Based on D (distance) matrix, initial solutions are set with regard to restricting. The time fixed for loading and unloading is 30 min. The determined average speed is 70 km/hour and the maximum vehicle load is 24t. Drivers' working hours are set in accordance with the Labor Code in force [16, 18 and 19] - Table 4.

### 7. Discussion and resolutions

At this moment, the individual iterations according to the procedure step will be carried out [16, 17, 20 - 22].

- Iteration 1 with max.  $z_{ij}$ . In Z matrix, positive element with the highest value ( $z_{ij}$ ) will be found and the individual routes will be combined into one. In this case, it is number 154 which serves vertices V2 and V4. Based on this relation, route V0-V2-V4-V0 arises, with a total length of 832 km. By carrying out this iteration, the vehicle capacity would be exceeded. Therefore another more suitable combination will be sought.

Table 2

Initial elementary solution

Table 4

| Elementary routes | mass [t] | Route length [km] | Drive time [hours] | Rest periods [hours] | Loading and unloading[hours] | Total time [hours] |
|-------------------|----------|-------------------|--------------------|----------------------|------------------------------|--------------------|
| V0-V1-V0          | 12       | 150               | 2.14               | 0                    | 0.5                          | 2.64               |
| V0-V2-V0          | 11       | 322               | 4.6                | 0.75                 | 0.5                          | 5.85               |
| V0-V3-V0          | 9        | 62                | 0.85               | 0                    | 0.5                          | 1.35               |
| V0-V4-V0          | 24       | 480               | 6.85               | 0.75                 | 0.5                          | 8.1                |
| V0-V5-V0          | 6        | 116               | 1.65               | 0                    | 0.5                          | 2.15               |

Source: authors

2. Iteration 2. We go on searching for a suitable solution with max  $z_{ij} = 110$ . The resulting route of this iteration is V0-V4-V5-V0. By carrying out this iteration, a route with exceeded vehicle capacity arises again, therefore will continue with iteration 3.
3. Iteration 3 with max.  $z_{ij} = 88$ . The combined route is accessible, as seen in Table 5, from which V0-V1-V2-V0 route arises. The length of the route is 472 km, the total time is 8.49 hours.
4. Iteration 4 with max.  $z_{ij} = 78$ . This iteration combines V0-V1-V2-V0 route, with V5 vertex. The vehicle capacity would thus be exceeded, since the driver's working hours would be exceeded.
5. Iteration 5 with max.  $z_{ij} = 30$ , concerning V4 vertex. Independent V0-V4-V0 route arises, as seen in Table 6.
6. Iteration 6 with max.  $z_{ij} = 4$ . This iteration would combine V0-V1-V2-V0 with V3 vertex. This is not admissible in terms of the driver's working hours.

Iteration 3

Table 5

| Route       | q1+q2 | Route length | Drive time | Loading + unloading | Rest period | Total time |
|-------------|-------|--------------|------------|---------------------|-------------|------------|
| V0-V1-V2-V0 | 23    | 472          | 6.74       | 1                   | 0.75        | 8.49       |

Source: authors

Iteration 5

Table 6

| Route    | Q4 | Route length | Drive time | Loading + unloading | Rest period | Total time |
|----------|----|--------------|------------|---------------------|-------------|------------|
| V0-V4-V0 | 24 | 480          | 6.85       | 0.5                 | 0.75        | 8.1        |

Source: authors

Iteration 7

Table 7

| Route    | Q3 | Route length | Drive time | Loading + unloading | Rest period | Total time |
|----------|----|--------------|------------|---------------------|-------------|------------|
| V0-V3-V0 | 9  | 62           | 0.88       | 0.5                 | 0           | 1.38       |

Source: authors

Iteration 8

Table 8

| Route       | Q3 | Route length | Drive time | Loading + unloading | Rest period | Total time |
|-------------|----|--------------|------------|---------------------|-------------|------------|
| V0-V3-V5-V0 | 15 | 178          | 2.54       | 1                   | 0           | 3.54       |

Source: authors

Resulting routes

Table 9

| Route       | Q  | Route length | Drive time | Loading + unloading time | Rest period | Total time |
|-------------|----|--------------|------------|--------------------------|-------------|------------|
| V0-V1-V2-V0 | 23 | 472          | 6.74       | 1                        | 0.75        | 8.49       |
| V0-V3-V5-V0 | 15 | 178          | 2.54       | 1                        | 0           | 3.54       |
| V0-V4-V0    | 24 | 480          | 6.85       | 0.5                      | 0.75        | 8.1        |
| In total    |    | 1,130        |            |                          |             | 20.13      |

Source: authors

7. Iteration 7 with max.  $z_{ij} = 2$ . The resulting route is V0-V3-V0, with a total length of 62 km (see Table 7).
8. Iteration 8 with max.  $z_{ij} = 1$ . V0-V3-V0 route is combined with V5 vertex. The resulting route is V0-V3-V5-V0 - Table 8.
9. The outcomes of the individual steps are summarized in Table 9

By applying the Clarke-Wright method it was found out that a substantial reduction in mileage is possible. Initially, there were 5 routes with the total length of 1,172 km. The company vehicles served the customers Monday to Friday, every day in a week. The customers who are not served by the company vehicles are served by means of the contract freighter hired by the company. By applying the Clarke-Wright method the number of routes was reduced. There was a decrease in mileage which will be reflected in the overall costs of the production company. The total length of the routes was reduced by 42 km in the whole week [22 - 24].

## 8. Conclusion

Nowadays, every company strives for reducing costs at all levels [21]. Each company focuses on its main business activities. Its weaknesses are in the areas they do not give 100% attention [25]. As regards the company mentioned in the study, the greatest attention is paid to production related activities. The transport services are provided only to its customers. In this area, the costs are not too high; therefore the company has not dealt with the issue yet. In the agreement with the company, the Clarke-Wright method was applied on one distribution [16 and 25].

Resulting from the application of the method, it was found out that cost savings would be possible in terms of reducing the number of routes and decrease in mileage within the routes. Based on the results of this research, the analyzed company could use the free days for serving other customers [19 and 24].

## References

- [1] KAMPF, R., LIZBETIN, J., LIZBETINOVA, L.: Requirements of a Transport System User, *Communications - Scientific Letters of the University of Zilina*, vol. 14, No. 4, 2012, 106-108, ISSN 1335-4205.
- [2] NEMEC, F., LORINCOVA, S., HITKA, M., TURINSKA, L.: The Storage Area Market in the Particular Territory, *Nase More*, vol. 62, Special Issue, 2015, 131-138, doi 10.17818/NM/2015/SI8.
- [3] BARTUSKA, L., CEJKA, J., CAHA, Z.: The Application of Mathematical Methods to the Determination of Transport Flows, *Nase More*, vol. 62, No. 3, 2015, 91-96, ISSN 0469-6255, doi:10.17818/NM/2015/SI1.
- [4] REZNICEK, B.: *Logistics Circulation Processes*, Pardubice: University of Pardubice, 2002, ISBN 80-7194-506-4.
- [5] SVOBODA, V.: *Transport Logistik*, Praha: Czech Technical Institute in Prague, 2004, ISBN 80-01-02914-X.
- [6] KUMAR, S. A.: *Production and Operations Management*, New Age International, 2006.
- [7] HITKA, M., LIZBETINOVA, L., CAHA, Z., XU, Y.: Facility Management – Instrument for the Management of Support Processes for HRM Outsourcing, *Communications - Scientific Letters of the University of Zilina*, 2016, vol. 18, No. 2, 113-117, ISSN 1335-4205.
- [8] STOPKA, O., KAMPF, R., KOLAR, J., KUBASAKOVA, I.: Identification of Appropriate Methods for Allocation Tasks of Logistics Objects in a Certain Area, *Nase More*, 2014, vol. 61, No. 1-2, 1-6, ISSN 0469-6255.
- [9] CLARK, G., WRIGHT J.: *Operations Research*, Baltimore: Operations Research Society of America, 1964, ISSN 0030-364X.
- [10] SRINIVASAN, G.: *Operations Research: Principles and Applications*, PHI Learning Pvt. Ltd., 2010.
- [11] SULGAN, M., SOSEDOVA, J.: Rationalization of Internal Transport Operation in The Intermodal Transport Terminal, *Communications - Scientific Letters of the University of Zilina*, vol. 18, No. 2, 2016, 5-10, ISSN 1335-4205.
- [12] BRAIL, R. K., KLOSTERMAN, R. E.: *Planning Support Systems: Integrating Geographic Information Systems, Models and Visualization Tools*, ESRI, Inc., 2001.
- [13] BEKTAS, T.: The Multiple Traveling Salesman Problem: An Overview of Formulations and Solution Procedures, *Omega*, vol. 34, No. 3, 2006, 209-219.
- [14] STOPKA, O., KAMPF, R.: Determining the Most Suitable Layout of place for the Loading Units' Handling in the Maritime Port, *Transport*, 12 April 2016, 1-11, ISSN 1648-4142, doi: 10.3846/16484142.2016.1174882.
- [15] SULGAN, M.: *Trip Generation and Attraction in the Transport Planning Process*, Studies of Faculty of Operation and Economics of Transport and Communications : University in Zilina, 2003, No. 19, pp. 173-176.
- [16] DEIF, I., BODIN, L.: *Extension of the Clarke and Wright Algorithm for Solving the Vehicle Routing Problem with Backhauling*. Proc. of the Babson conference on software uses in transportation and logistics management, 1984, Babson Park, MA. pp. 75-96.

- [17] TANG, L., LIU, J., RONG, A., YANG, Z.: A Multiple Traveling Salesman Problem Model for Hot Rolling Scheduling in Shanghai Baoshan Iron & Steel Complex, *European J. of Operational Research*, vol. 124, No. 2, 2000, 267-282.
- [18] LIZBETIN, J., CERNA, L., LOCH, M.: Model Evaluation of Suppliers in Terms of Real Company for Selected Criteria, *Nase More*, vol. 62, No. 3, 2015, 147-152, ISSN 0469-6255, doi:10.17818/NM/2015/SI11.
- [19] SIROKY, J., SLIVONE, M., CEMPIREK, V.: Single and Multiple Allocation in Hub-And-Spoke Networks and the Transportation Cost Comparison, *Logi - Scientific J. on Transport and Logistics*, vol. 1, No. 2, 2010, 52-62, ISSN 1804-3216.
- [20] PESKO, S., MAJER, T.: Robust p-median Problem in Changing Networks, *Transport Problems*, vol. 10, No. 1, 2015, 125-130, ISSN 1896-0596.
- [21] KAMPF, R., HITKA, M., POTKANY, M.: Inter-Annual Differences in Employee Motivation in Manufacturing Enterprises in Slovakia, *Communications - Scientific Letters of the University of Zilina*, vol. 4, 2014, University of Zilina, 98-102, ISSN 1335-4205.
- [22] KLIESTIK, T.: Quantification Effectiveness Activities Traffic Company by the Rules of Data Envelopment Analysis, *E & M Ekonomie a Management*, vol. 12, 2009, 133-145, Liberec, ISSN 1212-3609.
- [23] STOPKA, O., KAMPF, R., KOLAR, J., KUBASAKOVA, I., SAVAGE, CH.: Draft Guidelines for the Allocation of Public Logistics Centres of Intern. Importance, *Communications - Scientific Letters of the University of Zilina*, vol. 16, No. 2, 2014, 14-19, ISSN 1335-4205.
- [24] KRILE, S., PERAKOVIC, D., REMENAR, V.: Possible Collision Avoidance with Off-Line Route Selection, *Promet & Transportation*, vol. 21, No. 6, 2009, 415-423, ISSN 0353-5320.
- [25] MAJERCAKOVA, E., MAJERCAK, P.: Application of Clarke-Wright Method for Solving Routing Problem in Distribution Logistics, *Logi - Scientific J. on Transport and Logistics*, vol. 6, No. 1, 2015, 90-99, ISSN 1804-3216.

Jana Stofkova - Katarina Gasova\*

## FORMS OF CITIZENS' COMMUNICATION WITH THE PUBLIC ADMINISTRATION INSTITUTIONS

*Globalisation and technological development have caused many changes that force both businesses and governments to react. The development of information and communication technologies has changed the way how people obtain information, communicate, work, buy goods and affect their everyday lives. The revolution of the Internet has opened new opportunities for all economic operators. This process can not be stopped. The government which wants to meet the citizens' changing demands and needs has to be flexible and adapt to this progress, which results in e-Government. The contribution focuses on the ways of communication between citizens and institutions of public administration and evaluates their satisfaction with provided e-Government services.*

**Keywords:** E-Government services, public administration, communication, citizens, satisfaction index.

**JEL Classification:** H11, M00, F60

### 1. Introduction

The growing importance of information-communication technologies (ICT) in everyday life is a key component of the knowledge society development. The daily use of ICT is not an essential part only for businesses, but also for citizens and governments. The government considers education, science, research and innovation, informatisation and digitalisation as the essential pillars of the knowledge-based society and economy. The reduction of disparities among the citizens as well as of the digital divide is one of the main government responsibilities. To reduce the digital divide means that knowledge becomes ubiquitous and available to everybody without restriction, which affects all sectors of the society. The building of a solid ICT infrastructure should be a part of the government national strategy. Governments should lead by example in the digitisation of the internal and external work as a part of the e-Government strategy. It results in the building and implementation of e-Government, e-services for citizens and e-Governance and becomes an important part of the knowledge society.

### 2. Public administration electronisation

E-Government is an electronic form of public administration in the application of information and communication

technologies in public administration processes [1]. The aim of e-Government is to reduce unproductive time spent by dealing with official matters, to minimise error rates and eliminate duplication of the same acts. In the future citizens and businesses will be allowed to arrange official matters in one place or directly from home or office via a computer [2 and 3].

#### 2.1 The effective, reliable and open public administration

It has been the largest reform of the state administration since 1989. The aim of the reform is to streamline the functioning, ensure the quality, accessibility and transparency of public administration for citizens [4 and 5]. The implementation of the effective, reliable and open public administration (ESO) will help to reduce costs and optimise the functioning of public administration, simplifying the processing of the official matters for citizens and businesses at the institutions of public administration. Citizen uses the government services at one office which is located near the place of residence. The ESO is a comprehensive reform which was divided into several stages because of its complexity. The aim of the first stage was an integration of the specialised local state administration. The specialised local state administrations were cancelled on January 1<sup>st</sup>,

\* Jana Stofkova, Katarina Gasova

Faculty of Operation and Economics of Transport and Communications, University of Zilina, Slovakia

E-mail: jana.stofkova@fpedas.uniza.sk

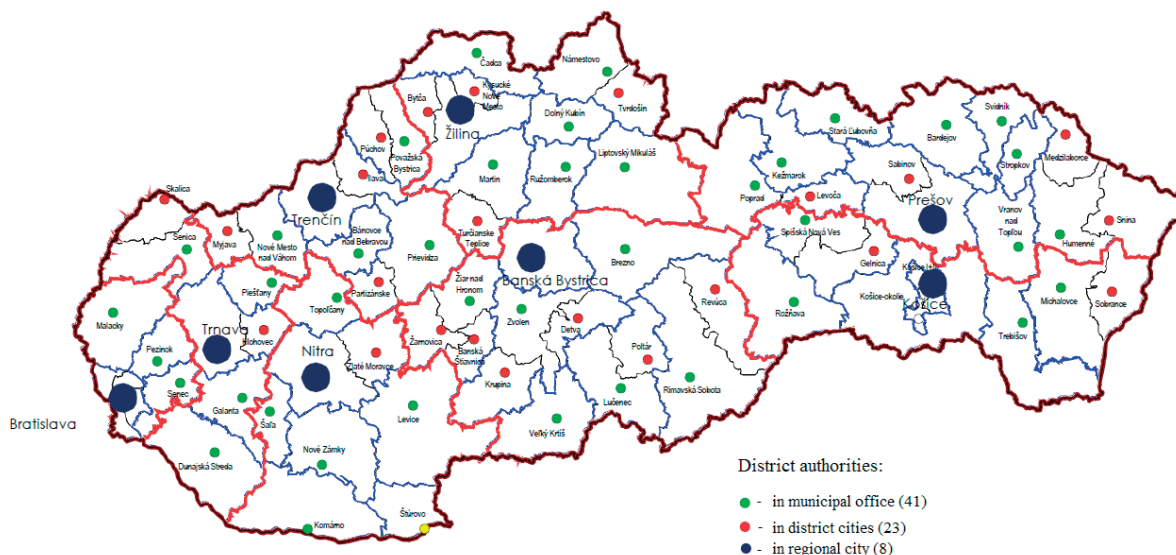

Fig. 1 District authorities created during the ESO reform (Source: [8])

2013 at the regional level. The creation of a uniform and clear structure of the local governments on October 1<sup>st</sup>, 2013 was the essence of the second integration stage. The activities of selected offices of the specialised state administration were concentrated in a government office at the local level. 72 district authorities were established in the Slovak Republic as shown in the following Fig. 1 [6 and 7].

The agenda of district authorities consists of the agenda of original district authorities (local government, business, birth record, misdemeanours, citizenship, etc.) and the agenda of the integrated specialised state administration authorities. 248 district authorities were cancelled: environment, road traffic and roads, forest and cadastral. 49 from original 50 became district authorities. 23 new district authorities were created for an integrated agenda of government and as a base (back-office) for more accessible services to citizens, which will be provided by the Client centre (front-office). The ESO reform is gradually implemented as follows:

- the integration of the specialised local state administration - by mid 2014,
- client services centres for citizens - 2014/2015, and
- the state administration optimisation, optimisation of processes and structures of the central public administration authorities and the optimisation of processes and the government performance - from 2014 to 2020 [8 and 9].

## 2.2 The Effective public administration 2014-2020

The managing authority of the Operational programme the Effective public administration is the Ministry of Interior of the Slovak Republic. The working team of the Ministry of

Interior received a financial support from the European Social Fund for the programming period 2014 - 2020 amounting to more than 335 million euros. An ambition of the Operational programme is to provide citizens with necessary public services at every stage of their life or business in financial and time saving manner. The programme aims to provide public services quickly and efficiently in order to promote a sustainable growth, job creation and social inclusion defined in the Europe 2020 strategy. The programme strategy reflects to requirements of the European Union legislation in relevant areas. The implementation of the Operational programme will contribute to meeting the national strategic goal of a modern, professional, efficient, reliable, non-corrupt and transparent public administration in the Slovak Republic in 2020 [9 and 10].

The Operational programme supports two basic aims according to building a customer-oriented, professional and transparent public administration. The first ambition is to support systems and processes of the public administration including institutional capacity strengthening and transparent procurement rules. The second priority is a major reform of the judiciary, streamlining the judicial system and increase law enforcement. The Operational programme covers the whole territory of the Slovak Republic and the main target groups are state authorities, local governments, social partners, civil society organisations, non-governmental organisations, other stakeholders and partners. The government of the Slovak Republic approved the Operational programme Effective public administration by resolution No. 228 on May 14<sup>th</sup>, 2014 [10 and 11].

### 3. Key access components

The public is able to communicate with the public administration authorities through various communication channels, e.g.: the Internet, telephone and personal contact. The central access components were built for various communication channels: the central public administration portal, specialised portals, client centres, contact centre and Integrated Citizen Service Points [12].

*Central contact centre* (call centre) is used to provide telephone information about services and activities of the public authorities. The centre is established and operated by the Government Office of the Slovak Republic. Citizens can obtain information on agendas provided by the district authorities, the addresses and office hours of the integrated public administration authorities and client centres on free phone number 0800 222 222. The domicile of the call centre is the Ministry of Interior department in Banska Bystrica. The call center was set up on the internal personnel and technical resources from the Ministry of Interior with zero external costs [12].

*The specialised portal* is an information system of the public administration which provides electronic official communication with one or more public authorities via the Internet [12].

Citizens and businesses who prefer personal contact can visit *Client centres* [12].

*The central public administration portal* is a public administration information system of the Slovak Republic available through: [www.slovensko.sk](http://www.slovensko.sk). The portal enables citizens to communicate electronically with all public authorities and to access the common modules via the Internet. The Government Office of the Slovak Republic is the administrator of the central portal and is operated by the National agency for network and electronic services (NASSES). The portal is divided into the following sections: citizen, business and public administration. [12].

The Slovak post, Inc. is one of the main providers of e-Government services. Services are provided in more than 100 cities in 602 workplaces evenly distributed across the Slovak Republic. Visitors can use a payment system called e-Kolok and public services through Integrated Citizen Service Points [12].

#### 3.1 The Internet as a suitable communication medium

The Internet is a global communication network that allows computers worldwide to connect and exchange information. The beginning of its creation is connected to the initiation computer networks projects in 1957. Until today the

development of the Internet and information-communication technologies has caused various changes [13].

The Internet brings many advantages e.g. rapid exchange of information, sharing of data services such as Internet banking, e-business, new jobs opportunities and education. We can conclude that the Internet is a suitable communication tool for e-Government services according to its benefits and availability 24/7. However it is necessary to ensure safe and quality e-Government services through the secure broadband connection [14].

Trend in the number of Internet users in the Slovak Republic is increasing every year approximately by 5%. As expressed by the following figure the Internet is currently used by 4 477 641 Slovak citizens (Fig. 2) [14].

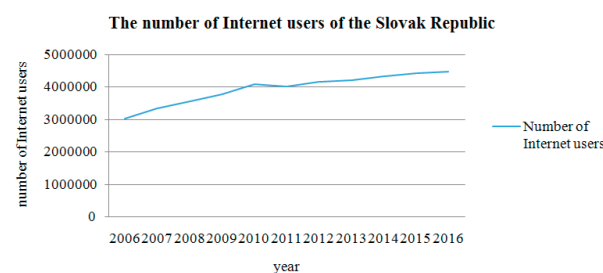

Fig. 2 The number of Internet users of the Slovak Republic  
(Source: [14])

Currently there are 1 273 812 fixed and 3 685 683 mobile broadband connections to the Internet in the Slovak Republic. Steadily increasing number of regular Internet users is undeniable proof that the Internet is a very suitable tool for communication with the public administration [14].

### 4. Aim of contribution, material and methods

Authors aim to introduce e-Government in the Slovak republic and to evaluate citizens' satisfaction with provided e-Government services. Theoretical basis gives a description of public administration electronisation. The current state analysis describes the ESO reform of public administration in the Slovak republic, the key access components and the impact of the Internet. The contribution presents the most used ways of citizens' communication with public administration and the loyalty index, based on results of the current state analysis and citizens' satisfaction survey.

Relevant information sources, necessary for the fulfilment of the aim were used:

- domestic and foreign book literature,
- scientific contributions and publications,
- European Commission report on e-Government, and

- results of citizens' satisfaction survey carried out by TNS Slovakia.

During the research authors used following methods:

- method of data collection for the theoretical basis creation,
- method of analysis during the description of current state in the Slovak republic and evaluation of citizens' satisfaction with provided e-Government services,
- indexes method for the loyalty index calculation and presentation of its evolution over time, and
- method of synthesis used for conclusions creation.

Authors used the Excel program for the indexes calculation.

### 5. Citizens' satisfaction analysis with the e-Government services

In December 2014, TNS Slovakia carried out a survey based on the instructions of the Ministry of Finance of the Slovak Republic. 1012 citizens aged from 18 to 65 participated in the satisfaction survey. The survey was designed to provide relevant information about customer satisfaction with e-Government services. The following figure displays the preferred ways of citizens' communication with the public administration institutions (Fig. 3) [15].

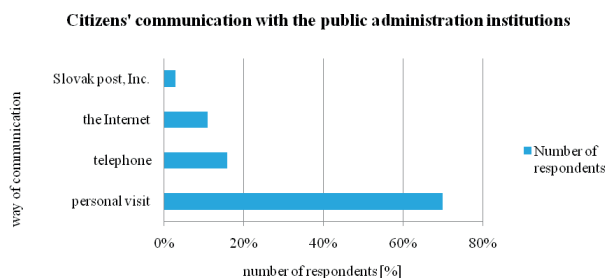

Fig. 3 Citizens' communication with the public administration institutions (Source: [15])

Most of the citizens prefer personal communication with the public administration institutions. This may be caused by the current complexity of the Central portal and imperfections of provided services which require personal retrofit. 16% of respondents prefer telephone contact and 11% of respondents prefer electronic form of communication with the public administration. The least used form of communication is through the Integrated Citizen Service Points.

The survey results show that the preferred source of e-Government services information is the Internet search engine and traditional media such as a television and print media. As expressed by the following figure, respondents, who regularly use the Internet, search the most information about the official matters and download sheets and forms from websites of the public administration institutions (Fig. 4) [15].

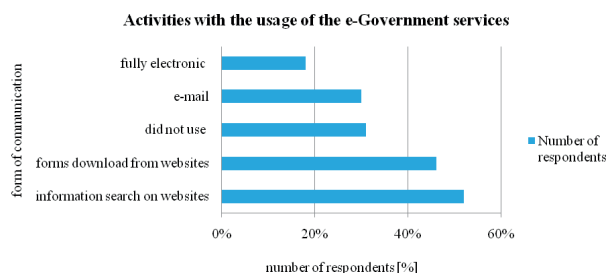

Fig. 4 Activities with the usage of the e-Government services (Source: [15])

18% of respondents communicate with their municipality or city with applications and 40% of respondents prefer applications which are accessible via smart phone or tablet in communication with the public administration. 76% of 1 012 respondents are regular Internet users who usually use a computer or laptop to connect to the Internet. The Internet is most frequently used to find necessary information for everyday life (83%) and to find information about goods and services (73%). Compared to previous years citizens prefer more to communicate through social networks, social media, instant messaging and online shopping as well as internet banking. On the contrary, the number of citizens communicating via e-mail has decreased. 40% of respondents have never heard about e-Government services and the most common form of communication with the public administration authorities remains a personal visit. Citizens use the Internet for the creation of applications for universities, job search and obtain information from the Land Register e. g. abstract of the Title deed. The Internet is least used in the field of property taxes, the change of residence notifications, with personal documents and vehicle registration. The usage of the e-Government services dropped to 38% in 2014, compared to 2013 it is a decrease of 8% [15 and 16].

### 6. The e-Government services satisfaction index

A variety of methods are used for the evaluation of satisfaction with provided e-Government services. Authors used one of the most common method - indexes. The calculation was focused on the calculation of the loyalty index and its evolution over time. *The loyalty index* reveals through the single summary number the general attitude of e-Government services users. The loyalty index includes: the satisfaction index, the recommendation index and the reuse index of the e-Government services in future. Data obtained from a survey carried out in December 2014 by TNS Slovakia on a sample of 1 012 citizens were a resource for the calculations [17].

*The satisfaction index* reflects the subjective feeling of citizens' satisfaction with the provision of the public services

or official matters online. Stated scales were allocated to answers; the response “certainly satisfied” gained 100 points, “more satisfied” 66 points, “rather dissatisfied” 33 points and “certainly dissatisfied” 0 points.

*The recommendation index* is an indicator of the experience which respondents gained during the use of the e-Government services and the resulting attitude that either leads to the recommendation to friends to use the e-Government services or not. 100 point scale was again used for the calculation, where 100 is a positive experience and respondent recommends to friends to use the e-Government services and, contrariwise, 0 represents a negative experience and unambiguous non-recommendation of services to friends.

*The reuse index* of the e-Government services in the future is to build on the experience of the citizens which they have gained during the use of e-Government services and assess whether the electronic form of official matters led effectively to achieving the target. For the calculation a 100 point scale was used. 100 points reflect the maximum satisfaction and unambiguous decision to use the e-Government services again and 0 points indicates unambiguous rejection of the e-Government services in the future.

The loyalty index

Table 1

| Year | Index        |              |                |              |
|------|--------------|--------------|----------------|--------------|
|      | Satisfaction | Future usage | Recommendation | Loyalty      |
| 2014 | 72.31        | 83.38        | 79.44          | <b>78.38</b> |
| 2013 | 65.88        | 81.8         | 75.49          | <b>74.39</b> |
| 2012 | 68.18        | 79.1         | 77.33          | <b>74.87</b> |
| 2011 | 63.96        | 68.8         | 70.34          | <b>67.7</b>  |
| 2010 | 67.07        | 73.86        | 77.77          | <b>72.9</b>  |

Source: Authors

Based on the previous findings we can conclude that respondents have rather positive attitude to the e-Government services as shown in Table 1. The loyalty index in 2014 reached 78.38 points out of 100 and compared to 2013 increased by 3.99 points. The loyalty index has currently a growing trend.

## 7. Conclusions

E-Government leads to more effective, citizen oriented public administration and brings time and financial savings for all involved stakeholders. The building and implementation of e-Government in the Slovak Republic face different problems. It is difficult for citizen to understand where to click or what service to search for on the Central portal [www.slovensko.sk](http://www.slovensko.sk). Services are hidden under complicated names which are often understandable only to an officer or a programmer. Many e-Government services which are available electronically also require a personal visit to the public administration authority. The development of e-Government should be focused on the modern technologies such as identification through smart phone. The elimination of these and other problems are the responsibility of the newly established Office of the Deputy Prime Minister for investment and informatisation. The Government of the Slovak Republic plans to cooperate with the professional community, enhance communication with non-profit sector and various initiatives which have evaluated the current development rather critically.

## Acknowledgement

This contribution was undertaken as parts of the research projects VEGA 1/0733/15 and VEGA 1/0693/16.

## References

- [1] COREJOVA, T. et al.: Regional Dimensions of Knowledge Processes in the Sector of Transport and Logistics and ICT in the Zilina Region. *Communications - Scientific Letters of the University of Zilina*, vol. 15, No. 2, 2013, 25-33, ISSN 1335-4205.
- [2] OECD (2003) *The e-Government imperative*. Paris, France. pp. 23-25. [Online]. Available: [http://www.keepeek.com/Digital-Asset-Management/oecd/governance/the-e-government-imperative\\_9789264101197-en#\\_V965S\\_mLTIU#page23](http://www.keepeek.com/Digital-Asset-Management/oecd/governance/the-e-government-imperative_9789264101197-en#_V965S_mLTIU#page23)
- [3] HEEKS, R.: *Implementing and Managing eGovernment: An International Text*. 1<sup>st</sup> ed. London: Sage, 2006. ISBN 0761967923.
- [4] KEIL, R. et al.: Communication Networks as Base for Mobility - trend Development of Network Architectures. *Communications - Scientific Letters of the University of Zilina*, vol. 17, No. 2, 2015, 80-85, ISSN 1335-4205.
- [5] KLOBUCNIK, M., BACIK, V.: Local Self-Government Structure in the EU Member States in 2011. *J. of Maps*, vol. 12, No. 4, 2016, 671-675.
- [6] KRIZANOVA, A., MASAROVA, G., KOLENCIK, J.: The Customer Contentment with Products and Services in Telecommunications Sector in the Slovak Republic. *Communications - Scientific Letters of the University of Zilina*, vol. 16, No. 2, 51-57, 2014.
- [7] MAJERNIK, M., DANESHJO, N., REPKOVA STOFKOVA, K.: Modeling the Process of Business Management Systems Control. *Communications - Scientific Letters of the University of Zilina*, vol. 18, No. 2, 2016, 93-98, 2016.

- [8] Ministerstvo vnútra SR. *ESO - Efektívna, Spolahlivá a Otvorená verejná správa*. [Online]. Available: <<http://www.minv.sk/?eso-efektivna-spolahliva-otvorena-verejna-sprava>>
- [9] SAGAT, V., NEMEC, J., KLIMOVSKY, D.: *What Kind of Control is Delivered by Regional Self Government in Slovakia*. Current Trends in Public Sector Research 2015: Intern. Conference [19<sup>th</sup>]. Slapanice, 78-83, 2015.
- [10] SILCOCK, R.: What is E-government. *Parliamentary Affairs*, vol. 54, No. 1, 88-101, 2001.
- [11] STOFKOVA, K., STOFKOVA, J.: *Implementation of the Knowledge Management as a Competitive Advantage*. 2<sup>nd</sup> Intern. conference on education and new learning technologies. Barcelona, 2010, 1323-1328.
- [12] European Commission. *eGovernment in Slovakia*. [Online], pp. 5, 2016. Available: [https://joinup.ec.europa.eu/sites/default/files/ckeditor\\_files/files/eGovernment%20in%20Slovakia%20-%20February2016\\_v1\\_00.pdf](https://joinup.ec.europa.eu/sites/default/files/ckeditor_files/files/eGovernment%20in%20Slovakia%20-%20February2016_v1_00.pdf)
- [13] SPIRAKIS, G., SPIRAKI CH., NIKOLOPOULOS K.: The Impact of Electronic Government on Democracy: e-democracy through e-participation. *Electronic Government, an Intern. J.*, vol. 7, No. 1, 75-88, 2010.
- [14] Internet Live Stats (2016) *Slovakia internet users*. [Online]. Available: <http://www.internetlivestats.com/internet-users/slovakia/>
- [15] NASES (2015) Prieskum: *Spokojnosť s vybranými e-službami verejnej správy 2014 - Občania*. [Online], pp. 9-11. Available: <http://www.informatizacia.sk/782-menu/20299s>
- [16] NASES (2016) *The Central Government Portal*, 2016 [Online]. Available: <https://www.slovensko.sk/en/title>
- [17] WIRTZ, B. W., DAISER, P.: *E-Government: Strategy Process Instruments*, 1<sup>st</sup> ed., German University of Administrative Sciences, Speyer, 2015.

Karel Havel - Vojtech Balint - Andrej Novak\*

## A NUMBER OF CONFLICTS AT ROUTE INTERSECTIONS – RECTANGULAR MODEL

*A conflict is an infringement of minimum separation between at least two aircraft. Air traffic controllers build a protected area in front of an aircraft; its shapes and dimensions depend on the speed of an aircraft and on the minimum separation. The protected zone in this mathematical model is the horizontal rectangular zone. If an aircraft is inside this protected zone, a conflict occurs. The model is based on these assumptions: aircraft fly in level straight line routes; only an infringement of the lateral separation is considered; deviations are excluded; aircraft at the same flight level fly at the same average speed; aircraft fly towards an intersection and change direction after the intersection. Hence, conflicts mainly occur owing to the loss of minimum separation between aircraft flying at the same flight level. The calculation of average number of potential conflicts is designed for a long time interval; hence, aircraft velocity deviations are negligible. The mathematical model in this paper is intended to compare different alternative intersection configurations of air traffic service routes. The comparison is based on the following results: an average number of potential conflicts per hour at route intersections, index of conflict intensity, and intersection capacity.*

**Keywords:** Intersection configuration, aircraft conflicts, horizontal separation, protected zone.

### 1. Introduction

Air transport significantly contributes to the world economy development. Therefore, it is very important to sustain its further resilience, ensure effective, ecological activities and mainly ensure its safety.

In 2015, more than 3.5 billion passengers used scheduled air transport. When compared with 2014, the growth was 6.4%. The number of flights worldwide reached 34 million.

Based on the air traffic development the ICAO identified the Performance Based Navigation (PBN) as the main global priority. The ICAO concentrated as well on the PBN implementation at international airports during Continuous Descent Operations and Continuous Climb Operations. The SESAR AMAN and DMAN concepts, Free Route Airspace and growing air traffic require delineation of new routes [1].

All the above facts lead to the need of research of conflicts at route intersections in order to prevent them. The mathematical model presented in the paper “A number of conflicts at route intersections – a rectangular model” enables comparing different alternatives of intersection configuration of air traffic services routes. The comparison is based on the results: average number of potential conflicts per hour at route intersections, index of conflict intensity, and intersection

capacity. The results are intended to help choose the safest intersection configuration of routes.

The consequences of a particular conflicts depend on the design of item and the equipment in which it is install. Although the impairment in which the equipment is operated is sometimes an additional factor conflict consequences are primary inherent characteristic [2].

A conflict is an event in which two or more aircraft experience a loss of minimum separation. A conflict occurs when the distance between aircraft in flight violates a prescribed minimum, usually considered as 5 nautical miles (9 km) of horizontal and/or 1000 feet of vertical separation in radar environment [3]. These distances define an aircraft’s protected zone, a volume of airspace surrounding the aircraft which should not be infringed upon by any other aircraft.

Aircraft operating on cruising levels fly horizontal trajectories and are separated vertically, it follows that conflicts mainly occur owing to a loss of minimum separation between aircraft flying at the same flight level.

### 2. Model

A conflict situation in a radar environment occurs when the radar separation between aircraft is less than the prescribed

\* Karel Havel, Vojtech Balint, Andrej Novak

Faculty of Operation and Economics of Transport and Communications, University of Zilina, Slovakia  
E-mail: andrej.novak@fpedas.uniza.sk

minimum. However, air traffic controllers (ATCOs) build in front of an aircraft a protected zone, its dimensions depend on the speed of an aircraft and on the required minimum separation [4]. The protected zone, in this mathematical model, will be the rectangular zone; its dimensions are  $l$  which is a length of the protected zone and  $w$  which is a width of the protected zone. If an aircraft intrudes this protected zone a conflict occurs. Values  $l$  and  $w$  may be increased due to possible aircraft deviations from routes [5]. The mathematical model is intended to compare different alternatives of an intersection configuration. The assumptions and discussion above can be summed up as follows [6]:

1. Aircraft fly in level flight and at flight levels
2. Only infringement of the lateral separation is considered
3. Aircraft fly on the route which is a straight line, deviations are excluded
4. Aircraft at the same flight level fly at the same average speed
5. Longitudinal separation is always assured by ATC
6. Aircraft fly towards an intersection and change direction after the intersection.

### 2.1 Legend

We denote:

- $l$  - length of the protected zone,
  - $w$  - width of the protected zone,
  - $\bar{a}$  - aircraft on the route,  $APB$ ,
  - $\bar{b}$  - aircraft on the route,  $CPD$ ,
  - $\delta$  - angle of arrival at the intersection  $P$ ,
  - $\beta$  - oriented angle, means the change of direction of flight of aircraft  $\bar{b}$  in  $P$ ,
  - $\alpha$  - oriented angle, means the change of direction of flight of aircraft  $\bar{a}$  in  $P$ ,
  - $V$  - speed of both aircraft (constant and the same).
- The angles are *positive* if they are anticlockwise.

### 2.2 Deriving the Model

- We assume that aircraft  $\bar{b}$  is in point  $P$ . The suggested model will establish the position of aircraft  $\bar{a}$  in order to
- avoid conflict of  $\bar{a}$ ,  $\bar{b}$  in the particular moment
  - avoid conflict of  $\bar{a}$ ,  $\bar{b}$  in the past (assuming backward time shift),
  - avoid conflict of  $\bar{a}$ ,  $\bar{b}$  in the future (assuming forward time shift).

The model attempts to determine a critical zone in front of  $P$  (denoted  $LP$ ) and behind  $P$  (denoted  $PM$ ). Assuming aircraft  $\bar{a}$  avoids the critical zone and aircraft  $\bar{b}$  is in  $P$ , there is, was or will be no risk of conflict. However, if aircraft  $\bar{a}$  is in segment  $LP$  or  $PM$ , it will inevitably result in a conflict.

The whole situation is illustrated in Fig. 1. First, we will define critical zone *in front of*  $P$ .

If aircraft  $\bar{b}$  is in  $R$ , the protected zone front part of aircraft  $\bar{a}$  can be on the left of  $N$ , which is a perpendicular projection of  $R$  on  $AP$ . If we consider backward time shift of both aircraft so that  $\bar{b}$  is in  $P$ , the protected zone front part of aircraft  $\bar{a}$  is in a such point  $U$  left of  $N$  that  $|UN| = |RP|$ . Therefore, aircraft  $\bar{a}$  must be in  $L$  left of  $U$  and  $|LU| = l$ .

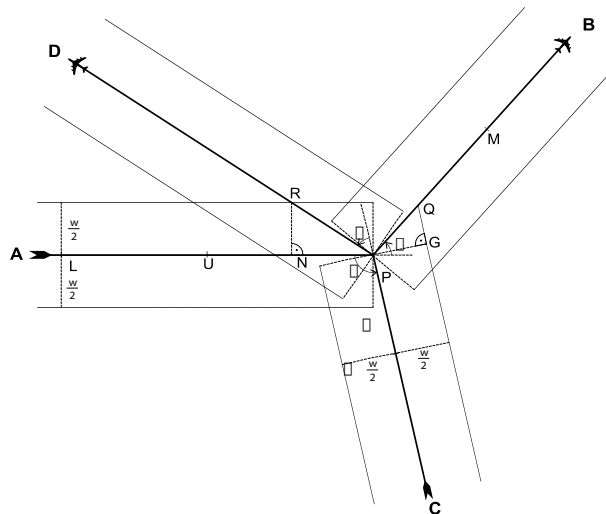

Fig. 1 Intersection

From the triangle  $PNR$  follows that angle  $\angle NPR = \pi - \delta - \beta$ , and therefore

$$|RP| = \frac{w}{2} \cdot \frac{1}{\sin(\pi - \delta - \beta)} = \frac{w}{2} \cdot \frac{1}{\sin(\delta + \beta)} \text{ and}$$

$$|NP| = \frac{w}{2} \cdot \cot g(\pi - \delta - \beta) = -\frac{w}{2} \cdot \cot g(\delta + \beta).$$

Hence

$$\begin{aligned} |LP| &= |LU| + |UN| + |NP| = l + \frac{w}{2} \cdot \frac{1}{\sin(\delta + \beta)} - \\ &- \frac{w}{2} \cdot \cot g(\delta + \beta) = l + \frac{w}{2} \cdot \frac{1 - \cos(\delta + \beta)}{\sin(\delta + \beta)} = \\ &= l + \frac{w}{2} \cdot \operatorname{tg} \frac{\delta + \beta}{2}. \end{aligned}$$

Let us find the critical zone *behind* point  $P$ . If the protected zone front part of aircraft  $\bar{b}$  is in  $Q$ , i.e. the distance between  $\bar{b}$  and  $P$  is  $l - |QG|$ , aircraft  $\bar{a}$  must be right of  $Q$ . Assuming the forward time shift, aircraft  $\bar{b}$  will be in  $P$ , aircraft  $\bar{a}$  must be in such  $M$  that  $|QM| = l - |QG|$ .

In the right-angled triangle  $QGP$  angle

$$\angle QGP = \frac{\pi}{2} + \alpha - \delta, \text{ therefore}$$

$$|QG| = \frac{w}{2} \cdot \operatorname{tg}\left(\frac{\pi}{2} + \alpha - \delta\right) = -\frac{w}{2} \cdot \operatorname{cotg}(\alpha - \delta);$$

$$|PQ| = \frac{w}{2} \cdot \frac{1}{\cos\left(\frac{\pi}{2} + \alpha - \delta\right)} = -\frac{w}{2} \cdot \frac{1}{\sin(\alpha - \delta)}.$$

Hence

$$\begin{aligned} |PM| &= |PQ| + |QM| = |PQ| + l - |QG| = \\ &= -\frac{w}{2} \cdot \frac{1}{\sin(\alpha - \delta)} + l + \frac{w}{2} \cdot \operatorname{cotg}(\alpha - \delta) = \\ &= l + \frac{w}{2} \cdot \frac{1 - \cos(\alpha - \delta)}{\sin(\alpha - \delta)} = l - \frac{w}{2} \cdot \operatorname{tg} \frac{\alpha - \delta}{2} = \\ &= l + \frac{w}{2} \operatorname{tg} \frac{\delta - \alpha}{2}. \end{aligned}$$

Thus the length of the critical zone is

$$\begin{aligned} |LM| &= |LP| + |PM| = l + \frac{w}{2} \cdot \operatorname{tg} \frac{\delta + \beta}{2} + l + \\ &+ \frac{w}{2} \cdot \operatorname{tg} \frac{\delta - \alpha}{2} = 2l + \frac{w}{2} \cdot \left( \operatorname{tg} \frac{\delta + \beta}{2} + \operatorname{tg} \frac{\delta - \alpha}{2} \right). \end{aligned}$$

### 2.3 Average number of potential conflicts per hour

If the average speed of both aircraft is  $V$ , the time of flight on  $LM$  is  $LM/V$ .

Let us denote:

$f_1$  - average traffic flow on  $APB$ ,

$f_2$  - average traffic flow on  $CPD$ .

Hence, the average occupancy time  $T$  of aircraft from flow  $f_1$  on segment  $LM$  is

$$T = \frac{f_1 LM}{V} = \frac{f_1}{V} \left( 2l + \frac{w}{2} \left( \operatorname{tg} \frac{\delta - \alpha}{2} + \operatorname{tg} \frac{\delta + \beta}{2} \right) \right).$$

During the time  $T$  we can expect  $Tf_2$  aircraft from the flow  $f_2$ . This value  $Tf_2$  is obviously an average number  $E$  of potential conflicts per hour

$$E = Tf_2 = \frac{f_1 f_2}{V} \left( 2l + \frac{w}{2} \left( \operatorname{tg} \frac{\delta - \alpha}{2} + \operatorname{tg} \frac{\delta + \beta}{2} \right) \right).$$

#### INDEX OF CONFLICT INTENSITY

It describes the intersection  $I$  without the influence of traffic flows

$$I = \frac{E}{f_1 f_2} = \frac{1}{V} \left( 2l + \frac{w}{2} \left( \operatorname{tg} \frac{\delta - \alpha}{2} + \operatorname{tg} \frac{\delta + \beta}{2} \right) \right).$$

#### CAPACITY OF INTERSECTION

The equation above can be modified to the following expression

$$f_1 f_2 = \frac{EV}{2l + \frac{w}{2} \left( \operatorname{tg} \frac{\delta - \alpha}{2} + \operatorname{tg} \frac{\delta + \beta}{2} \right)}.$$

### 3. Conclusion

The mathematical model is designed to compare different alternatives of intersection configuration. The evaluation and comparison is based on an average number of potential conflicts per hour, index of conflict intensity, capacity of intersection. Calculation of average number of potential conflicts is designed for a long time interval; hence aircraft velocity deviations are negligible. Average number of potential conflicts per hour depends mainly on average traffic flows on routes. Decisive for index of conflict intensity are rectangular zone dimensions. The number  $f_1 f_2$  is a capacity of intersection for a given number of potential conflicts per hour and it mainly depends on an intersection configuration.

#### Acknowledgement

This paper is published as one of the scientific outputs of the project: „Centre of Excellence for Air Transport ITMS 26220120065“.

### References

- [1] ICAO - Air Navigation Report, Capacity & Efficiency, 2016.
- [2] BUGAJ, M., NOVAK, A., BENO, L.: Application of RCM Principles in the Air Operations. *Communications - Scientific Letters of the University of Zilina*, No. 2, 2005, 20-62, ISSN 1335-4205.
- [3] ICAO Doc 4444 - Air Traffic Management, 15<sup>th</sup> edition - Code 7700.
- [4] HAVEL, K., et al.: *Air Traffic Control*, Praha : Nadas, 1990, ISBN 80-7030-056-6.
- [5] BADANIK, B., BARTOS, M.: Innovative Approach in Provision of Air Navigation Services in Europe, *Zilinska univerzita : Zilina*, 2016, 24-27, ISBN 978-80-554-1252-8.
- [6] HAVEL, K., HUSARCIK, J.: A Theory of the Tactical Conflict Prediction of a Pair of Aircraft, *J. of Navigation*, vol. 42, No. 3, 417-429, 1989, ISSN 0373-4633.

Zuzana Juchova Juroskova - Boris Bucko\*

---

## USER ORIENTED APPROACH IN INFORMATION COMMUNICATION TECHNOLOGY RESEARCH

*User-oriented approach is changing the way of information systems development and affects the processes, methodologies and paradigms proposed by software architects and developers. In line with that trend we carried out two separate studies where the users were involved in the whole process of the development. The first study used experiment, data mining and text mining and was focused on identifying opportunities for obtaining values of bibliographic elements to digitize objects in order to maximize the quality and quantity of delivering meta-data value elements of physical objects Slovak library database from a user's perspective. The second study used experiment and was focused on the design of the architectural framework for information system solutions for knowledge management in the organization by using the principles of model-driven architecture (MDA) and ontology modeling language within the CIM (Computer Independent Model) and PIM (Platform Independent Model) levels.*

**Keywords:** Database, text mining, datamining, ontology, Computer Independent Model, Platform Independent Model.

### 1. Introduction

Information society has changed significantly recently. While a few years ago it was difficult to gain access to the information, today we are overwhelmed with information and we are trying to find the best ways of how to organize, search, process, store, represent and use Big Data. We develop new technologies and procedures for data mining, we improve predictive analytics, we create new jobs (external and internal algorithm analytics) and we also set up new types of organizations (i.e. data mediators). The only thing that has not changed significantly is the way how users search information. We can assume that users search information using keyword(s). Interpretation of search results contents and type of its representation influence the popularity and reusability of the specific tool or service.

Database systems and information systems can be considered as the one of the most frequently used information environments. The development of database and information systems has a long history. Software architects and developers tend to use various approaches, methodologies and paradigms in order to implement innovative solutions. The creation of web sites (containing databases and information systems) based solely on the opinions and proposals of the application developers proved to be insufficient. Jacob Nielsen [1] states that estimates of user behavior are wrong up to 75%, which

results into significant changes towards traditional approaches and puts emphasis on user requirements. The quality of the proposals and selected procedures is thus subject of user testing. Nowadays user testing has become usual part of development of the databases and information systems.

For this reason, it appears to be necessary to develop flexible and easy to maintain databases and information systems that can meet the requirements of users in the shortest possible time. In line with this trend - focusing on user requirements and meeting their needs we have carried out two separate studies.

### 2. User oriented approach

These studies used various methods to acquire input data:

- Analysis,
- Synthesis,
- Questionnaire method,
- Group discussions.

and also methods for data processing:

- Experiment,
- Data mining,
- Text mining.

---

\* Zuzana Juchova Juroskova, Boris Bucko  
University Science Park, University of Zilina, Slovakia  
E-mail: zuzana.juchova@uvp.uniza.sk

## 2.1 Study 1

The key source of information for final theses (bachelor, master or PhD) and also for degree theses (rigorous and habilitation) are still libraries which offer databases of printed and electronic objects. These objects can be obtained through online catalogs OPAC (online public access catalog). These databases contain a large number of elements of different metadata schemas describing physical objects. The number of these objects is increasing in the process of mass digitization of database objects which include elements of digitalized objects description. In 2012 the Slovak National Library began mass digitization of object. Within this digitization each digital object contained at least two elements:

- Persistent identifier,
- Metadata Dublin Core.

Project "Digital library" calculates with the usage of qualified Dublin Core format and also with complete MARC21 record which is transformed for digital repository using MODS with all descriptive metadata [2]. It should be noted that metadata elements forming part of digital libraries are primarily intended for the user but are also used to describe web pages, documents, etc. to make the search much easier.

There was used a traditional approach to transform repository in the Slovak National Library - proposal and implementation was done mostly by internal employees of the ICT (information communication technologies) department. During the 12th Annual Conference for Librarians called "The function of libraries under the changed economic conditions and the specific user requirements during the economic crisis" [3] there was discussed disappointment and user unpopularity over the current online library catalog. According to this opinion we tried to investigate the cause of the mentioned problem. The research was conducted by one author as a part of her dissertation thesis [4] *the aim of which was to identify possibilities for obtaining bibliographic elements values during the objects digitization with an aim to maximize the quality and the quantity of delivered metadata elements values of physical objects within Slovak database library. And this should be done from a user perspective.*

Given that the use of online catalog was standardized and established in accordance with applicable standards and recommendations we focused on a content analysis of search results and used the user approach to solve this problem. That is why we focused on acquisition of the most desirable bibliographic elements. We also focused on identifying accessible bibliographic elements provided within specific object records in Slovak library which are actually used by the user during the object decision-making process. Afterwards we determined multiplicity of the users most desirable filled metadata elements of the objects from the Slovak library online database. From the original size of the statistical series

4 203 474 records we were able to generate 119 858 records of text documents from ORACLE database system. These text documents also had filled in the most desirable element - element containing keywords.

The results of the initial analysis showed that the real number of relevant values of the most desired metadata elements provided by a database is only 1.36. According to the total number of records in the databases of the Slovak library we have judged this multiplicity as unsatisfactory, because the user is not able to make decision based on available metadata elements. It is not clear which object is subjectively relevant for the user, which is the major issue in the process of meeting information needs of the user. The size of text documents and the number of pages were the main criteria to identify the most suitable method to supplement existing Slovak library database on a generated metadata element values. These values were necessary to create a new digital library database with text mining method and as criteria of deliberate choice of the text documents were used:

- Condition 1 - filling field 650 - Topical term
- Condition 2 - the necessity of the existence and availability of digital copies of these objects. the need to obtain.

Afterward these generated objects were:

1. Converted to plain text - to get rid of formatting and to prevent language encoding errors within Slovak language.
2. Each object was processed separately in the Rapid Miner software. By assigning the weights to each term we were able to get list of terms represented by chosen vector. Using TF-IDF option we were able to create vector based on the frequency and the reversed frequency of the occurrence of terms (words) in the document [5]. The removal of stop words or edit words to the basic form were not used because these options are not available for texts written in the Slovak language.
3. After the generation of terms, we ignored the conjunctions, prepositions, etc.

The generated keywords were compared with actual values from metadata database elements from Slovak library. We identified a percentage of their conformity. The final match was 77.14% which means that with a probability of 77.14% the generated keyword also has a tag value 650 - Topical term in Slovakia library database.

## 2.2 Study 2

The complexity of information systems (IS) is constantly increasing. This trend is apparent not only from the technological possibilities but also from the performance requirements that are placed on information system functionality. Functional requirements are based on the

new requirements of the users. Because the user is the one who is the information system developed for. However, it is only in those cases where the requirements of the users are correctly processed by business or system analysts and then translated into the functional specifications of IS. If user requirements are not processed properly, it may result into information system which does not meet the needs of organizations and further system modification and maintenance is difficult and costly. Nowadays it is not possible to focus only on functionality of information system without any deeper knowledge of organization's structure and needs. Linking business perspective and the perspective of a specific information system is therefore still an interesting field of research.

Applying the principles of the ISO / IEC / IEEE 42010: 2011 Standard, the developers are trying to get rid of problems that come with object oriented IS development by establishing connection between business perspective and software perspective in the system architecture [6]. These views form two partial architectures - the business architecture and the software architecture. Each of the partial architectures has different language to describe architecture. Languages for perspective/view description are today the mostly represented as graphical models and model-driven development becomes a fundamental principle or a paradigm of IS development.

Model Driven Architecture (MDA) is based on creation of models and transformations between these models. MDA specifies four levels of abstraction:

1. Computation Independent Model - CIM
2. Platform Independent Model - PIM
3. Platform Specific Model - PSM
4. Implementation Model - IM

Levels of abstraction mentioned above are fundamental paradigm of MDA. The first three levels are graphical models and the last level one is made of source code.

Models of different levels can be gradually transformed to the source code and vice versa - the changes in source code can be applied back in the models using inverse MDA. This simplifies not only the development but also the maintenance of such created information systems. Transformational links between models and source code enable to keep the models, source code, files and documentation in a consistent state. Transformations between levels are an important aspect of MDA. There is a continuous effort to semi-automate these transformations, or if it is possible to completely automate this process. With regards to the type of the MDA it is necessary to create transformation rules between source and target model. In the terms of the application of Object-Oriented Systems Analysis and Design - OOSAD during the IS proposal, the greatest emphasis is put on the PIM - PSM transformation in both directions. Nowadays, there are various CASE tools and the MDA tools that enable transformations. Top level (CIM)

to a lower level (PIM) transformations are still not described in the OMG documents. Only partial results of solving the problem are available [7 - 10].

Within our proposed solutions, we decided to use ontology. Ontology as a tool for developing IS is currently used in different contexts and stages which can be seen in various scientific articles [11 - 14].

Most systems do not fail for technical reasons but because they do not address the real needs of the customers. The lack of the focus in the analytical stages represented by the CIM level (within MDA) only postpones real IS development problems. These problems can later occur during the implementation and during the maintenance of information systems. Organizations need to use information technology to support specific processes. Create support for these processes is not an easy task which cannot be done by configuring ready-made software package. That is why it is usually necessary to create tailor made system which can meet user requirements. Specific processes need to be logically linked to data, information and knowledge through the implementation of knowledge management.

According to the information mentioned above we set the objective to: *Design an architectural framework for information system solutions for knowledge management in the organization by using the principles of model-driven architecture (MDA) and ontology as a modeling language in the levels of CIM (Computer Independent Model) and PIM (Platform Independent Model)*. Research was conducted by one author as a part of his dissertation thesis [15]. To achieve that objective, we divided it to the 4 partial objectives:

1. The use of ontologies in the IS development leads to new discipline - ontological engineering. Ontological engineering is mostly associated with knowledge engineering. If we consider MDA as the IS development principle - the first partial objective of the solution is to integrate the principles of MDA into ontology and knowledge engineering.
2. The general development of the IS according to principles of the ISO / IEC / IEEE 42010: 2011 standard - Systems and Software Engineering leads to the creation of an architectural framework that forms the methodology of the software-intensive systems development. Creation of an architectural framework for the development of knowledge-based systems using ontologies with the emphasis on the modeling of CIM and PIM level is the second partial objective.
3. It is necessary to confirm the theoretical solution. Therefore, application of the created architectural framework within specific domain with experimental verification of the analysis and design of IS is the third partial objective.
4. The use of ontology as a modeling tool in MDA can remove the transformations between CIM and PIM levels. Validate and confirm the use of ontologies over other modeling

languages in model driven architecture is the fourth partial objective.

### 3. Results and discussion

In the terms of study 1 which was based on user-oriented digitization process and with the usage of the ultimate algorithm we were able to generate keywords with 77.17% success rate. These keywords are requested by the users. In the case of real usage of the proposed approach within Slovak library we recommend to semi-automate the process - employee of the library should select only those keywords which are in accordance with the methodology to value creation of metadata elements. To fully automate this process, it would be possible to use algorithm made by specialists in the field of library and information science. This algorithm could use controlled vocabularies, thesaurus, word weighting, etc. Further research could examine various options of search results representation which could simplify the decision making process within choosing the right object from searched records set.

According to study 2 we can assume that ontology can be mapped to the model independent on the computer processing (CIM) and also on a Platform Independent Model (PIM). Consequently, it is possible to view these models in graphical form - as a business processes in BPMN notation or use cases in UML notation. Using this concept, it is possible to speed up the modeling process and also eliminate the need for transformation between CIM and PIM levels. In order to fully eliminate the need for transformation the mapping has to be extended to the whole scope of the CIM and PIM levels modeling in the respect of notation, restrictions, conventions, standards and file types. Nevertheless, the proposed solution is able to consolidate, clarify and accelerate the design, creation and maintenance of business processes and use case diagrams in terms of CIM / PIM transformations and provides a platform for further development in this research area. The advantage of the proposed solution is that the manual creation of the transformations between CIM and PIM levels is no longer necessary since all information from these levels are united under a single ontology. CIM and PIM levels can be generated directly from the ontology. Any changes made during the design phase of the IS are edited directly in the ontology and will be then reflected in the CIM/PIM models which are generated from this ontology.

### 4. Conclusion

The approach to generate values of the most desirable metadata elements for adding new digital library database is considered by us as a ready-to-implement solution even without implementing the recommendations listed in the Results and discussion, as we agree with the Big Data specialist opinion: "Rather to have a lot of worse data than a small amount of better data" [16].

According to our studies - we have confirmed that experts without satisfying user needs are not able to create or modify high quality information system. Users enter the development process more often than we could think. Users test even the partial results and their requirements shape every aspect of IS development. Due to this fact it is important that the user with his/her requirements has to be perceived as the basic prerequisites for the creation of IS.

Model-driven development which includes model driven architecture allows to divide analysis, design and implementation of IS to individual models and levels which abstract the complexity of the IS into the smaller, transparent units. These units are easy to maintain and allow to clearly define the actual stage of the IS development.

To ensure that the models will share information it is necessary to create interoperability between MDA levels. This interoperability is provided by model transformations which are usually made manually. The principle of using ontology as a modeling language in the model driven architecture enables to automate model creation and also eliminates the need to manually transform models within the various levels of abstraction.

### Acknowledgements

This paper is supported by the following project: University Science Park of the University of Zilina (ITMS: 26220220184) supported by the Research&Development Operational Program funded by the European Regional Development Fund.



## References

- [1] NIELSEN, et al.: *Evidence-Based User Experience Research, Training, and Consulting*. [Online]. Available: <https://www.nngroup.com/topic/research-methods/?page=2>. [Accessed 19 10 2016].
- [2] JUCHOVA JUROSKOVA, Z., ZAVODSKA, A.: *Using of Text Mining in Online Public Access Catalog*. Uden, L., et al. (Eds.): KMO 2015, LNBIP 224, pp. 451-462. Springer, Heidelberg (2015).
- [3] Statna vedecka kniznica v Banskej Bystrici.: 12<sup>th</sup> annual Conference for librarians, [Online]. Available: <http://www.svkbb.eu/aktualne-informacie/716-fungovanie-kninic-v-zmenenych-ekonomickych-podmienkach-a-pecificke-poia>. [Accessed 01 10 2016].
- [4] JUCHOVA JUROSKOVA, Z.: *The Measurement of Information about Cultural Heritage*. [PhD. thesis], University of Zilina, p. 102 (2012).
- [5] ROBERTSON, S.: *Understanding Inverse Document Frequency: On Theoretical Arguments for IDF*. J. Documentation 60(5), 503-520 (2004). [Online]. Available: <http://www.emeraldinsight.com/doi/full/10.1108/00220410410560582>. [Accessed 06 10 2016].
- [6] ISO/IEC/IEEE 42010:2011. 2011, Systems and software engineering - Architecture description.
- [7] SURYN, W., KHERRAF, S., LEFEBVRE, E.: Transformation from CIM to PIM Using Patterns and Archetypes. *Software Engineering Conference, Australian*, 2008, 338-346.
- [8] RODRIGUEZ, A., FERNANDEZ-MEDINA, E., PIATTINI, M.: *CIM to PIM Transformation: A Reality*. IFIP, vol. 255, Research and Practical Issues of Enterprise Information Systems II, vol. 2, 1239-1249. Springer : Boston, 2008.
- [9] ZHANG, W., MEI, H., ZHAO, H., YANG, J.: Transformation from CIM to PIM: A Feature Oriented Component-Based Approach. *Model Driven Engineering Languages and Systems*, vol. 3713, 248-263. Springer (2005).
- [10] CAO, X.-X., MIAO, H.-K., XU, Q.-G.: *Modeling and Refining the Service-Oriented Requirement*. 6<sup>th</sup> intern. symposium on Theoretical Aspects of Software Engineering, 2008, 159-165. TASE'08. 2<sup>nd</sup> IFIP/IEEE International Symposium on. IEEE (2008).
- [11] KANG, D., et al.: An Ontology-Based Enterprise Architecture. *Expert Systems with Applications*, 2010, 37.2: 1456-1464.
- [12] HICKEY, A. M., DAVIS, A. M.: An Ontological Approach to Requirements Elicitation Technique Selection. *Ontologies*, 2007, 403-431, Springer.
- [13] VONGDOIWANG, W., BATANOV, D. N.: An Ontology-Based Procedure for Generating Object Model from Text Description. *Knowledge and Information Systems*, 2006, 10.1: 93-108.
- [14] VARGAS-VERA, M., et al.: MnM: Semi-Automatic Ontology Population from Text. *Ontologies*, 373-402, 2007, Springer.
- [15] BUCKO, B.: *Model Driven Architecture and Ontologies* [PhD. thesis]. University of Zilina : Zilina, SR, 2016, p. 107.
- [16] MAYER-SCHONBERGER, V., CUKIER, K.: *Big Data: A Revolution that will Transform How we Live, Work and Think*, Hodder&Stoughton, 2013, p. 256.

Katarina Zgutova - Miroslav Neslusan - Juraj Sramek - Peter Danisovic - Jiri Capek\*

## MONITORING OF SURFACE DAMAGE IN RAILS AFTER LONG TERM CYCLIC LOADING

*This paper reports about possible concept in which surface damage of the rail after long term cyclic loading can be executed. This study employs non destructive magnetic Barkhausen noise as a promising technique which exhibits very good sensitivity against extent of surface damage. Magnetic Barkhausen noise is correlated with the conventional parameters of surface integrity expressed in term of the thickness of damaged layer, its micro hardness as well as stress state. Furthermore, phase analysis of the real surface indicates that extensive phase transformations are produced by the repeated severe plastic deformation. Phase composition of the damaged layer indicates that structure transformation in the rail surface is thermally induced rather than deformation induced process.*

**Keywords:** Plastic deformation, non destructive evaluation, phase transformation.

### 1. Introduction

Large axle loads of the trains usually cause serious wear and structure transformations of the rails. Near surface region of the rail surface appears white under the metallographic observation [1 - 3]. For this reason this region is named white etching layer (WEL). Origin of WEL was widely discussed. Newcomb and Stobbs reported that WEL is initiated by the repetitive and severe plastic deformation [4]. On the other hand, phase analyses reveal retained austenite which indicates that WEL is thermally initiated process when the near surface region undergoes heating above austenitizing temperature followed by rapid self - cooling [1 - 3 and 5]. Such process hinders full transformation of austenite to pearlite and certain volume of austenite retains in the WEL. WEL was subjected to many studies in which variable techniques were employed to identify stress state, phase composition, chemical and other alterations [1 - 5]. It was reported [1] that WEL is a product of rolling-contact fatigue caused by the alternating stresses associated with rolling contact bodies. Operation of the rails containing WEL regions may be risky with the respect to possible rails macro cracking initiated by micro cracks in the WEL. Furthermore, rails are subjected to grinding process in order to remove damaged layer and surface asperities [3].

For these reasons the suitable non destructive method would be beneficial to revelation of the surface damage

degree. Magnetic Barkhausen noise (MBN) is sensitive to microstructure and stress state [6 - 11]. Being so, this study deals with sensitivity of MBN technique for such purpose. MBN originates from irreversible and discontinuous Bloch Walls (BW) motion during the cyclic magnetization. The main reason can be viewed in pinning strength of variable microstructure features interfering with BW in motion. Irreversible and discontinuous BW motion produces acoustic as well as electromagnetic pulses. Electromagnetic pulses propagate towards free surface and can be detected by the use of a suitable pick up coil. It is well known that MBN is a function of stress state as well as microstructure. However, stress state affects mainly the domain and corresponding BW alignment whereas microstructure affects the free path of BW motion [7]. Microstructure of matrix can be expressed in many terms and it is worth to mention that BW interferes with all crystalline defects. Being so, in many studies MBN is studied as a function of dislocation density [9], carbides precipitation [10], grain size or presence of non ferromagnetic phases [7]. Transformations in WEL are very complex and fully change character of the matrix. Being so, MBN could be a promising technique for monitoring of surface state of rails in operation. This pilot study reports about monitoring of surface damage in the rail by the use of MBN.

\* <sup>1</sup>Katarina Zgutova, <sup>2</sup>Miroslav Neslusan, <sup>1</sup>Juraj Sramek, <sup>1</sup>Peter Danisovic, <sup>3</sup>Jiri Capek

<sup>1</sup>Faculty of Civil Engineering, University of Zilina, Slovakia

<sup>2</sup>Faculty of Mechanical Engineering, University of Zilina, Slovakia

<sup>3</sup>Faculty of Nuclear Science and Physical Engineering, CVUT Praha, Czech Republic

E-mail: katarina.zgutova@fstav.uniza.sk

## 2. Experimental part

The experimental study was carried out on hot rolled rail steel R220 (strength  $785 \pm 50$  MPa, hardness  $215 \pm 35$  HB) of chemical composition indicated in Table 1.

Chemical composition of the rail steel R220 in wt %. Table 1

| Fe   | C    | Mn   | Si   | Cr   | Ni   | Cu   | P    |
|------|------|------|------|------|------|------|------|
| bal. | 0.60 | 1.05 | 0.21 | 0.12 | 0.13 | 0.07 | 0.02 |

The rail was subjected to the 20 years accumulated passing tonnage about 0.8 million tons per year. Figure 1 shows a photo of the rail profile with indication of the analyzed zone. The rail surface was measured and analyzed within the whole rail width in which the possible contact of the rail and wheel can be expected. Metallographic observation, micro hardness alterations, XRD and MBN measurements were carried in certain points regularly distributed within the rail width (distance between the neighboring points is kept 6 mm).

MBN was measured by the use of RollScan 350 and software  $\mu$ Scan 500 (magnetizing voltage 5 V, magnetizing frequency 125 Hz, 10 bursts, sensor type S1-18-12-01, frequency range of MBN from 10 to 1000 kHz). MBN values were obtained by averaging 10 MBN bursts (5 magnetizing cycles). MBN refers to the rms (effective) value of the signal. Estimated sensing depth of the MBN signal is about  $50 \mu\text{m}$ . Magnetization of the rail surface was carried out in the direction of traction.

Residual stresses and phase analysis were measured via X-ray diffraction technique (XRD) ([211],  $\alpha$ -Fe, CrK $\alpha$ , 40kV, 30mA, average sensing depth approx.  $5 \mu\text{m}$ , X'Pert PRO). Except stress state also Full Width at Half Maximum (FWHM) was analyzed since this parameter is closely connected with micro hardness of the matrix.

To reveal the microstructure transformations induced by severe plastic deformation 10 mm long pieces were routinely prepared for metallographic observations (etched by 3% Nital for 8s). Microstructure was observed in the direction longitudinal with the track direction.

Vickers micro hardness readings were conducted by Zwick Roel ZHm micro-hardness tester by applying the force 50g for 10 seconds. Micro hardness was determined by averaging 3 repetitive measurements (3 micro hardness profiles spaced 0.1 mm).

All measurements were conducted at 7 points within the rail surface region indicated in Fig. 1. The first position was placed 3 mm from the left side. The following positions were spaced 6 mm each to other (also bulk structure was investigated).

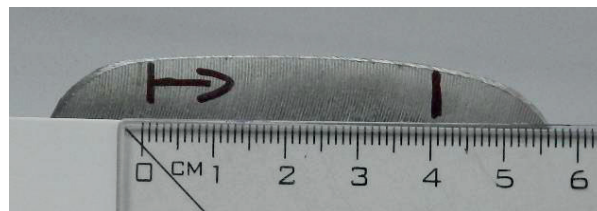

Fig. 1 The rail cross section with indication of measured width

## 3. Results of experiments

Figure 2 illustrates the bulk structure as well as rail surfaces. Bulk is composed of pearlite with the equiaxed grains. On the other hand, the sub surface regions exhibit preferential orientation of the pearlite matrix due to hot rolling process. WEL is superimposed on this preferentially oriented matrix. Figure 3 also depicts that thickness of WEL varies within the investigated rail width. Thin and discontinuous WEL can be found on the left side of the rail width (distance 3 mm) whereas thick and continuous WEL is located at the distance 9 and especially 15 mm from the left side of the rail. Distances 21 and 27 mm also exhibit thin and discontinuous WEL whereas positions 33 and 39 mm indicate no WEL in the surface region.

It can be easily understood that the main rail load is positioned in the zones of thick and continuous WEL. Micrographs also indicate that the rail surface is polluted by the long term oxidation. Oxides initiated on the rail free surface contaminate not only WEL region but the whole rail width and process of plastic deformation dips oxides into the deeper layer beneath the free surface. Micrographs also reveal surface cracking since WEL regions become hard and brittle. Further loading of such structure together with oxidizes initiate micro cracking contributing to the remarkable irregularities in the rail surface profile.

Surface oxidation can be verified by phase analyses executed by the use of XRD technique. Table 2 indicates that all regions contain  $\text{Fe}_2\text{O}_3$  and first 3 regions also FeO. Table 2 also shows that bulk structure is entirely composed of pearlite phase. On the other hand, thick WEL regions contain martensite matrix of high tetragonality mixed with retained austenite whereas the right side of the rail width is composed of ferrite (low degree of lattice tetragonality) without retained austenite. Phase analysis verifies that WEL is thermally induced structure since retained austenite indicates that the near surface region undergoes heating above the austenitizing temperature. Table 2 also indicates that original pearlite structure is completely decomposed. Cementite lamellas are broken into very fine particles and certain volume of carbon is dissolved in the matrix [2 and 5].

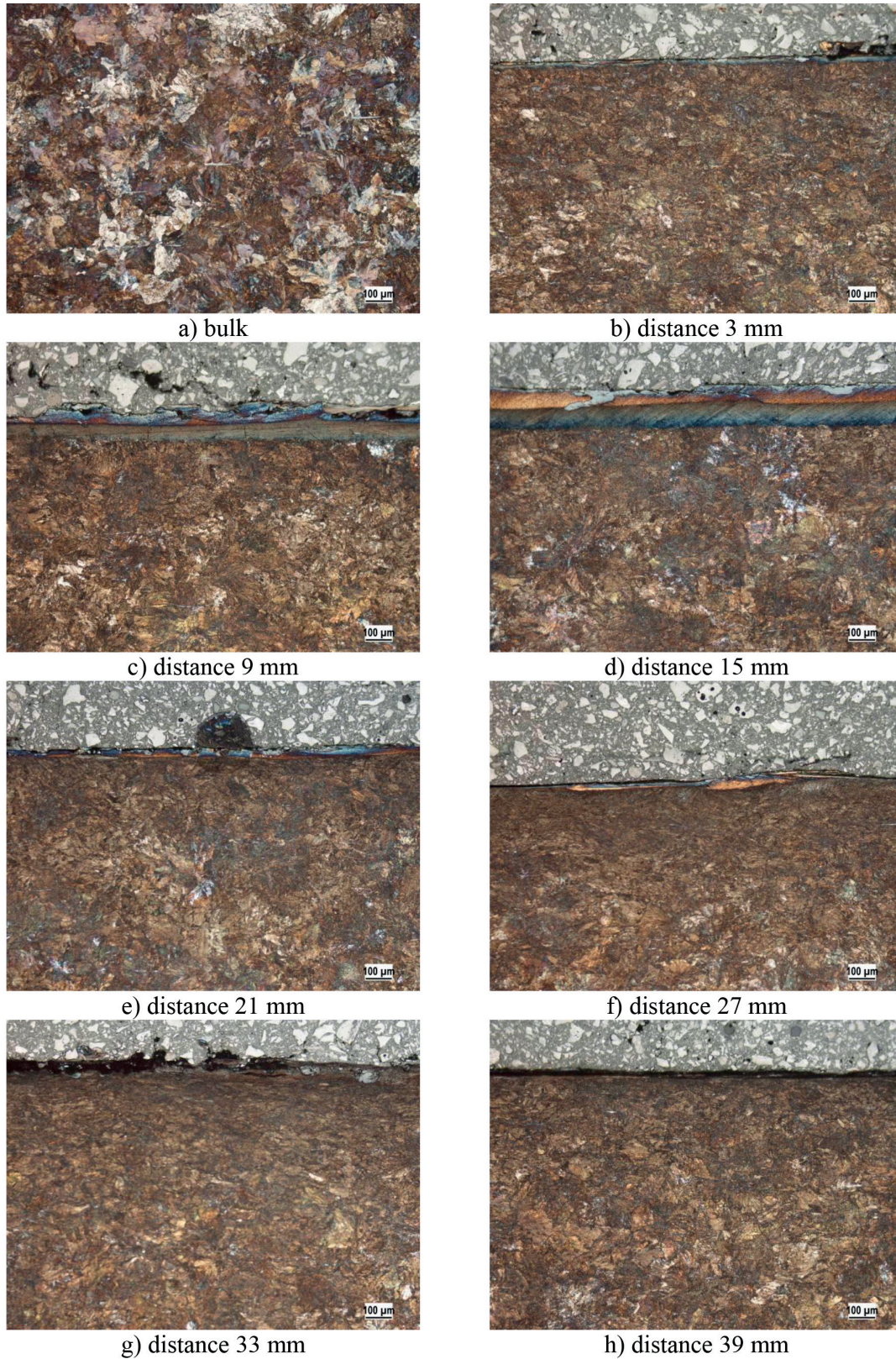

Fig. 2 Metallographic observation of the rail surface + bulk

Phases on the rail surface indicated by XRD technique

Table 2

| dis. (mm) | Fe $\alpha$ | Fe $\gamma$ | Fe <sub>3</sub> C | Fe <sub>2</sub> O <sub>3</sub> | FeO | C | Fe fct         |
|-----------|-------------|-------------|-------------------|--------------------------------|-----|---|----------------|
| 3         | -           | ●           | -                 | ●                              | ●   | ● | ● <sup>+</sup> |
| 9         | -           | ●           | -                 | ●                              | ●   | ● | ● <sup>+</sup> |
| 15        | -           | ●           | -                 | ●                              | ●   | ● | ● <sup>+</sup> |
| 21        | -           | -           | -                 | ●                              | -   | ● | ● <sup>+</sup> |
| 27        | -           | -           | -                 | ●                              | -   | ● | ●              |
| 33        | -           | -           | -                 | ●                              | -   | ● | ●              |
| 39        | -           | -           | -                 | ●                              | -   | ● | ●              |
| bulk      | ●           | -           | ●                 | -                              | -   | - | -              |

●<sup>+</sup> - high degree of lattice tetragonality  
 ● - low degree of lattice tetragonality

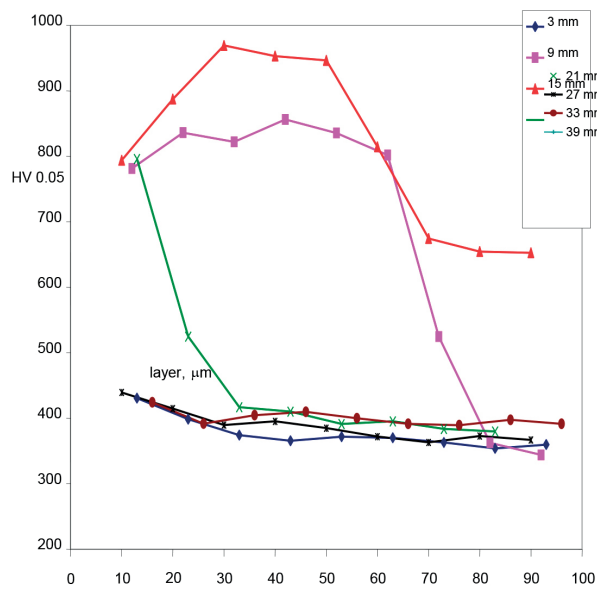

Fig. 3 Micro hardness profiles

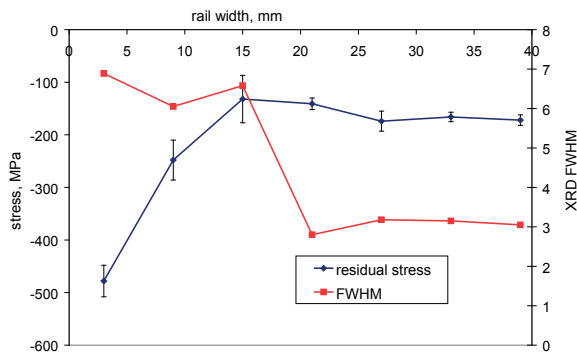

Fig. 4 Residual stresses and FWHM (XRD)

High hardness of the WEL corresponds with the high tetragonality of matrix (see Table 2) and associated dislocation density. Such matrix is produced due to rapid self-cooling from austenitizing temperature and results into remarkable surface hardening [1 - 2 and 5]. Thick and continuous WEL corresponds with quite deep extent of high hardness for distances 9 and especially 15 mm. On the other hand, it is worth to mention that micro hardness profiles for distances 3, 21 and 27 mm are debatable since WELs in these areas are discontinuous; they can occur in the form of localized spots thus indentation results can remarkably vary in the near surface region.

As it was expected, compressive stresses can be found within the whole rail width. The left side exhibits higher magnitude of compressive stresses compared to the rest of the rail surface. Figure 4, Table 3 and Fig. 5 show poor sensitivity of residual stresses against the thickness of WEL since the thick WEL gives nearly the same stresses as the regions containing thin discontinuous WEL or regions free of WEL, see Fig. 4. The main reasons can be found as follows:

- sensing depth of XRD technique is too low (about 5 μm) compared with thickness of WEL; thus stress state can not distinguish between thin and thick WEL,
- surface cracking releases the stresses in the WEL and other regions,
- due to long term cyclic loading WEL region undergoes repetitive periods of surface hardening followed by the matrix dynamic recovery and the corresponding stress relaxation [2].

On the other hand, FWHM is more sensitive to the structure alterations; thus regions containing thick WEL exhibit high values of FWHM a vice versa, see Fig. 4, Table 2 and Fig. 6. High values of FWHM correspond with high hardness and associated high dislocation density. Compared to the stress state, relationship between WEL thickness and FWHM exhibits better correlation (expressed in term R<sup>2</sup>), see Fig. 6.

MBN (rms) and thickness of WEL

Table 3

|         | 3 mm  | 9 mm   | 15 mm  | 21 mm  | 27 mm  | 33 mm | 39 mm  |
|---------|-------|--------|--------|--------|--------|-------|--------|
| MBN, mV | 389±8 | 223±8  | 144±15 | 390±15 | 334±12 | 303±9 | 315±14 |
| WEL, μm | 29±29 | 111±22 | 152±55 | 22±22  | 44±44  | 0     | 0      |

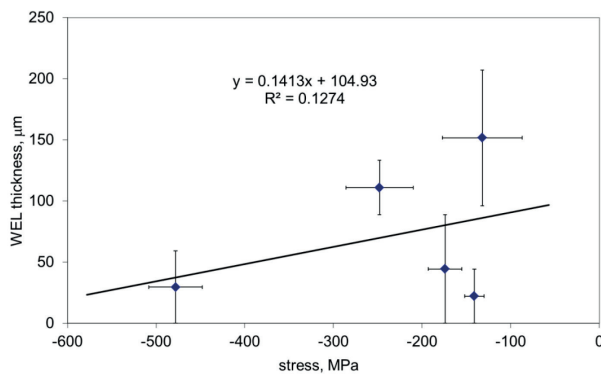

Fig. 5 Residual stresses versus WEL thickness

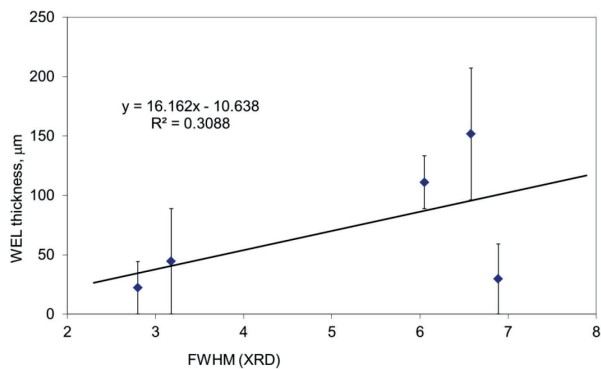

Fig. 6 FWHM versus WEL thickness

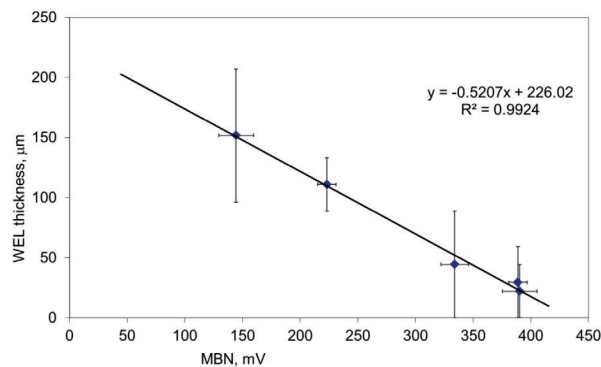

Fig. 7 MBN versus WEL thickness

Table 2 and Fig. 7 show very good sensitivity of MBN versus WEL thickness. Relation between MBN and WEL thickness is linear and increasing WEL thickness can be directly linked with decreasing magnitude of MBN signal. The main reasons can be found as follows:

- much higher sensing depth of MBN technique (compared with XRD technique),
- martensite matrix of the high degree of lattice tetragonality containing carbon in the supersaturated state, high dislocation density and the corresponding high hardness,
- retained austenite in the WEL strongly hinder BW motion,
- oxides (FeO and Fe<sub>2</sub>O<sub>3</sub>) as hard ferromagnetic particles embedded in the martensite matrix also strongly pin BW motion,
- micro cracks such as defects not producing MBN emission.

Figure 7 shows that thickness of WEL can be easily obtained from MBN signal; thus damaged rail layer can be monitored in a non destructive manner.

#### 4. Conclusions

Micro cracking in the hard and brittle WEL arises from the cyclic long term loading and potentially can initiate rail macro cracking. For this reason, rails should be subjected to the re-grinding process in order to remove the damaged layer and refresh the surface state. MBN technique could be potentially employed for the assessment of WEL thickness as a layer removed by grinding. Finally, this is the pilot study which would suggest a possible concept for prevention of unexpected rails deformation (or cracking) due to their thermal dilatation (and the corresponding stresses) initiated by the ambient temperature fluctuations via MBN technique. However, MBN emission initiated by external stresses is combined with MBN from the accumulated damage of the rail surface due to its cyclic severe loading.

#### Acknowledgement

This work was supported by the VEGA project No. 1/0254/15 and project: University Science Park of the University of Zilina (ITMS: 26220220184).

**References**

- [1] PAL, S., DANIEL, J. T., VALENTE, H. G., WILSON, A., ATRENS, A.: Surface Damage on New AS60 Rail Caused by Wheel Slip, *Engineering Failure Analysis*, 22, 2012, 152-165.
- [2] TAKAHASHI, J., KAWAKAMI, K., UEDA, M.: Atom Probe Tomography Analysis of the White Etching Layer in a Rail Track Surface, *Acta Materialia*, 58, 2010, 3602-3612.
- [3] SANTA, J. F., TORO, A., LEWIS, R.: Correlation between Rail Wear Rates and Operating Conditions in a Commercial Railroad, *Tribology International*, 95, 2016, 5-12.
- [4] NEWCOMB, S. B., STOBBS, W. M.: A Transmission Electron Microscopy Study of the White-Etching Layer on a Rail Head, *Materials and Science Engineering Materials and Engineering*, 66, 1984, 195-204.
- [5] WANG, L., PYZALLA, A., STADLBAUER, W., WENER, E. A.: Microstructure Features on Rolling Surfaces of Railways Rails Subjected to Heavy Loading, *Materials and Science Engineering Materials and Engineering*, A 359, 2003, 31-43.
- [6] KARPUSCHEWSKI, B., BLEICHER, O., BEUTNER, M.: Surface Integrity Inspection on Gears Using Barkhausen Noise Analysis. *Processing Engineering*, 19, 2011, 162-171.
- [7] MOORTHY, V., SHAW, B. A., MOUNTFORD, P., HOPKINS, P.: Magnetic Barkhausen Noise Emission Technique for Evaluation of Residual Stress Alteration by Grinding in Case - Carburized En36 Steel, *Acta Materialia*, 53, 19, 2005, 4997-5006.
- [8] GATELIER-ROTHERA, C., CHICOIS, J., FOUGERES, R., FLEISCHMANN, P.: Characterization of Pure Iron and (130 p.p.m.) Carbon-iron Binary Alloy by Barkhausen Noise Measurements: Study of the Influence of Stress and Microstructure. *Acta Metallurgica*, 46, 14, 1998, pp. 4873-4882.
- [9] CIZEK, J., NESLUSAN, M., CILLIKOVA, M., MICIETOVA, A., MELIKHOVA, O.: Modification of Steel Surfaces Induced by Turning: Non-Destructive Characterization Using Barkhausen Noise and Positron Annihilation, *J. of Physics D, Applied Physics*, 47, 2014, 1-17.
- [10] NESLUSAN, M., CIZEK, J., KOLARIK, K., MINARIK, P., CILLIKOVA, M., MELIKHOVA, O.: Monitoring of Grinding Burn via Barkhausen Noise Emission in Case-Hardened Steel in Large-Bearing Production, *J. of Materials Processing Technology*, vol. 240, 2017, 104-117.
- [11] PITONAK, M., CANGAR, M.: *Non-Destructive Testing of Settling Tank*, *Advances and Trends in Engineering Sciences and Technologies*, Proc. of the Intern. Conference on Engineering Sciences and Technologies, ESaT 2015, 353-358.

Lucie Sara Zavodna - Jan Zavodny Pospisil\*

## YOUTUBE AS A NEW MEANS OF MARKETING COMMUNICATION

*This paper discusses a new trend in marketing communication represented by a new generation of YouTubers. The target group, young people aged 12-16, is absorbed in following the YouTubers who set the trends in shopping; not only what one should buy but also when. There is often some kind of cooperation between the YouTubers and some of the well-known companies that provide sample bags with their products for the YouTubers for free. This paper analyzes the Czech YouTube environment, YouTube blogs from channels in English and the results of a questionnaire survey which was conducted on a sample of students who could be described as the Generation Y.*

**Keywords:** Trends, Marketing communication, YouTube, Internet.

### 1. Introduction

After the printing press was invented, it took more than another 400 years until the newspaper spread out massively and the potential of this invention was maximized. Whereas in the past, the newspaper was accessible only to the elites, the 19th century brought the daily press to all social classes. Rotary presses churned out high circulation of newspapers even several times a day.

When the then Czechoslovakia was first connected to the internet on February 13, 1992, the lay public was practically unaware of such network. On February 14, 2005, exactly 13 years and one day later, the YouTube server designated for sharing home-made videos was activated. The internet was a massively used medium in the Czech Republic at that time, referred to as “the gravedigger” of the classic newspaper printed on paper.

More than 10 years later, some refer to the YouTube server as “the gravedigger” of another, today classic, medium, the TV. The thing is that over the 10 years of its existence, the server became a fundamental means of mass communication, which is, unlike the classic media, available to general public and thus creates a completely new platform of media communication.

### 2. YouTube

YouTube is the biggest internet server for sharing videos. It is a place where everyone can upload, share, watch and also comment on originally created videos. A place where ordinary people can, practically without any need of investment, compete with big media

companies and corporations not only in terms of viewer ratings but also in terms of the number of loyal followers.

The aim of this paper is to closely examine the group of Czech users of this server, the YouTubers, who publish their videos on a regular basis for a specific group of followers, usually teenagers aged 12-16. However, older viewers or followers are no exception. A recent survey of TNS Aisa company showed that there is a greater hit rate from YouTube than from any other classic Czech TV channel for viewers aged 15-35 [1]. This makes YouTube a very perspective marketing-communicative channel and YouTubers then often become a new kind of media celebrities.

When compared to the classic TV, YouTube provides a countless number of plus points for the young generation ranging from the possibility to play the video “on demand” or the possibility to use the shortened format of videos to the possibility to make one’s own videos as mentioned above. One can make “friends” or rather a portfolio of faithful followers and can exercise their typical influence of the opinion leader or, as used in the YouTube environment, influencer on them [2].

Even though Czech YouTubers have been uploading their videos on YouTube approximately since 2010 and those from the USA started even earlier, the massive expansion of video blogs or blogs can be perceived in the Czech Republic only in the last two years. Vlogging, following the lead of the USA, became a massive trend in the Czech Republic. However, unlike the well mapped USA market, the Czech environment lacks a relevant and independent analysis. It is necessary to determine the situation on the domestic market and also to consider whether the issue touches also other areas such as the concept of sustainability or others. Such is the aim of this paper.

\* Lucie Sara Zavodna, Jan Zavodny Pospisil

Department of Applied Economics, Philosophical Faculty, Palacky University in Olomouc, Czech Republic  
E-mail: jan.zavodny@upol.cz

### 3. Methods

The Czech part of the research was conducted in a form of an analysis of 15 Czech YouTubers with channels with more than 100,000 followers. All of the channels belong to natural persons. In most of the cases the channel belongs to one YouTuber, only one channel belongs to two persons. Ten videos on various topics and from various dates were randomly chosen from each channel. 20% of the chosen YouTubers were men. The duration of the spots ranged up to 10 minutes. The channels were chosen from a top list published by the Socialblade web platform.

Moreover, a summary questionnaire called Media in the life of students was created and was used for collection of questions of students who belong to the Czech Generation Y - year of birth 1987-1996 [3]. The questionnaire was used for collection of several data, yet one part was focusing directly on watching YouTube. The questionnaire was accessible in Google Docs, from February to June 2016. Altogether, 743 respondents completed the questionnaire, 33% of which were men.

### 4. YouTubers in the Czech Republic

The Czech language version of YouTube was launched October 9, 2008 [4]. Since then, a dynamic increase can be seen not only in daily access to the website and the number of watched videos but also in the number of uploads of users' videos as well as in the number of individuals uploading their videos [5]. The video clip called Patnactny (My fifteenth birthday) of the all-girl band called LuSteLa is said to be one of the first Czech videos that spread virally via YouTube. It was uploaded to YouTube in March 2010 and up to now has almost 1.4 million views [6]. The quality of the content was not the main reason why the video spread virally; even though it was meant to be a true, serious video clip, it became a self-parody to some extent and thus fulfilled one of the criteria for becoming a viral video [7].

First video bloggers started to upload their videos to YouTube the same year. One of the first videos were the specific beauty videos [8] in which young female bloggers usually review cosmetics, clothes or fashion accessories. At that time, young bloggers of the opposite sex most often uploaded videos in which they shot themselves while playing computer games. Such bloggers are usually also called Let's Players [9]. An increase in users' videos on various topics the main aim of which is to amuse the viewers and to some extent also fulfill the same function as blogs in the past can be seen only since 2012 in the Czech Republic.

The format mentioned above with all its characteristics gave birth to a new media genre called blog [10]. It is a multimedia genre the core of which forms a video recording starring the video maker himself or herself. The main speech format used for addressing the audience is monologue [11]. The author of the video creates its content with the monologue and also subsequently edits the video, which is typical

of this genre as well, and thus determines the final form of the vlog. Even though such videos are designed as an improvised monologue, the actual form of the vlog is a result of a thorough choice made through editing the recording. Therefore the vlog as a genre cannot be considered a pure improvisation.

Speaking of other characteristics, the vlog reflects the internet environment and allows almost unlimited spreading of the original information within the hypertext principle [12]. The bloggers make use of this by adding further information below the video, by posting links to social networks but also by leading a dialogue through interaction with other users who comment on the published video.

One of the characteristics of vlog as a genre is the possibility of indirect interaction with the audience. Such interaction is usually realized through the possibility to comment on the video in the space below as mentioned above. The author of the video can communicate with the viewers through textual response to such comments. Vloggers can also respond to comments through other vlogs and the comments can also serve as a subject of another vlog. Social networks are another possible form of interaction with the audience. The most commonly used social network in the Czech Republic, Facebook, is simply not enough for the YouTubers of today. They often use also other social networks such as Ask, Snapchat, Instagram and to a limited extent also Twitter.

The audience is thus connected to the YouTubers through several channels. The sense of togetherness with the YouTuber on the one hand and the participation of the audience on the vlog on the other delude the authors as well as the audience into thinking of a collective community, often referred to as a family [7].

Vlog as a genre also introduces a specific language [10] or rather slang to the media scene, which introduces new anglicisms into Czech. Vloggers pronounce English words with Czech accent such as haul /ho:l/, ask /a:sk/, tag /ta:k/, DIY /di:iwa:i/, stream /stri:m/, unboxing /anboxink/, merchandising /me:rtʃ/ and so on even though there are equivalents for such words in Czech as well, sometimes even several equivalents. All Czech vloggers use such specific anglicisms to some extent. The pronunciation together with the English word order influences their speech, which turns into a new slang form of Czech: Czenglish [12].

Borrowing of words and phrases from original American videos is to some extent symptomatic for Czech YouTubers because, in this case, they copy not only the complete form but often also the content of vlogs itself. Such content is then adapted to the Czech environment, which in some cases causes laughter or even disgust with some members of the audience. Some YouTubers also copy the categories of such genre or rather formats of vlogs. A wide range of vlog formats [13] can be found in the US while basically only six basic formats were adopted in the Czech environment. These are: videos about cosmetics or fashion (beauty), playing computer games (games), insight into YouTuber's life (vlog), shopping (haul, shopping), funny videos including challenges (fun) and also videos from the DIY category (DIY).

Other categories, such as informative videos and instructions, a vast number of home videos and other fun videos can be found among the Czech YouTube videos as well. However, such videos lack the specific characteristics of the genre typical for YouTubers, who are discussed in this article, or rather do not have all the characteristic features of the genre.

## 5. Czech Youtubers as a specific marketing tool

Three years later if not more after the YouTubers in the US and their videos became a tool for profit generation on the part of the video makers themselves as well as on the part of various third parties, the same thing happened in the Czech Republic. YouTubers generate profit in the form of remuneration for placing the advertisement in the video with the growing number of unique views of videos or rather with the number of regular followers. The advertisement can have a textual, graphical or audiovisual form and is placed in the videos by the provider of YouTube, Google company, in accordance with the clients' demands [14]. The author of the video gains 55% of the amount of money the advertiser paid for the advertisement for every thousand views of the advertisement before the author's video [15]. The remaining 45% goes to Google. The actual amount of remuneration for a given number of views depends on such factors as the type of the video, the quality of the content or its presentation by choosing the appropriate view [16]. The author himself or herself or rather the number of regular followers of his or her channel is also a very important factor. In the Czech Republic, the turning point when YouTubering becomes more than just a small extra income is having at least 100,000 followers [15].

The quoted figure cannot be, however, confirmed from a reliable source because Google does not publish the amount of remuneration for placing an advertisement in videos. It might be a company policy but the way the amount of remuneration is calculated is the essential factor limiting the determination of an actual amount of money for a specific YouTuber. The remuneration is determined according to the investments of the advertisers, yet the factors listed above have an essential influence. At least some general knowledge about the profitability or rather rate of return of chosen YouTubers and their channels can be gained through the American project SocialBlades. The authors of this site publish data certified directly by Google [1]. This data show which YouTubers and which YouTube channels and sites are most important in a given country with respect to several criteria such as the number of followers, viewer ratings and SB Score. The SB Score is an indicator based on a further evaluation of the criteria by the Social Blade company and is similar to the credit rating of individual countries. A generally estimated data about the monthly or yearly profit of a channel or a YouTuber is also stated as a part of the SB Score. ViralBrothers, the channel with the most views in the Czech Republic, has B+ rating and an estimated income ranging from 1,7 to 27,6 thousand USD [17].

The money paid to the YouTubers by the commercial companies for the cooperation between the two of them represent another way of generating profit. The principle of such cooperation is based on the placement of brands of promoted products into the content of the video. It can be a classic testimonial [18], a type of advertising appeal when an important personality mentions the qualities of a product or a brand. A personality, in this case, means the author and at the same time the protagonist of the video, the YouTuber.

It is more and more common, though, to place the product directly in the video so it becomes a more or less natural part of the plot. The YouTuber can either directly admit, for instance in the text about the video or verbally, that he or she placed the product in the video for commercial purposes or it can be some kind of a hidden advertisement. For instance, the Czech YouTuber Michaela Nguyen using the nickname Stylewithme promotes the Mattoni brand in one of her videos. In this video, she accepted a challenge from a fan to drink something in one go and in order to fulfill the challenge, she drank a bottle of water of this brand. From the ethical point of view of the advertisement, there is a problem with the video because of the problematic concept of the scene which gives the impression that Nguyen drinks from a bottle randomly found in the house. However, as the author herself admits, she made an agreement with the Mattoni brand which states that she will promote their products [7].

Such example shows that the new phenomenon of commercial communication within the YouTube environment becomes more and more common. The cooperation between the vloggers and the companies or brands is very promising not only because of the financial attractiveness for the YouTubers but also because of the change in attitude of the young generation to the classic media. As some vloggers confirm [7], the companies sometimes exert pressure on the final form of the video which means that they try to persuade the YouTubers to place the product or brand in the video in a way that will minimize the injury to their image.

There are no hard and fast rules applying to the commercial communication of brands these days in the Czech Republic, which means that the final form of the cooperation on the vlog falls within the competence of the vlogger and the advertiser. It is also true that the willingness to let the commercial partner meddle with the content of the video is different with each YouTuber. It is supposable that the relationship between the YouTuber and the commercial subject might be considerably unbalanced and is usually characterized by the difference in the interest of the parties.

The reasons listed above as well as others led to the constitution of specialized agencies that mediate the cooperation between YouTubers and commercial subjects. These agencies also determine the basic definition of the form of the cooperation to some extent and jointly form the related market space for the commercial realization of YouTubers' additional product sale and promotion of their personal presentation including the presentation of the whole market segment of vloggers. At the present time (7/2016), there are 2 specialized agencies in the Czech Republic, Get Boost and TUBRR, that help YouTubers with the implementation of events for fans,

provide technical consultancy and most importantly negotiate the final form and terms of the relationship between YouTubers and the commercial subjects [7]. The TUBRR agency also participates in the measurement of YouTubers' commercial value [19].

Other subjects, besides the agencies mentioned above, that make use of the new environment of YouTube, vloggers and related market segments are arising as well. Even vloggers themselves sometimes make use of the related commercial opportunities: they sell their own merchandise or in cooperation with other commercial subjects co-organize special conferences for YouTubers and their fans or at least host such conferences. There are 3 such meetings in the Czech Republic at the present time - CineTube, 4FANS and YouTubering.

CineTube is a meeting of Czech and Slovak YouTubers with the screening of their 2 - 5 minutes long premiere videos on a big screen in a cinema. This meeting takes place 4 times a year in various cities of the Czech and Slovak Republic. The advance price of a ticket is 99 CZK and gate price is 149 CZK [20].

4FANS is a two-day Czech conference for YouTube fans. It takes place in Prague. Minors under 15 years of age need the consent of next friend for attendance. The advance price of a ticket is 300 CZK or 700 for VIP zone where the odds of meeting a YouTuber are better. A beauty contest Miss Beauty is a part of the 2017 meeting. There is also an afterparty in a club in the evening [21].

YouTubering is a one-day Czech festival that takes place in two cities - Prague and Brno. The price of a ticket is 599 CZK. According to the organizers, this festival arose from the dream of having a festival for the Generation Z. The festival started in 2015. There are several stages and stands in different sections according to the focus of the YouTubers - gaming, fashion, entertainment, and music [22].

## 6. YouTubers outside the Czech Republic

A similar comparative analysis of domestic and foreign YouTube environment is neither within the compass of the scope of this article nor its aim. Yet having an insight into the foreign, primarily North American, scene of YouTubers is paramount for the Czech Republic. As was mentioned above, Czech vloggers to a great extent copy their American colleagues who are their basic inspiration. It is also true that the North American vlogger space is at least three years ahead of the Czech one regarding the realization of first vlogs. It is thus essential to perceive the American vlogger market as an important space that enables prediction of the development of domestic scene including setting new trends.

It might be very interesting to look back into the statistics of the SocialBlade project that makes a list of the most profitable YouTubers or YouTubers with most views. While there are mainly amateurs together with the Czech mutations of foreign formats of videos, such as the Real-life superheroes (RLSH) phenomenon [23], in the top ten in the Czech Republic, the situation in the North America is different.

Five of the top ten most profitable [1] channels in the US are official channels of various artists who release their records in

cooperation with two or three main music publishing companies - Universal Music Group, Sony Music Entertainment and since August 2015 also Warner Music Group [24]. These companies, together with the owner of YouTube, Google, create a specific environment for sharing video clips under the VEVO trademark [25]. The rest of the top ten channels belongs to professionals as well, all of them fall into the category of entertainment [1].

The professionalization of videoblogs is at a high level in the US while this process is only at the beginning in the Czech Republic. For instance, YouTube provides several professional studios for YouTubers with more than 5 thousand followers [26]. Online video artists who have at least 5,000 subscribers can utilize the studio space and professional equipment free of charge. The facilities also host workshops and social events to YouTube creators. Before shooting videos, the creators can sign up for tutorials and learn how to use the equipment, which includes cameras, microphones, green screens and editing stations [27]. Such studios provided by YouTube are being opened all over the world; the one closest to the Czech Republic is the YouTube studio in Berlin.

Channels offering various kinds of entertainment are the most dominant regarding profit and the number of views in both Czech and American YouTube environment. This might seem as a unifying element for both countries, however, it is not. According to the definition of entertainment as a genre, there are several forms of entertainment, in particular noble, harmless and pulp entertainment [28], and each of these has a different effect on the percipient. Several significant differences can be found between the most important YouTube channels in the Czech Republic and in the US according to such stratification of entertainment. According to another analysis, the entertainment in the US is harmless while the channels with the most views in the Czech Republic offer mainly pulp entertainment. Another difference is that among the American YouTubers, vloggers who also talk about serious topics in their vlogs are very popular. For instance, a famous American vlogger JennaMarbles, whose full name is Jenna Nicole Mourey, often focuses on topics that are important or seen as controversial in the society [29 - 30].

That gives a scope for further research that could discover the cause of the difference of the phenomena. One of the assumptions claims that this could be caused by the delayed development of YouTube environment mentioned above because the Czech YouTubers have not reached such a level of professionalism as their colleagues in the US. In general, the North American vlogger segment can be described as very similar to the Czech one because it is inspired by its American opposite.

There is also a conference for YouTubers called Vidcon in the US, similar to the Czech Republic. It is held in Anaheim, California. There are three types of tickets starting from 150 USD. In 2015, over 21,000 fans, creators, and industry leaders got together on several stages. Fans of YouTubers such as DulceCandy, Amanda Steele, Sprinkle of Glitter, Fleur De Force, Kandee Johnson and Bretman Rock can enjoy themselves during panels with their favorite creators. In the gaming stage, there are panels and discussions about how to

create good gaming content, live gameplay with top creators, etc. There are also various workshops and seminars. Seminar series arm attendees with proven strategies, secrets, and techniques to drive more viewers, engagement and revenue across every significant social video channel [31].

### 7. Results of the research

The evaluation of the questionnaire brought very interesting findings. In the eyes of students, YouTube is one of the most important media for the collection of information. YouTube thus equals radio according to the respondents. From all the respondents, 18% does not watch TV at all and 34% only several times a month - Table 1.

Important Sources of Information According to the Respondents Table 1

| Which of the following media do you consider to be the most important source of information? |     |      |
|--|-----|------|
| TV   | 291 | 39 % |
| Radio  | 95  | 13 % |
| Printed Media  | 178 | 24 % |
| Social Networks  | 436 | 58 % |
| YouTube  | 107 | 14 % |
| Internet News Servers  | 616 | 83 % |
| Other  | 9   | 1 %  |

The respondents most frequently marked the credibility by the mark 4 (where 1 was used to mark the most credible source). This shows that students are aware of the low credibility of this medium. The best marks and thus the most credibility were given to Internet news servers and Printed media. In total, 92% of respondents think that the medium of the future, i.e., the most important medium in the years to come, will be the internet. Only 3% of respondents think that way of television. A very interesting finding is that 28% of the respondents do not read printed newspaper at all - Table 2.

The Credibility of Media as Marked by the Respondents Table 2

| Mark the credibility of the following media the same way as in school (1 most credible, 5 least credible) |      |                |
|---|------|----------------|
|   | Mode | Mode frequency |
| TV  | 3    | 247            |
| Radio   | 2    | 278            |
| Printed Media   | 2    | 258            |
| Social Networks   | 4    | 264            |
| YouTube   | 4    | 277            |
| Internet News Servers   | 2    | 310            |

Only one third of respondents of this questionnaire (36%) stated that they do not watch YouTubers at all. The rest said that they watch them out of boredom (14%) or because they are interested in new trends (14%) or in the life of the YouTubers (7%); only 9% of respondents watch YouTubers instead of television. Regarding the frequency of watching YouTube, 45% of respondents said that they watch YouTube videos regularly every day, 5% watch videos every day, 4% every time when the YouTuber they like publishes a new video. Only 1% of the respondents said that they have their own videoblog, 5% write their own blog.

Fragmented perception of information is characteristic for the internet. People usually do not focus on only one activity, which, in this case, means watching a video. Respondents stated, that they often eat (33%), watch other things on the internet (23%), study or read (12%) and shop (4%) while watching videos. Shopping online while watching a YouTuber may thus easily lead to buying items the YouTuber promotes. Only 8% of respondents stated that they watch only the chosen video. The respondents do not differentiate a YouTuber from a Streamer; more than 60% of respondents could not explain these two terms.

From the point of view of marketing, it was very interesting to find that 14% of the respondents have already bought an item because it was recommended by a YouTuber. If we focus only on respondents who watch YouTubers, the number rises to 27%.

### 8. Conclusion

Making YouTube videos has become quite profitable for many artists as there are currently more than 1 million channels earning revenue through YouTube. Thousands of channels are making six figures annually through selling advertising, and partnering with companies by making videos promoting their products. One billion unique users visit YouTube each month and watch 6 billion hours of video [27].

The YouTube environment turned into a completely new market; its domestic growth potential can be predicted according to the situation in North America. From the point of view of YouTube as a medium and the vlog genre as a means of marketing communication, there is a scope for making use of these for now. Vloggers stand a good chance of connecting with groups of people that, according to the surveys mentioned above, diverge from the old media including classic television. Vlogging is thus a perspective means for connecting with such groups.

The value of YouTube or rather vlog is apparent even in groups that are not a part of the target group. The findings of our research showed that the current university students, often referred to as the Generation Y, perceive YouTube as one of the most important media for the collection of information. However, when compared to the uncritical reception of information from YouTube by the Generation Z, the target audience of many vloggers, the representatives of the university students doubt the credibility of this medium. Nevertheless,

this does not mean that they would not buy the products promoted by a vlogger.

The research also confirmed the results of other researches that show a considerable departure of the young generation from the television. YouTube and vloggers thus fill up the free time of students the same way television did in the past. The fact that some TV stations

try to cooperate with the vloggers is rather an example of a vain effort to keep a part of the audience. Trends of the young generation are not set up by the television as was typical for a long time but rather by the vloggers who are only a few years older. The question is who sets up trends for the vloggers, which leaves room for follow-up research.

## References

- [1] SocialBlade: YouTube. Retrieved from: <http://socialblade.com/youtube/top/country/cz>
- [2] PATTERSON, K. et al: *Influencer: The New Science of Leading Change*. McGraw-Hill Education, 2013.
- [3] MCCRINDLE, M. et al: *Generations Defined*. Ethos, 18.1: 8, 2010.
- [4] POLESNY, D.: *YouTube in Czech Language: Starting Today, the Reality* (in Czech). Retrieved from: <http://www.zive.cz/Bleskovky/YouTube-cesky-od-dnesniho-dne-realita/sc-4-a-143974/default.aspx>
- [5] BILKOVA, L.: *Czech YouTube: Television Channel Number one for Youths. And not only for them* (in Czech). Retrieved from: <http://googlepresscz.blogspot.cz/2014/09/cesky-youtube-televizni-kanal-cislo.html>
- [6] GREGOR, J.: *Who Appreciate it?* (in Czech). Retrieved from: <http://www.respekt.cz/tydenik/2010/6/kdopak-to-oceni>
- [7] JANAUEROVA, B.: Entertainment without End: The Children's Room had Long since Penetrated YouTuber, now beginning to Conquer and Businesses. Or is it vice versa? (in Czech), *Respekt*. Praha : Economia, 2015, 26(48), 40-43. ISSN 0862-6545.
- [8] NAM, S.: "Let's Play": Guck mal, wer da spielt: Die neue Youtube-Masche - Netzwirtschaft - FAZ". *Frankfurter Allgemeine Zeitung* (in German), 2013.
- [9] FROBENIUS, M.: Beginning a Monologue: The Opening Sequence of Video Blogs. *J. of Pragmatics*, 2011, 43.3: 814-827.
- [10] BETANCOURT, R.: Genre as Medium on YouTube: The Work of Grace Helbig. *The J. of Popular Culture*, 2016, 49.1: 196-223.
- [11] OBLAK, T.: *The Lack of Interactivity and Hypertextuality in Online Media*. Gazette, 2005, 67.1: 87-106.
- [12] SPARKLING, D.: *English or Czenglish?: How to avoid Czechism in English* (in Czech), 2nd ed., Praha: Statni pedagogicke nakladatelstvi, 1991, 274 p. ISBN 80-04-25969-3.
- [13] LAVAVESHKUL, L.: How to Achieve 15 minutes (or more) of Fame through YouTube. *J. of Intern. Commercial Law and Technology*, 2012, 7: 370.
- [14] Google: Help for AdWords. *Showing ads in Videos and on Websites with Videos*. Retrieved from: [https://support.google.com/adwords/answer/2404253?hl=cs&ref\\_topic=3119140](https://support.google.com/adwords/answer/2404253?hl=cs&ref_topic=3119140)
- [15] BARTONICKOVA, T.: *YouTube Blogs about Beauty as Lucrative Business* (in Czech), *Marketing.cz*. ISSN 1805-4991. Retrieved from: <http://www.marketing.cz/youtube-blogy-o-krase-jako-lukrativni-byznys>.
- [16] Google: Help for YouTube. *Guidance on Advertiser-friendly Content*. Retrieved from: <https://support.google.com/youtube/answer/6162278>
- [17] *SocialBlade: ViralBrothers*. Retrieved from: <http://socialblade.com/youtube/user/viralbrothers>
- [18] MARTIN, B. A. S., WENTZEL, D., TOMCZAK, T.: Effects of Susceptibility to Normative Influence and Type of Testimonial on Attitudes toward Print Advertising. *J. of Advertising*, 2008, 37.1: 29-43.
- [19] *TUBRR agency*. Retrieved from: <http://start.tubrr.net/reklamni-kampane-s-youtubery/>
- [20] *Cinetube conference* (in Czech). Retrieved from: [cinetube.yt](http://cinetube.yt)
- [21] *4fans conference* (in Czech). Retrieved from: [www.4fans.cz](http://www.4fans.cz)
- [22] *Youtubering* (in Czech). Retrieved from: [www.youtubering.cz](http://www.youtubering.cz)
- [23] HBO Documentaries. *Superheroes: Interview with Michael Barnett*. Superheroes. 2011. Retrieved from <http://www.hbo.com/documentaries/superheroes/interview/michael-barnett.html>
- [24] FLANAGAN, A.: *VEVO, Revivified, Looking to Strike a Deal with Warner Music Group*. Billboard. 2015. Retrieved June 26, 2016.
- [25] HANDL, J.: *VEVO Music Video Server Launched* (in Czech), *Lupa.cz*. 2009. Retrieved from: <http://www.lupa.cz/clanky/hudebni-videoserver-vevo-odstartoval/>
- [26] *Youtube space*. Retrieved from: <https://www.youtube.com/yt/space/>
- [27] New York Daily News: *YouTube Open Professional Studios*. Retrieved from: <http://www.nydailynews.com/new-york/youtube-open-professional-studio-nyc-creators-article-1.1974332>
- [28] BAROSEK, J., DANKOVA, H.: *J. and School: A Guide for Teachers of Media Education* (in Czech), 2008, Frydek-Mistek : Vaclav Danek.

- [29] ONDREJKOVA, D.: *Is the Blonde Funny or Stupid?: American Blogger Breaking Myths about Blondes* (in Czech). Reflex. 2012, 5. 11. 2012, ISSN 1213-8991. Retrieved from: <http://www.reflex.cz/clanek/lajk/48380/je-ta-blondynka-vtipna-nebo-blba-americka-bloggerka-bori-myty-o-plavovlaskach.html>
- [30] WOTANIS, L., MCMILLAN, L.: *Performing Gender on YouTube: How Jenna Marbles Negotiates a Hostile online Environment*. Feminist Media Studies, 2014, 14.6: 912-928.
- [31] *About VidCon*. Retrieved from [www.vidcon.com](http://www.vidcon.com).

Zoran Cekerevac – Zdenek Dvorak – Ludmila Prigoda – Petar Cekerevac\*

## TECHNO-ECONOMIC ASPECT OF THE MAN-IN-THE-MIDDLE ATTACKS

*This paper analyzes some aspects of the man-in-the-middle (MITM) attacks. After a short introduction, which outlines the essence of this attack, there are presented used scientific methods and hypotheses. The next chapter presents technology of MITM attacks and benefits that a successful attack provides the attacker with. Some of the most significant examples of such attacks, which have a larger scale and significant impact on the broader Internet community, are presented. This part of the article ends with an analysis of possible protection against MITM attacks. Later, on the basis of available data, the analysis of MITM attack from an economic point of view is given. In Conclusion, the summary of the whole analysis is performed.*

**Keywords:** Man-in-the-middle, IT, Internet, eavesdropping, ARP poisoning, DNS spoofing, SSL hijacking, Internet of things.

### 1. Introduction

Every IT expert has heard of the Man-in-the-Middle Attacks (MITM), but this type of attacks is very rarely described in details and well classified. Also, there are rarely shown the benefits the attacker hopes to attain. The aim of this paper is to present an analysis of technology of MITM attacks, their relationship with other types of attacks, and some economic factors in this regard.

In successful MITM attacks an attacker can have the ability to receive data and retransmit it without changing or after changing it, so that results can be the eavesdropping or manipulation.

Every IP implementation must include Internet Control Message Protocol (ICMP). To provide services in the safe way most Internet applications use encrypted connections provided by Secure Sockets Layer and Transport Layer Security protocols on the application layer. Although SSL/TLS can create a two-way trust relationship, because of the complexity in administration, SSL/TLS is mostly used with the one-way trust relationship, which means that only one participant can validate the connection. This method of SSL/TLS application represents a weakness that can be exploited by an attacker.

There are several types of MITM attacks:

- ARP cache poisoning,
- DNS spoofing,
- Session hijacking including side-jacking, evil twin, sniffing, ...
- SSL Hijacking.

Articles about MITM attacks can be found in many sources as, for example: [1 - 6], etc.

In the past, MITM attacks mainly affected laptops, but, now, mass population of cell phone users can be under attack. It is hard to expect that such different crowd can protect itself. Except for standard attacks on IP and data, MITM attacks can target *rel="nofollow"* in the mobile devices, and it can be particularly worrying. A successful attack can allow a hacker to identify a person's location, intercept messages or even eavesdrop on conversations [7].

### 2. Used scientific methods and hypotheses

Methodological basis of this research includes the principles of the systemic-functional approach to the analysis of phenomena. In justification of theoretical propositions and arguments, following scientific methods were widely used: hypotheticodeductive method, axiomatic method, analytical-deductive method, and comparative method, scientific abstraction, induction and deduction, synthesis,

\* <sup>1</sup>Zoran Cekerevac, <sup>2</sup>Zdenek Dvorak, <sup>3</sup>Ludmila Prigoda, <sup>4</sup>Petar Cekerevac

<sup>1</sup>Faculty of Business and Law, "Union - Nikola Tesla" University in Belgrade, Serbia

<sup>2</sup>Faculty of Security Engineering, University of Zilina, Slovakia

<sup>3</sup>Faculty of Economics and Service, Maykop State Technological University, Maykop, Russia

<sup>4</sup>Hilltop Strategic Services, Belgrade, Serbia

E-mail: zoran@cekerevac.eu

comparative analysis, as well as analysis of time series, graphical interpretation etc.

Using basic features, their resolving power, and analytical base of each of the above methods used in accordance with their epistemological potential landmark in the process of solving theoretical and empirical tasks, allowed in the context of a single algorithm to achieve the goal of the article and to provide high representativeness of the results and conclusions.

The null hypothesis was set as:

$H_0$  - "MITM attacks are extremely rare and make no damages to any user."

The alternative hypothesis was set as:

$H_1$  - "MITM attacks are not extremely rare and can cause losses to victims".

### 3. MITM technology

The man-in-the-middle attack, by using different techniques, intends to intercept a communication between two nodes, client, and server. The attacker splits the original TCP connection into 2 new connections. Once the TCP connection is intercepted, the attacker gets the opportunity to read, insert and modify the data in the intercepted communication [5].

An example of the MITM attack is shown in Fig. 1. The attacker interrupted the connection of his victims and usurped the role of a proxy.

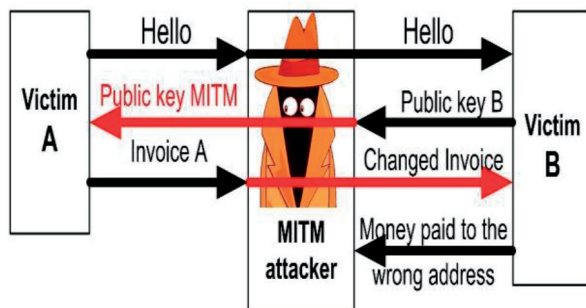

Fig. 1 An example of the MITM attack  
Source: Authors based on the [3]

How to conduct a simple man-in-the-middle attack is described in details in the eponymous article [8], therefore, it will not be presented here. After catching the username and the password, the attacker has all that he needs to attack. The attacker can have additional benefits if the victim uses the same username and password for all services and systems.

The main drawback of millions of HTTPS, SSH and VPN servers is that prime numbers generated by Diffie-Hellman key exchange are all the same. With advancements in technology new algorithms appeared, as Field Sieve, which can very efficiently break Diffie-Hellman connections. Nowadays, when

two wireless devices share their secret keys by creating a secure channel between them, this is nothing but the Diffie-Hellman exchange [9]. More about scanning for victims, auto detection of local interfaces and default gateways, as well as about the setting up the MITM attacks for the victims, routers, IP forwarding, and restoring the victim after attack was done, can be found in numerous sources, e.g. [10 or 9].

### 4. Are MITM attacks rare?

Man-in-the-middle attacks existed long before the appearance of computers. One good example might be a malicious postman who opens people's letters and takes or changes their contents before handing over the letter to its recipient. But now man-in-the-middle attacks are essentially eavesdropping and/or manipulating attacks.

According to McAfee research [11] the most frequent are denialofservice and browser attacks. Together, they make 64% of all attacks. They together with SSL attacks constitute the MITM attack. Many protocols that are used every day are vulnerable to various attacks in one way or another, simply because it's quite hard to devise a protocol that's completely secure against MITM. Most solutions are only "best effort", and not "completely and absolutely secure" solutions.

Are the "man in the middle" attacks actually rare in the real world? Data say that MITM is quite credible for concern. The Dutch High Tech Crime Unit's data say that according to their 32 data breach, statistics 15 involved MITM actions [12, p. 69].

In June 2015, 49 persons were busted in Europe for Man-in-the-Middle bank attacks [13]. They were arrested on suspicion of using MITM attacks to sniff out and intercept payment requests from email. This fraud was at the level of €6 million, and was conducted in a "very short time". Targets were medium and large European companies. A similar attack was when crooks were targeting customers of Absa, one of the Big Four banks in South Africa, in 2013. In that case, fraudsters made a fake site looks very professional buyers who will reach it by clicking on a link in a phishing e-mail (a good reason to avoid doing it; instead, type in the URL yourself), asked users to enter their passwords and the Random Verification Number code that Absa sends to mobile phones as a one-time password [13]. The whole scam was carried out with a lot of errors, but it was nevertheless in many cases successful. Although in e-banking some of the controls brought in by banks (two-factor authentication etc.) were applied to combat the attacks on customers, this case shows that they are not always sufficient.

There are, also, many other ways to attack e-banking users as the use of malware to place a Trojan on the client PC, but MITM is still relatively easy in most cases. The main reasons for MITM attacks are:

- low risks - physical and to be caught,

- some effort in coding the exploit can lead to real world monetary gain, and
- the code can then be reused or sold to other criminals.

It seems that the larger problem is how to wash the stolen money and not to be detected than to reveal the fraud.

However, the theft of money is not always the goal of the scam. Some say that “...employer does an MITM attack on us. They use it in order to monitor our email and prevent us from sending attachments” [14]. Michael Hex [15] claims that MITM attacks within companies happen daily and more than once. Others think that MITM attacks are “common enough to be an official government policy” [16].

One of the most interesting incidents happened in the year 2008. FARC (Revolutionary Armed Forces of Colombia) was attacked by series of DoS and MITM attacks in order to free up 15 hostages. These attacks freed them without a single ammunition being involved [17].

One of the first, well-known MITM attacks was the Mitnick attack. To take over a session Mitnick exploited the basic design of the TCP/IP protocol. The attack was performed through:

- identifying weaknesses of the network and collecting the necessary information,
- silencing the actual network server and replacing it with own computer, and
- hijacking.

Mitnick’s attack to Shimomura’s computer is in details described in [18]. An identical attack is nowadays impossible because we don’t use *rsh*; but we use SSH [19].

Nowadays many other possible scenarios can exist:

- command injection; useful where one-time authentication is used,
- malicious code injection; malicious code insertion into an email or web pages,
- key exchanging; public key exchanged by server and client modification,
- parameters and banners substitution; Parameters exchanged by server and client can be substituted in the beginning of a connection. For example, the attacker can force the client to initialize an SSH1 connection instead of the SSH2,
- IPSEC failure; Block the key material exchanged on the port 500 UDP. If the client is configured in rollback mode, there is a good chance that the user will not notice that the connection is in clear text,
- PPTP attacks; The Point-to-Point Tunneling Protocol as the method for implementing VPNs has many known security issues,
- Transparent proxy; The attacker adds his own URL in the front when the victim loads the URL of a defaced web page.

More details about mentioned scenarios can be found in [20 - 21].

One attack of enormous size using MITM technology was performed by the NSA in 2013. Tor was attacked to be compromised. Previous attacks failed to directly break Tor, but this attack was more successful by using vulnerabilities in Firefox to target certain Tor users. The attack was possible because of the major telcos letting the NSA put servers directly off the backbone. More detailed explanation of this attack can be found in [22].

One of the recent man-in-the-middle attacks was in July 2015 hacking a Jeep Cherokee, which caused a major recall by Chrysler Corporation. Without important security safeguards being put in place and rigorously tested, hackers can eventually control the vehicles’ basic functions, such as brakes, steering, and acceleration which could be highly dangerous [23]. A modern car may be connected to multiple networks including cellular, V2V/V2I/V2X, Bluetooth, Wi-Fi and Wired Automotive Ethernet, and this appears as an added risk. Many people still don’t realize, but beside the TVs, the IoT will soon involve many devices as washing machines, refrigerators, etc. Each home device will have an IP address and therefore, will be vulnerable to attacks.

In March 26, 2016, GitHub experienced the largest DDoS (distributed denial of service) attack in its history. The attack involved a wide combination of attack vectors. These included every vector they had seen in previous attacks as well as some sophisticated new techniques that used the web browsers of unsuspecting, uninvolved people to flood github.com with high levels of traffic [24]. Netresec made a deeper analysis of this attack and concluded that China was using their active and passive network infrastructures in order to perform a packet injection attack, known as a man-on-the-side attack against GitHub [25]. The man-on-the-side attack is similar to MITM attack, with similar technology, but with less controlling of a network node.

In October 21, 2016, a series of DDoS attacks caused rough disruption of legitimate internet activity in the US. The attacks targeted the Domain Name System and were perpetrated by directing huge amounts of bogus traffic at targeted servers belonging to Dyn which is a major provider of DNS services to other companies. A lot of activities such as online shopping, social media interaction, etc., were not possible to use for some periods of time. The length of disruptions varied, but in some cases, it took several hours. Detailed information about October 21 attack can be found in [26].

And finally, the answer to: “Are MITM attacks rare?” is No! Some, more stringent, analysts say that any instance of an SSL root getting a bad cert can consider it as a sign of an attack. One should always bear in mind that MITM can be part of a denial-of-service attack [27].

## 5. How to confront MITM attacks?

Michael Gregg [28] named six ways how one can become a victim of MITM attack:

- Wi-Fi Eavesdropping,
- Man-in-the-browser,
- Man-in-the-mobile,
- Man-in-the app,
- Man-in-the-cloud, and
- Man-in-the-IoT.

It is a great variety of possible attacks. Complete elimination of MITM attack is a very difficult task, but the careful user can significantly reduce the risk.

Several security vendors have solutions to scan encrypted traffic (for example, Palo Alto Networks, Kaspersky Internet Security 2015, etc.) and the companies can activate this feature. To do this, the firewall/proxy device is simply granted a certificate from internal Certificate Authority (CA) which is already trusted by all clients. When an application asks for a secure connection, the firewall/proxy device generates a new certificate for the target server on the fly and sent it to the client. Since the client trusts the internal CA, it also trusts the device certificate and will happily start a “secure” connection.

MITM attacks are the preferred choice of attack for surveillance groups who want to sniff on the data on a connection [9]. From defender’s point of view, ARP cache poisoning happens in the background with very few chances to be controlled by the user. Although difficult, some of the countermeasures can be adopted to provide a shield. There is no catch-all solution, but proactive and reactive measures can be taken.

New patched and updated operating systems must be used on a network. Also, security of network should be the primary concern while designing it [9]. If the network configuration is not changing frequently, it is quite feasible to make a listing of static ARP entries and deploy them to clients via an automated script. This can ensure that devices rely on their local ARP cache rather than relying on ARP requests and replies [6]. This way the process is little less dynamic.

DNS spoofing is mostly passive by its nature so it is difficult to defend. Users never know that their DNS is being spoofed until it has happened. In very targeted attacks it is possible that the user may never know that he has been tricked into entering his credentials into a false site until he receives a bill from his bank. But, there are still a few things that can be done to defend against these types of attacks [29]:

- internal machines securing,
- not to rely on DNS for secure systems,
- use of IDS, and
- use of DNSSEC.

Unless the attacker makes some of the obvious action when he hijacks a session, one may never know that an

attacker was there. A few things can be done to better defend against session hijacking [30]:

- to do online banking from home,
- to be cognizant and keep an eye out for things that seem unusual, and
- to secure own internal machines; such attacks are mostly executed from inside the network.

SSL hijacking is virtually undetectable from the server side because for the server the communication with a client is quite normal. He can’t see that he communicates with a proxy. Some things can be done from the client’s side [31]:

- to ensure secure connections using HTTPS,
- to do online banking from home, and
- to secure own internal machines.

## 6. The Economic Aspect

It is rather rare to find real world data on MITM attacks. One of the reasons is that MITM attacks are by their nature usually targeted at individuals. On the other hand, “a lot of the attacks you hear about are just the tip of the iceberg. Banks often won’t even tell an affected customer that they have been a victim of these man-in-the-middle attacks” [32]. Franklin also said: “ ‘man-in-the-browser’ attacks are emerging to compete in popularity with middleman threat”, and that (in Europe, Middle East and Africa, in 2007) “3.5 million adults remembered revealing sensitive personal or financial information to a phisher, while 2.3 million said that they had lost money because of phishing. The average loss is US\$1,250 per victim”.

The situation with defining costs caused by MITM attacks is more complicated when we know that, as mentioned earlier, MITM attacks are closely connected with the major attacks, including DDoS.

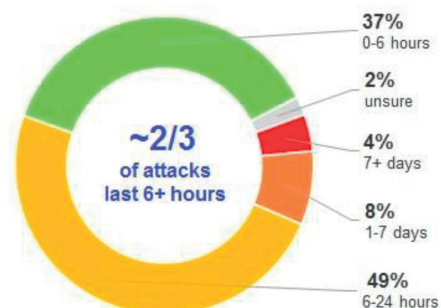

Fig. 2 The average attack length  
Source: Authors based on [34]

Analyzing a DDoS attack in October 21, 2016, LaFrance [33] claimed that in the year 2014 “For more than one-third of companies, a single hour of a DDoS attack can cost up to

\$20,000". Matthews [34], upon an examination, concluded that "the data reveals there are no predictable patterns as to how long an assault will last". Some statistics is given in Fig. 2. It is easy to multiply cost for an hour by the number of hours and the number of attacks. For some companies, it can reach millions. "The airline Virgin Blue lost \$20 million in a period of IT outages that spanned 11 days in 2010" [33].

Per Ponemon global study and research of 2016 cost of data breach [35] that covered 383 companies, the average total cost was increased from \$3.79 (in 2015) to \$4 million (in 2016). The average cost of stolen or lost record containing sensitive information was increased from \$154 (in 2015) to \$158 (in 2016). Comparing to 2013 total cost of a data breach is increased or 29%, or 15% per capita. It is interesting that risks from a data breach are not evenly distributed. Organizations in Brazil and South Africa are much more exposed to material data breaches then organizations in Germany and Australia.

The Ponemon analysis showed that a cost per compromised record, or per capita, in average is on the level of \$158. The highest values are in healthcare organizations with \$335, then in education (\$246), transportation (\$129), research (\$112), and public sector (\$80). The most data breaches were caused by hackers and criminal insiders. The analysis showed that 48% were caused by criminal attacks. The average cost of attacks resolving was \$170, while costs of system glitches and human errors were \$138 and \$133 respectively. The most expensive resolving of attacks was in the US (\$236), and the cheapest was in India (\$76 per record).



Fig. 3 Impact of 16 factors on the per capita cost of data breach [35]



Fig. 4 Lost business costs for 383 companies in US\$ million  
Source: [35]

Fig. 3 shows the actors that influence the cost of incident resolving. The third-party involvement caused an increase of \$14.

Carried out attacks that prevent companies from doing business on the Internet mostly affect those companies that are more oriented to the Internet and especially companies that operate in the most developed countries. The costs of business losses were particularly high in the case of US companies, as shown in Fig. 4.

These losses include reputation losses, goodwill diminishing, increasing of customer acquisition activities, and the abnormal turnover of customers.

### 7. Conclusions

Theft and eavesdropping have existed since the beginning of time. Today they are largely migrating to the Internet. The struggle is constant and the attackers usually take advantage of both in terms of knowledge and technology at their disposal. MITM attacks, despite some limitations, remain effective technology for carrying out attacks and acquiring illegal benefits. They are performed in different versions, but with the same basic idea. An MITM is often combined with other attacks or built into them.

MITM attacks are usually performed in order to acquire some benefit, financial or non-financial. In cases where private individuals were attacked, the attacks often remain undiscovered and statistically unrecorded. In the cases of attacks on economic operators the attacks often remain hidden to public to preserve the company's image, so in these cases it is also difficult to accurately assess the consequences. Only in cases of large-scale attacks, when they hit a lot of Internet users the extent of the damage caused comes to light.

Despite difficulties in collecting relevant data, this analysis on some examples showed the extent of the damage that can be caused by MITM attacks. Also, the analysis showed that the most vulnerable are mobile devices and Wi-Fi data transmission and that the biggest threat to users is when they are connected to the Internet via a public Wi-Fi connection.

It is not possible to provide a protection that would be effective in all circumstances and in all situations, but for all users, a good idea is not to use public Wi-Fi in situations when doing anything sensitive and/or confidential.

Analysis showed the great potential of IoT, but also the risks that may occur from insufficient protection.

Finally, the research showed that the null hypothesis  $H_0$  is rejected. The research showed that the MITM threat is real, and that can bring significant losses to victims. That way the alternative hypothesis  $H_1$  is proven.

## References

- [1] PRIGODA, L., et al.: *One Look at the Modern Information Security*. Sustainable Development of Mountain Territories, vol. 4, No. 22, Apr 19, 2015.
- [2] CEKEREVAC, Z., DVORAK, Z., CEKEREVAC, P.: *Internet Safety of SMEs and E-mail Protection in the Light of Recent Revelations about Espionage of Internet Communication System*. Chernivtsi : Bukovina University, Zbirnyk naukovykh prats' Bukovyns'koho universytetu. Ekonomichni nauky, vol. 10, 2014, 2219-5378.
- [3] DuPAUL, N.: Man in the Middle (MITM) Attack. *Veracode*. [Online] [Cited: Nov 28, 2016.] <http://www.veracode.com/security/man-middle-attack>.
- [4] GANGAN, S.: *A Review of Man-in-the-Middle Attacks*. *arXiv.org*. [Na mrezi] 2015. <https://arxiv.org/ftp/arxiv/papers/1504/1504.02115.pdf>.
- [5] OWASP.: *Man-in-the-middle Attack*. *OWASP*. [Online] Aug 31, 2015. [https://www.owasp.org/index.php/Man-in-the-middle\\_attack](https://www.owasp.org/index.php/Man-in-the-middle_attack).
- [6] SANDERS, C.: Understanding Man-in-the-Middle Attacks - ARP Cache Poisoning, Part 1, *Windowsecurity*. [Online] Mar 17, 2010. [http://www.windowsecurity.com/articles-tutorials/authentication\\_and\\_encryption/Understanding-Man-in-the-Middle-Attacks-ARP-Part1.html](http://www.windowsecurity.com/articles-tutorials/authentication_and_encryption/Understanding-Man-in-the-Middle-Attacks-ARP-Part1.html).
- [7] COVINGTON, M.: Free Wi-Fi and the dangers of mobile Man-in-the-Middle attacks, *Betanews*. [Online] Oct 8, 2016. <http://betanews.com/2016/10/08/free-wi-fi-mobile-man-in-the-middle-attacks/>.
- [8] —. How to Conduct a Simple Man-in-the-middle Attack, *Wonderhowto*. [Online] 2014. <http://null-byte.wonderhowto.com/how-to/hack-like-pro-conduct-simple-man-middle-attack-0147291/>.
- [9] KAPIL, J., MANOJ, J. and BORADE, J.: *A Survey on Man in the Middle Attack*. *IJSTE*, vol. 2, No. 9, 2016, pp. 277-280.
- [10] EDWARDS, R.: Simple Man-in-the-Middle Script: For Script Kiddies. *Wonderhowto*. [Online] Aug 119, 2016. <http://null-byte.wonderhowto.com/news/simple-man-middle-script-for-script-kiddies-0168192/>.
- [11] McAfee.: *McAfee Labs Threats Report, September 2016*. CA: Santa Clara: Intel Security, 2016.
- [12] BAKER, W., et al.: *2011 Data Breach Investigations Report, Part. 1*, Verizon, 2011. p. 74.
- [13] VAAS, L.: 49 Busted in Europe for Man-in-the-Middle Bank Attacks. *Naked Security*. [Online] Jun 11, 2015. <https://nakedsecurity.sophos.com/2015/06/11/49-busted-in-europe-for-man-in-the-middle-bank-attacks/>.
- [14] USER606723.: Are “man in the middle” attacks extremely rare? *Information Security*. [Online] Feb 22, 2012. <http://security.stackexchange.com/questions/12041/are-man-in-the-middle-attacks-extremely-rare>.
- [15] HEX, M.: Are “Man in the Middle” Attacks Extremely Rare? *Information Security*. [Online] Feb 22, 2012. <http://security.stackexchange.com/questions/12041/are-man-in-the-middle-attacks-extremely-rare>.
- [16] JUPP0R.: Are “Man in the Middle” Attacks Extremely Rare? *Information Security*. [Online] Feb 22, 2012. <http://security.stackexchange.com/questions/12041/are-man-in-the-middle-attacks-extremely-rare>.
- [17] VIECCO, C, CAMP, J.: *A Life or Death InfoSec Subversion*. 5, 2008, Security & Privacy, Vol. 6, pp. 74-76.
- [18] ERIKSSON, M.: *An Example of a Man-In-The-Middle Attack Against Server Authenticated SSL-sessions*. Stockholm: Simovits Consulting, 2016.
- [19] SUNDARAM, R.: The Kevin Mitnick Attack. *Northeastern University*. [Online] Feb 16, 2011. <http://www.ccs.neu.edu/course/cs6740/Lectures/Lecture-7.pdf>.
- [20] ORNAGHI, A., VALLERI, M.: *Man in the Middle Attacks*. Amsterdam: BlackHat, 2003. Blackhat Conference. p. 61.
- [21] ORBITCO.: What is Man in the Middle Attacks ? Explained with Examples, *Orbit-computer-solutions*. [Online] Nov 9, 2015. <http://www.orbit-computer-solutions.com/network-attack-man-in-the-middle-attacks/>.
- [22] SCHNEIER, B.: Attacking Tor: How the NSA Targets users' online Anonymity . *The Guardian*. [Online] Oct 4, 2013. <https://www.theguardian.com/world/2013/oct/04/tor-attacks-nsa-users-online-anonymity>.
- [23] SIMKO, C.: Man-in-the-Middle Attacks in the IoT. *GlobalSign*. [Online] Feb 26, 2016. <https://www.globalsign.com/en/blog/man-in-the-middle-attacks-iot/>.
- [24] NEWLAND, J.: Large Scale DDoS Attack on github.com. *github*. [Online] Mar 27, 2015. <https://github.com/blog/1981-large-scale-ddos-attack-on-github-com>.
- [25] —. China's Man-on-the-Side Attack on GitHub. *Netresec*. [Online] Mar 31, 2015. <http://www.netresec.com/?page=Blog&month=2015-03&post=China%27s-Man-on-the-Side-Attack-on-GitHub>.
- [26] COB, S.: 10 things to know about the October 21 IoT DDoS attacks, *Welivesecurity*. [Online] Oct 24, 2016. <http://www.welivesecurity.com/2016/10/24/10-things-know-october-21-iot-ddos-attacks/>.

- [27] CISCO: Threats in Borderless Networks. *LearnCisco*. [Online] n.d. <http://www.learnisco.net/courses/iins/common-security-threats/threats-in-borderless-networks.html>.
- [28] GREGG, M.: Six Ways You Could Become a Victim of Man-in-the-middle (MiTM) Attacks this Holiday Season. *The Huffington Post*. [Online] 12 11, 2015. [http://www.huffingtonpost.com/michael-gregg/six-ways-you-could-become\\_b\\_8545674.html](http://www.huffingtonpost.com/michael-gregg/six-ways-you-could-become_b_8545674.html).
- [29] SANDERS, C.: Understanding Man-In-The-Middle Attacks, Part 2: DNS Spoofing, *Windowsecurity*. [Online] Apr 7, 2010A. [http://www.windowsecurity.com/articles-tutorials/authentication\\_and\\_encryption/Understanding-Man-in-the-Middle-Attacks-ARP-Part2.html](http://www.windowsecurity.com/articles-tutorials/authentication_and_encryption/Understanding-Man-in-the-Middle-Attacks-ARP-Part2.html).
- [30] —. Understanding Man-In-The-Middle Attacks, Part 3: Session Hijacking, *Windowsecurity*. [Online] May 05, 2010B. [http://www.windowsecurity.com/articles-tutorials/authentication\\_and\\_encryption/Understanding-Man-in-the-Middle-Attacks-ARP-Part3.html](http://www.windowsecurity.com/articles-tutorials/authentication_and_encryption/Understanding-Man-in-the-Middle-Attacks-ARP-Part3.html).
- [31] —. Understanding Man-In-The-Middle Attacks, Part 4: SSL Hijacking. *WindowSecurity*. [Online] Jun 9, 2010C. [http://www.windowsecurity.com/articles-tutorials/authentication\\_and\\_encryption/Understanding-Man-in-the-Middle-Attacks-ARP-Part4.html](http://www.windowsecurity.com/articles-tutorials/authentication_and_encryption/Understanding-Man-in-the-Middle-Attacks-ARP-Part4.html).
- [32] FRANKLIN, D.: Threatwatch: How much to MITM, how Quickly, how much Lost. *Financial Cryptography*. [Online] July 23, 2007. <http://financialcryptography.com/mt/archives/000941.html>.
- [33] LAFRANCE, A.: How Much Will Today's Internet Outage Cost? *The Atlantic*. [Online] Oct 21, 2016. <http://www.theatlantic.com/technology/archive/2016/10/a-lot/505025/>.
- [34] MATTHEWS, T.: Incapsula Survey: What DDoS Attacks Really Cost Business, *Incapsula*. [Online] 2014. <https://lp.incapsula.com/rs/incapsulainc/images/eBook%20-%20DDoS%20Impact%20Survey.pdf>.
- [35] PONEMON.: *IBM - 2016 Cost of Data Breach Study: Global Analysis*, US-MI: Traverse City : Ponemon Institute, 2016. p. 32.

## COMMUNICATIONS – Scientific Letters of the University of Zilina Writer's Guidelines

1. Submitted papers must be unpublished and must not be currently under review for any other publication.
2. Submitted manuscripts should not exceed 8 pages including figures and graphs (in Microsoft WORD – format A4, Times Roman size 12, page margins 2.5 cm).
3. Manuscripts written in good English must include abstract and keywords also written in English. The abstract should not exceed 10 lines.
4. Submission should be sent by e-mail – as an attachment – to the following address: komunikacie@uniza.sk (or on CD to the following address: Zilinska univerzita, OVAV – Komunikacie, Univerzitna 1, SK – 010 26 Zilina, Slovakia).
5. Uncommon abbreviations must be defined the first time they are used in the text.
6. Figures, graphs and diagrams, if not processed in Microsoft WORD, must be sent in electronic form (as JPG, GIF, TIF, TTF or BMP files) or drawn in high contrast on white paper. Photographs for publication must be either contrastive or on a slide.
7. The numbered reference citation within text should be enclosed in square brackets - in numerical order. The reference list should appear at the end of the article (in compliance with ISO 690).
8. The numbered figures and tables must be also included in text.
9. The author's exact mailing address, full names, E-mail address, telephone or fax number, the name and address of the organization and workplace (also written in English) must be enclosed.
10. The editorial board will assess the submitted paper in its following session. If the manuscript is accepted for publication, it will be sent to peer review and language correction. After reviewing and incorporating the editor's comments, the final draft (before printing) will be sent to authors for final review and minor adjustments
11. Submission deadlines are: September 30, December 31, March 31 and June 30.

## COMMUNICATIONS

SCIENTIFIC LETTERS OF THE UNIVERSITY OF ZILINA  
VOLUME 19

### Editor-in-chief:

Prof. Ing. Otakar Bokuvka, PhD.

### Editorial board:

Prof. Ing. Jan Bujnak, CSc. – SK  
 Prof. Ing. Otakar Bokuvka, PhD. – SK  
 Prof. RNDr. Peter Bury, CSc. – SK  
 Prof. RNDr. Jan Cerny, DrSc. – CZ  
 Prof. Eduard I. Danilenko, DrSc. – UA  
 Prof. Ing. Branislav Dobrucky, PhD. – SK  
 Prof. Ing. Pavol Durica, CSc. – SK  
 Prof. Dr.hab Inž. Stefania Grzeszczyk – PL  
 Prof. Ing. Mário Guagliano – IT  
 Prof. Ing. Vladimír Hlavna, PhD. – SK  
 Prof. RNDr. Jaroslav Janacek, PhD. – SK  
 Prof. Ing. Hermann Knoflacher – AT  
 Prof. Ing. Mário Guagliano – IT  
 Prof. Ing. Tomas Lovecek, PhD. – SK  
 Doc. RNDr. Mariana Marcokova, CSc. – SK  
 Prof. Ing. Ludovit Parilak, CSc. – SK  
 Prof. Ing. Pavel Polednak, PhD. – CZ  
 Prof. Bruno Salgues – FR  
 Prof. Dr. Mirosław Skibniewski, PhD. – US  
 Prof. Andreas Steimel – DE  
 Prof. Ing. Marian Sulgan, PhD. – SK  
 Prof. Dr. Ing. Miroslav Svitek – CZ  
 Prof. Josu Takala – FI  
 Doc. Ing. Martin Vaculik, PhD. – SK  
 Doc. PhDr. Michal Valco, PhD. – SK

### Address of the editorial office:

Zilinská univerzita  
 Office for Science and Research  
 (OVAV)  
 Univerzitna 1  
 SK 010 26 Zilina  
 Slovakia

E-mail: komunikacie@uniza.sk

Each paper was reviewed by two reviewers.

Journal is excerpted in **COMPENDEX** and **SCOPUS**.

It is published by the University of Zilina in  
 EDIS – Publishing Institution of Zilina University  
 Registered No: EV 3672/09  
 ISSN 1335-4205

Published quarterly

Single issues of the journal can be found on:  
<http://www.uniza.sk/komunikacie>

ICO 00397 563  
 April 2017