

**5**

Gavrilovic S. Branislav

**SIMULATION OF TORSION MOMENT  
AT THE WHEEL SET OF THE RAILWAY  
VEHICLE WITH THE TRACTION  
ELECTROMOTOR FOR WAVY DIRECT  
CURRENT**

---

**10**

Tomas Lack - Juraj Gerlici

**ANALYSIS OF VEHICLES DYNAMIC  
PROPERTIES FROM THE POINT OF VIEW  
OF PASSENGER COMFORT**

---

**19**

Jaromir Siroky

**SYSTEMATIC TIME TABLES - MODELLING  
OF TRAINS' PATHS BY USING GENETIC  
ALGORITHMS**

---

**26**

Juraj Gerlici - Tomas Lack

**MODIFIED HHT METHOD USAGE  
FOR VEHICLE VIBRATION ANALYSIS  
IN TIME DOMAIN**

---

**33**

Peter Faith

**PASSENGER ROAD TRANSPORT TRENDS  
IN THE SLOVAK REPUBLIC**

---

**40**

Jozef Jandacka - Stefan Papucik - Vladimir Dekys -  
Richard Melicher

**AN ANALYSIS OF AIR FLOW AT VARIOUS  
SPACING OF FANS ON A PHYSICAL MODEL  
OF A ROAD TUNNEL**

---

**45**

Miloslav Klinko - Juraj Grecik

**TILTING BODY VEHICLES ON SLOVAK  
RAILWAYS - POTENTIAL FOR USE AND  
PARAMETERS TO BE CONSIDERED**

---

**50**

Bojan Cene - Aleksandar Radosavljevic -  
Branislav Gavrilovic

**DRIVING ENERGY CONSUMPTION  
OF ELECTRIC TRACTION VEHICLES**

---

**57**

Radomir Brkic - Zivoslav Adamovic

**THE IMPLEMENTATION OF SAFETY AND  
RELIABILITY OF DATA TRANSMISSION IN  
RAILWAY SIGNALLIZATION SYSTEMS**

---

**61**

Jan Krmela

**COMPUTATIONAL MODELLING OF TYRES  
CONSIDERING OPERATING AND SAFETY  
REQUIREMENTS**

---

**66**

Jarmila Sosedova - Jan Slesinger - Miroslav Bariak

**TELEMATICS IN INLAND NAVIGATION**

---

**69**

Ivana Olivkova

**PASSENGER INFORMATION SYSTEMS  
IN PUBLIC TRANSPORT**

---

**72**

Tatiana Olejnikova

**TWO AND THREE-REVOLUTION CYCLICAL  
SURFACES**

---



*Dear reader,*

*Research and technology developments have an important role to play and are providing the Europe Transport System with innovative vehicles and transport technology and a new form of transport organisation and infrastructure. The successful future of transport depends on the use of different modes of transport. An effective system is one that is sufficiently flexible to identify and respond to users' needs appropriately. The journal Communications - Scientific Letters of the University of Zilina provides opportunity for publishing scientific and research findings.*

*This issue of the journal is devoted to transport. Reading the papers you can know more about the problems of the simulation of railway vehicles, passenger comfort, timetables modelling, vehicle vibration, road passenger transport trends in the Slovak Republic, physical model of a road tunnel, tilting body vehicles on the Slovak Railways, driving energy consumption, railway signalisation, road vehicle tyres, inland navigation, passenger information systems and cyclical surfaces.*

*We hope that the scientific and research findings of transport will be on the pages of the Communications more frequently. The editorial board of our journal is looking forward to all experts who deal with transport problems to publish their scientific and research outcomes.*

*Pavel Surovec*

Gavrilovic S. Branislav \*

## SIMULATION OF TORSION MOMENT AT THE WHEEL SET OF THE RAILWAY VEHICLE WITH THE TRACTION ELECTROMOTOR FOR WAVY DIRECT CURRENT

The phenomenon of mechanical resonance in the axial make of the railway vehicle with the traction electromotors for wavy direct current has been of topical interest for the railway connoisseurs for a long time. This is not randomly because mechanical resonance may cause crevices and fractures in the wheel set. Accordingly mechanical resonance may endanger safety of railway communication. However, previous research did not precisely investigate the influence of tension and current at the value and guise of torsion moment at the wheel set. Therefore, this paper defined adduced influence. Besides, this paper defined the optimal antislippage shield for all the railway vehicles with the traction electromotors for wavy direct current.

### 1. Introduction

Within the capital reparation of the diode ZS 441 series locomotives in 2006 and 2007, the modification of electric devices was realised. The modification of the diode ZS 441 series locomotives was realised at the electric devices because the Directorate of

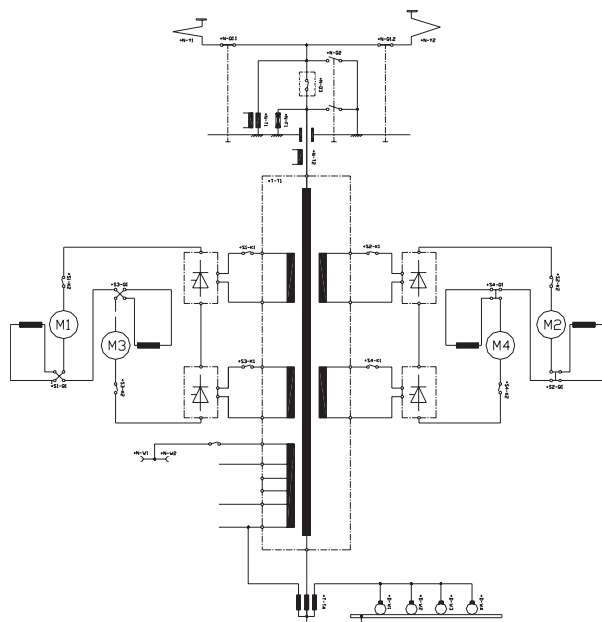

Fig. 1 Simplified traction circuit of the thyristor ZS 444 series locomotives

»Serbian Railway« wanted a greater reliability in service and better environment for the railway motorman. In the modification the hightension tuner was ejected because the diode bridge was replaced with the halfconduct tiristore bridge. The traction circuit of the thyristor ZS 444 series locomotives was realised with two bimotor units. The first and the second bimotor unit comprised M1 and M3 and M2 and M4 traction electromotors for wavy direct current at the separate rotary socle. Accordingly, all wheel sets of the ZS 444 series locomotives have got the equal performance. Traction electromotors for wavy direct current in each bimotor unit are connected in a series - Fig. 1.

For the purpose of a precise analysis of the influence of wavy direct current on the value and guise of torsion moment at the wheel set we apply the operational method based on Laplace's transformation. This method will be described in the subsequent article.

### 2. Dynamics at the Wheel set of the Thyristor ZS 444 Series Locomotives

The propulsion system of the thyristor ZS 444 series locomotives is a mechanical system which comprises the traction electromotor for wavy direct current (3), a cogged clamp (2), a cardan shaft (5), a rubber clamp, a reductor (1), the driving shaft (4) and a monoblock wheel (Fig. 2) [1, 2].

The essential running of the mechanical system is a rotation with a transfer of operative moment from the shaft of the traction electromotor to the monoblock wheel. Researches have shown that the described mechanical system may generate a strong torsion oscillation and fracture of the wheel set [1, 2].

\* Gavrilovic S. Branislav  
Railway College, Belgrade, Serbia, E-mail: brane23@sbb.co.yu

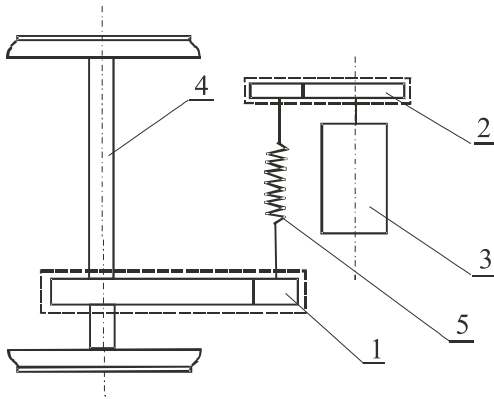

Fig. 2 Propulsion system of the thyristor ZS 444 series locomotives

The dynamic balance of the shaft of the traction electromotor for wavy direct current is described by the next equation [1, 2, 3]:

$$J_m \frac{d\omega}{dt} = M - M_m \quad (1)$$

where  $J_m$  is the inertial moment of rotating mass with the angular speediness  $\omega$ . The inertial moment  $J_m$  is a sum of inertial moment of the traction electromotor for wavy direct current ( $550 \text{ Nms}^2$ ), inertial moment of the cogged clamp ( $2 \text{ Nms}^2$ ), inertial moment of the cardan shaft ( $3 \text{ Nms}^2$ ), inertial moment of the rubber clamp ( $10 \text{ Nms}^2$ ) and inertial moment of the lesser gear of the jagged reductor ( $10 \text{ Nms}^2$ ). Therefore, the inertial moment is  $J_m = 575 \text{ Nms}^2$  [3];  $\omega$  - angular speediness of the shaft of the traction electromotor for wavy direct current;  $M(t)$  - transient value of torque at the shaft of the traction electromotor for wavy direct current;  $M_m(t)$  - transient value of torque oncoming from idler force;  $D$  - diameter of the monoblock wheel ( $D = 1210 \text{ mm}$ );  $i$  - transfer ratio of the jagged reductor ( $i = 3.65$ ).

Fig. 3 shows the courses of the operative moment  $M_0$  and the torque  $M_v$  of the reaction force

$\vec{F}_v (\vec{F}_v = -\vec{F}_v')$ .  $J_0$  in Fig. 3 denominates the inertial moment of rotating mass with the angular speediness  $\omega_0$ . The inertial moment  $J_0$  is the sum of inertial moment of the larger gear of the jagged reductor ( $180 \text{ Nms}^2$ ); inertial moment of the driving shaft ( $340 \text{ Nms}^2$ ) and inertial moment of the monoblock wheel ( $1600 \text{ Nms}^2$ ). The total inertial moment is  $J_0 = 2120 \text{ Nms}^2$  [3].

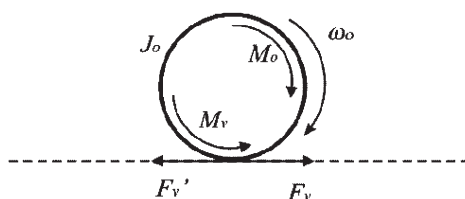

Fig. 3 Courses of the operative moments  $M_0$  and the torque  $M_v$

The equation of dynamic balance for the shown system in Fig. 3 is:

$$J_0 \frac{d\omega_0}{dt} = M_0 - M_v \quad (2)$$

where

$$\omega_0 = \frac{2}{D} \cdot v = \frac{\omega}{i} \quad (3)$$

$$M_0 = \eta \cdot i \cdot M_m \quad (4)$$

$$M_v = \frac{D}{2} \cdot F_v \quad (5)$$

$\eta = 0.975$  (grade of utility according to the IEC - 349)

Based on equations (1) and (4):

$$J_m \frac{d\omega^*}{dt} = \frac{M_m}{\omega_n} (M^* - M_0^*) \quad (6)$$

where  $M_{0b} = M_{0n} = \eta \cdot i \cdot M_m = 27924.8849 \text{ Nm}$

Based on equations (2) and (5):

$$J_m \frac{d\omega_0}{dt} = M_0 - \frac{D}{2} \cdot F_v \quad (7)$$

The equation of the mechanical system running is:

$$m \frac{dv}{dt} = F_v - \Sigma F_{ot} \quad (8)$$

where:  $m$  - mass of each wheel set;  $\Sigma F_{ot}$  - total reaction forces ( $\Sigma F_{ot}$  is the sum of friction force of the wheel-rail system; friction force in a shaft bolster; friction force of air; reaction force on a slope; reaction force on a curvature and reaction force of inertia of locomotive).

Based on the former equations:

$$\left( J_0 + m \cdot \left( \frac{D}{2} \right)^2 \right) \frac{d\omega_0^*}{dt} = \frac{M_{0n}}{\omega_{0n}} (M_0^* - M_{Fv}^*) \quad (9)$$

where:  $\omega_{0n} = \frac{\omega_n}{i} = 35.8438 \frac{\text{rad}}{\text{s}}$ ;  $M_{Fv}^* = \frac{D}{2} \frac{\Sigma F_{ot}}{M_{0n}}$  - comparative value of the reaction momentum.

Based on the equations (6) and (9), the angular speedinesses  $\omega$  and  $\omega_0$  have got forms in the complex domain:

$$\omega = \frac{M_m \cdot (M^* - M_0^*)}{J_m \cdot \omega_n \cdot s} \quad (10)$$

$$\omega_0 = \frac{M_{0n} (M_0^* - M_{Fv}^*)}{\left( J_0 + m \left( \frac{D}{2} \right)^2 \right) \cdot \omega_{0n} \cdot s} \quad (11)$$

The torsion moment of the driving shaft (4) - Fig. 2:

$$M_r = k \cdot \Delta\theta \quad (12)$$

$$\Delta\theta = \frac{1}{i}\theta - \theta_0 \quad (13)$$

$$\omega_0 = \frac{d\theta_0}{dt} \text{ in the complex domain } \theta_0 = \frac{\omega_0}{s} \quad (14)$$

$$\omega = \frac{d\theta}{dt} \text{ in the complex domain } \theta = \frac{\omega}{s} \quad (15)$$

where  $k$  - torsion constant of driving shaft (4) - Fig. 2. The torsion constant of the leaves part of the driving shaft (i.e. part of the driving shaft from the jagged reductor to the near monoblock wheel) is  $k_1 = 553 \cdot 10^6 \text{ Nm} \cdot \text{rad}^{-1}$ . Torsion constant of the longer part of the driving shaft (i.e. part of the driving shaft from the jagged reductor to the further monoblock wheel) is  $k_2 = 9.8 \cdot 10^6 \text{ Nm} \cdot \text{rad}^{-1}$  [3];  $\theta_0$  - banking of driving shaft (4) induced by the wheel-rail system.

### 3. Resonance Frequency of the wheel set

As

$$\theta_0 = \frac{\frac{k}{i}}{\left(J_0 + m \cdot \left(\frac{D}{2}\right)^2\right) \cdot s^2 + k} \quad (16)$$

transfer function  $W_M$  is:

$$W_r = \frac{M_r}{M} = \frac{1}{\left(J_m \cdot k + \frac{k}{\eta \cdot i^2} \left(J_0 + m \cdot \left(\frac{D}{2}\right)^2\right)\right) \cdot s^2} \cdot \frac{\frac{k}{i} \left(J_0 + m \cdot \left(\frac{D}{2}\right)^2\right) \cdot s^2}{\left( \frac{J_m \cdot \left(J_0 + m \cdot \left(\frac{D}{2}\right)^2\right)}{J_m \cdot k + \frac{k}{\eta \cdot i^2} \left(J_0 + m \cdot \left(\frac{D}{2}\right)^2\right)} \cdot s^2 + 1 \right)} \quad (17)$$

The dominant poles of the transfer function  $W_M$  define the resonance frequency of the wheel set. The resonance frequency of the wheel set is determined by the next equation:

$$\omega = \sqrt{\frac{J_m \cdot k + \frac{k}{\eta \cdot i^2} \left(J_0 + m \cdot \left(\frac{D}{2}\right)^2\right)}{J_m \cdot \left(J_0 + m \cdot \left(\frac{D}{2}\right)^2\right)}} \quad (18)$$

Based on the equation (18), resonance frequencies of the leaves and longer of the driving shaft (4) - Fig. 2 - are:

$$\omega_1 = 526.87 \frac{\text{rad}}{\text{s}} \quad (19)$$

$$\omega_2 = 70.14 \frac{\text{rad}}{\text{sec}} \quad (20)$$

### 4. Torsion moment at a Slippage of the Wheel set

Based on the former equations, we made a program in MATLAB-SIMULINK to simulate the torsion moment at the wheel set. We received a chronological variety of the torsion moment of the longer part of the driving shaft according to Fig. 4 when we started from this simulation program. We assumed that a slippage of the wheel set appeared because of a nuisance value of the traction

coefficient at  $M_{F_{vs}} = \frac{D}{2} \Sigma F_{ot} = 1$  (The traction coefficient at

this environment is defined by the following term:  $F_v > \mu \cdot Q_c \implies$

$$\mu < \frac{M_{0n}}{\frac{D}{2} \cdot Q_c} = \frac{27924.8849}{\frac{1.21}{2} \cdot 200000} = 0.23).$$

We also assumed that the rotating moment of the shaft of the traction electromotor for wavy direct current is determined by:

$$M(t) = \frac{33}{32} \cdot k_0 \cdot I_{sr}^2 \left( 1 + \frac{16}{33} \cos 2\omega t + \frac{1}{33} \cos 4\omega t \right) = (21)$$

$$= M_{sr} (1 + a_1 \cos 2\omega t + a_2 \cos 4\omega t)$$

where  $M_{sr}$  - in between value of the torque of the shaft of the traction electromotor for wavy direct current;  $a_1 = 16/33$  - factor amplitude of a frequency  $2f = 2 \cdot 50 = 100 \text{ Hz}$ ;  $a_2 = 1/33$  - factor amplitude of a frequency  $4f = 4 \cdot 50 = 200 \text{ Hz}$ .

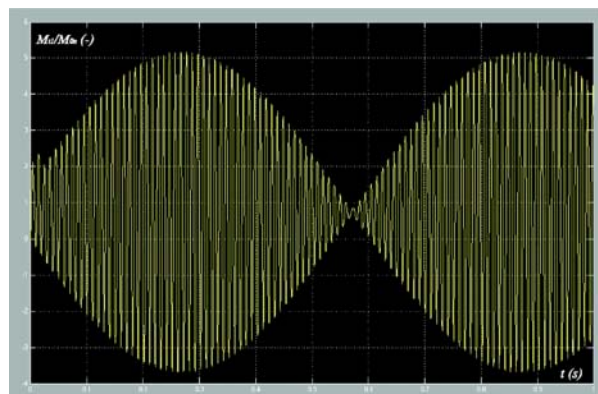

Fig. 4 Comparative value of the torsion moment of the longer part of the driving shaft at  $a_1 = 16/33$  of a frequency during  $2f = 2 \cdot 50 = 100 \text{ Hz}$  the slippage of the wheel set

Based on Fig. 4, we can conclude that the torsion moment of the longer part of the driving shaft quite quickly rises during the slippage of the wheel set. This moment achieved the value of  $M_{r1}/M_{0n} = 23$  ( $M_{r1} = 6.42$  MNm) in a quite short period of  $t \leq 0.3$  s. Consequently, the torsion moment during the slippage of the wheel set will permanently impair the longer part of the driving shaft.

If we curtail the value of the factor amplitude of a frequency  $2f = 2 \cdot 50 = 100$  Hz from  $a_1 = 16/33$  to  $a_1 = 0.1$ , the dependence  $M_{r1}/M_{0n} = f(t)$  during the slippage of the wheel set will be according to Fig. 5. (The factor amplitude  $a_1$  may dwindle if we enlarge inductance of central silencer).

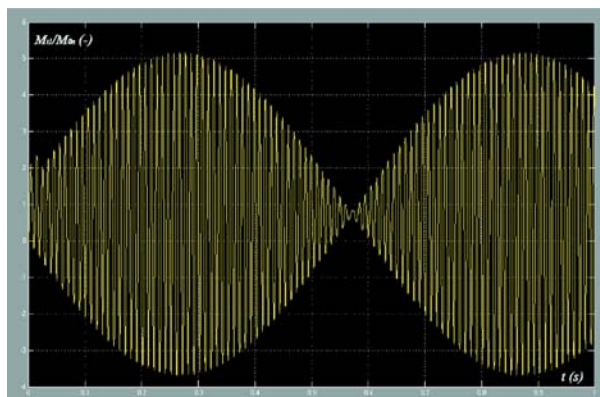

Fig. 5 Comparative value of the torsion moment of the longer part of the driving shaft at  $a_1 = 0.1$  of a frequency  $2f = 2 \cdot 50 = 100$  Hz during the slippage of the wheel set

Based on Fig 5, we can conclude that the torsion moment at  $a_1 = 16/33$  is five times smaller than the torsion moment  $a_1 = 0.1$  at during the slippage of the driving wheel set. The peak value of the torsion moment of the longer part of the driving shaft at  $a_1 = 0.1$  is attained in  $t = 0.25$  s. Besides, our program for simulation showed that the peak value of this moment further dwindled while we were further dwindling the factor amplitude of a circular frequency  $2f = 2 \cdot 50 = 100$  Hz.

If we commute the diode or asymmetrical thyristor rectifier with the symmetrical thyristor rectifier, we'll receive a passable value of the torsion moment with the frequency  $2f = 2 \cdot 25 = 50$  Hz. The dependence  $M_{r1}/M_{0n} = f(t)$  during the slippage of the wheel set with the frequency  $2f = 2 \cdot 25 = 50$  Hz and  $a_1 = 3$  is shown in Fig. 6.

Based on Fig. 6, we can conclude that the substitution of the diode rectifier or the asymmetrical with modern symmetrical thyristor rectifier relates to a passable value of the torsion moment during the slippage of the wheel set. Besides, this substitution will

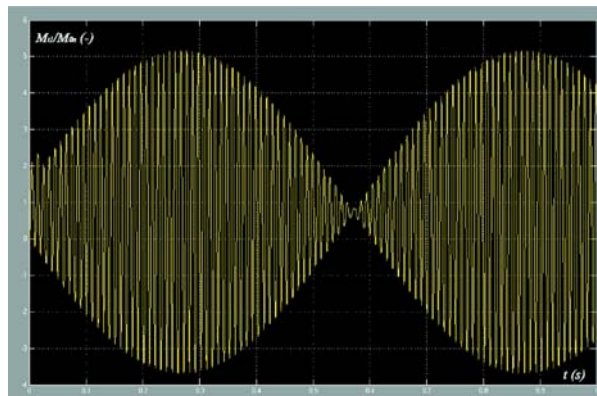

Fig. 6 Comparative value of the torsion moment of the longer part of the driving shaft at  $a_1 = 3$  of a frequency  $2f = 2 \cdot 25 = 50$  Hz during the slippage of the wheel set

eject the cascade switch and simplify the traction transformer. This substitute may also enable the application of recuperative brake. Consequently, we believe that the modern symmetrical thyristor rectifier may eliminate the impairing of the longer part of the driving shaft during the slippage. With this rectifier the existing antislippage shield of the ZS 441, ZS 461 and ZS 444 electrolocomotives will be enough speedy though now it is not.

### 5. Conclusion

The torsion moment of the longer part of the driving shaft rises quite quickly during the slippage of the wheel set. This moment was achieving the value of  $M_{r1}/M_{0n} = 23$  ( $M_{r1} = 6.42$  MNm) in quite a short period of  $t \leq 0.3$  s. Consequently, torsion moment during the slippage of the wheel set will permanently impair the longer part of the driving shaft.

The torsion moment of the longer part of the driving shaft at  $a_1 = 16/33$  is five times smaller than the torsion moment at  $a_1 = 0.1$  during the slippage of the wheel set. The peak value of the torsion moment of the longer part of the driving shaft at  $a_1 = 0.1$  is attained in  $t = 0.25$  s. Besides, our program for simulation showed that the peak value of this moment further dwindled while we were further dwindling the factor amplitude of a frequency  $2f = 2 \cdot 50 = 100$  Hz.

The substitution of the diode rectifier or the asymmetrical with modern symmetrical thyristor rectifier relates to a passable value of the torsion moment with the frequency  $2 \cdot f = 2 \cdot 25 = 50$  Hz during the slippage of the wheel set. Besides, this substitution will eject the cascade switch and simplify the traction transformer. This substitution may also enable the application of recuperative brake. Consequently, we believe that the modern symmetrical thyristor rectifier may eliminate the impairing of the longer part of the driving shaft during the slippage.

**References**

- [1] JOVANOVIĆ, R.: *Tension status of locomotive shaft in exploitation situation*, PhD dissertation, Mechanical Engineering Faculty, Belgrade, 1978.
- [2] JOVANOVIĆ, R.: *Causes, appearances and odds eliminating some splits and mishaps of the operative shaft (axle) of the rail vehicles*“, Research project MIN, Institution „Edvard Kardelj“, Nis, 1987.
- [3] JANJANIN, S.: *Identification of some reasons for torsional moment of the operative system of 441 locomotive with the analogue computer*, The Community of Yugoslav Railways, Study, Zagreb, 1974.
- [4] GAVRILOVIĆ, S. B.: *Motivity moment of the traction electromotor of the thyristoring JZ 444 series locomotives*, Proc. of 5<sup>th</sup> Intern. Scientific Conference on Production Engineering, pp. 553–558, ISBN 99589262-0-2, Bihac, BIH, 2005.

Tomas Lack – Juraj Gerlici \*

## ANALYSIS OF VEHICLES DYNAMIC PROPERTIES FROM THE POINT OF VIEW OF PASSENGER COMFORT

*The passenger ride comfort can be assessed via the indexes of comfort i.e. via the indirect method in accordance with the European standard ENV 12299: 1999 or 2006. This method is based on the values of accelerations knowledge in the analysed places of vehicle body. The signal of accelerations is filtered and weighted with functions that take into account the sensitivity of human body to the vehicle body vibrations in reference directions. The signal is statistically assessed and the ride comfort indexes for floor, sitting or standing positions are evaluated. The accelerations coming into the assessment of ride comfort indexes can be obtained from measurements or as results of a computer simulation. The paper deals with the accelerations analysis and their influence on the final comfort index.*

*Key words: ride comfort index, computer simulation, kinematic excitation, nonlinear computational model*

### 1. Introduction

The passenger ride comfort presents a very important and up-to-date issue. The passenger ride comfort is the basic presupposition of a commercial benefit for cars and railway vehicles operators and a criterion of attractiveness for passengers of this transport form. The exploitation of computer simulation and detail computer analyses of measured experimental data allow a decrease in experimental tests size. Expenses for the development of new vehicles construction and re-construction are being decreased as well.

The aim of the authors was to apply the assessment procedures of passenger ride comfort in a rail vehicle through the “indirect” method (via the numerical processing of accelerations values). This is the way how to obtain the final value of the comfort index. The advantage of the method is that the analysis takes into account only the vehicle/track couple quality and the results are not influenced by subjective feelings of passengers. The analysis of the flexible binding member parameters and their influence on ride comfort indexes must be taken into account as well.

### 2. Passenger comfort

Comfort is a complex sensation produced during the application of oscillations and/or inertia forces, via the whole-body transmission caused by vehicle-frame movements [1, 12]. It is defined and measured through comfort indexes as:

- Mean comfort: a mean feeling, continuously adjusted, as evaluated through a measurement following the procedures for comfort index  $N_{MV}$  and indexes  $N_{VA}$  and  $N_{VD}$ .

- Comfort on Curve Transition: discomfort, due to a perceived curve entry or reverse transition, quantified by the recommended procedure indicated as comfort index  $P_{CT}$ .
- Comfort on Discrete Events: discomfort, due to a perceived transient oscillation on a straight track, curves and curve transitions, qualified by the recommended procedure indicated as comfort index  $P_{DE}$ .

Comfort indexes assessment procedures utilised for the computation are introduced by authors in detail in [4].

### 3. Accelerations in vehicle acting on passengers

The accelerations values necessary for “comfort for passengers” assessment may be obtained in various ways. They are mainly based on a direct, in a vehicle body, measurement and on the computer simulation results. We obtained the necessary accelerations information with the help of computer simulations of vehicle under the running conditions.

### 4. Vehicle model parameters

We used the geometric, mass and flexible binding parameters in accordance with known passengers wagon ERRI for a model analysis. This dummy parameters set is commonly used as a specimen example of a simulation analysis in the MSC.ADAMS computational system.

The model was processed with the “DELTA” programme system. The programme system DELTA works on the base of the

\* Tomas Lack, Juraj Gerlici

Faculty of Mechanical Engineering, University of Zilina, Slovakia, E-mail: tomas.lack@fstroj.uniza.sk

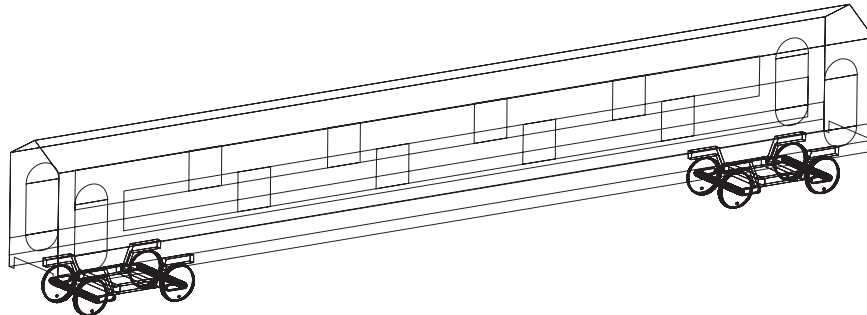

Fig.1 3D model of vehicle (MSC.ADAMS/Rail [10])

finite element method theory. Because of special model parameters setting (in accordance with the ADAMS system), it behaves like the system of no-mass frames. We can proclaim that from the point of view of commercial programme packages features, the DELTA programme with its working features is closer to the FEM (ANSYS – the Transient analysis part) system than to MBS (ADAMS) system. It is possible to take into account the flexibility of modelled bodies when the real stiffness and cross-sections parameters are known and set as input parameters for a computation. The programme was built in the environment of the programme language DELPHI for an operation in the environment of the MS Windows XP operational system. It was designed on the base of an opened component system. The programme DELTA allows performing static and dynamic mechanical systems analyses. An input of data of a vehicle mechanical system is carried out with the help of node points and elements: a linear spring, nonlinear spring, a beam, a linear damper, nonlinear damper and mass point.

**Boundary and starting conditions:**

- prescribed displacements, velocities and accelerations of nodes;
- prescribed revolutions, angular velocities and angular accelerations of nodes;
- prescribed forces and torques acting in nodal points;
- prescribed accelerations acting on a vehicle.

**Methods for dynamics solution:**

- the eigenfrequencies and eigenvectors assessment with the help of Jacobi's rotation method;
- a response analysis evoked by harmonic excitation;
- a direct solution of a model oscillation in the time domain with the following methods: the differential method, the HHT- method, the method of linear accelerations, the Newmark method, the Wilson- method and the Crank-Nicolson method.

Equations solution methods (solver) are Frontal elimination and L-U decomposition.

The output is graphical and textual. The eigenfrequencies and eigenvectors assessment was performed with the Jacobi's rotation method. A response analysis from harmonic excitation and a direct solution of model oscillation were performed in the time domain.

The Newmark modified method was used for the direct solution in the time domain. This method is known as the "HHT-

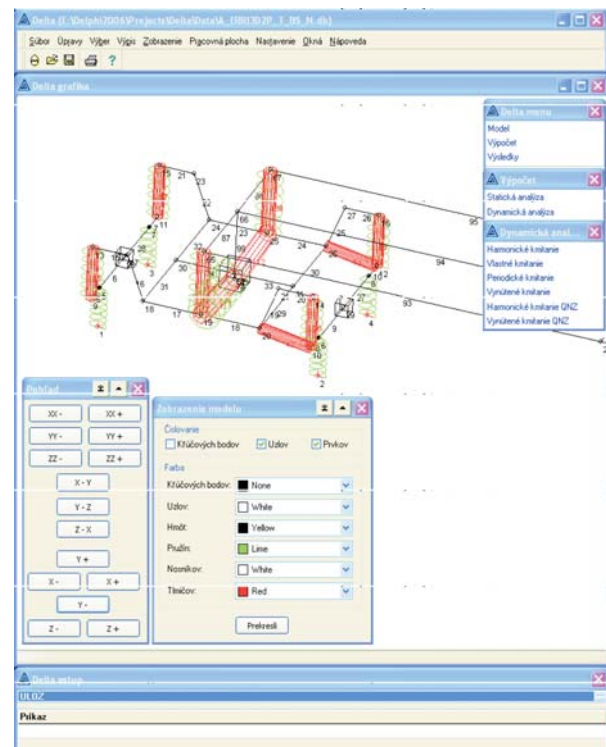

Fig.2 The DELTA programme main screen when the menu are opened

method". The method was modified for the solution of dynamic systems with nonlinear members. The usage of this method has been recently very relevant in the field of technical computations performance. The main advantage is in the decrease of time which is necessary for computing. The linear algebraic equations system was computed with the help of the Frontal elimination method. This method is suitable for big systems of linear equation solution, known in connection with numerical analyses based on the Finite element method theory. The computational model was built up from 80 nodal points and 132 elements. The model has 456 degrees of freedom, the computational front width is 66. All the amount of track sections is 257, which represents the 1285 seconds of vehicle running.

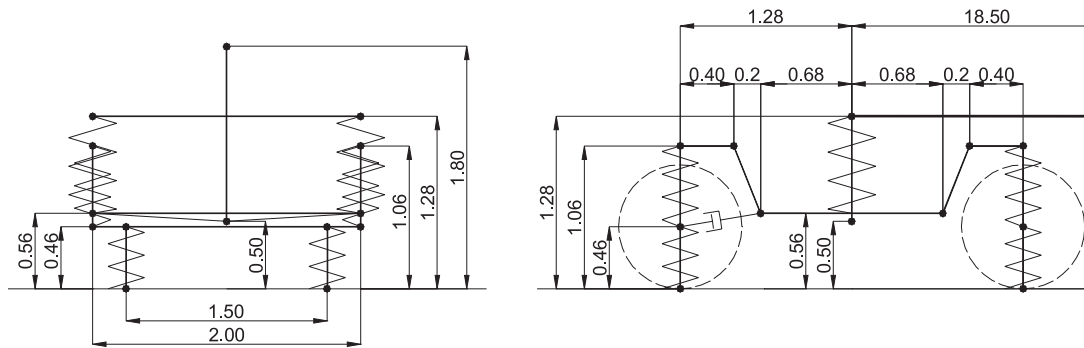

Fig. 3 Geometrical parameters of chosen dynamic model of vehicle in accordance with [10]

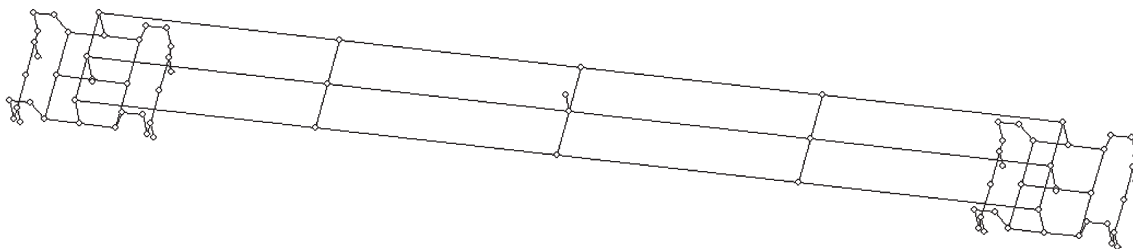

Fig. 4 The whole vehicle model (DELTA)

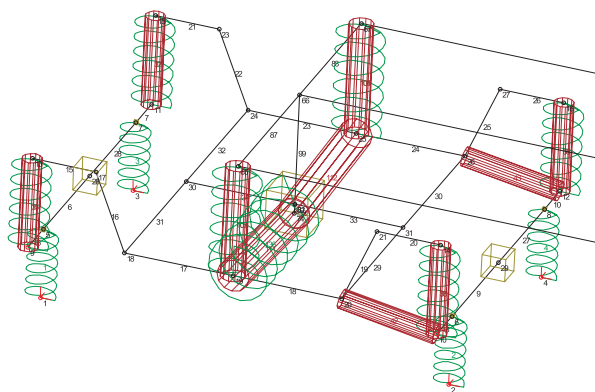

Fig. 5 The rear bogie with depicted construction elements, 2. bogie (DELTA)

The list of some important eigenfrequencies is processed in the following table. The eigenvectors due to these frequencies representation is in the following figures as well.

Other eigenfrequencies and to them pertaining eigenvectors are not important from the point of this analysis. The reason is that they represent deformations of "rigid" structures of the model (bogies frames or a vehicle body). The frequencies are out of analysis limits in the time domain where  $s$ , which corresponds to the 200 Hz frequency.

The dominant oscillation shapes specification

Tab. 1

Consecutive number	Eigen angle velocity Omega [1/rad]	Eigen-frequency f [Hz]	Dominant form of eigenvector
1.	3.8846	0.618	Lower swaying
2.	4.1525	0.661	Longitudinal oscillation
3.	5.602	0.892	Yawing
4.	5.8127	0.925	Upper swaying
5.	6.2382	0.993	Bouncing
6.	7.345	1.169	Pitching
7.	28.5857	4.55	Swaying of individual bogies in opposed directions
8.	28.7195	4.571	Swaying of individual bogies in a concurrent way
9.	29.3639	4.673	Pitching of individual bogies in opposed directions
10.	29.4082	4.68	Pitching of individual bogies in a concurrent way

### 5. Verification of nonlinear model

The vehicle in a real operation has its special parameters. In general it is characterised by its own properties. For a reliable vehicle

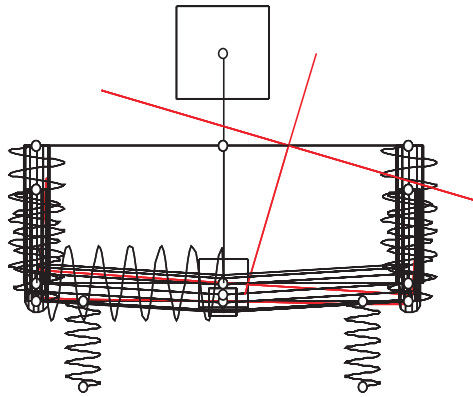

Fig. 6 1. eigenvector when the eigenfrequency is 0.618Hz

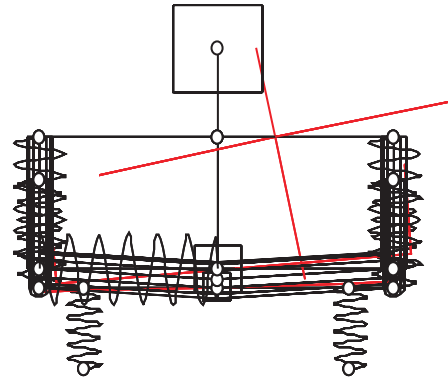

Fig. 9 4. eigenvector when the eigenfrequency is 0.925Hz

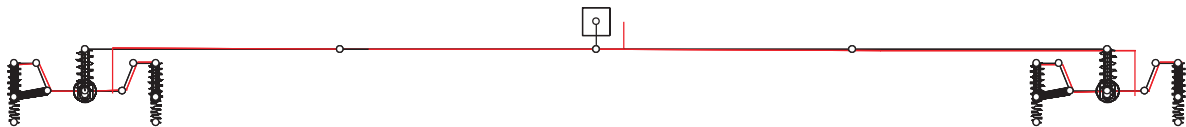

Fig. 7 2. eigenvector when the eigenfrequency is 0.661Hz

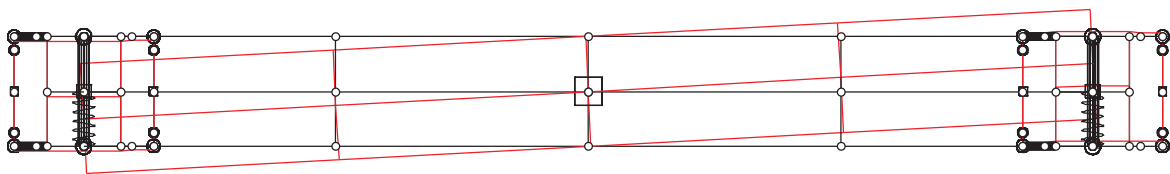

Fig. 8 3. eigenvector when the eigenfrequency is 0.892Hz

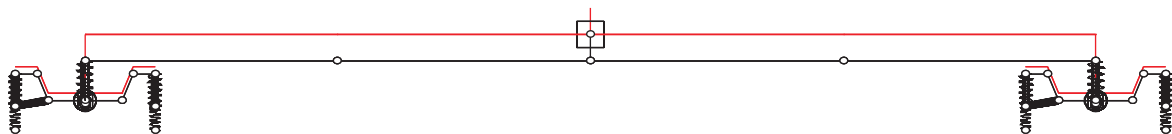

Fig. 10 5. eigenvector when the eigenfrequency is 0.993Hz

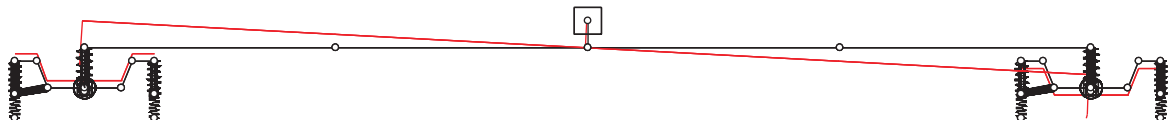

Fig. 11 6. eigenvector when the eigenfrequency is 1.169Hz

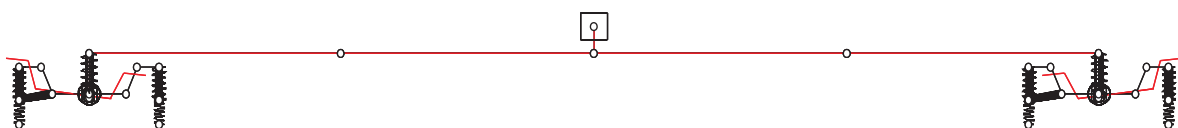

Fig. 12 9. eigenvector when the eigenfrequency is 4.673Hz - pitching of individual bogies in opposed directions

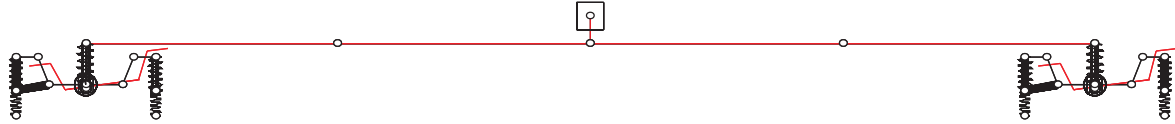

Fig. 13 10. eigenvector when the eigenfrequency is 4.68Hz - pitching of individual bogies in a concurrent way

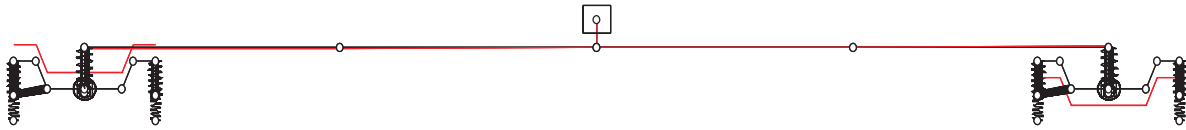

Fig. 14 12. eigenvector when the eigenfrequency is i 5.465Hz - bouncing of individual bogies in opposed directions

properties assessment and behaviour judgement we are to verify the trustworthiness of its computational model.

1. The computation with linear members in the time and frequency domains – provides a rough outline.
2. Non-linear members do not have features of members (in any point of the characteristics) when a deformation is increasing or a deformation velocity is increasing. It may happen that the internal force is decreasing or is maintained on an initial internal force value level.
3. Energetic balance:

$$\Delta\Pi = \Pi(q + \delta q) - \Pi(q) = \delta q^T \cdot (F - R) + \frac{1}{2} \delta q^T \cdot K_i \cdot \delta q = \delta\Pi + \delta^2\Pi \quad (1)$$

$$\Delta\Pi \doteq \delta^2\Pi = \frac{1}{2} \delta q^T \cdot K_i \cdot \delta q$$

- $\Pi$  - is the energy
- $q$  - is the vector of generalised movements
- $K$  - is the tangential stiffness matrix
- $F$  - is the vector of internal forces
- $R$  - is the vector of external loads

For all the vectors is valid

$$\delta q \text{ is } \Delta\Pi > 0 \quad (2)$$

4. The parameters of stability choice of the HHT method an amplitude decreasing ratio  $\gamma \rightarrow (0 \div 1/3) = 0.15$  (3)

$$\alpha = \frac{1}{4}(1 + \gamma)^2; \delta = \frac{1}{2} + \gamma; \alpha_f = \gamma; \alpha_m \leq \alpha_f \quad (4)$$

5. A vehicle model - an examination whether a computational model with its parameters and excitation parameters corresponds to the reality and whether the results of computations are valid.

**In our case we will perform the model verification with the help of a comparison of theoretic characteristics of flexible bindings members with the corresponding values of forces obtained from computations.**

We put the spring of high stiffness in a serial way into the model. The spring in the place of a nonlinear member evaluates the current value of an internal force due to velocity, or change of position of the nonlinear member boundary points. In an ideal case the depicted result is the same as the theoretically requested characteristic curve.

We analysed the dynamic properties of a “common model” vehicle with overtaken parameters [10]. We were looking for the acceleration evaluation on the vehicle with the purpose of defined kinematic excitation and when the acceleration acts due to the track geometry. No classic rail/wheel contact model was used for the analysis in spite of the fact that the authors are interested in various types of contact model evaluation.

## 6. Modelling of excitation

### 6.1. Acquired track parameters from measurement

The input parameters for the excitation of a vehicle mechanical system are: given (measured) geometric layout deviations  $Y_L, Y_p, Z_L, Z_p$ , vehicle velocity  $V$ , cant  $U$ , track curvature  $K$ , track  $s$ , time  $t$ ,  $w(x)$  is a track gauge that is evaluated according to the following relation:

$$w = 1435 + Y_L(x) - Y_p(x) \quad (5)$$

- A vehicle is influenced by these accelerations:

$$a_x = \frac{dv}{dt}, \quad (6)$$

$$a_y = a_b \cdot \cos \alpha, \quad (7)$$

$$a_z = a_b \cdot \sin \alpha, \tag{8}$$

where

$$a_b = -v^2 \cdot K, \alpha = \arctg \frac{U}{1500}, v = \frac{V}{3.6} \tag{9}$$

### 6.2. Kinematic excitation of vehicle in the y-axis direction

The kinematic excitation of the vehicle in the y-axis direction was performed due to the difference of momentaneous rolling radii circles function and wave movement of wheelset with the amplitude of 3 mm and wavelength  $L = 8.647$  m. The wavelength results from the equivalent conicity function for the given contact couple profiles and the amplitude of 3 mm.

$$u_y = u_0 \cdot \sin\left(\frac{2 \cdot \pi \cdot x}{L}\right) + \frac{Y_L(x) + Y_P(x)}{2}, \tag{10}$$

where:

- $u_0$  - is the amplitude of periodical wheelset movement,
- $L$  - is the wavelength of periodical wheelset movement,
- $x$  - is the line performed by the wheelset

### 6.3. Kinematic excitation in the z-axis direction

The kinematic excitation of the vehicle system in the z-axis direction is caused by a vehicle running across the measured uneven-

ness of rails and the difference in momentaneous rolling circles diameters.

#### • Right wheels

$$u_{zr} = Z_r(x) + \Delta R_r(y), y = u_0 \cdot \sin\left(\frac{2 \cdot \pi \cdot x}{L}\right) \tag{11}$$

where

- $u_0$  - is the amplitude of periodical wheelset movement,
- $L$  - is the wavelength of periodical wheelset movement,
- $x$  - is the line performed by the wheelset

$$\Delta R_r(y, w) = |\Delta R(y, w)| \text{ if } y > 0$$

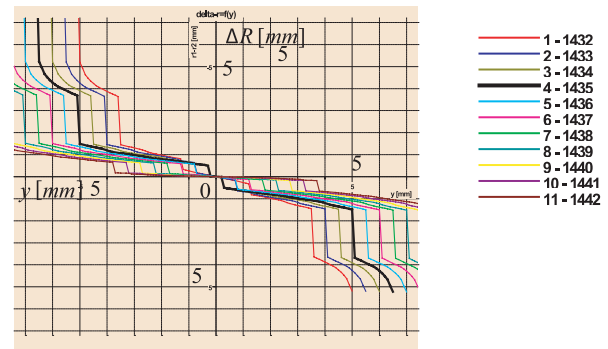

Fig.17 The function for common couple of theoretical profiles (a wheel S1002 and a rail UIC60 with the inclination of 1:40, for various gauge values)

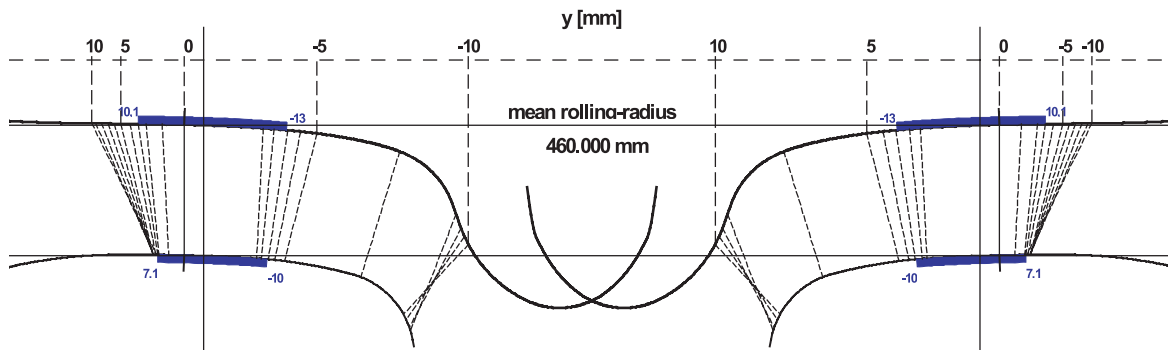

Fig.15 Contact points of S1002/UIC60 profiles couple, for the gauge of 1435 mm

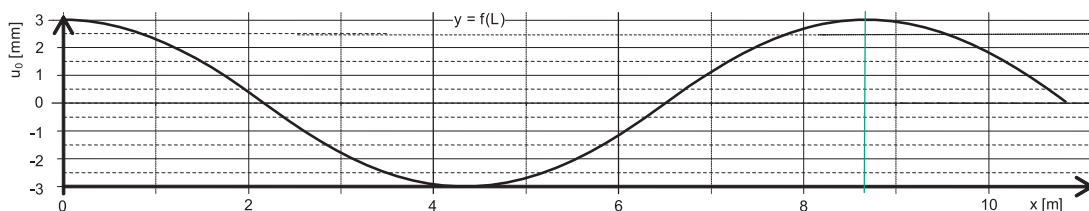

Fig.16 The wavelength of periodical movement of a wheelset with the amplitude of 3 mm

$$\text{and } \Delta R_p(y, w) = 0 \text{ if } y \leq 0 \tag{12}$$

where the  $\Delta R(y, w)$  is the function of differency of momentaneous wheelset wheels rolling circles, computed from the geometrical contact of wheel and rail profiles,  $w(x)$  is a track gauge that is evaluated according to the relation (5).

• **Left wheels**

$$u_{Ll} = Z_L(x) + \Delta R_L(y), \quad y = u_o \cdot \sin\left(\frac{2 \cdot \pi \cdot x}{L}\right) \tag{13}$$

where

- $u_o$  - is the amplitude of periodical wheelset movement,
- $L$  - is the wavelength of periodical wheelset movement,
- $x$  - is the line performed by the wheelset

$$\Delta R_L(y, w) = |\Delta R(y, w)| \text{ if } y < 0$$

$$\text{and } \Delta R_L(y, w) = 0 \text{ if } y \geq 0 \tag{14}$$

where the  $\Delta R(y, w)$  is the function of difference of momentaneous wheelset wheels rolling circles computed from the geometrical contact of wheel and rail profiles,  $w(x)$  is a track gauge that is evaluated according to the relation (5).

**7. Model verification**

The model was verified with the help of the computed and given characteristic curves comparison. The dependance curves between the forces and strain of springs, or between the forces and velocities in the dampers were "measured" in the nonlinear members of the flexible bindings. The parameters of the given characteristic curves were obtained from the literature [10]:

- a damper of primary suspension (MSC.ADAMS) PVD,
- a damper of wheelset turning (MSC.ADAMS) SYD,
- a damper of secondary suspension (MSC.ADAMS) SVD,
- a transversal damper (MSC.ADAMS) SLD,
- a flexible bump stop (MSC.ADAMS) BS.

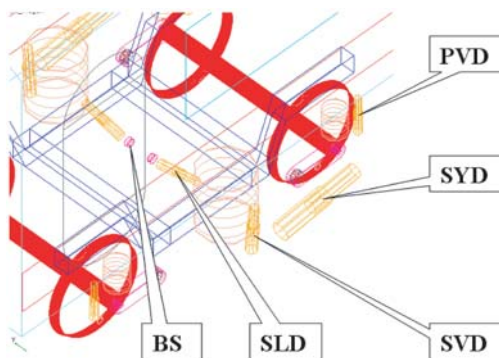

Fig.18 The bogie scheme with flexible bindings

Dampers characteristics [10] Tab. 2

	PVD		SVD		SYD		SLD	
	V	F	V	F	V	F	V	F
	[ms <sup>-1</sup> ]	[N]	[ms <sup>-1</sup> ]	[N]	[ms <sup>-1</sup> ]	[N]	[ms <sup>-1</sup> ]	[N]
1	-1.0	-1000	-1.0	-7100	-1.0	-3.97E4	-1.0	-8500
2	-0.28	-400	-0.26	-3000	-0.14	-1.1E4	-0.305	-4000
3	-0.16	-300	-8.0E-2	-2000	-0.11	-1.0E4	-0.15	-3000
4	-9.0E-2	-200	-4.0E-2	-1775	-5.5E-2	-8000	-7.0E-2	-2000
5	-4.0E-2	-100	-1.5E-2	-1000	-4.0E-2	-7000	-3.0E-2	-1000
6	0.0	0	0.0	0	0.0	0.0	0.0	0.0
7	4.0E-2	100	1.5E-2	1000	4.0E-2	7000	3.0E-2	1000
8	9.0E-2	200	4.0E-2	2000	5.5E-2	8000	7.0E-2	2000
9	0.16	300	8.0E-2	2000	0.11	1.E4	0.15	3000
10	0.28	400	0.26	3000	0.14	1.1E4	0.305	4000
11	1.0	1000	1.0	7100	1.0	3.97E4	1.0	8500

A bump stop characteristic [10] Tab. 3

BS								
	Deformation	F		Deformation	F		Deformation	F
	[m]	[N]		[m]	[N]		[m]	[N]
1	0	0	4	1.5E2	3730	7	3.0E2	1.717E4
2	5.0E-3	600	5	2.0E2	6870	8	3.5E2	2.92E4
3	1.0E-2	1760	6	2.5E2	1.158E4	9	4.0E2	2.3E5

The assessment principle: the forces in nonlinear members were computed as the internal forces in the serial connected linear springs with high stiffness.

The prescribed flexible member characteristics are represented by the curves in the graphs. The linear dependence represents the basic stiffness, or better the basic stiffness constant.

**8. Comfort indexes for a model with nonlinear members**

The computational model with nonlinear members topology shown in the Fig. 21 consists of 80 nodal points and 132 elements. The nodes 67, 77, 73, 80 and 70 create the left side of the vehicle frame, the nodes 65, 22, 71, 78 and 88 create the right side of vehicle frame. The vehicle model moves in the direction from the left to the right side. The Tab. 4 represents the list of computed comfort indexes. These indexes were evaluated under the above mentioned conditions. In Fig. 23 and Fig. 24 there are graphical interpretations of indexes valid for the depicted nodes.

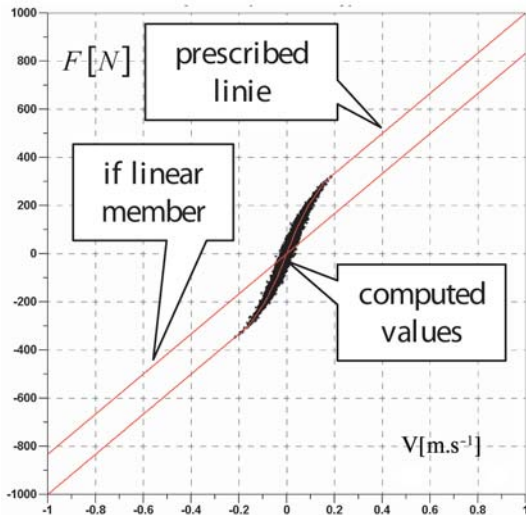

Fig. 19 Forces evaluation in the damper of primary suspension (DELTA)

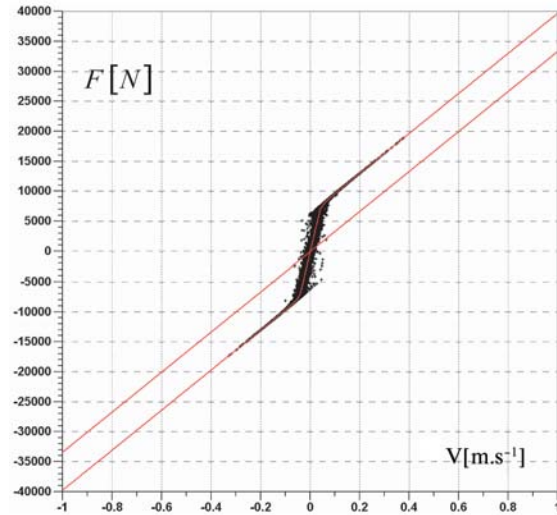

Fig. 20 Forces evaluation in the longitudinal damper (DELTA)

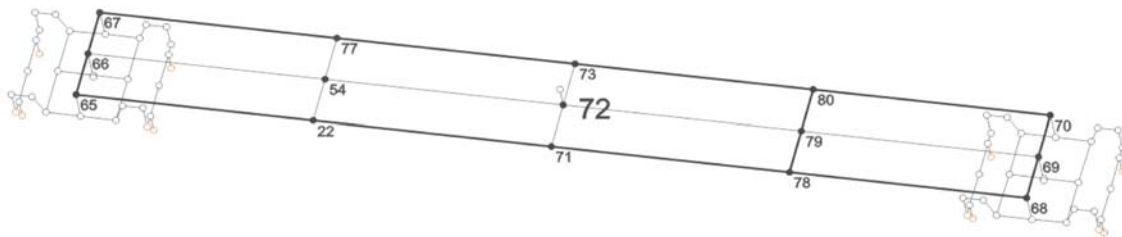

Fig. 21 The node points numbering in the places of indexes evaluation

Passanger comfort indexes for the model with nonlinear members

Tab. 4

	Node	Index floor	Index standing position		Node	Index floor	Index standing position
1	65	2.319	2.205	9	73	1.555	1.692
2	66	2.069	2.18	10	78	1.895	2.038
3	67	2.279	2.207	11	79	1.734	2.012
4	22	1.707	1.763	12	80	1.872	2.04
5	54	1.522	1.709	13	68	2.674	2.74
6	77	1.692	1.737	14	69	2.49	2.716
7	71	1.531	1.691	15	70	2.662	2.742
8	72	1.367	1.662				

### 9. Conclusion

A vehicles dynamics properties analysis is a very wide field. We can process this issue form various points of view. We put our attention in the accelerations calculation. These accelerations input into the relations for passanger ride comfort assessment. The accelerations are commonly measured in the given places of a vehicle body when the vehicle is running. They are filtered, weighted in accordance with the European standards ENV 12999:1999 or prENV 12999:2006 before processing for the comfort indexes evaluation [1, 12]. The accelerations in question can be obtained with the help of a simulation computation [5] as well. The method of mathematical model computation, vehicle parameters and boundary conditions are of great importance for results (accelerations) trustworthiness. In the paper we described one proposal or idea of possible verification of a computational nonlinear model based on a strictly given mechanical system excitation which comes out from real track data. The final accelerations as the vehicle model response from excitation were used as input parameters for the common comfort index evaluation due to the above mentioned European standard.

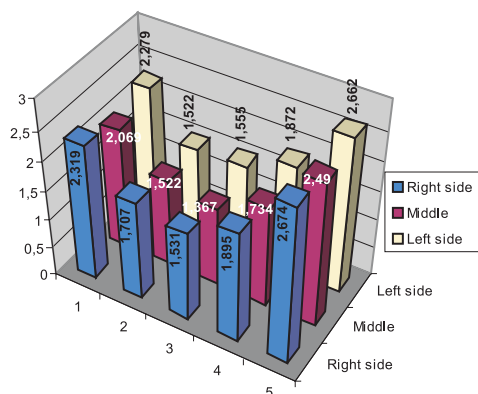

Fig. 22 Comfort for passengers for a floor evaluation, when the vehicle model has nonlinear members

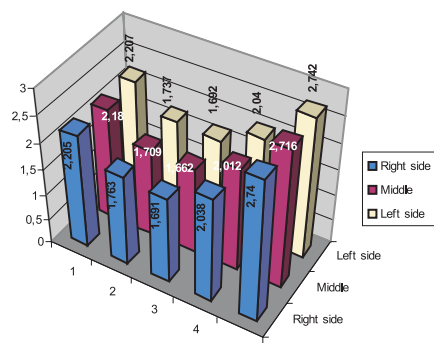

Fig. 23 Comfort for passengers for a standing position evaluation, when the vehicle model has nonlinear members

**Acknowledgement**

The work was supported by the Scientific Grant Agency of the Ministry of Education of the Slovak Republic and the Slovak Academy of Sciences in the project No. 1/3169/06 “Properties

Research of Rail Vehicles in Movement with Emphasis on the Solution of a Wheel and Rail Contact at the Wheelset Rolling in the Rail via Computer Simulation“ and in the project No. 1/4119/07: “Investigation of a dynamical properties of a vehicle“.

**References**

[1] ENV 12299: 1999E *Railway Applications - Ride Comfort for Passengers - Measurement and Evaluation*, European Prestandard, February 1999.

[2] GERLICI, J., LACK, T.: *Methods for Vehicle Vibration Analysis in Time Domain*, Prace naukowe Politechniki Warszawskiej, Z. 63, Transport, 2007, pp. 71-81. Publishing House of the Warsaw University of Technology, ISSN 1230-9265, Warszawa 2007.

[3] GERLICI, J., LACK, T.: *Survey of Ride Comfort for Passengers (in Slovak)*, Acta Mechanica Slovaca, Kosice 4-B/2006, pp. 155-162, Optimization of Mechanical Systems, vol. 10, ISSN 1335-2393, Kosice, 2006.

[4] GERLICI, J., LACK, T., ONDROVA, Z.: *Evaluation of Comfort for Passengers of Railway Vehicles*. Communications - Scientific Letters of the University of Zilina, 4/2007, pp. 44-49, ISSN 1335-4205, EDIS - Publishing house of University of Zilina, 2007.

[5] LACK, T.: *The Dynamic Properties Analysis of Vehicles from the Point of View of Ride Comfort (in Slovak)*, Habilitation Work, pp. 176, Faculty of Mechanical Engineering University of Zilina, 2007.

[6] LACK, T., GERLICI, J.: *Vehicles Dynamical Properties Analysis from the Point of View of Comfort for Passengers*, Archives of Transport, 1-2/2007, pp. 91-110, ISSN 8066-9546, Warszawa 2007.

[7] LACK, T., GERLICI, J.: *The Programme System DELTA Exploitation for Numerical Analysis Performances (in Slovak)*, Proc. of 18th International Conference “Current Problems in Rail Vehicles - PRORAIL 2007” - Part II, pp. 11 22, EDIS, ISBN 978-80-89276-07-3, Zilina, 2007.

[8] LACK, T., GERLICI, J., HLAVNA, V.: *Evaluation of Ride Comfort for Passengers*, pp. 9-13, Horizonty dopravy, ISSN 1210-0978, 5/2006, Special Edition, Transport Research Institute, Zilina 2006.

[9] LACK, T., GERLICI, J., HLAVNA, V.: *The Vehicle Comfort*, Case study, Maintenance and Reliability 2006, ISSN 1507-2711, 4(32)/2006, pp. 89-91, Polskie Naukowo-Techniczne Towarzystwo Eksploatacyjne Warszawa, 2006.

[10] MSC.ADAMS/Rail: *A Model of ERRI Coach Wagon for Programme System Verification*.

[11] POLACH, O.: *Rail Vehicles Analysis, Transport Means - Computational Methods*, Textbook, University of Zilina, ISBN 80-8070-476-7, EDIS-Publishing house of University of Zilina, 2005.

[12] prENV 12299: 2006 *Bahanwendungen - Fahrkomfort für Fahrgäste - Messung und Auswertung*, 2006.

Jaromir Siroky \*

## SYSTEMATIC TIME TABLES – MODELLING OF TRAINS' PATHS BY USING GENETIC ALGORITHMS

*One of construction possibilities of a time table is the implementation of systematic timetabling. In systematic timetabling, the trains' paths are ordered regularly (thus systematically). In cargo transport there exist a range of possibilities of using an "integrated tact timetable", which ensures time and space sequences among individual services, forwarders or other kinds of transport. A net-system of service is used in intermodal transport trains, which ensures a net-wide service of each intermodal terminal in the network. The Hub and Spoke system (H&S) is used the most. The intermodal train model of route location in a chosen network is presented in this article. The methods of genetic algorithm were used for finding the result. The modelling of trains' paths lies in the minimization of intermodal unit transshipment times in intermodal transport ranges.*

### 1. Introduction

A prerequisite for effective functioning of the intermodal system in Europe is a system of shuttle or multiple-section trains regularly operating among intermodal terminals or ports oriented on technologies such as Night Jump (Nachtdprung in German) or Just in Time (with guaranteed term of delivery), as described by Lindner [19] and Panda [22].

An important part of an intermodal train's travelling time is the reloading time in node terminals. That is why routes of those trains must be coordinated on a track and in a terminal. That is also a dominant theme of this paper. Emphasis on a systematic approach is the key to the solution. This solution will use findings which are described in Caprara [3], Nielsen [20], Sevele [23] or Schmitt [24]. Results of our paper will contribute to better time and space sequence of intermodal trains in node terminals. Our approach will increase the quality of railroad cargo transport.

### 2. Systematic time tables

Systematic timetabling is one of the possibilities for a timetable construction. Its principle is in a periodically repeated structure of passenger and goods trains so that during the day the same groups of trains are repeated. According to distance among those groups we have a lag timetable or pulse timetable.

In railroad transport we have a household word – lag timetable. Its characteristic is a constant time period among trains. Therefore, we can find one-hour, two-hour, three-hour or eventually four-hour pulses, as described by Bar [1] and Ferchland [7].

On a higher quality level there exists an integrated lag timetable (further only ILT). It systematically coordinates lag timetables among more train paths or other means of transport. More basic information about ILT can be found in Diermeier [6].

Bar [1] and Hesse [12] suggest the most important requirements for ILT:

- Offer of lag transport during every day of the week,
- Offering each train path in a basic pulse (passenger trains one or two hours, intermodal trains – 4, 6, 12 or 24 hours),
- Ensuring train services for passengers from 5am to 10pm, combined with intermodal transport in continuous operation,
- Ensure good connection in node stations among systematic trains and other types of trains,
- Increase standard of quality for passengers and customers in cargo transport,
- Ensure maximum accuracy of trains (following the time table).

Another important aspect of lag timetabling is axis of symmetry. It is an instant of time when trains on the same train route are crossing (on the single track line) or meeting (on double track line). Hesse [12] found that an important requirement for ILT is the same symmetry time for all train routes. If we observe that principle it leads to a mirrored timetable. So that for each train in direction A-B we have a train in direction B-A with the same lag time, similar reloading time and block speed. In standard practice the so-called zero symmetry is often used. It means that one symmetry time is right at the beginning of an hour. For example, if one train arrives to the station in the 54<sup>th</sup> minute (60 – 6), then the train on the same route in the opposite direction will arrive in 6<sup>th</sup> minute (60 + 6).

\* Jaromir Siroky

Department of Transport Technology and Control, Jan Perner Transport Faculty, University of Pardubice, Czech Republic,  
E-mail: jaromir.siroky@upce.cz

### 3. Intermodal trains

Intermodal trains are taken as a system of fast train connections of intermodal transport (hereinafter as IMT) which ensures connection among individual IMT terminals in desired quality and sufficient volume of transported goods. Systems of through trains and mixed trains are used for the train connection among IMT terminals. From the railway carrier's point of view the whole cargo (transport unit) is transported either as an individual set of coaches or as a group of sets of coaches or as the shuttle train. The biggest share of IMT cargos is transported in the shuttle trains which all belong to the "Nex" train category.

Heinrici [11] found that the systems of train connections of IMT transport units can be operated on an individual line or on a specified line network. In the former case we speak of so-called "line system" and in the latter case we speak of the so-called "network system".

The network system of train connections is characterized as a network service of individual terminals on a specified traffic network. This means that there is a gap in the service of individual IMT terminals using line systems which are included in the traffic network. A system of shuttle trains connecting the individual IMT terminals is usually used in the network system. This network system is in the IMT area represented by the "Hub-and-Spoke" system, as described by Novak [21].

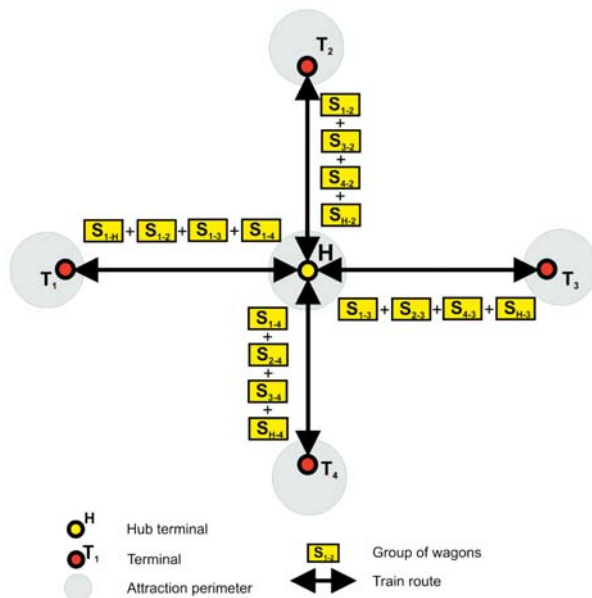

Fig. 1 Logistic technology „Hub-and-Spoke“

The "Hub-and-Spoke" technology can be combined with the line principle using the technology of multiple-section trains. The schematic representation of this technology is in Fig. 1. Novak [21] and Vrenken [26] found that the network structure based on

this technology is used mainly abroad. For example, in Germany (IMT operator Kombiverkehr) this system is represented as the "goods IC-concept". It is a very similar system to the one used by passenger trains IC, ICE and EC categories, as described by Heinrici [11].

A practical application of this technology has been found not only abroad but also in the Czech Republic. Especially in transportation among seaports (Rotterdam, Bremerhaven, Hamburg) and some inland terminals (Praha-Uhrineves, Melnik, Lovosice) that have the position of node terminals. In these lines the freight traffic volumes are high and the trains are usually set out twice per day (24 hours). In other sequential directions (other terminals in the CR or adjacent countries) the freight traffic volumes are much lower and the train set-out frequency is much lower (2 to 5 trains per week).

### 4. Train routes model for intermodal trains

The task of any transport problem solved by a mathematic model is finding its attributes, analysing all its states and verifying its scheduled parameters. This is subjected to right definition and dimensioning of system items, efficient regulation and organization of the system.

#### 4.1 General solution

In the node terminal two groups of shipments are assembled for one train. Cerna [4] and Janacek [13] suggest that in the first group are shipments which enter the system in that node. The second group are shipments which came into that node by train. If there is a node  $u$  in time  $t_{ij}$  (arrival time of train  $j$  on line  $i$ ), the shipment will be brought by train  $s_{ij}$  on train path  $L_{ij}$ , will be reloaded for time  $t'_r$  (time of reload from line  $i$  to lane  $r$ ) to position on train path  $L_r$  and will wait for the nearest train  $s_{rg}$  of that train path with the depart at time  $t_{rg}$  (departure time of train  $g$  on line  $r$ ):

$$t_{rg} \geq t_{ij} + t'_r \quad [\text{min}] \quad (1)$$

Providing that the train  $s_{ij}$  departs from a starting station at time  $t_{ij}^o$  and that the travelling time to node  $u$  is  $d_{ij}^u$  then the arrival time to  $t_{ij}$  can be formularized by 2 and 3:

$$t_{ij} = t_{ij}^o + d_{ij}^u \quad [\text{min}] \quad (2)$$

and for the train  $s_{rg}$ :

$$t_{rg} = t_{rg}^o + d_{rg}^u \quad [\text{min}] \quad (3)$$

Blackout time during waiting for reload can be formularized by 4:

$$t_{cz} = t_{rg}^o - t_{ij}^o + d_{rg}^u - d_{ij}^u - t'_r \quad [\text{min}] \quad (4)$$

If we are unable to influence the last three timing logic elements that means that the travelling times of each train are  $d_{ij}^u$  and  $d_{rg}^u$  and reloading time is  $t'$ . Then we can lower the blackout time by increasing the value of  $t_{ij}^o$  to:

$$t_{ij}^{ox} = t_{ij}^o + x_{ij} \quad [\text{min}] \quad (5)$$

or by lowering  $t_{rg}^o$  value to:

$$t_{rg}^{ox} = t_{rg}^o + x_{rg}; (x_{rg} < 0) \quad [\text{min}] \quad (6)$$

Now we can extend the formula (1) to:

$$t_{rg}^o + x_{rg} + d_{rg}^u - t_{ij}^o - x_{ij} - d_{ij}^u - t'_r \geq 0 \quad (7)$$

Besides the boundary conditions like (7) there is also another one which ensures time locations of trains  $s_{ij}$ . It may vary in fixed bounds  $(a_{ij}, b_{ij})$ :

$$a_{ij} \leq t_{ij} + x_{ij} \leq b_{ij} \quad (8)$$

Similarly for trains  $s_{rg}$ :

$$a_{rg} \leq t_{rg} + x_{rg} \leq b_{rg} \quad (9)$$

Routes  $L_i$  and  $L_r$  pass through the node  $u$  and two lines of those routes  $s_{ij}$  and  $s_{rg}$  are coordinated if there exist two numbers  $x_{ij}$  and  $x_{rg}$ , which fulfil conditions (8) and (9). So we can make a directed graph  $G = (S, H)$ , where  $(s_{ij}, s_{rg}) \in H$  if node  $u$  exists we are able to coordinate those lines (S - set of routes, H - coordinated graph of transport network). The edges determine  $h \in H$  which pairs of nodes can be coordinated but not all of the pairs from the set  $H$  can be coordinated simultaneously by a different value of  $x_{ij}$ . Therefore, a coordinated subgraph  $G' = (S, H')$  must be found where for all  $i = 1, \dots, n, j = 1, \dots, m_i$  exist values  $x_{ij}$  fulfilling the condition (7).

For the coordinated subgraph  $G'$  there exist usually more possibilities for the  $x_{ij}$  value, which comply with each pair of nodes  $(x_{ij}, x_{rg}) \in H'$  conditions (7) and (8). The selection of final value will depend on the consignment volume  $f_r$ , which will be reloaded in a node from  $L_i$  to  $L_r$ . Here we establish a term optimal solution for coordinated pairs of trains. It is determined by the subgraph  $G'$ :

$$X = \{x_{ij}\}; \quad i = 1, \dots, n; \quad j = 1, \dots, m_i \quad (10)$$

for  $i, j$  which comply with condition (8), for all  $(x_{ij}, x_{rg}) \in H'$  and condition (7) and which minimize the value of the objective function  $\bar{u}$ :

$$\bar{u} = \sum_{(s_i, s_r) \in H'} f_r (t_{rg}^o + x_{rg} + d_{rg}^u - t_{ij}^o - x_{ij} - d_{ij}^u - t'_r) \quad (11)$$

If we expect that the values  $t^o, d^u, t'$  are constant according to the optimization task the value of objective function  $\bar{u}$  is minimized after fulfilling above mentioned conditions:

$$\bar{u} = \sum_{(s_i, s_r) \in H'} f_r (x_{rg} - x_{ij}) \quad (12)$$

The resultant form of objective function depends on subtraction of values  $x_{ij}$  and  $x_{rg}$  which are additional times to arrival of a train on a train route  $t_{ij}$  or departure of a train on a train route  $t_{rg}$ . So if we want to set up the objective function for the train route model we have to come out from the formula (12) as described by Caprara [3] and Cerna [4].

#### 4.2 Formulation of a mathematical model

Railroad timetable set up is an intensive and long process. The reason is in a limited use of a computer application. It is mainly an interactive process between human experiences and automated generation of timetable tools. Kryze [18] and Nielsen [20] suggest that the whole travelling time for a consignment in intermodal transport contains these components:

- Travelling times between terminals,
- Time spent at stops on the train route,
- Waiting time (result of insufficient capacity of operation equipment),
- Synchronization time (time needed to reload consignments between two trains).

Shortening of first three times (travelling time, time spend and waiting time) is subjected to investments (of infrastructure). On the contrary, synchronization time is determined by timetable so that we are able to shorten the synchronization time only by change of organizational set-up (non-investment character). Therefore it would be better to work on optimization leading to minimization of synchronization time, as described by Dirmeier [6].

In railroad cargo transport there exist two types of synchronization:

1. Waiting of train due to unloading of goods.  
During this first type of synchronization there is an extended travelling time for goods due to unloading, and therefore there is no advantage from synchronized times.
2. Waiting of goods for connecting train  
In the second form is extended travelling time of goods which needs synchronization.

Reloading process (formation of synchronization time principle) of transport units between two trains is in Fig. 2. From that figure it follows that the waiting time has several significant spells. Those spells are due to shipping and traffic reasons. The most important part is synchronization time which depends on a minimal reloading time. Waiting time is a result of insufficient capacity of railroad infrastructure or insufficient locomotives. This time may not apply to each train. The size of that time is variable for different groups of trains. On the other hand, stopping time and time for dispatch of a train must be kept to a minimum for each train. In Fig. 2, we can see a striking difference between the waiting time of "not-reloaded" consignments in the first or second train and the waiting of reloaded consignments between those trains. That can be applied also for more than two trains in a station.

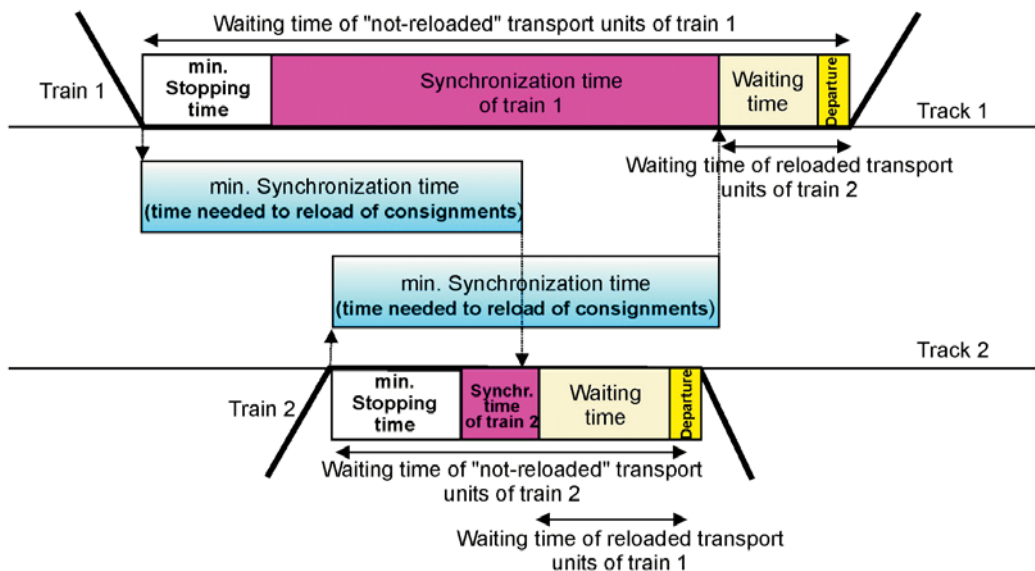

Fig. 2 Consignment reloading process

Speaking of transformation into a mathematic model the authors found two different approaches: Krista [16, 17] formulated this problem as a linear programming (for small transport networks) and solves it by simplex algorithm, Kolonko [15] solved it via genetic algorithms (for large transport networks). The linear programming calculation is very slow – it takes several hours. In case of additional conditions, the time of calculation increases. That’s why author used the genetic algorithm, which is useable for large transport networks.

This method is in a couple of aspects different from the “classic” optimization methods. Goldberg [9] found that it uses a random sample and that is why that method is non-deterministic. This means it can give us a different result for each optimization. During the optimization this method holds “population of candidates for best bet”. Only one member of that population is the best bet; the others are sample points where the best bet can be found later. That helps avoiding local optimums. Inspired by natural evolution this method makes periodically random mutations of one or more members from “population of candidates for best bet”. That process gives us new candidates. Best members of the population survive and the weak ones are eliminated. The disadvantage of that method is that we cannot recognize that the solution is optimal; therefore we don’t know a fixed rule for the end of optimization, as described by Debels [5].

Both methods have some common features:

1. The objective function is defined according to optimization criterions. It is derived from the requirement for “as short as possible” travelling time at all stages (minimal network travelling time). Because the only one variable in this value is the waiting time for connecting intermodal train in a terminal; the value can be limited to the sum of waiting times in all termi-

nals. For ensuring favourable sequences for each consignment their volumes must be taken into account because the whole travelling time is affected by volumes of reloaded consignments. The objective function is then defined as a minimum from the sum of products of synchronization time for reloading of consignments to a connecting train  $T_i$  synch and volume of reloaded consignments  $f_i$ .

$$\min \bar{u} = \min_{\{T_{synch}\}_i=1}^n \sum T_{i synch} * f_i \tag{12}$$

2. Besides travelling time, stay in terminal or reloading time models can also take into account other constraint condition like impossible occupation of a single line stage by two opposite directed trains or operating intervals.

Within common features there exist some important differences:

1. The solution via a simplex method needs a objective function and constraint conditions in a linear form but the basic problem isn’t linear. A character of lag timetable means that reloading linkage (eventually constraint conditions) may not be set up between two train routes during one period and leads to the use of the nonlinear function which returns a division reminder after integer division. Jentsch [18] found that linearization calls for an integer parameter (pulse multiplier)  $t_m$  and pulse interval  $T$  which enable pulse movement  $T_p$ . Then we have:

$$T_p = t_m * T \tag{13}$$

Such multipliers take the value from  $-10$  to  $+10$ . For each reloading terminal (constraint condition) a self pulse multiplier must be set up which is an integer parameter.

2. The simplex algorithm finds a definite optimal solution. On the contrary, a genetic algorithm finds a different solution for each calculation. That's why a genetic algorithm must be used a number of times (the more calculations the higher possibility to find the optimal solution). In the next step we analyze the best values from the genetic algorithm according to other criterions because all the terms of a real system cannot be added into the objective function. Here we can find that the best value from the genetic algorithm will be unsuitable for a real system and the most suitable will be a slightly worse value.

If we want to solve the train route problem we have to define model inputs (sort and range of values). We used the following input parameters:

- Railroad network - graph (vertices and edges) of a real railroad network; vertices are intermodal terminals, edges are tracks (Fig. 3),
- Travelling times between vertices,
- Train routes - present proposed routes of each train according to a train operation technology,
- Stopping time - minimal stopping time of a train in node,
- Sort of pulse - each route has a self pulse between 6 and 24 hours,
- Reloading time - time needed for reload of transport units among trains,
- Terminal outputs - volume of units reloaded in each node.

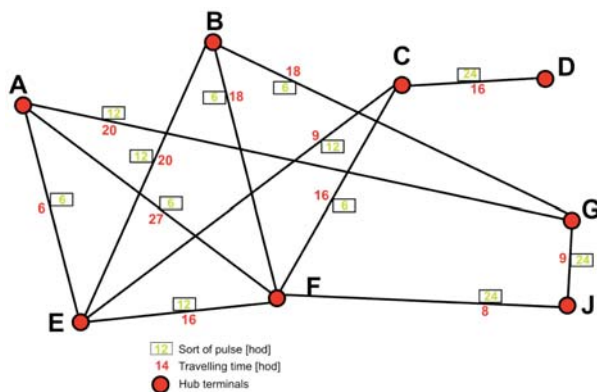

Fig. 3 Cut of Railroad network

For a theoretic model proposal a network from Fig. 3 was chosen. Sixteen nodes (intermodal terminals) and 51 reloading links were added. Distances, travelling times between nodes and pulses were proposed. The pulses are 6, 12 or 24 hours. Those values come up to real pulses for intermodal transports. Reloading times were also valued (from 6 to 10 hours). This time is enough for unloading and loading of transport units. In Fig. 3 there are also ratings of each reloading link (importance of each node). This quantity is stipulated as a link rating among each route. The value of rating is a tenth of reloaded transport units in TEU (Twenty-foot Equivalent Unit). It means that if we reload 10 TEU, the rating value is 1.

Terminal	Relation		Reloading [hod]	Rating value
	from	into		
E	A	H	6	5
	C	H	6	5
	B	H	6	5
	F	H	6	2
	C	I	6	4
	B	I	6	4
	A	I	6	4
	A	F	6	1
H	E	M	7	2
	E	I	7	1
M	H	N	8	4
I	H	F	7	5
	M	F	7	5
	E	N	7	4
	H	N	7	5
N	K	M	10	2
	M	F	10	2
	K	I	9	3
	M	P	9	4
	I	P	9	5

Fig. 4 Reloading times and reloading link's ratings - example

A very important advantage of this model is its variability. This is important especially during individual computations and can without any problems react to some input changes. This offers us the possibility to acquire more variable solutions, as described by Bienstock [2].

### 4.3 The solution results

The input data of the model were transformed using the Premium Solver Platform Version 7.0 software, Frontline Systems for Microsoft Excel 2007. Based on this product which uses the method of genetic algorithms, the model solution was run in Microsoft Excel 2007. For the needs of finding the optimal solution this computation was run 200 times. The genetic algorithm finds solutions that cannot be immediately classified as optimal ones, as described by Debels [5] and Goldberg [9]. Gondro [8] suggests that searching for the solution is random and there are usually different results in each computation. The optimization was also carried out several times (the more times the more probability of finding the optimal solution). It also seems to be appropriate to choose a few best results and evaluate them following other criteria. Because we cannot cover all the inputs existing in the real world in our objective function it is possible that the solution with its minimal value can be unsuitable in real life and, on the contrary, the best usable solution can be a solution with a slightly worse value of the objective function. Schmitt [24] and Tuzar [25] found that the finding of several suboptimal solutions can therefore be successfully used.

The solution of this model can be interpreted either in a table or in a graphic form. The results in a graphic form are expressed as a schematic representation of computed results of departures and arrivals of the trains into nodes in a network graph where the vertices are different nodes marked A to P and the edges represent individual train connections. Each node was drawn in all the relevant connections with direction and time positions of all departures and arrivals. These time positions are in hours. A value is

attached to individual tracks shown by the number within each small frame. These values say what pulse was used on that track. A section of this graph can be seen in Fig. 5.

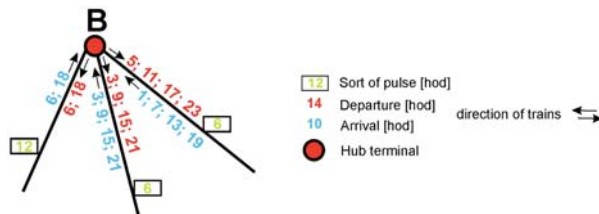

Fig. 5 Cut of graphic expression of final model solution

Results of 20 best solutions (10 % of the total count of found solutions) are shown in Fig. 6. All these solutions have the value of the objective function (sum of product of waiting times during reload and weight of reloading links representing amount of transhipped transport units) from 110 to 195. From the table it is clear that if we choose a simple sum of synchronization times the

Standings	$\Sigma T_{sync}$	$\Sigma T_{sync}^*$ Raiting value	Standings	$\Sigma T_{sync}$	$\Sigma T_{sync}^*$ Raiting value
1.	39	110	11.	59	159
2.	33	115	12.	52	162
3.	37	116	13.	53	163
4.	38	120	14.	64	168
5.	29	125	15.	71	175
6.	41	128	16.	70	184
7.	51	132	17.	67	185
8.	48	136	18.	66	189
9.	53	141	19.	78	191
10.	60	158	20.	72	195

Fig. 6 Resultant value of objective function for 20 best results

best solution will be no. 5. On the contrary the solution no. 1 – the best one according to the objective function – will be in 5<sup>th</sup> spot. It is necessary to say that the weights of the transhipped transport units that significantly influence the results are only theoretically estimated. Therefore it is valid to investigate also other solutions.

It has to be said that this designed theoretical model is directed to the phase of the preparation of possible timetables of IMT trains. Therefore, the computations are based on a premise that the timetables are adhered to and there are no reserves for elimination of possible delays.

### 5. Conclusion

The presented method of optimization of train time positions minimizes the transportation time in a given system of IMT cargo transport through minimization of time spent waiting on the sequential train in the terminal. This method can be used in other traffic systems especially in public passenger traffic, i.e. in regional railway traffic, bus traffic or in the multi-traffic systems.

The presented mathematical model cannot practically solve the set-up of pulse timetable with all constraint conditions because each constraint condition makes the solution more complicated and decreases the probability for an optimal solution. The most important constraint conditions must be incorporated into the model.

A big advantage of the proposed model is the possibility for arbitrary change of inputs. That makes the solution more variable. It is necessary to realize that the change of a route time or change of a line interval (or any other input) can result in a significant change of the total solution for time positions of other lines. Because of this, the main criterion of countries which advocate a working pulse timetable is to spend a great deal of investment in developing a timetable.

*The presented results are part of the task MSM 0021627505 "Theory of transport systems".*

### References

- [1] BAR, M.: *Fahrplan/Taktfahrplan*, Vorlesungsbegleitendes Studienmaterial, 1998, Dresden.
- [2] BIENSTOCK, D., RASKINA, O., SANIEE, I., WANG, Q.: *Combined Network Design and Multiperiod Pricing: Modeling, Solution Techniques, and Computation*, Operations Research, 2/2006, pp. 261–276, ISSN 0030-364X.
- [3] CAPRARA, A., MONACI, M., TOTH, P., GUIDA, P., L.: *A Lagrangian Heuristic Algorithm for a Real-World Train Timetabling Problem*, Proc. of the 1st International Seminar on Railway Operations Modelling and Analysis, pp. 10–29, Delft, 2005, ISBN 90-9019596-3.
- [4] CERNA, A., CERNY, J.: *Theory of management and decision in transport systems (in Czech)*, Institut Jana Pernera, o.p.s. 2004, 1. vydani, pp. 159, ISBN 80-86530-15-9.
- [5] DEBELS, D., VANHOUCHE, M.: *A Decomposition-Based Genetic Algorithm for the Resource-Constrained Project-Scheduling Problem*, Operations Research, 3/2007, pp. 457-469, ISSN 0030-364X.
- [6] DIRMEIER, W.: *Die Durchführung des Taktfahrplans in Eisenbahn-Knotenpunkten*, Thesis, Technische Hochschule Darmstadt, July 1997.

- [7] FERCHLAND, CH.: *Taktverkehr*, Proc. of ZEL '97, pp. 85-90, Zilina, 1997, ISBN 80-7135-050-8.
- [8] GONDRO C, KINGHORN B.P.: *A simple genetic algorithm for multiple sequence alignment*, Genetics and Molecular Research 6, pp. 964-982, 2007.
- [9] GOLDBERG, D. E.: *Genetic Algorithms in Search, Optimization, and Machine Learning*, Addison-Wesley Publishing Company, pp. 412, 2006.
- [10] HALLOWELL, S. F., HARKER, P. T.: *Predicting on-time performance in scheduled railroad operations: methodology and application to train scheduling*, Transportation research an International journal Part A, Vol. 4, pp.279-295, 1998.
- [11] HEINRICI, T.: *Güterzüge im InterCity-Takt*, Deutsche Verkehrs-Zeitung, Nr. 148, pp. 10, Hamburg, December 2006, ISSN 0342-166X.
- [12] HESSE, W., GUCKERT, M., HESLE, R.: *OptiTakt - A tool for developing and evaluating periodic timetables*, Proc. of 1st International Seminar on Railway Operations Modelling and Analysis, pp. 55-72, Delft, 2005, ISBN 90-9019596-3.
- [13] JANACEK, J.: *Optimization on Transport Networks (in Czech)*, Zilinská univerzita, 2006, pp. 248, ISBN 80-8070-586-0.
- [14] JENTSCH, E., GROPLER, O.: *Stochastische Zugfahrtsimulation - Zusammenhänge und Anwendungsmöglichkeiten*, Proc. Taktfahrplan und Kapazität, pp. 154-171, Utrecht 1995, ISSN 0948-8154.
- [15] KOLONKO, M., NACHTIGALL, K., VOGET, S.: *Optimierung von integralen Taktfahrplänen mit genetischen Algorithmen*, CeBit 96, Universität Hildesheim, 1996, ISSN 0941-3014.
- [16] KRISTA, M.: *Fahrplanoptimierung durch Minimierung der Synchronzeiten*, Signal+Draht 1-2, pp. 34-38, Hamburg, June 1999, ISSN 0037-4997.
- [17] KRISTA, M.: *Verfahren zur Fahrplanoptimierung dargestellt am Beispiel der Synchronzeiten*, Schriftenreihe des Instituts für Eisenbahnwesen und Verkehrssicherung, TU Braunschweig, Braunschweig 1996, ISSN 0721-7137.
- [18] KRYZE, P.: *Timetable and Transmissivity (in Czech)*, Thesis, Univerzita Pardubice, Dopravni fakulta Jana Pernera, Pardubice, September 2005.
- [19] LINDNER, H.-R., REDERN, H. W.: *Güterzüge im Taktfahrplan - Möglichkeiten und Grenzen*, Die Bundesbahn, Vol. 10, pp. 867-874, 1989.
- [20] NIELSEN. M. N., HOVE, B., CLAUSEN, J.: *Constructing periodic timetables using MIP - a case study from DSB S-train*, Intern. Journal of Operational Research, 3/2006, pp. 213-227, 2006, ISSN 1745-7653.
- [21] NOVAK, J.: *Combined Transport (in Czech)*, Institut Jana Pernera, o.p.s., pp.123-136, Pardubice August 2006, ISBN 80-86530-32-9.
- [22] PANDA, S.: *Optimal JIT safety stock and buffer inventory for minimal repair and regular preventive maintenance*, Intern. Journal of Operational Research, 4/2007, pp. 440-451, ISSN 1745-7653.
- [23] SEVELE, S., SCHNEIDER, E.: *Dispatching of train operations using genetic algorithms*, Proc. of the 1<sup>st</sup> International Seminar on Railway Operations Modelling and Analysis, pp.112-123, Delft, June 2005, ISBN 90-9019596-3.
- [24] SCHMITT, L. M.: *Theory of Genetic Algorithms II: models for genetic operators over the string-tensor representation of populations and convergence to global optima for arbitrary fitness function under scaling*, Theoretical Computer Science (310), pp. 181-231, 2004, ISSN 0304-3975.
- [25] TUZAR, A.: *Transport Theories (in Czech)*, Lecture notes, Univerzita Pardubice, Dopravni fakulta Jana Pernera, Pardubice, October 1996, ISBN 80-7194-039-9.
- [26] VRENKEN, H., MACHARIS, C., WOLTERS, P.: *Intermodal Transport in Europe*, European Intermodal Association EIA, pp. 61-92, Brussels, October 2005, ISBN 9090199136.

## MODIFIED HHT METHOD USAGE FOR VEHICLE VIBRATION ANALYSIS IN TIME DOMAIN

*The paper deals with the analysis of vehicle vibrations in the time domain. The main aim is to modify the HHT-method for the solution of mechanical systems with nonlinear members. The modification enables the computation with the constant system computational matrix. This causes that the triangulation is to be performed once only and the nonlinear members affect only the right side of the algebraic equations system. This can dramatically decrease the time consumption of the computation. We used the method modified in this way for the dynamic analysis of the model with the parameters of the specimen "ERRI - vehicle" that was kinematically excited.*

*Key words: vibration analysis, time domain, modified HHT-method*

### 1. Introduction

The analysis of mechanical systems (for example mechanical systems of vehicles) vibration is permanently very topical. The vehicle dynamic properties are determined with the help of this analysis during a new vehicle design, or a renewal of an older existing vehicle. The Eigen frequencies are characteristic of a vehicle construction. A vehicle mechanical system is excited with various types of loads in the operation and this is the reason why its individual parts oscillate. The aim of a dynamical analysis is not only to judge the influence of an excitation on the mechanical system but also, on the base of that analysis, to propose and to perform construction changes of a vehicle for the detected negative state elimination or improvement.

### 2. Vehicle vibration analysis

The aim of the vehicle vibration analysis may be the vehicle behaviour prediction before a performance of experimental tests for a vehicle approving into the operation and saving the time and financial expenses that may arise according to the tests repetition, in the case when previous tests had failed. The vibration analysis with the help of computations allows simulation of extreme loadings that evoke critical states without material losses, negative influence of a vehicle on the track, environment and so on. These computations are in practice often executed with commercial accessible programme packages. They provide results of analysis on the base of chosen vehicle parameters, track parameters and loads. The programmes utilise various methods which are their internal components. It has not become usual that a common user can affect them.

### 3. Methods for vibration analysis in the time domain

The direct numerical integration of the equation of motion is widely used for the linear systems solutions where the individual process character monitoring is important. The principal idea of a numerical integration lies in the fact that we will fulfil the equation of motion in the finite  $t_0, t_1, \dots, t_m$  moments. The distance of individual moments is  $\Delta t_k = t_{k+1} - t_k$ , where  $k = 0, 1, \dots, m-1$ , is labeled a length of integration step. Starting conditions are an inseparable part of an equation of motion. We consider the start to be the time  $t = 0$ . Then it holds:

$$q(0) = q_0 \quad \dot{q}(0) = \dot{q}_0. \quad (1)$$

We distinguish the three types of direct integration numerical methods:

- explicit,
- implicit,
- predictor - corrector.

We consider the first two types to be the fundamental ones. The Predictor - corrector method is in fact a simulation of the implicit method and is suitable for nonlinear systems solutions. The Integration method may be explicit or implicit in dependence on the moment in which it uses the equation of movement.

We compute the  $q_{t+\Delta t}, \dot{q}_{t+\Delta t}, \ddot{q}_{t+\Delta t}$  vectors from the equation of motion with the help of an explicit method on the base of the  $q, \dot{q}, \ddot{q}$  moving characteristics course shape presupposition in the interval  $\langle t, t + \Delta t \rangle$  and their knowledge in the time moment  $t$ .

\* Juraj Gerlici, Tomas Lack

Faculty of Mechanical Engineering, University of Zilina, Slovakia, E-mail: juraj.gerlici@fstroj.uniza.sk.

The implicit methods, vice versa, use the equation of motion in the time  $t + \Delta t$ . They are suitable, first of all, for the solution of the linear equation of motion with a consistent mass matrix.

The stability is a characteristic feature of numerical methods for a direct integration of an equation of motion. The stability means that the solutions must not go through limits for the arbitrary starting conditions. If this condition of an arbitrary ratio of  $\Delta t/T_n$  is fulfilled, we describe the method as unconditionally stable and if it is fulfilled for an individual critical ratio  $\Delta t/T_n$  only, we talk about a conditionally stable method. In the following text we will apply some methods that may be used for the mechanical system vibration analysis in the time domain. They are: the Difference method, the Linear acceleration method, the Wilson  $\theta$  - method, the Newmark method [3], and the HHT-method [3, 6].

### 3.1 The differential method

For the numerical integration of the equation of motion we substitute the time invariant variable for differentials. The simplest differential substitutions of the accelerations vector  $\ddot{q}$  and the velocities vector  $\dot{q}$  in the time  $t$  are:

$$\dot{q} = \frac{1}{2 \cdot \Delta t} \cdot (q_{t+\Delta t} - q_{t-\Delta t}), \quad (2)$$

$$\ddot{q} = \frac{1}{\Delta t^2} \cdot (q_{t+\Delta t} - 2 \cdot q_t + q_{t-\Delta t}), \quad (3)$$

that we apply to the equation of motion in the time  $t$

$$M \cdot \ddot{q}_t + B \cdot \dot{q}_t + K \cdot q_t = F_t. \quad (4)$$

After insertion and modification we obtain:

$$\left( \frac{1}{\Delta t^2} \cdot M + \frac{1}{2 \cdot \Delta t} \cdot B \right) \cdot q_{t+\Delta t} = F_t - \left( K - \frac{2}{\Delta t^2} \cdot M \right) \cdot q_t - \left( \frac{1}{\Delta t^2} \cdot M - \frac{1}{2 \cdot \Delta t} \cdot B \right) \cdot q_{t-\Delta t}. \quad (5)$$

The differential method is the type of an explicit method. The method has all the advantages of explicit methods, if the damping matrix is  $B = 0$  or  $B = \alpha \cdot M$ . The most effective usage is in the case of a diagonal mass matrix, id est for solutions of systems with concentrated masses. The method is only conditionally stable, in this case the length of integration step  $\Delta t$  has to meet the following demand:

$$\Delta t \leq \frac{T_n}{\pi}, \quad (6)$$

where  $T_n$  is the smallest period of the vibration. The relatively very short length of integration step is needed in order to ensure that the difference method gives the correct solution. Another disadvantage is the fact, that we need to use the special procedure in the first step.

$$q_{t-\Delta t} = q_0 - \Delta t \cdot \dot{q}_0 + \frac{\Delta t^2}{2} \cdot \ddot{q}_0 \quad (7)$$

Its advantage is the possibility to use it for a nonlinear tasks solution as well.

### 3.2 The method of linear acceleration

This method is based on the presupposition of a linear acceleration course during each of integration steps, as shown in Fig. 1.

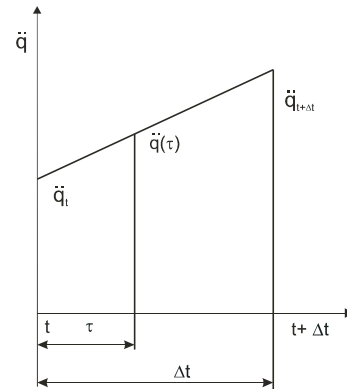

Fig. 1 An acceleration course

We label the variable that changes in the interval  $\langle 0, \Delta t \rangle$  with the mark  $\tau$ , we express the relation for acceleration with:

$$\ddot{q}(t + \tau) = \ddot{q}_t + \frac{\tau}{\Delta t} (\ddot{q}_{t+\Delta t} - \ddot{q}_t) \quad (8)$$

We obtain the relations for  $\dot{q}(t + \tau)$  and  $q(t + \tau)$  via the double integration:

$$\dot{q}(t + \tau) = \tau \cdot \ddot{q}_t + \frac{\tau^2}{2 \cdot \Delta t} (\ddot{q}_{t+\Delta t} - \ddot{q}_t) + \dot{q}_t \quad (9)$$

$$q(t + \tau) = \frac{\tau^2}{2} \cdot \ddot{q}_t + \frac{\tau^3}{6 \cdot \Delta t} (\ddot{q}_{t+\Delta t} - \ddot{q}_t) + \tau \cdot \dot{q}_t + q_t$$

In the end the integration step for  $\tau = \Delta t$  we will get:

$$\dot{q}_{t+\Delta t} = \Delta t \cdot \ddot{q}_t + \frac{\Delta t}{2} (\ddot{q}_{t+\Delta t} - \ddot{q}_t) + \dot{q}_t = \dot{q}_t + \frac{\Delta t}{2} (\ddot{q}_{t+\Delta t} + \ddot{q}_t) \quad (10)$$

$$q_{t+\Delta t} = \frac{\Delta t^2}{2} \ddot{q}_t + \frac{\Delta t^2}{6} (\ddot{q}_{t+\Delta t} - \ddot{q}_t) + \Delta t \cdot \dot{q}_t + q_t = q_t + \Delta t \cdot \dot{q}_t + \frac{\Delta t^2}{6} (\ddot{q}_{t+\Delta t} + 2 \cdot \ddot{q}_t)$$

From these relations we obtain the relations for  $\ddot{q}_{t+\Delta t}$  a  $\dot{q}_{t+\Delta t}$

$$\begin{aligned} \ddot{q}_{t+\Delta t} &= \frac{6}{\Delta t^2} (q_{t+\Delta t} - \Delta t \cdot \dot{q}_t - q_t) - 2 \cdot \ddot{q}_t \\ \dot{q}_{t+\Delta t} &= \dot{q}_t + \frac{3}{\Delta t} (q_{t+\Delta t} - \Delta t \cdot \dot{q}_t - q_t) - \Delta t \cdot \ddot{q}_t + \frac{\Delta t}{2} \ddot{q}_t = \\ &= \frac{3}{\Delta t} \cdot q_{t+\Delta t} - 2 \cdot \dot{q}_t - \frac{3}{\Delta t} \cdot q_t - \frac{\Delta t}{2} \ddot{q}_t \end{aligned} \quad (11)$$

After the insertion of the previous relations into the equation of motion in the time  $t + \Delta t$  and after modification the equation obtains the form:

$$\begin{aligned} & \left( \frac{6}{\Delta t^2} M + \frac{3}{\Delta t} B + K \right) \cdot q_{t+\Delta t} = \\ & = F_{t+\Delta t} + M \left( \frac{6}{\Delta t^2} q_t + \frac{6}{\Delta t^2} \dot{q}_t + 2\ddot{q}_t \right) + \\ & + B \left( \frac{3}{\Delta t} q_t + 2\dot{q}_t + \frac{\Delta t}{2} \ddot{q}_t \right) \end{aligned} \quad (12)$$

The method of the linear acceleration does not request any starting procedure because displacements, velocities and accelerations in the time  $t + \Delta t$  are expressed in the dependence on the same quantities in the time  $t$ .

### 3.3 The Wilson $\theta$ -method

Similar to the Newmark method, the Wilson method is implicit as well. Its original version, the method of linear acceleration, is in fact the Newmark method, where  $\delta = 1/2$  and  $\alpha = 1/6$ . The method of linear acceleration is a special case of the Wilson  $\theta$ -method, where  $\theta = 2$ . The linear change of acceleration in the interval  $\langle t, t+\theta\Delta t \rangle$  is the basic presupposition, as is shown in Fig. 2. In the arbitrary point of the interval the following holds:

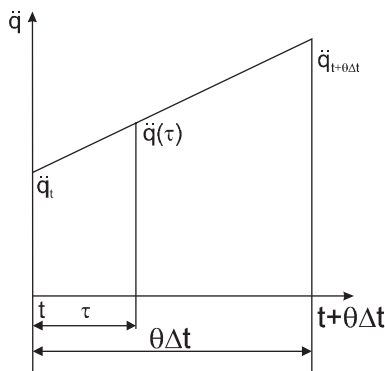

Fig. 2 An acceleration dependence on the time

$$\ddot{q}(t + \tau) = \ddot{q}_t + \frac{\tau}{\theta \cdot \Delta t} (\ddot{q}_{t+\theta\Delta t} - \ddot{q}_t) \quad (13)$$

Via a double integration we obtain the relations for  $\dot{q}(t + \tau)$  and  $q(t + \tau)$ :

$$\begin{aligned} \dot{q}(t + \tau) &= \dot{q}_t + \tau \ddot{q}_t + \frac{\tau^2}{2 \cdot \theta \cdot \Delta t} (\ddot{q}_{t+\theta\Delta t} - \ddot{q}_t) \\ q(t + \tau) &= q_t + \tau \dot{q}_t + \frac{\tau^2}{2} \ddot{q}_t + \frac{\tau^3}{6 \cdot \theta \cdot \Delta t} (\ddot{q}_{t+\theta\Delta t} - \ddot{q}_t) \end{aligned} \quad (14)$$

At the end of an integration step for  $\tau = \theta \cdot \Delta t$  we have:

$$\begin{aligned} \dot{q}_{t+\theta\Delta t} &= \dot{q}_t + \theta \cdot \Delta t \cdot \ddot{q}_t + \frac{\theta \cdot \Delta t}{2} (\ddot{q}_{t+\theta\Delta t} - \ddot{q}_t) = \\ &= \dot{q}_t + \frac{\theta \cdot \Delta t}{2} (\ddot{q}_{t+\theta\Delta t} - \ddot{q}_t) \end{aligned} \quad (15)$$

$$\begin{aligned} q_{t+\theta\Delta t} &= q_t + \theta \cdot \Delta t \cdot \dot{q}_t + \frac{\theta^2 \cdot \Delta t^2}{2} \ddot{q}_t + \frac{\theta^2 \cdot \Delta t^2}{6} (\ddot{q}_{t+\theta\Delta t} - \ddot{q}_t) = \\ &= q_t + \theta \cdot \Delta t \cdot \dot{q}_t + \frac{\theta^2 \cdot \Delta t^2}{6} (\ddot{q}_{t+\theta\Delta t} + 2 \cdot \ddot{q}_t) \end{aligned}$$

These relations lead to the expressions for  $\ddot{q}_{t+\theta\Delta t}$  a  $\dot{q}_{t+\theta\Delta t}$

$$\begin{aligned} \ddot{q}_{t+\theta\Delta t} &= \frac{6}{\theta^2 \cdot \Delta t^2} (q_{t+\theta\Delta t} - \theta \cdot \Delta t \cdot \dot{q}_t - q_t) - 2 \cdot \ddot{q}_t \\ \dot{q}_{t+\theta\Delta t} &= \dot{q}_t + \frac{3}{\theta \cdot \Delta t} (q_{t+\theta\Delta t} - \theta \cdot \Delta t \cdot \dot{q}_t - q_t) - \\ &- \theta \cdot \Delta t \cdot \ddot{q}_t + \frac{\theta \cdot \Delta t}{2} \cdot \ddot{q}_t = \frac{3}{\theta \cdot \Delta t} q_{t+\theta\Delta t} - 2 \cdot \dot{q}_t - \\ &- \frac{3}{\theta \cdot \Delta t} q_t - \frac{\theta \cdot \Delta t}{2} \cdot \ddot{q}_t \end{aligned} \quad (16)$$

We insert the previous relations into the equation of motion in the time  $\tau = \theta \cdot \Delta t$  and after the modification the equation gets the form:

$$\begin{aligned} & \left( \frac{6}{\theta^2 \cdot \Delta t^2} M + \frac{3}{\theta \cdot \Delta t} B + K \right) \cdot q_{t+\theta\Delta t} = F_{t+\theta\Delta t} + \\ & + M \left( \frac{6}{\theta^2 \cdot \Delta t^2} \cdot q_t + \frac{6}{\theta \cdot \Delta t} \cdot \dot{q}_t + 2 \cdot \ddot{q}_t \right) + \\ & + B \left( \frac{3}{\theta \cdot \Delta t} \cdot q_t + 2 \cdot \dot{q}_t + \frac{\theta \cdot \Delta t}{2} \cdot \ddot{q}_t \right) \end{aligned} \quad (17)$$

The stability and the accuracy of the method depends on the coefficient  $\theta$  choice. For the method stability it is necessary to be  $\theta \geq 1.37$ .

### 3.4 The Newmark method

This method is an implicit method. It comes out from the method of the average constant acceleration. The principal relations of the Newmark method give the relationship between the displacement, the velocity and the acceleration in the  $t$  and  $t + \Delta t$ . They are:

$$\dot{q}_{t+\Delta t} = \dot{q}_t + \Delta t \cdot [\delta \cdot \ddot{q}_{t+\Delta t} + (1 - \delta) \ddot{q}_t] \quad (18)$$

$$q_{t+\Delta t} = q_t + \Delta t \cdot \dot{q}_t + \left[ \alpha \cdot \ddot{q}_{t+\Delta t} + \left( \frac{1}{2} - \alpha \right) \ddot{q}_t \right] \cdot \Delta t^2 \quad (19)$$

From the previous relations we obtain the expressions for  $\ddot{q}_{t+\Delta t}$  and  $\dot{q}_{t+\Delta t}$

$$\ddot{q}_{t+\Delta t} = \frac{1}{\alpha \cdot \Delta t^2} (q_{t+\Delta t} - \Delta t \cdot \dot{q}_t - q_t) - \left( \frac{1}{2 \cdot \alpha} - 1 \right) \ddot{q}_t \quad (20)$$

$$\begin{aligned} \dot{q}_{t+\Delta t} &= \frac{\delta}{\alpha \cdot \Delta t} q_{t+\Delta t} - \left( \frac{\delta}{\beta} - 1 \right) \dot{q}_t - \frac{\delta}{\alpha \cdot \Delta t} q_t - \\ &- \Delta t \left( \frac{\delta}{2 \cdot \alpha} - 1 \right) \ddot{q}_t \end{aligned} \quad (21)$$

Inserting the previous relations into the equation of motion in the time  $t + \Delta t$  and after the modification, the equation has the form:

$$\begin{aligned} & \left( \frac{1}{\alpha \cdot \Delta t^2} \cdot M + \frac{\delta}{\alpha \cdot \Delta t} \cdot B + K \right) q_{t+\Delta t} = F_{t+\Delta t} + \\ & + B \left[ \frac{\delta}{\alpha \cdot \Delta t} q_t + \left( \frac{\delta}{\alpha} - 1 \right) \dot{q}_t + \Delta t \cdot \left( \frac{\delta}{2 \cdot \alpha} - 1 \right) \ddot{q}_t \right] + \\ & + M \left[ \frac{1}{\alpha \cdot \Delta t^2} q_t + \frac{1}{\alpha \cdot \Delta t} \dot{q}_t + \left( \frac{1}{2 \cdot \alpha} - 1 \right) \ddot{q}_t \right] \end{aligned} \quad (22)$$

where:

$$\delta = \frac{1}{2}, \quad \alpha = \frac{1}{4}. \quad (23)$$

### 3.5 HHT method

The HHT method [6] comes directly out from the Newmark method, where we create for  $\ddot{q}_{n+1}$  and  $\dot{q}_{n+1}$  the relations of:

$$\ddot{q}_{n+1} = a_0(q_{n+1} - q_n) - a_2 \cdot \dot{q}_n - a_3 \cdot q_n \quad (24)$$

$$\dot{q}_{n+1} = a_1(q_{n+1} - q_n) - a_4 \cdot \dot{q}_n - a_5 \cdot \ddot{q}_n. \quad (25)$$

The principal equation is

$$\begin{aligned} & M\ddot{q}_{n+1} + (1 - \alpha_f)C\dot{q}_{n+1} + \alpha_f C\dot{q}_n + \\ & + (1 - \alpha_f)Kq_{n+1} + \alpha_f Kq_n = F(\tilde{t}_{n+1}) \end{aligned} \quad (26)$$

where

$$\tilde{t}_{n+1} = t_n + (1 - \alpha_f)\Delta t$$

We put the relations (24) and (25) into the (26) and we get:

$$\begin{aligned} & [a_0 \cdot M + a_1 \cdot B + (1 - \alpha_f) \cdot K] \cdot q_{n+1} = F_{n+1}^A - \\ & - \alpha_f \cdot K \cdot q_n + M \cdot [a_0 \cdot q_n + a_2 \cdot \dot{q}_n + a_3 \cdot \ddot{q}_n] + \\ & + B \cdot [a_1 \cdot q_n + a_4 \cdot \dot{q}_n + a_5 \cdot \ddot{q}_n] \end{aligned} \quad (27)$$

where

$F_{n+1}^A = (1 - \alpha_f) \cdot F_{n+1} + \alpha_f \cdot F_n$  is an applied load

$$\begin{aligned} a_0 &= \frac{1 - \alpha_m}{\alpha \cdot \Delta t^2} \quad a_2 = \frac{1 - \alpha_m}{\alpha \cdot \Delta t} \quad a_3 = \frac{(1 - \alpha_f) \cdot \delta}{\alpha} - 1 \\ a_1 &= \frac{(1 - \alpha_f) \cdot \delta}{\alpha \cdot \Delta t} \quad a_5 = \frac{1 - \alpha_m}{2 \cdot \alpha} - 1 \\ a_5 &= (1 - \alpha_f) \cdot \left( \frac{\delta}{2 \cdot \alpha} - 1 \right) \cdot \Delta t \end{aligned} \quad (28)$$

The basic setting is

$$\alpha = \frac{1}{4} \cdot (1 + \gamma)^2 \quad \delta = \frac{1}{2} + \gamma \quad \alpha_f = \gamma \quad \alpha_m = 0 \quad (29)$$

$\gamma$  - is the coefficient of an amplitude damping; it may reach

the value  $\gamma = 0 \rightarrow \frac{1}{3}$ .

It is possible to change the setting according to the conditions.

$$\delta \geq \frac{1}{2} \quad \alpha \geq \frac{1}{2} \cdot \delta \quad \delta = \frac{1}{2} - \alpha_m + \alpha_f \quad \alpha_m \leq \alpha_f \leq \frac{1}{2} \quad (30)$$

If we use these alternatives, we determine two other methods for the parameters determination. We can choose the given coefficient of an amplitude damping  $\gamma$  for four integration parameters in the following way [8].

$$\alpha = \frac{1}{4} \cdot (1 + \gamma)^2 \quad \delta = \frac{1}{2} + \gamma \quad \alpha_f = 0 \quad \alpha_m = -\gamma, \quad (31)$$

or we can use the procedure via Chung and Hulbert [3]:

$$\alpha_f = \frac{1 - \gamma}{2} \quad \alpha_m = \frac{1 - 3 \cdot \gamma}{2}. \quad (32)$$

### 4. Modified HHT for the solution of systems with nonlinear members [4]

$$\begin{aligned} & [a_0 \cdot M + a_1 \cdot B + (1 - \alpha_f) \cdot K] \cdot q_{n+1} = F_{n+1}^A - \alpha_f \cdot K \cdot \\ & \cdot q_n + F_{n+1}^{K+} + F_{n+1}^{B+} + M[a_0 \cdot q_n + a_2 \cdot \dot{q}_n + a_3 \cdot \ddot{q}_n] + \\ & + B[a_1 \cdot q_n + a_4 \cdot \dot{q}_n + a_5 \cdot \ddot{q}_n] \end{aligned} \quad (33)$$

where

$F_{n+1}^A$  is an applied loading

$$F_{n+1}^A = (1 - \alpha_f) \cdot F_{n+1} + \alpha_f \cdot F_n \quad (34)$$

$F_{n+1}^{K+}$  is the additional force of nonlinear springs

$$F_{n+1}^{K+} = F_n^{K+}(q_n) \cdot (1 + \alpha_f) - F_{n-1}^{K+}(q_{n-1}) \cdot \alpha_f \quad (35)$$

$F_{n+1}^{B+}$  is the additional force of the nonlinear dampers

$$F_{n+1}^{B+} = F_n^{B+}(\dot{q}_n) \cdot (1 - \alpha_f) + F_{n-1}^{B+}(\dot{q}_{n-1}) \cdot \alpha_f \quad (36)$$

All the computations in the time domain were performed by the HHT method which was modified for nonlinear members with the following parameters  $\gamma = 0.15$ ,  $\alpha_m = 0.15$  and  $\Delta t = 0.005$  sec. computation.

The  $F_k^{K+}$  and  $F_k^{B+}$  for a nonlinear spring and a nonlinear damper determination respectively

For a nonlinear spring the following holds:

$$K_k = T^r \cdot \begin{bmatrix} k & -k \\ -k & k \end{bmatrix} \cdot T \quad (37)$$

$$F_k^{K+} = T^r \cdot \begin{bmatrix} f(d) - k \cdot d \\ -(f(d) - k \cdot d) \end{bmatrix} \cdot T \quad (38)$$

where:

- $k$  - is the basic spring stiffness,
- $T$  - is the transformation matrix for the transformation from a local into a global coordinate system,
- $K_k$  - is the element stiffness matrix,
- $d$  - is the strain of a spring in the local coordinate system of the spring,
- $f(d)$  - is the prescribed functional dependence of an internal force and strain in a spring,
- $F_k^{K+}$  - is the additional force from a nonlinear spring.

For a nonlinear damper the following holds:

$$B_k = T^T \cdot \begin{bmatrix} b & -b \\ -b & b \end{bmatrix} \cdot T \tag{39}$$

$$F_k^{B+} = T^T \cdot \begin{bmatrix} f(v) - b \cdot v \\ -(f(v) - b \cdot v) \end{bmatrix} \cdot T \tag{40}$$

where:

- $b$  - is the basic damping constant of a damper,
- $T$  - is the transformation matrix for a transformation from a local into a global coordinate system,
- $B_k$  - is the matrix of an element damping,
- $v$  - is the mutual velocity of node points of a damper in the local coordinate system of a damper,
- $f(v)$  - is the prescribed functional dependence of an internal force in a damper and a mutual velocity of node points of a damper in the local coordinate system of a damper,
- $F_k^{B+}$  - is the additional force from a nonlinear damper.

### 5. Test of modified HHT-method

For this method validation we used the comparison of computer evaluated dependence courses of forces and velocities, or

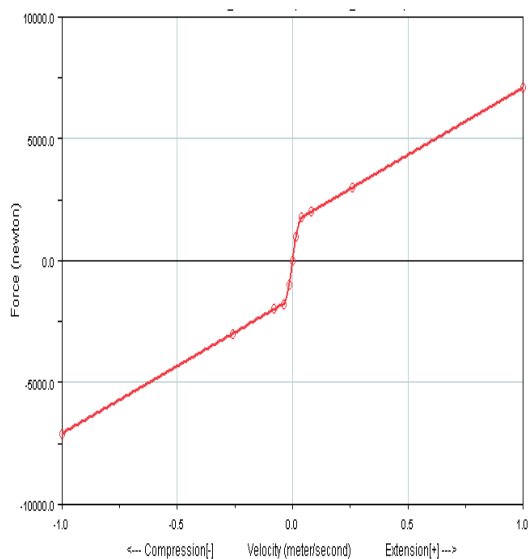

Fig. 4 A secondary suspension damper (left: given parameters, right: a comparison)

deformation “measured” in nonlinear members of computational model flexible bindings and given teoretical characteristics. These nonlinear courses may in fact describe the properties of dampers and springs. The example of a bogie model that would be equipped with flexible bindings and dampers with nonlinear characteristics is depicted in Fig. 3.

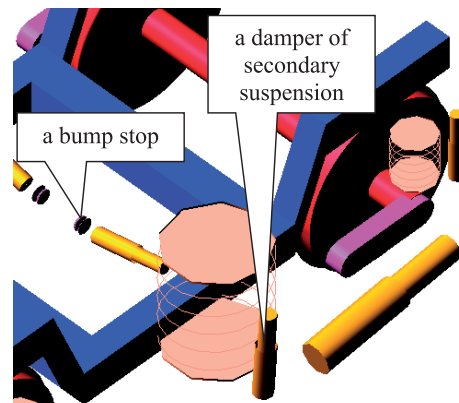
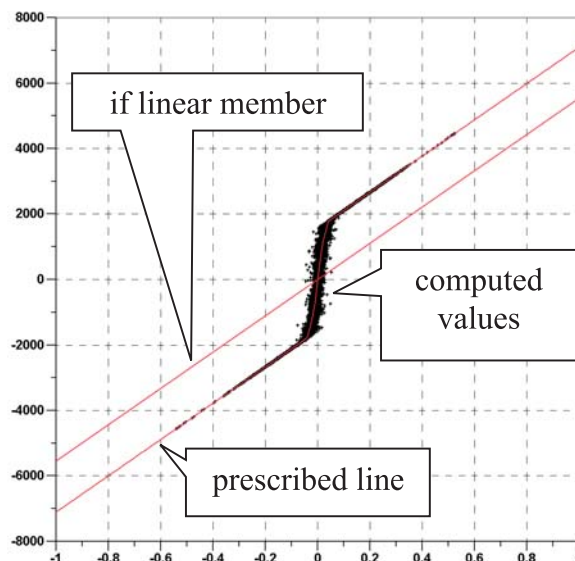

Fig. 3 An example of a bogie model (MSC.ADAMS)

The principle: the forces in nonlinear members were computed as the internal forces in the serial connected linear springs with high stiffness. The prescribed flexible member characteristics are represented by curves in the graphs. The linear dependency represents the basic stiffness, or better, the basic stiffness constant.

### 6. Conclusion

Simulation computations mainly supported by computational technique are used for the vehicle vibration analysis. The procedures and methods are used for the forced oscillation of a mechanical



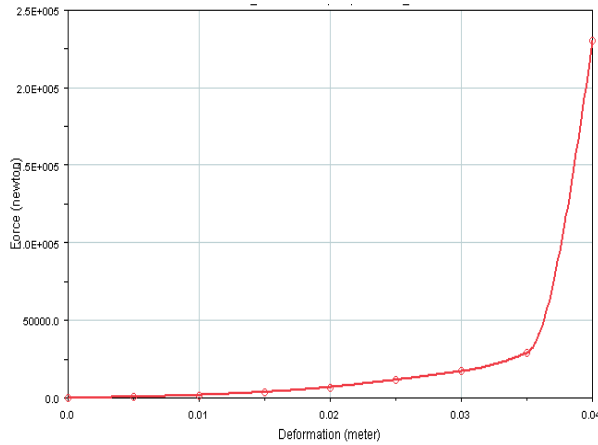

Fig. 5 A prescribed characteristics

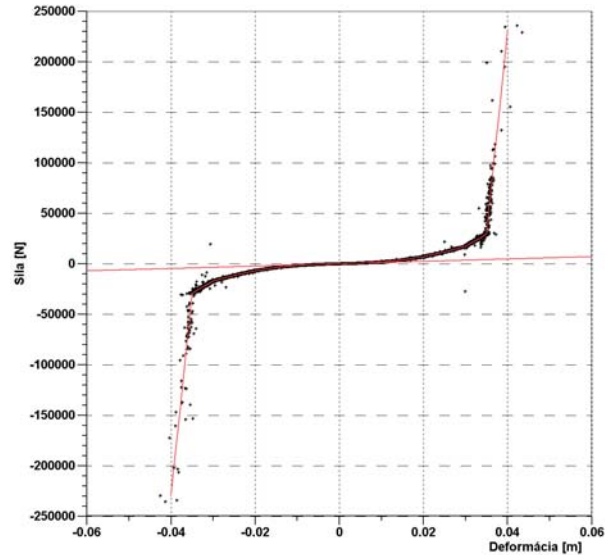

Fig. 6 An internal force versus a deformation

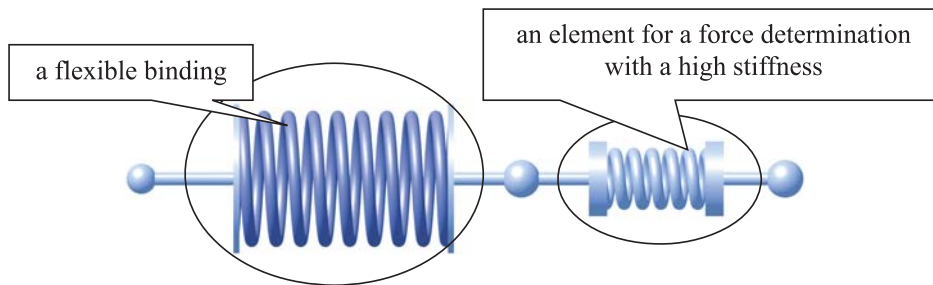

Fig. 7 Schematic depiction of "measurement" principle of internal forces in a flexible binding

system solution. The vehicle model was created for this purpose [4]. A kinematic excitation and accelerations act on the model. We can search a response from a harmonic excitation via the solution in a complex or real form, or we can analyse the vehicle vibration in the time domain. It is useful to use the HHT method [7] as a special variant of the Newmark method. The main aim was to modify the HHT-method for the solution of mechanical systems with nonlinear members. The modification enables the computation with the constant system computational matrix. This causes that the triangulation is to be performed once only and the nonlinear members affect only the right side of the algebraic equations system. This can dramatically decrease time consumption of the computation. We used the method modified in this way for the dynamical analysis of the model with the parameters of the spec-

imen "ERRI - vehicle" that was kinematically excited. The procedures were performed with the DELTA programme [5].

## 7. Acknowledgement

The work was supported by the Scientific Grant Agency of the Ministry of Education of the Slovak Republic and the Slovak Academy of Sciences in the project No. 1/3169/06 "Properties Research of Rail Vehicles in Movement with Emphasis on the Solution of a Wheel and Rail Contact at the Wheelset Rolling in the Rail via Computer Simulation" and in the project No. 1/4119/07: "Investigation of a dynamic properties of a vehicle".

## References

- [1] GERLICI, J., LACK, T.: *An Analysis of Bumpers and Springs Parameters Influence on the Ride Comfort (in Slovak)*, Dynamics of Rigid and Deformable Bodies, Proc. of V. international conference, ISBN 978-80-7044-914-1, pp. 39-48, Univerzita J. E. Purkyne v Usti nad Labem, 2007.

- [2] GERLICI, J., LACK, T.: *Methods for Vehicle Vibration Analysis in Time Domain*, Prace naukowe Politechniki Warszawskiej, Z. 63, Transport, 2007, pp. 71-81, Publishing House of the Warsaw University of Technology, ISSN 1230-9265, Warszawa, 2007.
- [3] CHUNG, J., HULBERT, G. M.: *A Time Integration Algorithm for Structural Dynamics with Improved Numerical Dissipation: The Generalized- $\alpha$  Method*, Journal of Applied Mechanics, ISSN: 0021-8936, Vol. 60, p. 371 (1993).
- [4] LACK, T.: *The Dynamic Properties Analysis of Vehicles from the Point of View of Ride Comfort (in Slovak)*, Habilitation Work, pp. 176, Faculty of Mechanical Engineering University of Zilina, 2007.
- [5] LACK, T., GERLICI, J.: *The Programme System DELTA Exploitation for Numerical Analysis Performances (in Slovak)*, Proc. of 18<sup>th</sup> International Conference "Current Problems in Rail Vehicles - PRORAIL 2007" - Part II, pp. 11-22, EDIS, ISBN 978-80-89276-07-3, Zilina, 2007.
- [6] LACK, T., GERLICI, J.: *Vehicles Dynamic Properties Analysis from the Point of View of Comfort for Passengers*, Archives of Transport, issue 1-2/2007, pp. 91-110, ISSN 8066-9546, Warszawa, 2007.
- [7] NEGRUT, D., RAMPALLI, R., SAJDAK, T.: *On the Implementation of the method in MSC.ADAMS*, p. 12, 2004, Technical support for MSC.SOFTWARE users, published on the Internet.
- [8] WOOD, W. L., BOSSAK, M., ZIENKIEWICZ, O. C.: *An Alpha Modification of Newmark Method*, International Journal of Numerical Method in Engineering, ISSN 0020-7683, vol. 15, p. 1562, 1981

Peter Faith \*

---

## PASSENGER ROAD TRANSPORT TRENDS IN THE SLOVAK REPUBLIC

*The article deals with the present trends in the passenger road transport in the Slovak Republic. It provides the characteristic of indicators of development phases of the passenger road transport trends. Existing increase of number of vehicles and individual road transport performances shall bring unfavourable impacts on environment on the one hand and on the other hand, it shall be the source of the state budget income.*

*Permanent conflict between individual road transport and mass passenger transport makes all administrative authorities to follow impacts on the life of inhabitants in agglomerations with assumed higher concentration of inhabitants. Demand for passenger cars will be permanent and any decrease in the passenger road transport cannot be assumed. Therefore, it is necessary to show a permanent interest in this sphere of problems and deal with it on the highest possible level.*

### 1. Introduction

Following the Slovak Republic accession to the European structures and gradual market economy development, markedly changes have been accomplished including different social and population impacts.

At present, passenger road transport trends in our country are necessary to be studied in light of different aspects. On the one hand, existing increase of number of vehicles and individual road transport performances brings unfavourable impacts on environment and on the other hand it represents an income to the state budget from sale of fuels, vehicles and other items related to the passenger road transport.

A separate chapter includes building necessary transport areas, namely parking and lay-by areas, final building and maintaining good conditions of all road categories.

Most intensive passenger road transport development is evident in areas with high density of population where it causes difficulties in sustainable environment, i.e. it acts mainly as an unfavourable factor.

Permanent conflict between individual road transport and mass passenger transport makes all administrative bodies to follow impacts on the life of population in agglomerations with assumed higher concentration of inhabitants. It is necessary to determine an effective co-operation rate between individual road transport and mass passenger transport which is impossible in number of cases. Different measures, however, may be taken to influence effi-

ciently modal split, particularly in the event of travels for work purposes, i. e. regularly repeated trips per day.

All present impacts on passenger road transport development which included, for example, the energy crisis at the beginning of seventies, the increase of fuel prices or cars didn't cause any markedly deceleration of development of the said mode of passenger transport. This trend may be observed not only in the developed countries where the degree of passenger road transport amounts to around 2.5 inhabitants per one passenger car but also in less developed countries with the degree of passenger road transport amounting to around 5.5 inhabitants per one passenger car.

### 2. Present passenger road transport trends in Slovakia

Issues concerning development and reach of reasonable saturation of individual transport needs of the population rank among topical issues, in particular, in relation to a living standard, the way of living and environment. Relation to a passenger car and to the passenger road transport trends in general represents an important factor. Opinions concerning passenger car have been different and reflect political and economic situation of the society.

Slovakia during its independence period has failed to reach the degree of passenger road transport of majority of European countries and it even lacks behind the Visegrad Four Countries or some Baltic Countries. At present, the degree of passenger road transport in Slovakia has amounted to about 4 inhabitants per one passenger car which in the Czech Republic has amounted to 2.4 inhabitants, in Hungary to 3.5 and in Poland to 3.1 inhabitants per one passenger car [2].

---

\* Peter Faith

Department of Road Transport, Faculty of Operation and Economic of Transport and Communications, University of Zilina, Slovakia  
E-mail: Peter.Faith@fpedas.uniza.sk

Resulting from experience the degree of passenger road transport of about 5 inhabitants per one passenger car starts to cause first problems within the society, which means the road safety, parking problems, etc. With the degree of passenger road transport of 2.5 inhabitants per one passenger car very serious problems occur in the urban traffic and the weekend peak hour traffic when car congestions are formed at entries to bigger towns.

Present passenger road transport trends in Slovakia may be characterised as gradually developing (Table 1). During the period from 1970 to 1980 number of passenger cars increased 3.4 times, from 1980 to 1990 1.6 times, from 1990 to 2000 1.5 times. Even though the comparison of present individual passenger road transport trends indicates that certain car boom level already has occurred in Slovakia it may be expected that a cyclic development with different level of increases will continue in the future.

Vehicle Number Trends in Slovakia Table 1

YEAR	Passengercars	Passenger road transport degree /inhabitans/car/	Number of passenger cars/1000 inhabit.
1965	53870	81.53	12.27
1970	158690	28.61	34.95
1975	339427	14.03	71.25
1980	535952	9.32	107.27
1985	687067	7.54	135.81
1990	875550	6.07	165.95
1995	1015794	5.28	189.24
2000	1274244	4.24	235.86
2005	1304705	4.13	242.10
2006	1333749	4.04	247.28

Source: The SR Presidency of the Traffic Police

Passenger road transport trends should be understood from two views; an external – social and an internal – an individual (a family). There is a narrow connection between exogenous and endogenous factors of the economic development. To carry out an exhausting analysis of this economic changes and decisions interaction means a very demanding task. In specification of individual passenger road transport development trends it is therefore necessary to result from existing experience and knowledge of countries which already have faced the similar problem. An assumed individual car transport development in Slovakia is presented in the alternative development scenarios by 2030.

With regard to the Slovak economy orientation to the market economy an issue concerning the social establishment differences is insignificant and purely economic issues and issues concerning the way of living are foreground.

In connection with this it is necessary to mention the basic fact that Slovakia will be one of the countries with the highest

portion of manufactured passenger cars per one inhabitant per year in the world.

This fact should also be taken in consideration in approach to the economic evaluation of individual road transport development which can be divided into several phases [1]:

- In Phase 1, leading economists considered the road transport trends together with building own manufacturing basis one of the main important factors which should speed-up economic development in the country; this period falls into the post-war economic restoration period. Phase 1 also covers the present period when after gaining an economic independence the passenger car manufacture development in Slovakia assumed a new dimension when two world automobile factories have added up the existing automobile factory;
- In Phase 2, a passenger car has been understood a mean of transport evaluated under commonly used criteria in evaluation of other public transport systems, i. e. an economic efficiency criterion of the basic mean in the light of transport sector;
- In Phase 3, an economic efficiency criterion has been transferred to the population personal consumption where a passenger car is understood a long-term consumed asset suitable for realisation of an increasing income of the population; its transportation function is secondary in number of cases;
- Finally, at present, the convergence of aspects all preceding development phases have occurred and a passenger car is on the one hand considered a mean of production for a group of people and on the other hand, a mean of transport satisfying best criteria for passenger transport.

In every development phase it is possible to accept an economic evaluation method where the amount of a gross national product (GNP) plays an important role from the social aspect. Time price depending on an income amount is decisive in the light of an individual, i.e., time saving expressed in monetary units achieved thanks to a passenger car use. The fact that the GNP amount depends to a certain level on number of passenger cars per inhabitant has already been proved in the preceding development phase analyses.

Upon gross national product increase per inhabitant in the country the number of passenger cars has increased while the time factor plays an important role and decrease of necessary GNP level per one car occurs with time in the country. It means that countries with lower GNP level are able to allocate a lower amount to passenger road transport than more developed countries with a higher GNP level. Foreign experience indicates that passenger road transport grows faster in the countries in which a higher GNP inter-year increase has been recorded than in the countries which reach a high GNP level/inhabitant in the long term and approach the saturation level of number of passenger cars per number of inhabitants. To compare the situation in the CR and Slovakia in 2005, there was 1000 EUR GNP/inhabitant sufficient for approximately 44 passenger cars/1000 inhabitants in the CR and this value corresponds to 35 passenger cars/1000 inhabitants in Slovakia. Yet more interesting is a comparison between some EU countries for 2002 presented in the following Fig. 1 [2].

Despite an unsteady SR economic development when the GNP development has recorded a higher level in comparison with other European countries it is possible to assume that the next individual passenger road transport development will be very dynamic. The preceding economic situation was rather complicated and non-

transparent to forecast the passenger road transport trends and it was impossible to consider it sustainable and make definite conclusions. We may assume that the present economic growth will further continue in the next years thus increasing the rate of passenger cars/inhabitants in passenger road transport development.

**Relation between GNP in EUR per one inhabitant and number of passenger cars per 1000 inhabitants in selected European countries (Situation in 2002)**

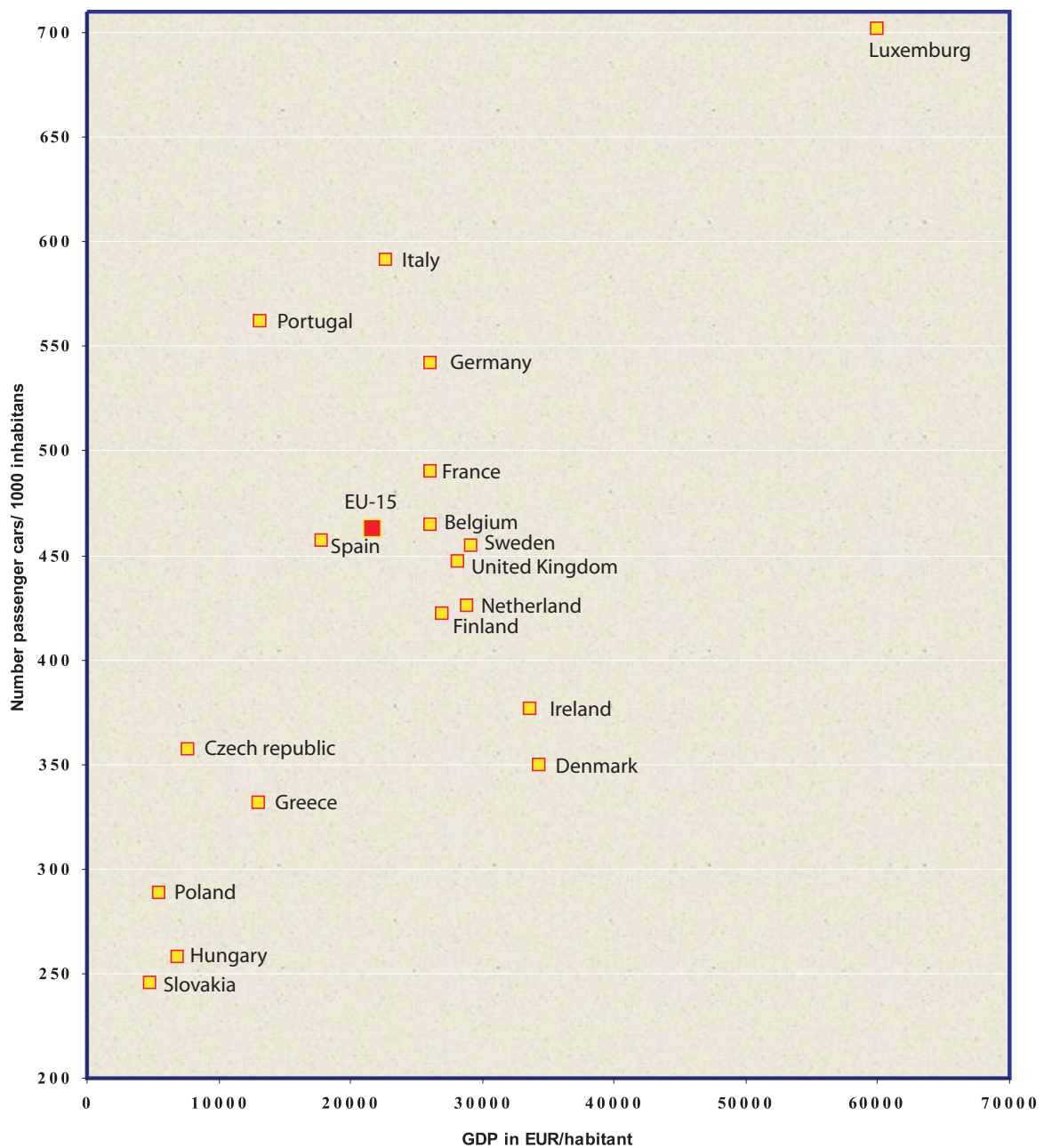

Source: The Eurostat

Fig. 1 Relation between GNP in EUR per one inhabitant and number of passenger cars per 1000 inhabitants in selected European countries

Upon this strengthening of pretensions to a passenger car Slovakia will be able to reach soon some European countries.

From economic factors studies it is possible to derive both exogenous and endogenous factor impact on the passenger road transport development. Endogenous factors include a family income,

an average wage amount, a time price, and a way of living. The living standard which may be considered a summary explication of endogenous factors has been considerably differentiated.

A principal insufficiency rests upon the fact that differentiation has failed to proceed in accordance with the rate of labour and business results. The living standard has increased only with some preferred professions, while the living standard of majority of the population has considerably decreased. The aforesaid facts have influenced the level of passenger cars in Slovakia.

There are still more frequent “expensive” foreign cars on our roads on the one hand and on the other hand families with low income try to maintain in operation older cars which frequently do not comply with requirements for vehicle technical conditions.

Resulting from this economic analysis in the light of the high - optimistic scenario it is possible to expect the amount of 420

passenger cars per 1000 inhabitants, i.e. 1.4 inhabitants per 1 passenger car in 2030 [1].

### 3. Passenger Road Transport Trends

In the past, passenger road transport trends in Slovakia were characterised by different rates of growth of number of passenger cars [3]:

- 1965 - 1970 in average by 66.7 %,
- 1971 - 1975 in average by 43.0 %,
- 1976 - 1980 in average by 28.4 %,
- 1981 - 1985 in average by 17.5 %,
- 1986 - 1990 in average by 16.2 %,
- 1991 - 1995 in average by 10.8 %,
- 1996 - 2000 in average by 13.3 %,
- 2001 - 2005 in average by 13.5 %.

As in December 31, 2006 the total number of passenger cars in operation reached 1 333 305 units and the total number of motor vehicles reached 1 710 645 units [3].

In the light of the attained passenger road transport degree of 4.05 inhabitants per 1 passenger car, i.e. 247.28 passenger cars per 1000 inhabitants, Slovakia ranks among the European countries with the lowest passenger road transport development degree.

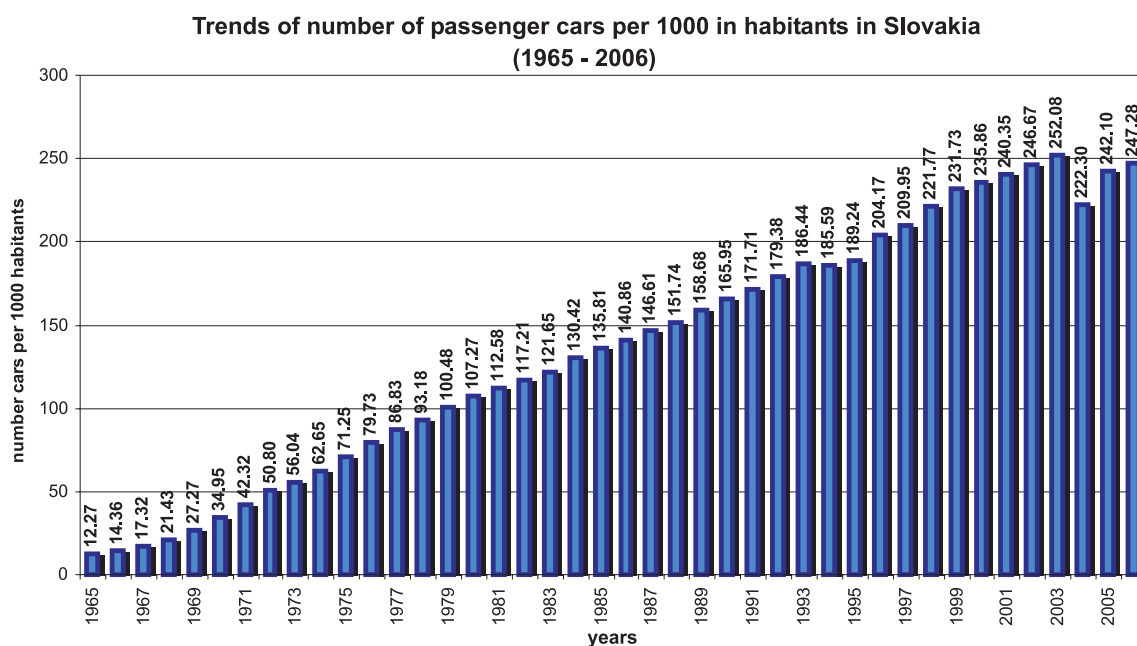

Source: The SR Presidency of the Traffic Police

Fig. 2 Trends of number of passenger car per 1000 inhabitants in Slovakia (1965-2006)

The degree of passenger road transport development in Slovakia, however, did not develop equally in all areas of the country which was caused by number of reasons being not studied thoroughly yet.

As regards the passenger car degree, some regions as the Trenčín region, the Presov and the Zilina regions reach only half of the Bratislava level. It is impossible to determine exactly causes of differences in the passenger car degree in individual SR regions. A survey and a more detail analysis should be performed. From the given Fig. 3 higher passenger car degree per inhabitants is shown in the Bratislava region, which is caused by a high degree of cars in the town where it attains 429.97 passenger cars per 1000 inhabitants [1].

Differences of passenger car degree per inhabitants according to individual regions (year 2006)

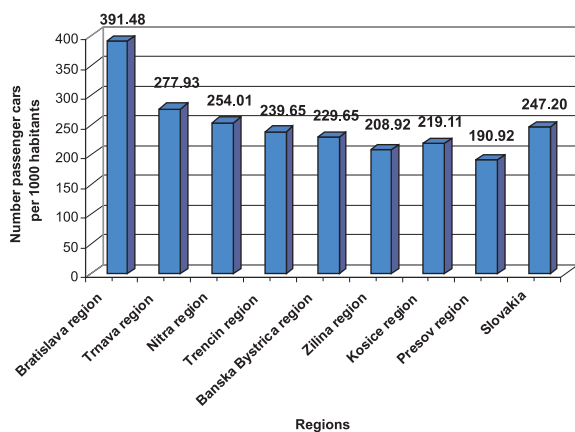

Source: The SR Presidency of the Traffic Police  
Fig. 3 Differences of passenger car degree per inhabitants according to individual regions (year 2006)

#### 4. Passenger car sales and increases

Trends of the specific passenger car increase registered by the transport police in Slovakia have been favourable. An annual average increase has represented 35 000 units of passenger cars by now. It is interesting to compare an increase of number of inhabitants with number of passenger car increase for the analysed period from 1966 to 2006. When the proportion of number of inhabitants increase to the number of passenger car increase was more than 1 by 1985, there was a turnover after 1985 when an annual increase of number of passenger cars exceeded the number of inhabitants increase (Fig. 4) [5, 4].

After 1989 principal changes occurred in the passenger car market. The supply - demand ratio turned after 1989 and all the world car makes have been gradually introduced in our market. At

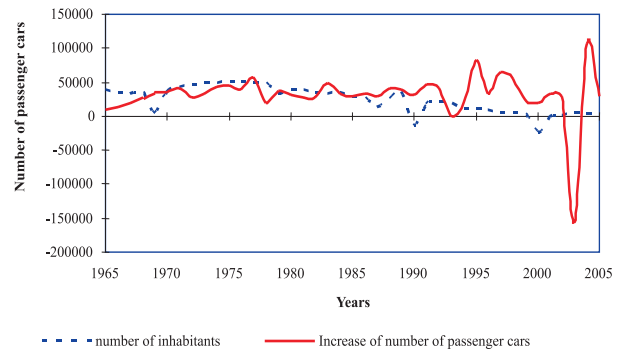

Source: The SR Presidency of the Traffic Police  
Fig. 4 Trends in increase of number of passenger cars and inhabitants

present, there are 48 passenger car makes of different types and models marketed in our market.

Older cars which were either bought in the used-car dealerships and from sellers or imported from abroad should be also calculated in the passenger car increase.

Annually, there are 57 000 new cars sold in average at our market. However, there were 74 903 cars sold in total at our market in 1996 which was caused by cancellation of import duty on passenger cars with cylinder capacity by 1400 cm<sup>3</sup>.

In 2004 an obligatory replacement of car registration plates was introduced which caused higher number of older cars being removed from the Transport Inspectorate Records and significant decrease occurred in the real increase of passenger cars.

#### 5. Passenger car sales by car makes

An annual passenger car increase (the difference between the newly registered cars and those removed from the Transport Inspectorate Records) represents around 40 000 units.

For the period from 1965 to 2006 the first position was constantly held by Skoda car whose average annual sales represented approximately 15 000 units, at present Fabia and Octavia types prevail. In recent years, Volkswagen, Renault, Peugeot, Opel and Citroen are other most frequently sold car makes. Certain shifts by car makes occurred at the passenger car market over the past two years. It can be said that the Slovak market is typically oriented at cheaper cars which must, however, meet basic usable properties, and its orientation is also aimed at car makes whose production started in Slovakia in 2006, i.e. Peugeot and Kia. While Peugeot belonged to the well sold cars also before 2006, Kia has attained very quickly an important position in the market; by 2006 number of sold Kia cars was low, some 500 units per year, after 2006 it

attained the 6th position of the best sold cars and in 2007 it sold 3743 cars which means tripled sales of cars in 2006 [5].

### 6. Passenger car lifetime

An average passenger car lifetime may be assumed for 20 – 25 years in the SR. More than 44 000 passenger cars are older than 30 years. The highest number of passenger cars is within the range of 5 – 10 years of age which represents approximately 356 000 units (Fig. 5) [3].

At present, an average age of the passenger car fleet is about 13 years. The above lifetime significantly exceeds values attained in the developed countries which results from two following factors:

- The relation between the total price of a new car and income of inhabitants;
- Amount of fuel price and spare part price for a passenger car.

Tax decrease of new vehicles and fuels and increase of spare part tax could lead to the decrease of an average lifetime to approx-

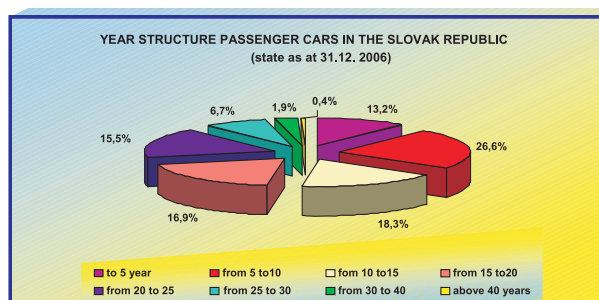

Source: The SR Presidency of the Traffic Police and own calculations  
 Fig. 5 Year structure passenger cars in the Slovak Republic (state at 31.12.2006)

imately 15 – 18 years and to the substantial increase of efficiency of operation of the entire passenger car fleet.

A long car life operation or its maintenance in the SR has been reflected in different fields, for example in:

- fuel consumption increase and their assortment preservation;
- necessity to produce, import and store spare parts for excessively/too long time (for 10 years),
- increase of material use for operation to ensure the operation – fleet capabilities,
- deterioration of unfavourable impacts of the passenger road transport on environment etc.

### 7. Conclusion

Individual passenger road transport trends in the Slovak Republic will continue to move forward and in the light of the present experience it will be neither stopped by such events as energy crisis, increase of car and fuel prices in the past, nor by the

measures taken in the tax or charge payments.

Macroeconomic indicators and the society sustainable development influence passenger road transport trends from external point of view and the way of living of inhabitants and their living standard influence it from an internal point of view. There is a narrow connection between exogenous and endogenous factors of the economic development. To perform an exhausting analysis of an interaction between the economic changes and decisions which influence passenger road transport is a very demanding task. In our conditions, this task is even more complicated for the present stage of the economic development and for the next stable development and line-up with more developed European countries.

The passenger road transport forecast should result from the present experience and knowledge of the countries attaining high degree of number of passenger cars per inhabitants.

It may be assumed that opinions concerning the passenger car ownership do not change, on the contrary, there is a permanent interest in a passenger car and its use will become an inevitable part of the everyday life of people for different purposes.

A passenger car meets a wide range of quality criteria laid on different purposes of trips. It is characterised by a high level of readiness for transport, high speed door-to-door transportation services, it is evaluated as a very comfortable means of transport and travelling by a passenger car ensures a maximum degree of privacy. In addition, many passenger car owners consider cars their hobby.

A passenger car compared with means of mass passenger transport still successfully competes in the high speed long distance transfer. A passenger car use gradually becomes a problem in urban areas with high density of population from both the environmental and time loss point of view where mass urban transport should take over a part of passengers, especially in trips for work purposes. From results of performed surveys resulted that a passenger car is used more frequently for trips to the work than means of mass passenger transport.

Assuming that the share of leisure time of inhabitants will increase it is possible to expect an increased interest in the passenger car use in trips for sport, recreational and holiday purposes.

From the point of view of the state the passenger road transport represents an effective source of income to the state budget into which flow important portions which partially return for the road infrastructure development. High quality and large capacity road infrastructure is inevitable to preserve the safe and continuous road traffic. Its level reflects the passenger road transport degree in the country

The passenger road transport from the social point of view should be also considered the factor stimulating activities in the region and creation of new work opportunities, the education level increase as well as the orientation in achieving new knowledge in modern technology.

Modal split between the individual passenger transport and the public mass transport should be influenced by quality improvement of services provided mainly by urban mass transport. The individual passenger transport may reasonably substitute the public mass transport under certain conditions.

Finally, it should be mentioned that opinions concerning passenger road transport trend dynamics and its growth limits in our country may differ. However, in general, the number of passenger cars will no doubt increase in the next few decades.

### References

- [1] Research project: *Development of the Individual Motoring in the Slovak Republic to 2020 (in Slovak)*, TRI Zilina, 1997
- [2] <http://epp.eurostat.ec.europa.eu>
- [3] *The Registration of Motor vehicles (in Slovak)*, The SR Presidency of the Traffic Police
- [4] *The Statistics Year Book (in Slovak)*, The Statistical Office of the Slovak Republic
- [5] *The Sale Survey of the Passenger Cars (in Slovak)*, The Automotive Industry Association of the Slovak Republic.

## AN ANALYSIS OF AIR FLOW AT VARIOUS SPACING OF FANS ON A PHYSICAL MODEL OF A ROAD TUNNEL

*In this article, the influence of a jet fan spacing in a longitudinal air conditioning system in a road tunnel on a physical model of the tunnel is analyzed. The analysis of air transport on a physical model with a length of 30 metres was accomplished for various combinations of the connection of 8 jet fans (parallel connection of 8 fans, combined connection of  $2 \times 4$  parallel fans, combined connection (of)  $4 \times 2$  parallel fans and serial connection of 8 fans). From the analysis of measurement on the physical model follows what a big influence the fan spacing has on the speed profile, which to a great extent influences air transport in the tunnel. Our contribution deals with the interpretation of vibration data from the point of view of vibration sources identification. These sources are searched and evaluated from the measured data using a frequency and phase spectrum.*

### 1. Introduction

Nowadays, transport in connection with the construction of transport infrastructure is moved much more often through underground tunnels, especially in mountainous regions and town agglomerations. This brings, though, a whole variety of problems with itself, which need to be solved reliably. This concerns the securing of the required volume flow rate of fresh air for ventilation at an optimum energy demand of vent system, a suitable way of venting exhaust emissions with a minimization of environmental pollution in the surrounding of the tunnel and a minimization of security risks at collisions in the tunnel especially.

A very often used way of venting the road tunnels is, especially in shorter tunnels, a longitudinal ventilation, Fig.1, [1], [4].



Fig. 1 Longitudinal ventilation with jet fans

Nowadays, based on the knowledge and consequences of fires in the tunnels in Western Europe, the increased attention is paid to venting and to the design of ventilating systems of road tunnels, which are an essential part of fire safety assurance in the tunnel. Calculations are still applied at designing ventilating systems, which are based on the theory of one-dimensional flow and on experiments on already existing road tunnels. In many cases, to analyse some problems of ventilation in laboratory conditions on physical models has shown to be very suitable [2], [3].

From the point of view of the jet fan operation safety, vibrations play an important role. Because of this, increased attention has to be paid to them. The measurements of the vibrations have to be checked at least every 6 months and in the initial operation even more often. The vibration degree in the horizontal and vertical directions has to be checked at the measuring points which were marked out during the first measurement. If the vibration values are extremely different, the reasons of their origination have to be found (e.g. dust on the fan blades). In case of a vibration increase, it is necessary to correct the balance of the fan. The increase of vibrations can cause the destruction of the fan and a guaranteed expiration of conditions. At higher vibrations it is recommended to check the fan more often than within 6 months. The vibrations during an operation should not exceed the value of 2.8 mm/s [5].

In this article, the influence of a jet fan spacing at a longitudinal ventilating system in the road tunnel on a physical model of the tunnel is analysed. This article also introduces the way of vibration measurement and the analysis of measured values [7], [8].

### 2. Physical model

The physical model was realized in the ratio 1:10 to the real road tunnel. This model is shown in Fig. 2. Its framework was created with 15 stainless tubes with a diameter of 0.8 m and a length of 2 m. The total length of the physical model was 30 m. Polystyrene was placed at the air entrance of the model to avoid turbulences in the vicinity of the air entrance. The polystyrene was placed at the air exit of the model as well.

The measured values were recorded (temperature, pressure and speed) into the data logger. The temperatures and pressure were

\* Jozef Jandacka<sup>1</sup>, Stefan Papucik<sup>1</sup>, Vladimir Dekys<sup>2</sup>, Richard Melicher<sup>2</sup>

<sup>1</sup>Department of Power Engineering, Faculty of Mechanical Engineering, University of Zilina, Slovakia

<sup>2</sup>Department of Applied Mechanics, Faculty of Mechanical Engineering, University of Zilina, Slovakia, E-mail: Jozef.Jandacka@fstroj.uniza.sk

measured 60 cm from the edge at the entrance and the exit of the model to record the steady values of air flow. The speed was measured with a propeller-type flow meter at three places, Fig. 3. The measurement place A was situated 30 cm from the model entrance, place B was 15 m from the the model entrance and place C place was 30 cm from the model exit. In each section, the speed was measured at 24 points in a horizontal section according to Fig. 3.

The analysis of air transport on the physical model was accomplished for various spacing of the 8 fans. All the fans were of the same type: Turbo 100 produced by Dospel Company. The fan diameter in the model was 100 mm, and it supplied  $160 \text{ m}^3 \cdot \text{hod}^{-1}$  of air at the operating speed of  $2500 \text{ min}^{-1}$ . The following variations of the fan positions were measured:

- Parallel connection of 8 fans, connected next to each other, at a distance of 1.5 m from the model entrance (Fig. 4).
- Combined connection of  $2 \times 4$  parallel fans, at a distance of 1.5 m from the model entrance and model exit (Fig. 5).
- Combined connection of  $4 \times 2$  parallel fans, at a distance of 1.5 m from the model entrance and model exit (1st pair of fans) and the 2nd pair of fans at a distance of 2 m from the 1st pair (Fig. 6).
- Serial connection of 8 fans, where the 1st fan is placed 1.5 m from the model entrance and the next fans are placed 2 m from the previous fan (Fig. 7).

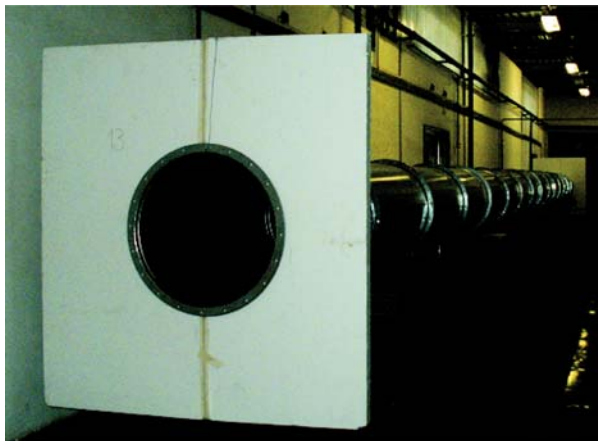

Fig. 2 The physical model of a road tunnel

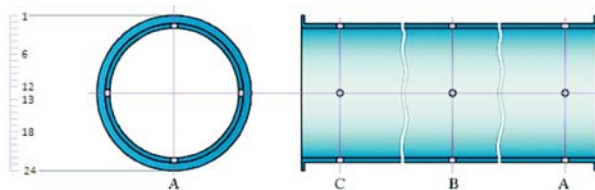

Fig. 3 The scheme of measuring points for speed measuring



Fig. 4 Parallel connection of 8 fans, variant a



Fig. 5 Combined connection of  $2 \times 4$  parallel fans, variant b



Fig. 6 Combined connection of  $4 \times 2$  parallel fans, variant c



Fig. 7 Serial connection of 8 fans, variant d

### 3. Analysis of measured results

In graphs 1 to 4 are introduced measured and evaluated speed profiles of the physical model of the road tunnel at measuring places A, B, and C in a horizontal direction (see Fig. 3). From the presented graphs it can be seen that the speed profile at place A is approximately the same at all variants of fan spacing in the road tunnel model, which implies that various fan spacing has no cardinal effect on the speed profile at the air entrance to the physical model of the tunnel. By the parallel connection of the 8 fans, graph 1, the processes of the speed profiles at the measuring places B and C are approximately the same. The reason for this can be seen in the stabilisation of air flow. In graph 2, by the connection of  $2 \times 4$  parallel fans, the speed profile measured at place B is stabilized, but the speed profile at place C has a decreasing trend in the direction of the lower part of the tunnel model. This effect can be explained by the spacing of 4 parallel fans very close to the place of measuring. The fan sucks in air through its paddle wheel, which leads to the increase of air flow speed in the upper part of the tunnel model. The air in the lower part of the tunnel model is flowing under the influence of air momentum, which is created by the jet fan. In the case of the connection of  $4 \times 2$  parallel fans, the measured speed profile at place C is steady; however, the speed profiles at place A and C change, which is again affected by the

spacing of the fan from the measuring place. The air velocity fields at a serial fan connection are introduced in graph 4, where the influence of fan spacing on the measured place can be seen.

From the measured air velocity fields were calculated average speeds in the particular places of measuring. For each variant of fan combination on the physical model and for each particular place we got the following average values of speed ( $v_{str}$ ):

Variant a) measuring place A:  $v_{str} = 1.80 \text{ ms}^{-1}$ , measuring place B:  $v_{str} = 1.43 \text{ ms}^{-1}$ , measuring place C:  $v_{str} = 1.44 \text{ ms}^{-1}$ ,  
 Variant b) measuring place A:  $v_{str} = 1.55 \text{ ms}^{-1}$ , measuring place B:  $v_{str} = 1.23 \text{ ms}^{-1}$ , measuring place C:  $v_{str} = 1.64 \text{ ms}^{-1}$ ,  
 Variant c) measuring place A:  $v_{str} = 1.42 \text{ ms}^{-1}$ , measuring place B:  $v_{str} = 1.16 \text{ ms}^{-1}$ , measuring place C:  $v_{str} = 1.10 \text{ ms}^{-1}$ ,  
 Variant d) measuring place A:  $v_{str} = 1.62 \text{ ms}^{-1}$ , measuring place B:  $v_{str} = 1.40 \text{ ms}^{-1}$ , measuring place C:  $v_{str} = 1.36 \text{ ms}^{-1}$ ,

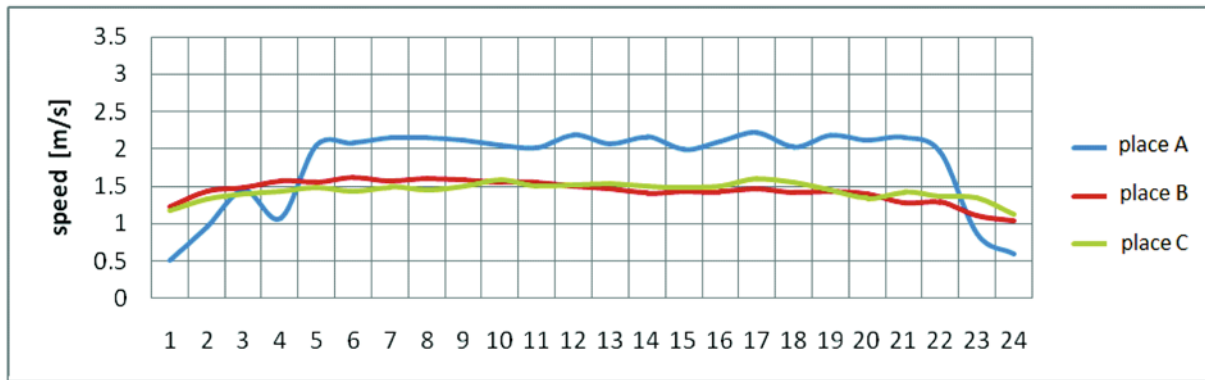

Graph 1 Measured speeds at parallel fan connection

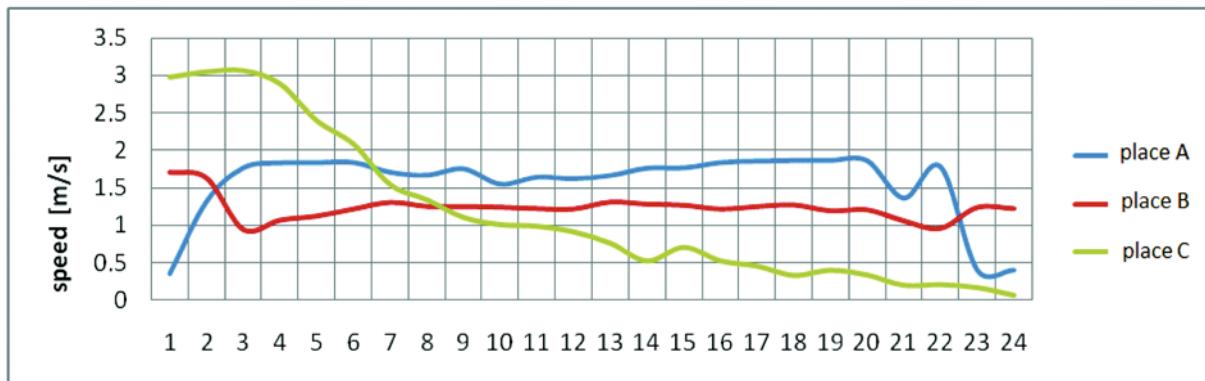

Graph 2 Measured speeds at  $2 \times 4$  parallel fan connection

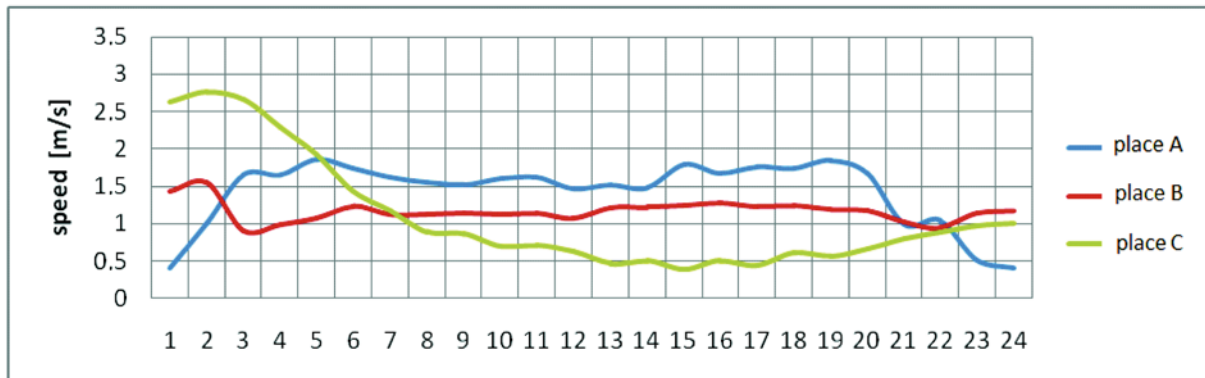

Graph 3 Measured speeds at  $4 \times 2$  parallel fan connection

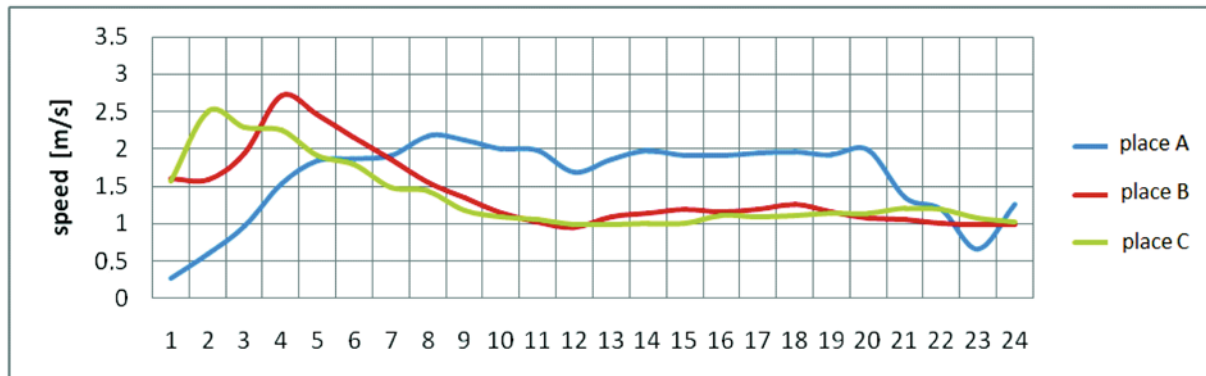

Graph 4 Measured speeds at serial fan connection

#### 4. Vibration measurement of jet fans and their analysis.

An important requirement placed on a jet fan is also its ability to ensure the required immediate ventilation of the road tunnel. When this requirement is not satisfied (because of the fan breakdown), the consequences can be fatal. The reliability and availability are then essential properties of this object [5].

The preventive maintenance can be seen as a relatively simple tool for increasing trouble-free operation and availability, using the information about the object condition, for example, by the measurement of its vibrations.

This maintenance strategy is an acceptable solution till the total cost of maintenance is not very high for the operating organization and they do not need to predicate a fault condition of the mechanism. However, the procedures of vibration diagnostics are able to provide data for prediction as well as information for proactive maintenance (on the base of which the reasons of failures are detected). Because of this reason, it is essential to deal with vibration diagnostics of fans. The sources of vibration for fans can be a rotor unbalance (it is indicated by a high vibration at  $1 \times \text{RPM}$  (rotation per minute) in the frequency spectrum), misalignment (angularity or offset) on the interconnection between the driver and the fan (with a high axial or radial vibration in spectrum on both  $1 \times \text{RPM}$  and  $2 \times \text{RPM}$  and  $180^\circ$  out-of-phase across the coupling), failure of bearings (detectable by significant peaks in spectrums at the bearing defect frequencies), or hydrodynamic processes caused by an unequal gap between the impeller and the stator of the fan (identifiable on the blade frequency of the machine) [6].

An electro motor is a source of vibration, too - stator eccentricity, short-circuited insulation and loose iron (stator problems become evident from high vibration at  $2 \times$  line frequency in spectrum), eccentricity of rotor (with side-bands with interval of pole frequency), broken or cracked rotor bars or shorting rings (presence of rotor bar frequency), phase problems - loosening of con-

nectors (side-bands with interval of  $1/3$  of the network frequency), etc. The properties of the framework are important, too, for example its mechanical looseness (multiples of the speed frequency in spectrum) or excitation of its natural frequency.

In the case of fans with a gearbox to the source of vibrations belong also meshing spur gears with considerable amplitudes on gear frequencies, their multiples and with their side-bands in the spectrums.

In Fig. 8 is depicted the frequency spectrum of oscillating speed with one dominant amplitude on the speed frequency of the fan which is typical for signature of the rotor unbalance of the fan.

The Faculty of Mechanical Engineering of the University of Zilina deals also with these problems, and we are able to offer our partners the solution of vibration measurements on fans. It does not have to be only the safety system switching off the fan after reaching a certain level of vibrations, but also the on-line, respectively on-line monitoring and analysis of the measured data from the point of view of predictive and pro - active maintenance.

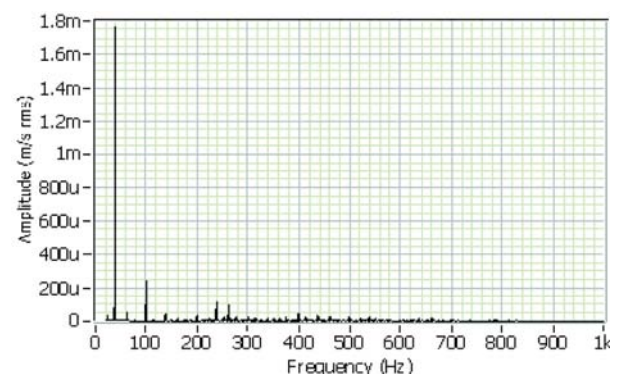

Fig. 8 Spectrum of oscillating speed with one dominant peak at 38 Hz, (speed frequency), demonstration of the rotor unbalance.

## 5. Conclusion

From the results presented above follows that the serial connection of 8 fans is the best option. The reasons for this are higher medium speeds as well as uniformities of the flow profile in the cross section of the tunnel. From the introduced analysis of mea-

surements on a physical model follows what a big influence the fan spacing has on the speed profile, which to a great extent influences the air transport in the tunnel. There is a real assumption that the spacing of fans on the course of the speed profiles has similar influences on the spacing of jet fans in real constructions of road tunnels.

## References

- [1] MALCHO, M.; JANDACKA, J.; PAPUCIK, S.; KAPJOR, A.; HORVATH, Z.: *Effect Slewing Jet Fan on Effectiveness Transport Air in Road Tunnel with Longitudinal Ventilation*, XXXVI. Setkani kateder mechaniky tekutin a termomechaniky; Herbertov, 2007, p. 35; ISBN 80-86786-09-9.
- [2] HORVATH, Z., JANDACKA, J., MALCHO, M.: *Extension of Fire in Tunel by Motor Vehicle Accident*, Proc. of Intern. Conference: Experimental fluid mechanics 2006, Liberec, Czech Republic, p. 79, ISBN 80-7372-141-4.
- [3] JANDACKA, J., MALCHO, M., HORVATH, Z., KAPUSTA, J.: *Longitudinal Ventilation Road Tunnel with Fire*, Zbornik prednask z 10. konferencie: Vetrание a klimatizacia 2006; Strbske Pleso, p. 87, (SSTP 0618), ISBN 80-89216-07-2.
- [4] JANDACKA, J., MALCHO, M., HORVATH, Z., KAPUSTA, J.: *Simulation Fire on Road Tunnel in Various Time Bracing Ventilating System Tunnel*, XV. Medzinarodna vedecka konferencia: Aplikacia experimentalnych a numerickych metod v mechanike tekutin, Strecno, 2006, p. 297, ISBN 80-8070-533-X.
- [5] DEKYS, V., SAPIETOVA, A., VASKO, M.: *Condition Monitoring of Gearboxes (in Slovak)*, Acta Mechanica Slovaca, Optimalizacia mechanickych sustav a zariadeni, 4-A/2007, pp. 67-74.
- [6] SILVA, C. W.: *Vibration, Fundamentals and Practice*, CRC Press LLC, 2000.
- [7] MOBLEY, R. K.: *Root Cause Failure Analysis*, Newnes 1999.
- [8] BERRY, J. E.: *Intensive Vibration Diagnostics*, SKF Condition Monitoring, Zaltbommel, 1985. Technical Associates of Charlotte, 1985.

Miloslav Klinko – Juraj Grecik \*

## TILTING BODY VEHICLES ON SLOVAK RAILWAYS – POTENTIAL FOR USE AND PARAMETERS TO BE CONSIDERED

*Competition between various transport modes has been a characteristic feature of the last decades not only in the world yet in Slovakia. Passenger rail transport proves to be most suitable for medium distances with high traffic intensity. In Slovakia this is valid first of all for Bratislava – Zilina – Kosice line. One solution for increasing travel speed and ride comfort is using the tilting body trains. In the paper theoretical considerations for use of tilting body vehicles are presented. On the example of Zilina – Kosice railway line we show a potential for remarkable reduction of travel time which is the most expected benefit of the new train technology, But we present also parameters which should be considered when thinking about use of new technology.*

### 1. Introduction

Competition between various transport modes has been a characteristic feature of the last decades not only in the world yet in Slovakia. Road and air transport are continually growing while railways seem to be declining. However, railway transport is always proclaimed to be a more environmental friendly and more efficient than the other ones, thus giving at least verbal support. But railway transport itself has to prove its benefits showing in reality which parameters are better comparing with other modes as well eliminate its weaknesses. Passenger rail transport proves to be most suitable for medium distances with high traffic intensity. In Slovakia this is valid first of all for Bratislava – Zilina – Kosice line, but other lines, especially connections to the Czech Republic are of interest as well.

In sixties of the 20<sup>th</sup> century most of leading railways in the world realised that if the railway traffic should withhold in competition with other traffic modes than passenger travel times should have been reduced substantially.

High-speed railway track can not be a universal solution for increasing speed. In a country with high population or mountainous terrain, or where government is not much in favour of investments into a new railway infrastructure, railway management have to find another way for ensuring the competitive travel speed.

As an example of market pressure is that in this situation vehicle designers were challenged to solve somehow the constraints given by conventional technology, geographical and financial conditions.

In leading countries of Europe, North America and Japan these problems were solved by development of a system using

tilting vehicle bodies that enabled the train running in curves at a higher speed.

### 2. Theoretical background of body tilting and running in curve

According to the second Newton's law, a body continues in its movement until external force is acting on it. As a consequence of external force action, a body will change its movement velocity and degree of this change is called acceleration.

Passenger trains normally have acceleration/ deceleration up to about 7 – 9 % gravity force (9 % g). This is given by adhesion acting between the wheel and rail.

For acceptable acceleration with respect to passenger comfort the maximum of something less than 10 % g is considered.

While instead of acceleration/deceleration on a straight track a train is turning into curve, the Newton law is still valid. Passenger bodies tend to continue in a straight line while the effect of transversal forces accelerates them in a new direction.

This “transversal acceleration” is more perceived by passengers than deceleration or acceleration rate. It occurs very frequently on a line with curves and its magnitude depends on the track shape and train velocity.

Same as acceleration, the transversal acceleration can be expressed in % g. Normally the transversal acceleration maximum value is 7 % g, which roughly corresponds to the train braking from speed of 160 km/h. In Switzerland, the country with railway

\* Miloslav Klinko<sup>1</sup>, Juraj Grecik<sup>2</sup>

<sup>1</sup>Department for Organization and Management, General-directorate ZSR, Bratislava, Slovakia, E-mail: Klinko.Miloslav@zsr.sk

<sup>2</sup>Department of Transport and Operating Technics, Faculty of Mechanical Engineering, University of Zilina, Slovakia

lines with numerous curves the maximum 9 % g is permitted, in France 8.6 % g, exceptionally, when for example, one curve should remarkably affect the speed, 12 % g is accepted.

Civil engineers can compensate the action of transversal acceleration by superelevation of the outer rail – cant of track. During running in a curve the combination (resultant) of transversal force and body mass acts in a direction slanted in a certain angle relative to the vertical. The balance apparatus in the human ear senses this angular tension as turning.

The superelevation was traditionally measured in inches and from Stephenson's era (on BR tracks with a standard rail gauge) one inch (25 mm) of superelevation corresponds to one degree of slant.

On a railway line with a combined traffic, size of superelevation in a certain curve is always a compromise. Too many slow trains on the lines cause an increased load on the internal rail and resulting increased wear of the wheels and rails, for speed trains the superelevation is limited by passenger comfort.

We should bear in mind that certain transversal acceleration is acceptable and trains are allowed to run in curves at a higher speed than corresponds to the balanced (compensated) acceleration. This uncompensated acceleration is known as cant deficiency.

The maximum speed at which the train is allowed to run in a curve is given by cant deficiency plus maximum superelevation (cant) for freight transport. Danger of overturning caused by transversal forces as a limiting factor need no be considered as this would happen at more than 20 degrees of cant (depending on a vehicle design).

Another important factor is the rate of change of the vehicle tilt as this has great effect on passenger comfort. Tilting effects can be measured in degrees per second. Experimental evaluation of how passengers perceive the tilting showed that at a rate of 5-6 degrees per second they begin perceive the tilting.

Very critical is the acting of tilt in opposite curves when train goes from a maximum superelevation/tilt on one side to a maximum on the opposite side. The British experimental tilting train APT was able to change from the tilt of 9 degrees and cant of 4.5 degree on one side to the similar values on the opposite side within three seconds, which was about 9 degrees per second. This has disturbing effects even in a sitting position. When standing and the rotation axle is in the level of knees, this can easily cause a person to fall down.

What is necessary is to somehow register tilting in advance. A simple and effective solution is placing the accelerometer on the first bogie of a train and to transmit the signals from there along the train with a corresponding delay for individual vehicles in the train. In this way each vehicle receives signal on tilt when it comes to the beginning of a transient curve. This solution is known as a preliminary registration and has also an advantage that it

enables reducing a number of processors and thus increases also reliability of the whole system. But the first vehicle still suffers from delay.

Fiat came probably with the best elaborated solution: besides the accelerometer the first bogie was equipped with a sensitive gyroscope and the apparatus for measurement of rail cant.

This gyroscope can register already the beginning of cant on a transient section and transmits the signal to the tilting mechanism. It will start working earlier than the transversal acceleration reaches the value that is registered by the accelerometer.

For trains of series X – 2000 developed by a Swedish company ABB, the solution is partly different: an instantaneous slant angle is measured for each vehicle. When a vehicle enters a section with a transient curve, the tilt angle is continually increasing towards the next vehicle. The signal that registers this difference of tilts is added to the signal transmitted from the accelerometer from the first vehicle. This system improves tilt control and enables more intensive action of the signal from the accelerometer. It is important for prevention of random transversal accelerations, e.g. in a straight track or on imperfect track conditions.

In the era of the first series of APT-P and similar trains problems of passengers were connected with an extremely high compensation of transversal acceleration. Soon it became evident that tilting is too perfect. A standing position or walking is possible thanks to the processing of information in human brains. During sitting in a train with a perfect compensation of transversal acceleration, signals from the inner ear say that the body is in erected position. When one looks out of the window, visual information does not correspond to this information as the train is slanted by 10 %. In that moment the brain registers stability problems and in sensitive individuals a phenomenon called nausea occurs, which may cause vomiting.

BR denied that this “nausea from tilt” would be any problem. But other railways found quite a simple answer: instead of the perfect compensation they introduced a tilting system compensating only 70 % of cant deficit, so the remaining transversal acceleration acting on passengers induced a feeling that they are moving in curve. As a consequence, the maximum tilt angle can be reduced and standard of manufacturers stabilised at 8 % – with exception of Pendolino system, in which ETR train is adapted for a tilt of 10 degrees plus 8 % g of an uncompensated transversal acceleration – and to 4.8 % cant deficiency.

### 3. Calculation of velocity of tilting body train

For speed trains so called unbalanced acceleration  $a_n$  is being used, which corresponds to the cant deficiency

$$a_n = \frac{70}{1500} \cdot g \quad \Rightarrow \quad a_n = 0.457 \text{ m.s}^{-2}$$

The basic formula for calculation of a maximum permitted velocity the following formula is used:

$$V = \sqrt{\frac{r}{11.8} \cdot (p_m + p_{np})} \text{ (km.h}^{-1}\text{)}$$

where

- $r$  - curve radius (m)
- $p_m$  - maximum superelevation (mm)
- $p_{np}$  - cant deficiency (mm)

A further increase of speed without reducing the passenger ride comfort ( $a_n = 0,457\text{m.s}^{-2}$ ) can be gained by tilting the car body inwards toward the curve by a certain angle  $\tau$ , which represents an additional superelevation  $p_d$ .

$$p_d = e \cdot tg \tau \text{ (mm)}$$

where

- $e$  - wheelset/rail contact distance (mm)

We get the permissible velocity with the use of a tilted body

$$V = \sqrt{\frac{r}{11.8} \cdot (p_m + p_{np} + p_d)} \text{ (km.h}^{-1}\text{)}$$

This is not a complete solution because the increase of velocity besides balancing the centrifugal force effecting passengers, brings an increase of vehicle effects on the track, too. The vehicle forces acting in a curve on the track, that is safety against derailment and track stability, become a dominant criterion.

Foreign railways use the Proud'hom's formulae when they prepare operation of tilting body vehicles. These formulae give limit of the maximum transversal force between the wheel and rail, which results in an unbalanced centrifugal acceleration of the vehicle  $a_{vn} = 1.65 \div 1.8 \text{ m.s}^{-2}$  and only exceptionally  $a_{vn} = 2.0 \text{ m.s}^{-2}$ .

A part of the transversal compensated acceleration  $a_{vk}$  is eliminated by the rail superelevation  $p_m$ , so the resulting transversal acceleration can be increased by this value. The maximum permissible speed of the tilting body vehicle will then be:

$$V_{dm} = v_{dm} \cdot 3.6 = 3.6 \cdot \sqrt{a_c \cdot r} \text{ (km/h)}$$

where

- $a_c$  - total transversal acceleration ( $\text{m.s}^{-2}$ )
- $a_{vk}$  - transversal compensated acceleration ( $\text{m.s}^{-2}$ )

$$a_c = a_{vn} + a_{vk} \text{ (m.s}^{-2}\text{)}$$

- $a_{vn}$  - uncompensated acceleration according to Proud'hom's formulae ( $\text{m.s}^{-2}$ )

$$a_{vk} = \frac{p_m}{e} \cdot g \text{ (m.s}^{-2}\text{)}$$

- $e$  - wheelset/rail contact distance (mm)
- $r$  - curve diameter (m)

Further on we need to determine how a big angle of the body tilt is needed.

$$a_c = a_{vk} + a_n + a_d \text{ (m.s}^{-2}\text{)}$$

where

- $a_n$  - unbalanced acceleration ( $\text{m.s}^{-2}$ )

$$a_d = a_c - a_{vk} - a_n \text{ (m.s}^{-2}\text{)}$$

- $a_d$  - additionally compensated acceleration ( $\text{m.s}^{-2}$ )
- $p_d$  - additional superelevation (mm)

From the following formula we get the required angle of a body tilt:

$$p_d = \frac{a_d}{g} \cdot e \quad tg \tau = \frac{p_d}{e} \Rightarrow \tau \text{ (}^\circ\text{)}$$

#### 4. Computer simulation of a train run

One of the most important steps in the decision process on the use of tilting body vehicles is also a theoretical calculation of run parameters on the proposed railway line section.

For this calculation we used a program "Train dynamics". Parameters of the selected railway line section have to be input into the program.

##### A) Input data of the program comprise:

1. Parameters of a selected railway line section
2. Type of locomotive (or traction vehicle)
3. Type of train
4. Complementary data:
  - Braking deceleration
  - Traction force limit
  - Limit of push force
5. Specific data:
  - Integration step
  - Minimum coasting speed
  - Specific heating power
  - Coefficient of relative decrease of speed during coasting
  - Distance step for data output

##### B) Results of a sample calculation

After correctly performed calculation we can show the results in the form of a table or diagrams. In the table, besides travel time, the total energy consumption in kWh or diesel in litres can be presented. For electric locomotive the consumption is given without consumption of auxiliary drives and heating. These items can be considered either by a coefficient or by additional calculation.

The obtained data from the simulation of a train run are certainly only theoretical, but they can provide a starting point for comparison of various types of train sets and testing their para-

meters from the point of view of their suitability for the selected railway line section.

As an example of the train run simulation using the computer program "Train dynamics" we chose a railway line section Zilina - Kosice, as this section has a considerable number of curves with small radii. (We used the parameter  $1/r$ ;  $r$  - track curve radius).

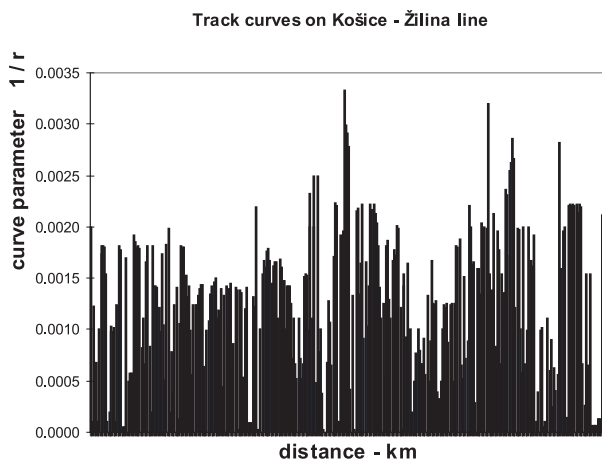

Fig. 1 Track curves on Kosice-Zilina line

We compared the train sets with corresponding weights:

- Conventional - locomotive series 163, plus passenger cars of total weight of 400 t, totally 484 t.
- With a tilting body - train-set series ETR 470, total weight of 490 t, permanent power of 5880 kW, maximum traction force 258 kN

Although the power of locomotive series 163 is remarkably lower, for the maximum speed of 120 km/h currently used on given railway lines this locomotive is good enough. Calculated travel times for the conventional locomotive-hauled train and Pendolino train set series ETR 470 on the lines with existing speed limits do not differ by more than 1% in favour of Pendolino, which is a negligible difference. However, benefits from the increased speed in

Table: Travel times and energy consumption on selected sections

	Track sections existing state		Existing sections for tilting body vehicles		Theoretical sections for tilting body vehicles	
	Travel time (min)	Energy consumption (kWh)	Travel time (min)	Energy consumption (kWh)	Travel time (min)	Energy consumption (kWh)
163 + 400 t	154.1	2374	-	-	-	-
ETR 470	153.6	1626	110.7	1879	102.3	2776

curves confirmed the results of simplified calculations; although, the difference, according to a more precise calculation, was a bit smaller. Moreover, in these calculations we considered speed limits in the same sections as they are at present, yet we also used theoretical speed limits for each curve while certainly the maximum speed of train ETR 470, which is 200 km/h, could not be exceeded. Selected calculation results are in the following table.

The diagram of a run diagram and energy consumption on Košice - Zilina line, theoretical sections (considering maximum possible theoretical speed in each curve on the line) is presented in the figure below:

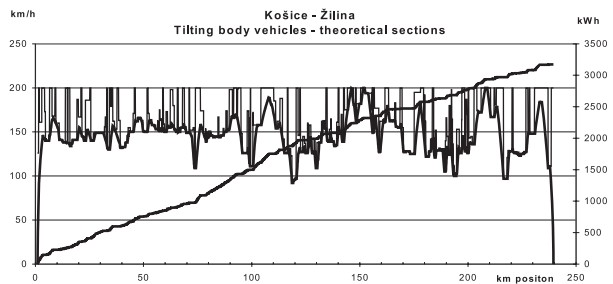

Fig. 2 Tilting body vehicles - theoretical line sections (Kosice - Zilina line)

In case of theoretical speed limits for each curve increased energy consumption has remarkably gone up, as there were frequent changes in velocity (acceleration in the sections with a higher permissible speed).

### 5. Parameters effecting choice of a suitable rail vehicle

In the decision process on suitability of the use of a selected railway vehicle type on a given railway line it is necessary to investigate not only design parameters of the vehicle but also other parameters concerning its operation have to be considered as well.

These parameters in principle can be divided into the following categories:

- Technical parameters:
  - parameters of railroad tracks and buildings
  - parameters of interlocking systems
  - parameters of traction power supply and electrotechnical equipment
- Parameters of effects on environment railroad surroundings
- Parameters of effect on passengers
- Economic parameters
  - Operational and maintenance costs
  - Disposal costs
  - Costs for increasing quality and reliability
  - Competitiveness with other transport modes

**Technical parameters**

These parameters are based on valid legislation (regulations, standards,...) and mostly in a designing phase of a suitable type of railway vehicle it is not possible to influence these parameters as their change requires high investments for modification of the railway track and other connected technical facilities. Moreover, these parameters directly affect the operational safety of the rail vehicle.

**Parameters of effects on environment railroad surroundings**

Parameters of effects on environment railroad surroundings are also given by valid legislation but they can be affected by a vehicle design and its maintenance system. The main parameters belonging to this group are especially:

- Noise emitted by the vehicle;
- Influence on soil, water and air pollution.

**Parameters of effect on passengers**

These parameters are most important from the point of meeting passenger needs. They concern namely:

- Personal comfort during the train run
- Speed of transport from place A to place B
- Train ticket price
- Traffic safety

**Economic parameters**

Economic parameters are the most important for assessment suitability of the use of a railway vehicle on the given railway line as operation should be economically effective. Individual types of costs related to the rail vehicle operation can be affected already during the design phase.

When considering the individual parameters with the aim of choice of the most suitable type for a given railway line it is good not to focus only on one parameter that looks like the most important, but all the parameters should be evaluated and considered in their mutual connection. This is valid also for usage of tilting body vehicles when one important parameter – an increased train velocity should be considered with all the induced requirements for operation of this train technology.

**References**

- [1] SIMCO, J.: *Employment Tilting Body Trains - Alternative for Raising Speed in Railway Transport (in Slovak)*, Horizonty dopravy 3/2002, Zilina, p. 1-8
- [2] SIMAN, P., PETRAS, J.: *Programme „SP Dynamika“ (in Czech)*, Computer program, Praha, 1998
- [3] GRENCIK, J., KLINKO, M.: *Potential Reduction of Travel Times and Energy Consumption of Tilting Body Vehicles on ZSR*, Communications - Scientific Letters of the University of Zilina, 1/2001, EDIS Žilina, p. 88-97.

Bojan Cene – Aleksandar Radosavljevic – Branislav Gavrilovic \*

## DRIVING ENERGY CONSUMPTION OF ELECTRIC TRACTION VEHICLES

*The paper presents some simulation and tests results of driving energy consumption of electric traction vehicles both at Serbian and Slovenian Railways. On Serbian Railways there are two series of electric locomotives: four-axles 441 series made in former Yugoslavia under license of ASEA (Sweden) and six-axles 461 series manufactured in Romania in co-operation with ASEA. On Slovenian railways are four series of electrical locomotives operating: the Italian two axles locomotive series 342, the Italian six axles locomotive series 362, the French six axles locomotive series 363, and the three-system four axles Siemens locomotive series 541.*

*Keywords: energy consumption, electric traction vehicles, Slovene railways, Serbian railways, GPS*

### 1. Introduction

The problem of driving energy savings during train traction became very significant during the energetic crisis and therefore all foreign railways have conducted wide researches in order to find a solution of this problem. Apart from technical improvements of tractive and hauled stock these researches have also been conducted in the field of software development for finding optimal energetic train running trajectories. Considering the fact that the most of the driving energy rationalization possibilities have already been used the subject of the newest researches has become the way of train running (for the given line the running regimes with the low or the lowest possible energy consumption are chosen with all the other conditions defined by the timetable unchanged). With the optimal way of running it is possible for the train to run on the given line according to the given timetable and with minimal energy consumption. The optimization results are used for making and maintaining the optimal energy timetables.

In Serbia such work was done by the Institute of Transportation CIP (SI CIP) and verified on the Serbian Railway network (ZS) [1, 2].

The co-author in Slovenia is executing the inspectorial supervision of operation and maintenance of railway vehicles in Slovenia.

### 2. The state of the electric traction vehicles in Serbia and Slovenia

The first electric locomotive, 441 series (Fig. 1) (four-axle  $B'_o B'_o$ ), was put in exploitation on the former Yugoslav Railways network in the mid of 1970. In 1971, a large number of them were

delivered for the same network. "Rade Koncar", the enterprise from Zagreb, manufactured those locomotives, licensed by ASEA, Sweden. Six-axle ( $C'_o C'_o$ ) electric locomotives, 461 series (Fig. 3), were manufactured in the mid of 1972 in Resice, Romania in co-operation with the ASEA. They were delivered for the "eastern" part of the former Yugoslav Railways (ZTP Belgrade, Skopje and Podgorica) [3].

The locomotives use single axle drive and diodes in drive control system. Electric locomotives series 441 are developed for speeds of 120 and 140 km/h (the ratios between the cog number of the smaller and the larger cog-wheel are 20:73 and 28:87) and series 461 for the speed of 120 km/h only (20:73). The electric equipment is constructed to work with single-phase alternate current with nominal voltage of 25 kV and frequency of 50 Hz. Both series have two driver's cabs, one on each locomotive end, which are used on electrified lines for passenger and freight train traction.

30 diode electric locomotives series 441 had been modernized into thyristor locomotives series 444 (Fig. 2) between 2004 and 2007 in the company "Rade Koncar", Zagreb. New modern equipment is built into locomotives leading to improvements in performance, reliability and availability. Modernization had included substitution of all relay equipment with microprocessors for locomotive control, protection and diagnostic of malfunctioning with messages and instructions for maintenance. The old step regulation of traction motors was replaced with continuous control of tractive effort based on thyristor elements.

The following objectives are intended to be achieved by modernization: lifetime extension, improvement in service parameters, service cost reduction, better working environment for drivers,

\* Bojan Cene<sup>1</sup>, Aleksandar Radosavljevic<sup>2</sup>, Branislav Gavrilovic<sup>3</sup>

<sup>1</sup>Ministry for Traffic, Ljubljana, Slovenia, Email: bojan.cene@gmail.com

<sup>2</sup>Institute of Transportation CIP, Belgrade, Serbia

<sup>3</sup>Serbian Railways, Belgrade, Serbia

high unification of equipment on locomotives of series 441 and 461 and maintenance cost reduction. Total number of locomotive series 441 is 76 (441: 46, 444: 30) and of series 461 is 53.



Fig. 1 The electric locomotive series 441



Fig. 2 The electric locomotive series 444



Fig. 3 The electric locomotive series 461

The fourth (four axles  $B'_0 B'_0$ ) locomotive of the DC System 3 kV, series 342 was manufactured by Ansaldo Italy and has been operating in the region of Slovenian Railways since the year 1968 (Fig. 4). The next (six axles  $B'_0 B'_0 B'_0$ ) DC system locomotive series 362 was also manufactured by Ansaldo Italy and has been already operating in Slovenia since the year 1960 (Fig. 5). The French locomotive (six axles  $C' C'$ ) series 363 has been operating in Slovenia since the year 1975 and is still representing the most frequent electric locomotive on the Slovenian railways today (Fig. 6). In



Fig. 4 The electric locomotive series 342



Fig. 5 The electric locomotive series 362



Fig. 6 The electric locomotive series 363



Fig. 7 The electric locomotive series 541

the year 2006 in Slovenia started operating the three-system (four axes  $B'_0B''_0$ ) Siemens electric locomotive series 541, factory designated as ES64U4. It can operate in the following electric traction systems: DC system 3 kV, single phase AC system 25 kV, 50 Hz and single phase AC system 15 kV, 16 2/3 Hz (Fig. 7).

The Italian locomotives series 342, rated output 2 MW and series 362, rated output 2.65 MW are classic resistance electric locomotives, which are slowly terminating their service in Slovenia. The locomotive 363, rated output 2.75 MW is a more up-to-date resistance locomotive with gear transmission of power across a reduction gear to the wheel sets. This locomotive is still expected to operate for approximately ten more years. The Siemens locomotive series 541 is an interoperable locomotive and was acquired for operation on the railways in Slovenia as well as in neighbouring countries. It is equipped with static convertors in transistor version.

### 3. Definition of the train movement differential equation

Train movement equation represents the dependence between the train acceleration and the efforts exerted during the train running. The train movement equation is the basis for solving all the traction-energy tasks. Some of them are: running times, driving energy consumption, determination of the corresponding train load for the given line, determination of the optimal energy running times, etc. The train movement equation is based on the well-known mechanics rule: elementary work of efforts exerted on the running train (resultant efforts) is equivalent to the elementary increase (or decrease) of quantity of motion [1]:

$$dA = dE \tag{1}$$

Where:  $dA$  [Nm] - elementary work of the resultant effort;  $dE$  [Nm] - elementary change of the live effort-train kinetic energy.

During running the train is exposed to influence of different efforts (considering the intensity and direction) but its movement is the result of influence of the resultant effort. When the train movement speed is changed the wheel rotating and rotating masses speeds that are rotating according to the train movement are also changed. Train movement equations are as follows:

$$M' \frac{dV}{dt} = 10^{-3}(F_v - F_k - W_o - W_d) \tag{2}$$

$$V = \frac{dx}{dt}, \tag{3}$$

Where:  $V$  [m/s] - train speed,  $x$  [m] - distance,  $t$  [s] - time,  $M'$  [ $t/m/s^2$ ] - weight coefficient of the train,  $F_v$  [daN] - tractive effort at the wheel rim,  $F_k$  [daN] - braking effort of the train,  $W_o$  [daN] - basic train resistance,  $W_d$  [daN] - additional resistance.

Additional resistance (Fig. 8) is the one that arises from the line gradient and its curve radius and the basic resistance is the one that arises during the vehicle movement (with defined speed along the straight and horizontal line considering the average weather conditions).  $M'$  value is as follows:

$$M' = \frac{Q_L(1 + \epsilon_L) + Q_K(1 + \epsilon_K)}{g} \tag{4}$$

Where:  $Q_L$  [t] - locomotive weight ready for service,  $Q_K$  [t] - load hauled,  $\epsilon_L$  - rotational inertia coefficient of a locomotive,  $\epsilon_K$  - rotational inertia coefficient of coaches,  $g = 9,81$  [ $m/s^2$ ] - gravitational acceleration.

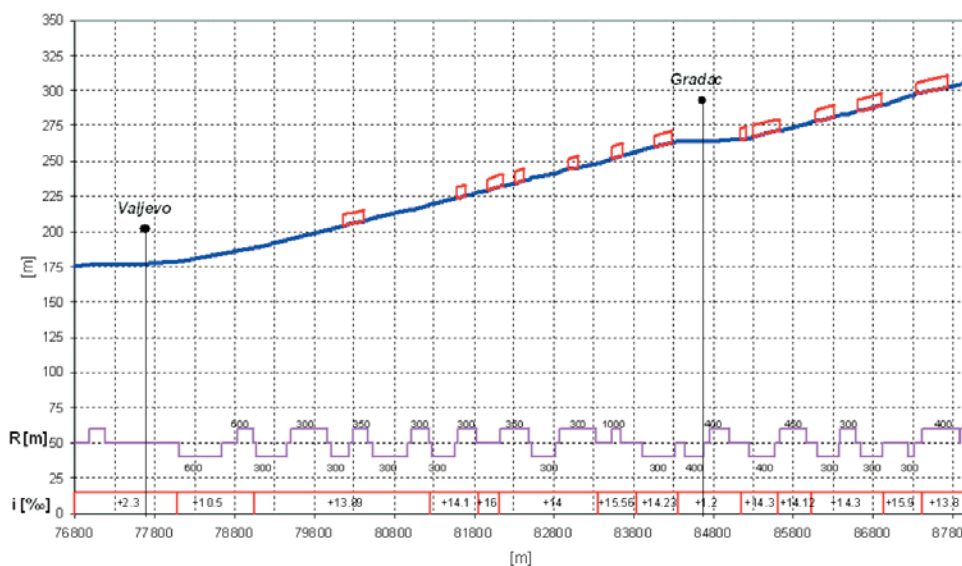

Fig. 8 Additional track resistance

If we choose  $10^3/g \sim 10^2 \text{ s}^2/\text{m}$  and if we take specific resistance instead of basic ones the movement differential equation can get the following form suitable for further manipulation:

$$102(1 + \varepsilon_v)Q_v \frac{dV}{dt} = F_v - F_k - (Q_L w_{oL} + Q_K w_{oK}) - Q_v w_d \quad (5)$$

Where:  $\varepsilon_v$  - rotational inertia coefficient of a train,  $Q_v$  [t] - total train weight,  $w_{oL}$  [daN/t] - specific basic resistance of locomotive,  $w_d$  [daN/t] - specific additional train resistance,  $w_{oK}$  [daN/t] - specific basic resistance of railway carriages.

The values  $Q_v$  and  $\varepsilon_v$  satisfy the following equation:  $Q_v = Q_L + Q_K$ ,  $\varepsilon_v = \frac{Q_L \varepsilon_L + Q_K \varepsilon_K}{Q_v}$ . This train movement differential equation is used for the calculation of the train running time and traction energy consumption.

#### 4. The software for electric locomotives runningsimulation

The software for optimization of the electric locomotive control for the driving energy savings purposes is based on the following methodology elements:

(1) The real problem analysis has taken into consideration numerous factors (parameters) which affect the driving energy consumption (railway line, train type and locomotive series).

(2) During the examination of the relations between the given factors the corresponding functional dependencies were determined and formalized and they represent the mathematical model of the real problem. The basis of this model are the train movement differential equations whose structure is very complex and unsuitable for the use of the well-known analytic methods for their solving. Apart from the differential equations the mathematical model also consists of numerous algebraic, logical and other relations that are needed for better understanding of the real problem.

(3) For the solution of the optimal control problem described with the mentioned mathematical model numerical methods for differential equations solving must be used. Therefore, the Runge-Kutta method for differential equations of the fourth degree was used. Algorithm also has the procedures for determination of running time, distance, instantaneous speed and acceleration, amount of released energy during electric braking, consumed drive energy and the other factors that concern train running. Calculations are made in the discrete time points (according to the solution of the movement differential equations) from the starting to the stopping time on the given line. Given procedures are done through the following elementary drive regimes: (a) train starting, (b) train acceleration, (c) train movement with maintaining the

constant speed by traction or electric resistance or pneumatic brake or combined electric and pneumatic brake, (d) coasting and (e) braking. Every complex drive can be divided into several elemental regimes. Therefore, the global algorithm is made in such a manner that each of the mentioned regimes represents one complete module, which can be activated as needed.

User is offered to choose one of the following ways of train running on the given line: train running with lowest running times and highest driving energy consumption, train running with the limited traction motors current (for instance,  $I = 1000 \text{ A}$ ), train running with the combination of the lowest running times and the use of inertia where it is possible and technically justified and train running with the limited traction motors current and the use of inertia where it is possible and technically justified.

A keyboard is used for entering parameters that describe each running simulation. Some of them are: name of a line, train form (express, passenger or freight), train weight, train length, locomotive type (441 or 461), maximum locomotive speed, maximum traction motor current, percentage of braking and working variant. All other parameters are grouped in the three input files: train parameters file, file with the data describing the locomotive and the file with the data describing the characteristics of railway line.

As a result of the simulation two files with the .E and .R extensions are made and they hold the important simulation values.

The marks in the data columns from the file with the .E extension (data for stations) have the following meaning:  $s$  [m] - station distance,  $dt$  [min] - running time between stations,  $t$  [min] - cumulative running time between stations,  $t+5\%$  [min] - cumulative running time between stations increased for 5% because of traffic irregularity,  $V$  [km/h] - train speed through station,  $V_{max}$  [km/h] - maximum permitted train speed through station,  $w$  [daN/t] - specific basic track resistance,  $n$  [1/min] - revolutions per minute of traction motor,  $F$  [kN] - locomotive tractive effort,  $I$  [A] - traction motor current,  $U$  [V] - traction motor voltage,  $E$  [kWh] - consumed energy for train traction,  $RE$  [kWhr] - consumed reactive energy for train traction.

The marks in the data columns from the file with the .R extension (data for travelling regimes) have the following meaning:  $s$  [m] - distance of changing travelling regimes,  $w$  [daN/t] - specific basic track resistance,  $dt$  [min] - running time between two travelling regimes,  $t$  [min] - cumulative running time between two travelling regimes,  $t+5\%$  [min] - cumulative running time between two travelling regimes increased for 5% because of traffic irregularity,  $V$  [km/h] - train speed,  $E$  [kWh] - consumed energy for train traction,  $RE$  [kWhr] - consumed reactive energy for train traction,  $I_{koc}$  [A] - braking current of traction motor acting as a generator,  $E_{koc}$  [kWh] - energy dissipated using electric resistance brake,  $T_{koc}$  [min] - time of electric resistance brake usage,  $I_p$  [A] - traction motor excitation current, Travelling regime-corresponding travelling regime.

5. Results of simulations and experimental tests

On the Serbian Railway network there are different lines considering the field configuration: level, mountain and mixed. The Belgrade (Resnik)-Bar line is a typical mountain line with numerous up and downgrades and the small curve radiuses ( $R = 300$  m). This track, which is 405.1 km long, has 558 changes of specific resistance. The longitudinal line section is adapted for computer simulation by its reduction without connection of the successive related sections. The other line elements, such as: maximum section speeds, train stops in stations, restricted-speed running, etc. are used according to the timetable.

Simulation of various freight trains running hauled by electric locomotives series 441 and 461, is done to estimate the total running time and consumed energy for the train traction. Simulation is done on these lines: Beograd ranzirna "A" - Mala Krsna

( $Q_V = 1160$  t), Nis - Tabanovci ( $Q_V = 1160$  t), Beograd ranzirna "B" - Lapovo ranzirna ( $Q_V = 800$  t), Mala Krsna - Rakovica ( $Q_V = 600$  t), Resnik - Podgorica ( $Q_V = 1000$  t, Fig. 9, 10) and Podgorica - Resnik ( $Q_V = 1060$  t). On the basis of the obtained values we can conclude that average specific consumed energy for the locomotive series 441 is about 25.5 Wh/brtkm and for the locomotive series 461 is about 35.1 Wh/brtkm [4]. In the case of passenger trains the specific consumed energy for train traction is higher by about 30% and more.

The Slovenian Railways have started to install up-to-date digital equipment for metering and reading the energy consumption with the use of the GPS system on electric traction vehicles. The operating principle is shown in Fig. 11.

The following equipment is installed on the locomotive: Energy meter LEM EM4T, voltage transductor type LEM CV 4-6000/SP1,

STATION	s	dt	t	t+5%	V	Vmax	w	n	F	I	U	E	RE
(kWhr)	(m)	(min)	(min)	(min)	(km/h)	(km/h)	(daN/t)	(1/min)	(kN)	(A)	(V)	(kWh)	
Resnik	0	0.00	0.00	0.00	0.0	0	3.12	0.0	0.00	0.0	0.0	0.0	0.0
Bela Reka	7632	7.00	7.00	7.34	69.5	70	2.50	1112.2	43.74	355.5	393.2	417.3	288.5
Bioce	389571	8.42	324.33	340.55	74.5	75	-1.08	1192.4	17.71	247.4	307.6	12462.0	8672.8
Podgorica	405100	12.00	336.33	353.15	0.0	0	0.00	0.0	0.00	0.0	0.0	12644.5	8804.0

Fig. 9 Data for stations

REGIME:	s	w	dt	t	t+5%	V	E	RE	Ikoc	Ekoc	Tkoc	Ip	TRAVELLING
	(m)	(daN/t)	(min)	(min)	(min)	(km/h)	(kWh)	(kWhr)	(A)	(kWh)	(min)	(A)	-
	0	3.12	0.00	0.00	0.00	0.00	0.0	0.0	0	0.00	0.00	0	Starting
	147	3.12	0.40	0.40	0.42	31.86	21.1	14.0	0	0.00	0.00	0	Acceleration
	726	10.17	0.63	1.03	1.08	69.50	83.9	51.1	0	0.00	0.00	0	V=Const/by
traction	8640	4.45	0.52	8.00	8.40	69.50	456.3	317.8	0	0.00	0.00	0	Acceleration
	9190	4.45	0.40	8.40	8.82	84.50	504.1	347.3	0	0.00	0.00	0	V=Const/by
traction	12220	-5.43	2.15	10.55	11.08	84.50	577.0	402.6	0	0.00	0.00	0	V=Const/by
braking	12220	-5.43	0.00	10.55	11.08	84.50	577.0	402.6	319	0.00	0.00	43	Electric braking
	12877	-5.43	0.47	11.02	11.57	84.50	577.9	403.2	318	1.99	0.47	43	Electric braking
	404629	0.00	0.46	335.86	352.66	89.50	12643.5	8803.4	0	2136.74	77.04	0	Pneumatic braking
	405100	0.00	0.47	336.33	353.15	0.00	12644.5	8804.0	0	2136.74	77.04	0	End of line

Fig. 10 Data for travelling regimes

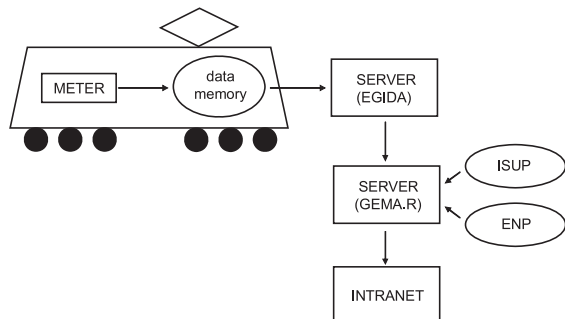

Fig. 11 Measuring of consumption of energy on electric locomotives on Slovene railways

and current transductor type LF 2005-S/SP9. The consumed energy is read by the data memory, in which the data on consumed energy and data from GPS are combined. These data are sent to the server EGIDA (where the data of all electric locomotives are collected). From there the data are sent to the server GEMA.R, which unites all the data from the information system of traffic performance (ISUP) and from railway substations (ENP). The data on the consumer are sent to the INTRANET [5].

In the continuation, the analysis of the run of the train No. 47408, with a mass of 1708 tons and with a locomotive series 363 - 004 is shown for the trip from Ljubljana to Maribor on 14 September 2007. For better understanding the analysis of energy consumption of this train is given only for the distance travelled from Ljubljana to Ljubljana Moste (Table 1) [6].

Analysis of electricity consumption at train 47408 on railway line Ljubljana - Ljubljana Moste Table 1

Consumed [kWh]	Regenerated [kWh]	Track section	Speed [km/h]	Width [m]	Length [m]
1	0	Ljubljana	0	46.0588	14.5267
1	0	Ljubljana	0	46.0588	14.5267
0	0	Ljubljana	17	46.0588	14.5279
20	0	Ljubljana - Ljubljana Moste	35	46.0589	14.5339

The fifth and the sixth column in the table represent the width and the length of data acquisition from the locomotive by the GPS equipment. The GPS system divides the area of movement of the locomotive into small squares and each such square indicates transmitted information about the energy consumed from the locomotive to the centre. It must be taken into consideration

that the GPS does not recognize the curve of the railway track in the moment of reading, but it works along the bee-line. Therefore the accuracy of this system amounts to approximately 94 %. If the number of squares is increased, the squares become smaller and a more accurate result is obtained.

Over the total distance of 156 km the electric energy consumption for this train was 2893 kWh. This energy consumption amounts only to 10.89 Wh/brtkm which is much less than average consumption of 35.1 Wh/brtkm with 461 series locomotives. This is due to differences in railway line difficulty. Line Ljubljana - Maribor has no ascending slopes, for the most part there is a downgrade of 10 %. Lines of the Serbia railways, for which these measurements are made, are mainly steep with a slope up to 27 %.

Line Koper - Divaca in Slovenija with a slope up to 26 % energy consumption with 363 series locomotives amounts about 45 Wh/brtkm.

6. Conclusion

The software for the electric locomotive optimization control for driving energy savings purposes enables the user to find the optimal combination (according to his needs) of the changeable train traction parameters. Almost every train traction parameter is changeable: locomotive series with all characteristic parameters (wheel usage percentage, rotation masses affect factor, nominal traction motors voltage value, continuous and maximum traction motors current, efficiency of cog-wheels, deformation factor, locomotive active and apparent power on the pantograph, etc.), line elements (maximum speeds, stopping, restricted-speed running, length of stops in stations, track resistance, etc.). The amount of the output results is bigger than in all the other projects done so far. The train running simulation time is considerably shorter than in all other traction-energy calculation methods known so far. The simulation results can also be used for making the regime card of each train run in the whole timetable diagram.

In order to verify in practice the calculated driving energy consumption of electric locomotives at the Serbian Railway numerous measurements are conducted on the tracks. These measurements show high coincidence between theoretical and practical results.

The software for train driving energy consumption is also applied on the diesel locomotives and the only electric-motor train series ZS 412/416 for urban-suburban traffic on the Serbian Railways.

For this manner of analysis of consumption electricity energy are decided in Slovenia because of larger number of carriers.

**References**

- [1] RADOSAVLJEVIC, A. et al.: *Optimization of Running Electric Locomotives Series 441 Because of Driving Energy Savings (in Serbian)*, SI CIP Belgrade, 1991
- [2] RADOSAVLJEVIC, A., MILUTINOVIC, D., BECEJAC, L.: *Simulation of Electric Locomotives Running for the Driving Energy Savings Purposes*, Fourth International Conference Drives and Supply Systems for Modern Electric Traction in Integrated 21<sup>st</sup> Century Europe, Warsaw, Poland, 23-25 September 1999, pp. 226-230, 1999
- [3] RADOSAVLJEVIC, A., KOZULJ, T., BECEJAC, L.: *Technical and Operational Characteristics of Traction Units on Yugoslav Railways (in Serbian)*, Zelnid, Belgrade, 1998
- [4] RADOSAVLJEVIC A., MILUTINOVIC, D., JOVANOVIC, R., LUCANIN, V.: *Experimental Determination of Mixed Feight Train Running Resistance and Influence on Energy Consumption*, 6<sup>th</sup> World Congress on Railway Research WCRR 2003 - Topic: Interactive Systems and Environment - Session: Energy Emissions, Edinburgh, Scotland, 2003, pp. 40-47, 2003
- [5] DREMELJ, B.: *Onboard Metering Electricity Consumption System Architecture and Data Paths (in Slovenian)*, 2006
- [6] Slovene Railways, Intranet - Data Concerning Train, No 47408 from day 14.09.2007.

Radomir Brkic – Zivoslav Adamovic \*

## THE IMPLEMENTATION OF SAFETY AND RELIABILITY OF DATA TRANSMISSION IN RAILWAY SIGNALLIZATION SYSTEMS

*The focus of this paper is the safety and reliability of data transmission in railway systems at increased and high train speeds by means of technological devices of new generation. Routes in railway traffic are protected with new microprocessing signalling devices, the reliability and availability of which, thanks to new technology, may be projected to a necessary, i. e. desired value.*

*Key words: ETCS, automatic control, automatic guidance, safety, reliability, availability.*

### 1. Introduction

So far, the conventional signalling system that involves fixed distances between the main signals and pre-signals makes the given task harder and limits the existing riding power of the rail. Contrary to this, the ETCS (European Train Control System) – supported line train leading – is independent of dividing the railroad into track sections and it provides the possibility of viewing the actual condition of the railroad ahead and with no limits.

Although mixed traffic railroads would require keeping of the conventional signals in the initial period – because of the lower speed freight trains – as emergency and lower hierarchy level in case of a main system failure, the main automatic leading system works as an ‘overlay-system’ representing the first safety system controlled by software.

### 2. Concept of an electronic signal box

Very important advantages of electronic signal boxes lie in the possibilities offered by a system-specific application of modern processing technology. Other than this, these advantages include:

1. Lower purchasing value of the device;
2. Considerably reduced construction requirements and fixed equipment;
3. Minimized scope of maintenance;
4. Ensured unification of work places for the train dispatchers – independent of the equipment supplier – and high level ergonomic equipment in the work places of dispatchers and the operative center dispatchers;
5. Simple integration of additional automatization and dispoing functions; standardization of the interface for computer systems higher up in the hierarchy;
6. Creating conditions necessary for an integrated system of automatic leading.

### 1.1. Starting points for the safety microcomputer module

Possible places of application for the safety microprocessor module – safety microcomputer – are:

- the electronic signal box, the vital ETCS computer
- the terminal computer for handling signals and branches
- the vital element of every module and the main element in the safe signal transmission and crypto communication.

All these places in the signal structure differ very much in the quantity of the hardware necessary for the main module, software necessary in relation to the function it performs, factors of the environment, necessary reliability, etc.

Therefore, a global developing aim can be defined as follows:

- To develop a microprocessor module for those application places in the field of rail signallization where the systems i.e. subsystems must be fail-safe;
- To construct a ‘hard core’ that can be programmed by the ‘main program’ to work fail-safe invariably, regardless of the location of the application places;
- To compose the module from reliable components of the leading world producers;
- To achieve an MTBF ‘reasonably’ longer than 1 year, that is between 10,000–15,000 hours.

Unlike the so far safety signalling systems based on relays, there are neither electronic components, nor systems that can be found on the market which show the necessary ‘fail-safe’ behavior. Since the processor itself has no inherent safety, an adequate concept must be found to guarantee fail-safe behavior using ‘redundancy’ – which in fact means the management and control of the managing hardware with one special unit capable of detecting all functional mistakes that may cause danger to the process.

\* Radomir Brkic<sup>1</sup>, Zivoslav Adamovic<sup>2</sup>

<sup>1</sup>Railway College Belgrade, E-mail: rbrkic@drenik.net

<sup>2</sup>Technical Faculty, Zrenjanin, Serbia

The processing results from the two systems are compared and in case they are not identical, the comparing function itself and the next safety action must redirect the system into a safe-side position. This concept is possible with the configurations '2 out of 2' and '2 out of 3'.

These are the main problems that every system must solve and the 'internal mechanisms' that must achieve the above fail-safe behavior:

- Every single failure must be identified and must result in a safety reaction of the system;
- Double or multiple failures cannot happen if the safety concept of the system enables full comparison of results (during the entire course of the processing, and not only at its end) and condition of both channels, including memories;
- Not a single failure in one channel can have a similar effect on the other channel. The channels must be independent from each other;
- Both channels and the whole module must be completely tested and with no mistakes in either hardware or software before releasing the system into work. In other words, the system must be guaranteed as mistake-free before starting up the system.

Fig. 1 shows an illustrative example of a basic two-channel configuration of the safety microcomputer by Siemens Company. This configuration is safe-designed so that the two identical microcomputers work in synchrony with their:

- Central processing units CPU 1 and CPU 2;
- Belonging memories for entering and reading of the RAM 1 and RAM 2 data;
- Memories which are programmed for fixed values that can be reprogrammed as needed, EPROM 1 and EPROM 2;
- The configuration contains common ingoing and outgoing modules;
- Reception (1) and Release (2) which establish connection with the exterior elements; the system has one common tact-giver to synchronize the work of the two identical channels.

The system checks if the signals from both channels are identical in every tact step, in the following way: the tact-giver turns on both processors (TACT 1 and TACT 2) and a comparator ('C' signal - control in Fig. 1) The comparator checks the content of the collectors in both microcomputers (BUS 1 and BUS 2) and compares them. Only in case that the comparator (in every tact) establishes the identical status of both channels, it generates the signals "OK" (no mistake) on its exit, which triggers the next working cycle of the tact-giver.

Otherwise, in case there is any discrepancy in the signals coming from Channel 1 and Channel 2, which is transparently shown on BUS 1 and BUS 2, or in case of any mistake on the comparator, the comparator 'chokes' the 'OK' (no mistake) signal driving the tact-giver into rest, which ultimately means stopping the process: the whole configuration (module) stops its work directing the system to the 'safe side'.

So, this obviously shows that the work of both processors and all the activities that are related to further process operation are controlled in the earliest phase of every tact.

This early control, as an internal mechanism for identifying mistakes even in the earliest phase, is supported by a special additional checking program, which periodically checks the complete status of the system. Also, all the inside data, before their entry into the memory, are subject to automatic comparison and correction.

It is clear that this kind of safety concept assumes safety functions of the tact-giver and the comparator, implying that they must be 'fail-safe' designed, i.e. that every mistake on one of the elements of these modules must be reflected in the ultimate instance in the content of the BUS signal.

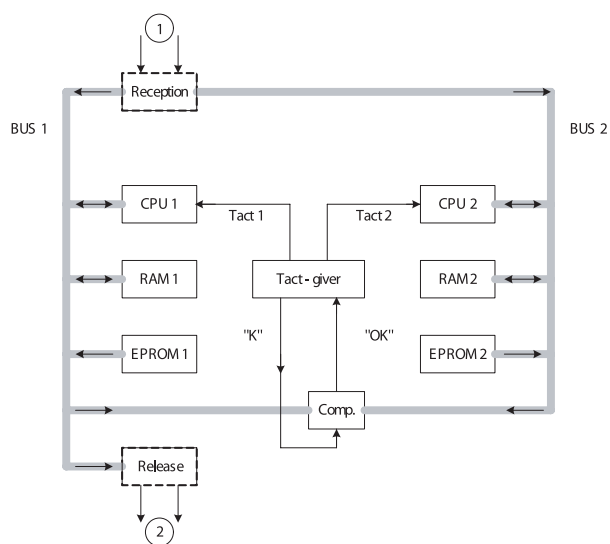

Fig. 1 Basic structure of the two-channel safety microcomputer

## 2. Principles of safety in the railway signalling systems

The signalling systems are not immune from failure and, therefore, due to their specific role, they must be designed and constructed so that even in case of disturbance and failure they do not endanger the safety of the traffic, which implies that they must be signal-safe and technically-safe.

This 'fail-safe' behavior is achieved by implementation of the signalling principles and safety criteria and using highly reliable devices regardless of the technology.

As a defined measure of safety, the international railway organization UIC, i.e. its committee ORE, has defined in its recommendations on the basis of so far experience and the achieved level of technical development 'the mean time between two dangerous failures' - 'MTBF', as a reliability measure in between two

failures. For example, for an electronic signal box this means, respectively:

- That the mean time between two dangerous failures (MTBF) must not be closer than 100 years;
- That the mean time between two failures (MTBF) must not be closer than 4 months (2880 hours).

### 2.1. The purpose and the functioning principle of the signalling/safety devices

Fig. 2 illustrates the role of the system of railway signallization with modalities of implementation of the safety principles.

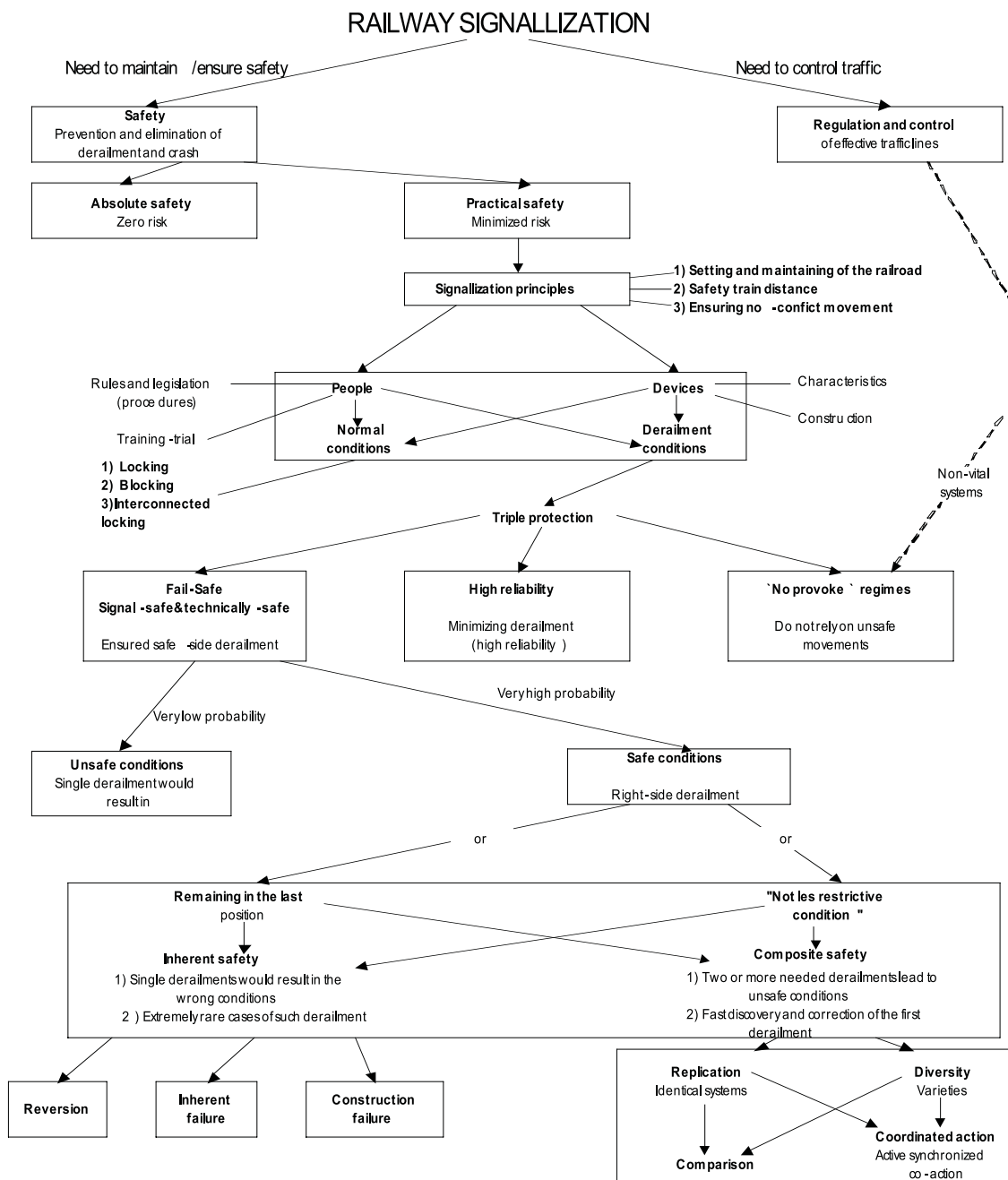

Fig. 2 The role of the railway signallization system with modalities of implementation of the safety principles

Fig. 2 clearly illustrates that the two basic purposes of the railway signallization are:

- control and management of the traffic;
- ensuring safety in railway traffic.

### 3. Conclusion

The issue of achieving complex safety with standardized module solutions has been laid down as a possible concept in this work. The possible applications are in: electronic signal boxes, vital ETCS computers, terminal computers for controlling signals and branches, and as basic elements in transmission of safety data and crypto communication.

In all these possible applications there are considerable differences in the scope of necessary hardware for the basic module, the necessary software in relation to the function, the factor of environment and also the necessary reliability in the safe data transmission.

The new technology implies a close connection between the hardware and the software, where the software controls the hardware safety. The procedures, steps and the sequences of operation are included in the software, more precisely in the program, which is especially important for the safe data transmission.

### References:

- [1] ADAMOVIĆ, Z. BRKIĆ, R.: *The Reliability Engineering*, The Association for Technical Diagnostics of Serbia - TEHDIS, Belgrade, 2004.
- [2] BUSSE, K., FELTEN, F.: *Safe Data Transmission through Airwaves for the First Time in a CBI*, SIGNAL+DRAHT, 4/2005.
- [3] BRKIĆ, R.: *Quality Analysis of Reliability and Safety of a Railway System*, The scientific-professional magazine Technical diagnostics - TEHDIS, Belgrade, 2006.
- [4] BRKIĆ, R.: *Application of New Technology in the Integrated Railway System*, XXIX May Convention of Railway Maintainers of Serbia and Montenegro, Vrnjacka Banja, 2006.

Jan Krmela \*

---

## COMPUTATIONAL MODELLING OF TYRES CONSIDERING OPERATING AND SAFETY REQUIREMENTS

*This contribution deals with the structural concept of tyres considering operating and safety aspects. Results obtained from experimental modelling of tyres considering operating and functional aspects are an essential condition of generation of "correct" computational models of tyres. Achievement of harmony between all requirements on the tyre and resulting demands on safety which would lead, apart from other things, to an increase of the life of the tyre, is a topical issue of computing algorithms in tyre-manufacturing plants.*

### 1. Introduction

The rapid development of automotive industry is evidenced by the production of a large variety of vehicles. New more powerful and more perfect road and off-road cars are placed on the market. Automobile manufacturers try to outstrip competitors by quality and quantity of products, whereby their priority is to meet all operating and safety requirements and, at the same time, to guarantee long life and reliability of the car, which is considered as a comprehensive dynamic system. All this is required in spite of the increasing speed of cars and customer requirements for comfort, ergonomics, etc. Light materials are used to reduce car weight and, consequently, operating costs.

The extensive development of cars and all transportation means cannot manage without predicting loading states by quick estimates. A combination is used of computational modelling as a supporting tool and the classical experimental approach. Computer aids should facilitate designers and development engineers drafting prototypes and models which are used for load tests of individual components as well as of whole automobiles.

Tyres are developed along with cars namely considering their design, material and safety. The reason for this is that tyres as the elements assuring good interaction between car and road must meet critical safety criteria at high speeds (the defect of a tyre on a highway at high speed has to be controllable and must not lead to fatal accidents). This is incidentally also a question of assigning the correct type of a tyre to a car and to its operating conditions (tyres only for road operation, for off-road, combined operation as well as for summer or winter conditions). This is why the use of computational modelling is applied also to the field of tyres (design modification – change of inclination angle of reinforcing fibres, number of reinforcing layers, materials of cords, etc.).

The work of the author over a long period of time is devoted to radial tyres for passenger motor cars and, particularly, to their computational modelling [1, 2].

In order to be able to adopt a comprehensive approach to the state of the art trend of computational modelling, it is necessary to have good knowledge of the function of wheels with tyres, different types of tyres, their design, structure, range of materials, operating conditions, characteristic behaviour at particular modes of loading and knowledge of more details and data. All these can be considered as input parameters absolutely necessary for computational modelling without which present modelling engineers cannot manage.

The present contribution deals with the structural concept of tyres considering operating and safety requirements.

For a comprehensive approach the functions of wheels with tyres are a primary issue.

### 2. Functions of wheels with tyres

The function of wheels with tyres is not only to align a car reliably. As can be seen in more detail from Fig. 1 there are more requirements on tyres. The main operating requirements on car tyres are that car wheels should be as light as possible and, at the same time tough, statically and dynamically balanced.

The main requirements on tyres are, apart from other things, high wear resistance, optimal deformation characteristics, low rolling resistance, high operating life, etc. Wheels with tyres must meet particular functional requirements given by parameters of tyres which affect the running properties of the car, i.e. affect their dynamic behaviour (car manoeuvrability, stability, acceleration, deceleration, driving comfort, etc.).

---

\* Jan Krmela

Department of Transport Means and Diagnostic, Jan Perner Transport Faculty, University of Pardubice, Czech Republic;  
E-mail: Jan.Krmela@upce.cz, Jan2.Krmela@post.cz

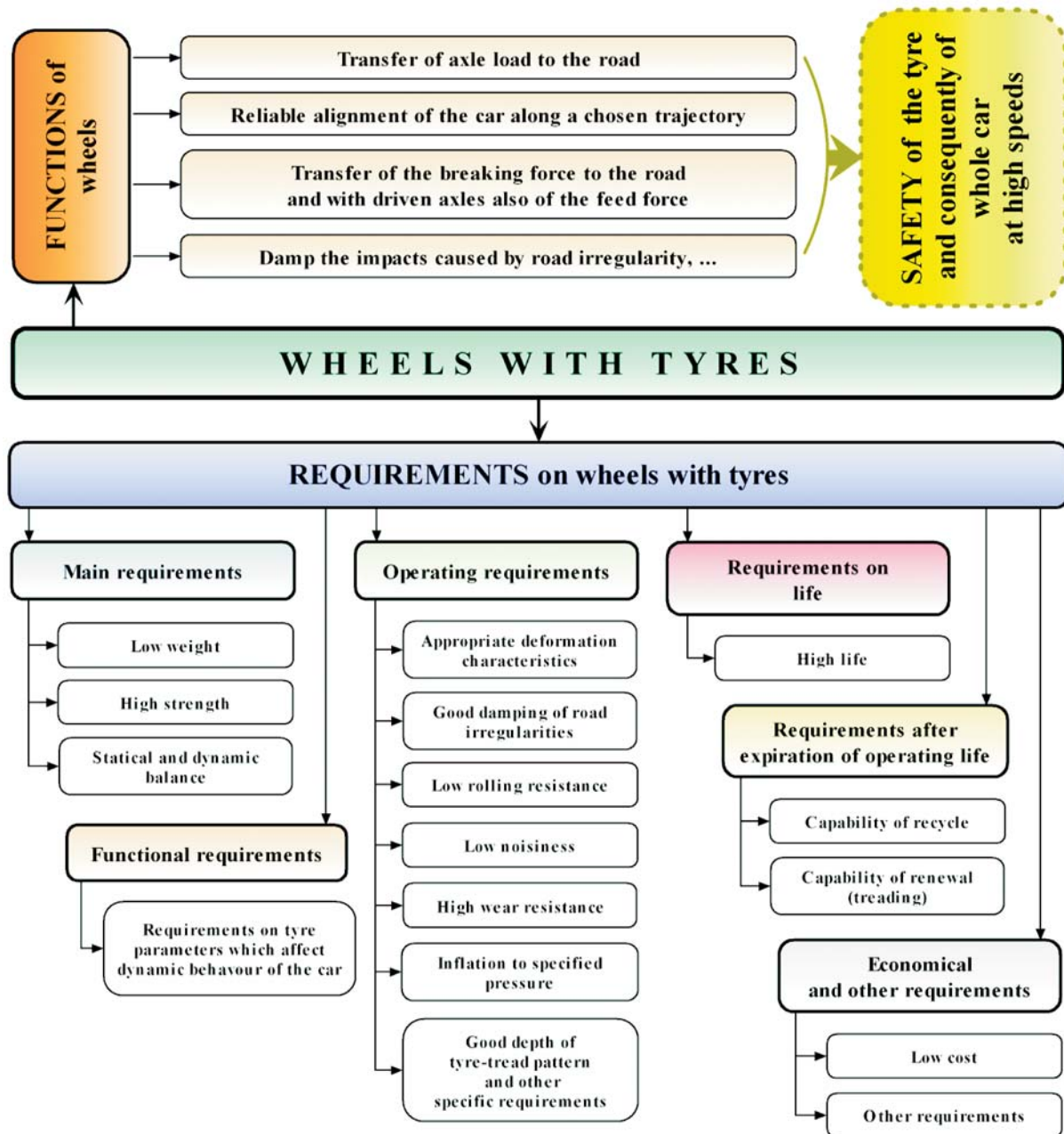

Fig. 1 Functions of wheels with tyres and requirements on them [2]

Further specific requirements on tyres, e.g. vehicles handling material in metalworks close to metallurgical furnaces where tyres are exposed to extremely high temperatures are as well as to sharp objects.

### 3. Definition of a tyre

Tyres as heterogeneous composite bodies can be defined from various viewpoints as shown in Fig. 2. From a geometrical point

of view the tyre is an annulus, from the viewpoint of strength and flexibility it can be considered as a pressure vessel and with respect to the structure of individual parts of the tyre casing and respective different properties a tyre can be considered as a part with anisotropic properties. Furthermore, a tyre can be statically and dynamically loaded, which is given by the actual operating condition.

A specific requirement on tyres is safety at high speeds and the consequential measures aimed at preventing fatal road accidents.

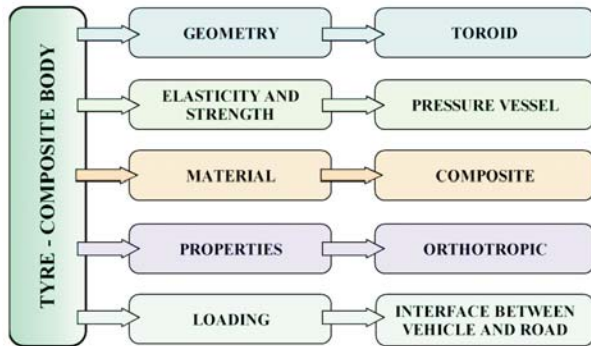

Fig. 2 Definition of tyre from various viewpoints [2]

**4. Tyres for high speeds from the viewpoint of safety**

Tyre safety is passive and active – see Fig. 3. Passive safety depends on the quality of the production of a tyre casing, the applied technology and used materials and in the case of computational modelling also on the accuracy of the performed calculations and appropriate choice of the computing algorithm.

Requirements on active safeness are particularly high running safety on various types of road surfaces, breakdown resistance, speed resistance and high life of materials used for the production of tyres, namely reinforcing materials.

The aim is to avoid fatal road accidents which might be caused by tyre casing defects either by neglecting operating conditions of tyres (depth of tyre tread pattern, tyre inflation pressure, use of inappropriate tyres with a different structure, etc.) or by bad vulcanization during the manufacturing process creating delaminations.

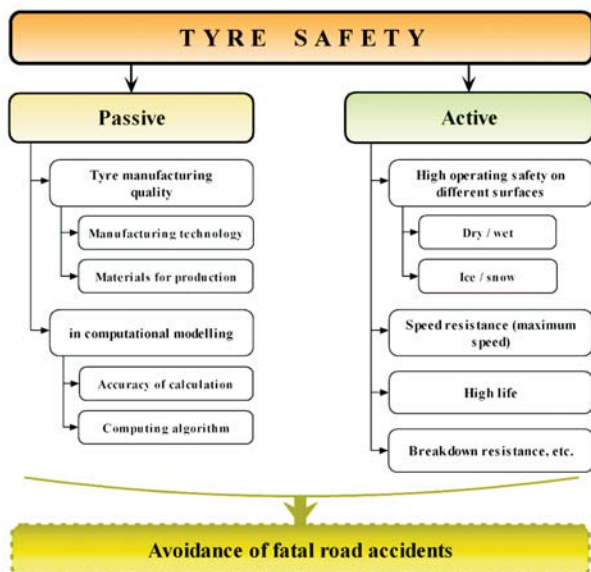

Fig. 3 Viewpoints of tyre safety [2]

For this reason tyres and wheels as a unit are modified from the structural point of view, particularly for special army vehicles where even a sudden drop of pressure does not put an end to the operating capability of the vehicle (system with a central collar providing circular indexing of the casing with respect to the wheel rim).

New features are introduced for high speeds, e.g. electronic systems which warn the drivers in the case a gradual drop of the tyre pressure or adjusting systems for inflation based on the temperature load of the tyre casing. Each manufacturer protects the results of his developments and patents considering them as private “know-how”. Consequently, all new information is only very scarcely available.

The listing of various structural modifications would lie outside the scope of this contribution. Obviously this is an actual topic where the use of modern computational methods is advanced and purposeful.

Tyres are subject to internal and external effects which can more or less cause limit states leading to degradation processes (delamination, etc.).

During the operation of a vehicle combined loading of the tyre occurs both from a mechanical (statical, dynamic) and a temperature point of view (local heating in subzones, global heating in the tyre-tread area permeating into the tyre during breaking). Also this has to be considered in defining tyre safety at high speeds.

**5. Requirements on tyre life**

Tyres must resist during operating to surrounding effects, to negative effects of operation and to other effects, which could lead e.g. to delamination. Resistance to the following effects is considered:

- puncture – capability of tyre to resist puncture by sharp objects
- cut-through – capability of tyre (especially of the tread and sidewall) to resist contact with sharp objects
- breakdown – capability of tyre to resist damage during short-term loading by concentrated forces
- fatigue – capability of tyre to resist material fatigue and defects in consequence of repeated loading cycles
- separation and delamination – capability of structural tyre components to maintain integrity of the system during operation
- humidity – tyre elements must be able to resist degradation by contact with water
- ozone influence – capability of tyre and of its components to resist degradation caused by ozone present in atmosphere
- temperature – tyre components must be able to resist high and low ambient temperatures and also consequences of contact with the road
- chemicals – capability of tyres and their components to resist degradation caused by chemicals (in winter – influence of salt solutions).

Knowledge of the extent of resistance of tyres to various modes of loading and effects of the environment is gained from tests of strength and life - in other words from destructive tests (Fig. 4).

### 6. Tests of tyres for computational models

Computational modelling requires confirmation analyses combined with experiments. This is the reason why it is necessary to run not only tests of tyres as a whole, as shown in Fig. 4, but also tests of individual tyre casing components [3], purposely separated parts etc.

This is how an overview which structural modifications can lead to an increase of the level of safety criteria, increase of resistance, life etc. can be obtained.

Basic statical deformation characteristics of tyres can be obtained from a device called statical adhesion (Fig. 5), which is available to author. The statical adhesion also enables measurement of data from the contact surface under defined conditions, as presented in Fig. 5.

### 7. Computational modelling of tyres

If relevant results are obtained from experimental modelling of whole tyres and individual components and all input data are available, generation of computational models of the tyre casing can proceed [4]. On the basis of the author's long experience the FEM model of an actual radial tyre (Fig. 6) was generated which is "open" to different modes of loading and analyses assuming necessary input data are completed into the calculations.

### 8. Conclusions

This contribution deals only with a specific field which the computing engineer has to be well acquainted with from an operating and safety point of view and from the resulting requirements for tyre resistance. This is the only way how to obtain highly sophisticated computational models of tyres, naturally assuming knowledge of accurate material parameters of all parts of the tyre casing and of the other necessary data such as inputs of road characteristics, load, type of car, etc.

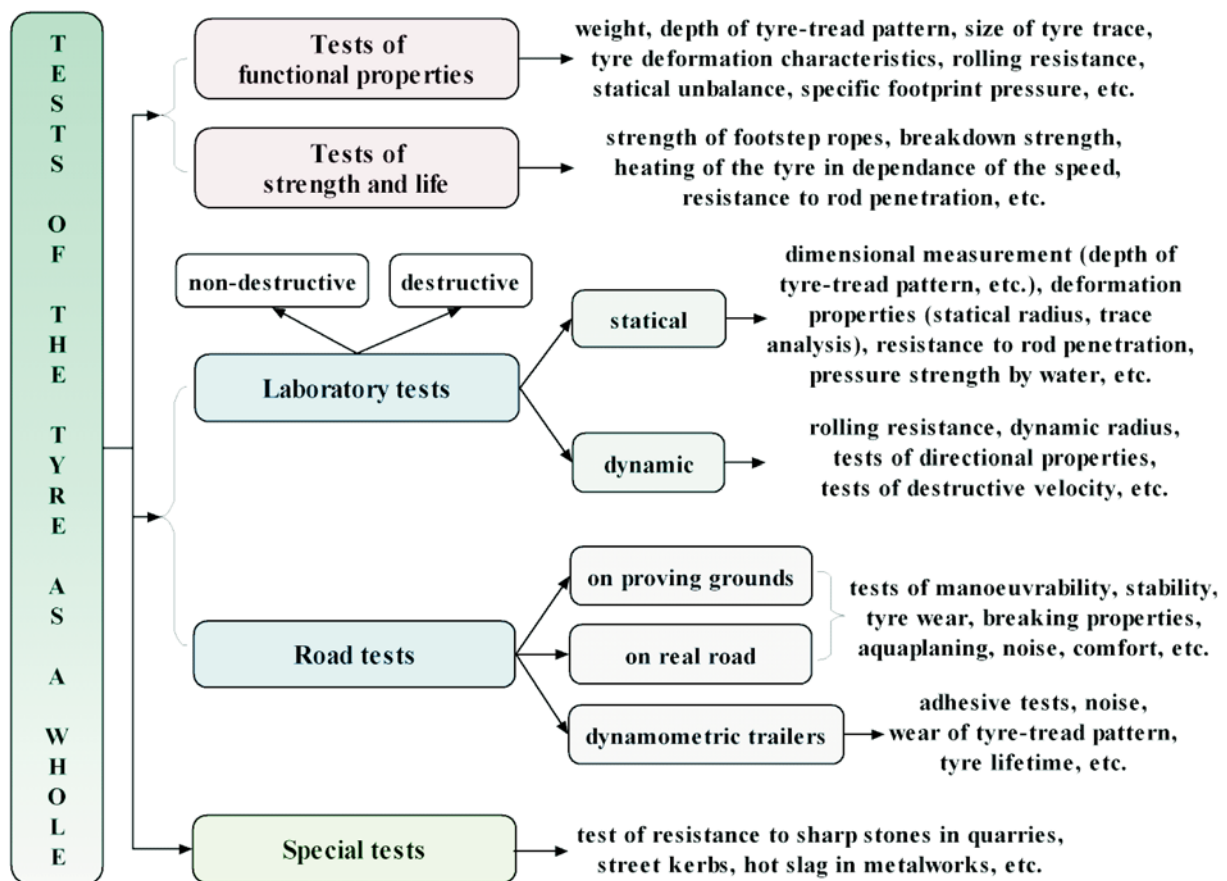

Fig. 4 Tests of the tyre as a whole [1]

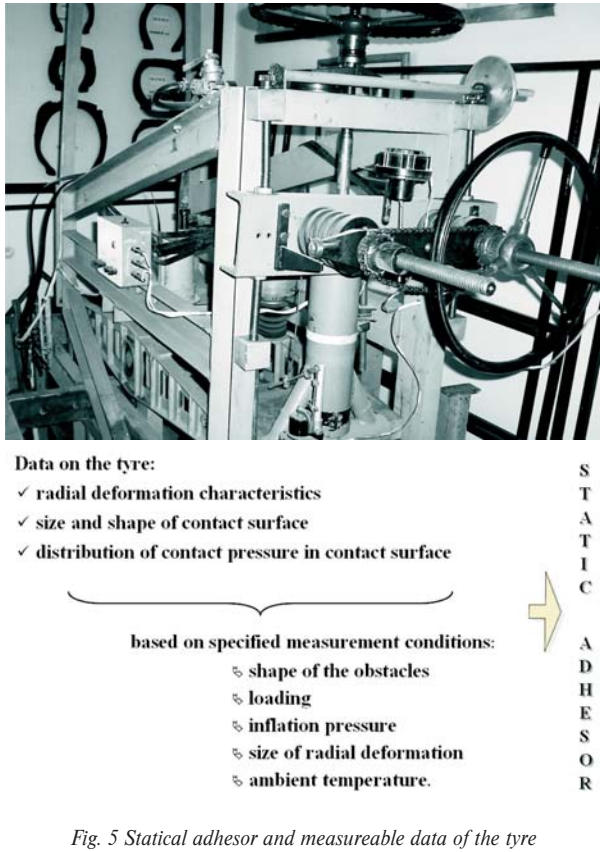

Fig. 5 Static adhesion and measurable data of the tyre

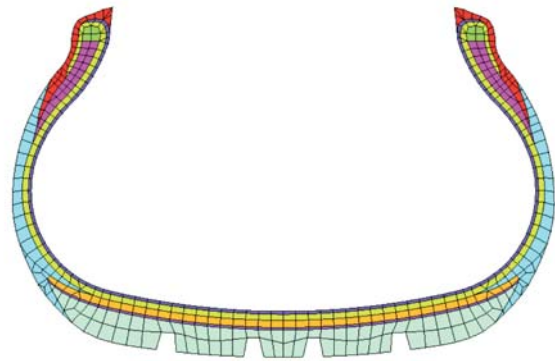

Fig. 6 Computational model "open" to further analyses (cross section)

Approach to the compiling of the computational models of the tyre shown in [2] can be applied also to the other construction types of the tyres, different sizes, etc.

**References**

[1] KRMELA, J.: *Design of the Computational Three-Dimensional Model of the Radial-ply Tyre (in Czech)*, [Dissertation thesis], Ceska Trebova, Jan Perner Transport Faculty, University of Pardubice, Czech Republic, 2004, p. 226

[2] KRMELA, J.: *Systems Approach to the Computational Modelling of Tyres - I. Part (in Czech)*, Monograph, Brno, Czech Republic, 2008, p. 102, ISBN 978-80-7399-365-8, Online: <<http://www.tyre-fem.wz.cz>>

[3] KRMELA, J., PESLOVA, F., HAJDUCHOVA, L.: *Composite with Elastomer's Matrix (in Czech)*, Material Engineering, University of Zilina, 3/2004, pp. 17-24, ISSN 1335-0803.

[4] KRMELA, J.: *The Computational Modelling of Multi-Layer Composites' Materials (in Czech)*, Proc. of conference Dynamic Rigid and Deformable Bodies 2006, Usti nad Labem, Czech Republic, 2006, pp. 103-110, ISBN 80-7044-782-6.

[5] RUSNAKOVA, S. et al.: *Assessment of Espi Technique for Detection of Vibration Behaviour of Composite Laminates*, Proc. of 12th International conference on Problems of Material Engineering, Mechanics and Design, Jasna, Slovakia: 2007, CD-ROM - Full texts of paper, p. 3, ISBN 978-80-969728-0-7.

[6] KRMELA, J., HAJDUCHOVA, L., PESLOVA, F., JANICEK, P.: *Composite Structures Used in Tyre*, Proc. of 22<sup>nd</sup> International Colloquium Advanced Manufacturing and Repair Technologies in Vehicle Industry, Poland, 2005, pp. 15-16, ISBN 80-8070-393-0.

Jarmila Sosedova – Jan Slesinger – Miroslav Bariak \*

## TELEMATICS IN INLAND NAVIGATION

*One of the goals of EU transport policy is the implementation of integrated control systems to control transport processes in all means of transport, including the systems for water transportation. Recent deployment of information and communication technologies on inland waterways brings noticeable impact in security and efficiency of transport. Based on this, the European Council and Parliament issued the directive concerning harmonized River Information Services (RIS) on inland waterways around European Union Member States. Its aim is the harmonized implementation of information and communication systems on the network of European inland waterways.*

### 1. Introduction

The application issue of information, communication and telematic services in transportation including water transport falls into key areas of WHITE PAPER “European transport policy for 2010: time to decide” [KOM(2001)370 dated 12<sup>th</sup> September 2001].

In the past few years the penetration of information services applications on inland waterways raised quickly around EU Member States. Many of these applications have nowadays noticeable impact in security and efficiency of transport processes. The European Commission therefore emphasizes the necessity to negotiate common requirements and technical specifications for this area.

As a result of such negotiations a harmonized system of navigation assistance and an information system covering inland waterways in EU should be established.

Based on mentioned requirements the European Council and Parliament issued the directive 2005/44/EU dated 7<sup>th</sup> September 2005 concerning harmonized River Information Services on inland waterways around European Union [2].

The application of directive fully covers the establishment and operation of River Information Services around all class IV and up waterways in EU Member States which are interconnected together with neighbor states by class IV and up waterways. This directive also covers harbor infrastructure on such waterways.

### 2. The purpose of RIS project implementation

The River Information Services in this case represent harmonized information services supporting inland navigation and transportation processes administration including interconnection to other means of transport. River Information Services concentrate

services for all parties concerned (freighters, shippers, transport operators etc.). Such services deal with actual waterway status information – tactical planning, statistics, inland navigation support, harbor fees, custom services, accident recovery support and other.

The directive forms the framework for deployment and utilization of harmonized River Information Services around European Union with the aim to support inland navigation, enhance transport security, efficiency and environmental friendliness. This framework also covers the issue of interconnection between water transport and other means of transport around Union [2].

Another important part of this directive establishes the outline for negotiation of common requirements and technical specifications in this area. Basic requirements and technical specifications are due to be developed by European Commission taking in account the directives already issued by international organizations (PIANC, CCNR a UNECE). This step should guarantee further continuity of development services for transport process control in other means of transport including the interconnection to maritime transport systems.

In case of River Information Services (RIS) deployment to EU Member States it is very important to guarantee further system interoperability and system application efficiency. Such information system should easily cooperate with information systems already in service in other means of transport at least around European Union countries. Therefore all Member States for purposes of system establishment should:

- provide to RIS users all relevant data concerning navigation and transport planning in inland navigation,
- supply geographical information system maps suitable for inland navigation for all inland waterways class Va and up,
- arrange administration reports reception with required data from communication with vessels for responsible RIS authorities,

\* Jarmila Sosedova, Jan Slesinger, Miroslav Bariak

Department of Water Transport, Faculty of Operation and Economics of Transport and Communications, Zilinská univerzita  
E-mail: Jarmila.Sosedova@fpedas.uniza.sk

- guarantee that the messages for boatmasters are provided as a standard downloadable encrypted messages. Such messages should carry information at least with data necessary for safe navigation. Optionally these messages should also carry additional information concerning ice rung, maximal allowed draft etc.

The local law regulations, rules and directives around all intended Member States concerning such waterways should come in force before 20th October 2007. This step should lead to accordance with global RIS harmonization and EU directives [2].

### 3. The scope of the RIS project

As a result of last research studies in the area of River Information Services around several EU Member States the project IRIS Europe (Implementation of River Information Services in Europe) was issued in late 2005. Its aim is to stimulate activities in field of telematics and intelligent transport systems in inland navigation by implementation of a testing platform of harmonized River Information Systems. This effort should result in early deployment of RIS around EU inland waterways, should lead to elimination of existing barriers and to demarcation of consequential functions and services in Danube and Rhine – Seine regions.

The IRIS Europe project is a part of European program TEN-T (Trans-European Transport Networks) covered by European Commission with the highest investment priority.

The project RIS Europe is maintained and developed by Austria, Slovak Republic, Hungary, Netherlands, Belgium and France state authorities. By affiliation of Bulgaria and Romania to EU also these countries joined the project development. Other European countries – Czech Republic, Serbia and Ukraine are involved as observers to interchange experiences and know-how.

The membership of Slovakia in IRIS Europe project is a natural consequence of successful activity of Slovak government and commercial organizations in projects aimed to define, harmonize and specify River Information Services.

### 4. The structure and goals of RIS project

The project is formally divided into 6 separate sections:

*Section 1:* Infrastructure for tactical traffic situation planning applications

In this field in the area of RIS testing platform installation the Slovak Republic aims to cover establishment of coast-line infrastructure and to cover preparation of support program for ship equipment with necessary devices (installation of AIS base stations on the Slovak part of the river Danube and on borderline parts of the river, establishment of national RIS centre, tracking and tracing electronic data interchange with a group of RIS users) [3].

*Section 2:* Inter-border services of electronic public administration – “e-government”

Slovak Republic should define requirements of administration concerning “e-government” services (for example electronic reporting of dangerous goods transport, electronic reports for custom procedures, statistic data acquisition etc.). This definition should also cover the needs of commercial users. Very important part of this area is the definition of legislation and the definition of the set of service and technical conditions for international RIS data interchange including pilot infrastructure implementation. The goal is to allow national public administration authorities to receive electronic reports of goods being transported in Austria, Slovakia, Hungary and France [4].

*Section 3:* Environmental services testing infrastructure

In this area the Slovak Republic covers the vessel waste management issue and the issues of navigation information interchange with the aim to decrease accidents and to provide disaster recovery solutions.

*Section 4:* Coordination in corridor VII (candidate countries and third-parties), the Rhine – Seine region coordination and Baltic countries coordination – the knowledge transfer

Activities in this area are covered by project partners in Austria and The Netherlands.

*Section 5:* Open issues in harmonization and standardization of RIS

The Slovak Republic based on requirements defined in RIS directive covers the harmonization and standardization issues in the area of River Information Services. Its application aims to the field of Intelligent Transport Systems, where the Slovak Republic defines the framework for cooperation of interconnected systems in transport services. The solution includes also risk analysis for passenger and crew members, identification of services and functions for crew and passengers safety in inland navigation including law and technical regulations in this area [3] and [5].

*Section 6:* The project control

Last section deals with control and supervision activities, knowledge transfer and application including national and international activities in water transport not covered directly by this project and the initiatives in the area of off-shore maritime navigation.

### 4. Conclusion

The Slovak Republic joined the project preparation and planning in accordance with its national policy directive (“Dopravná politika Slovenskej republiky do roku 2015” – Slovak government decree No. 445 issued on 8 June 2005) with the aim to fulfill its commitments from RIS directive (2005/44/EU). The intention of the RIS directive places liability for local governmental institutions (in case of Slovakia responsible person is The Ministry of Transport, Post and Telecommunication of the Slovak Republic) to provide expert capacity and to control the process of project financing to reach the demarked targets.

During passed few years the main activity of Slovakia in the River Information Services project concentrated on the COMPRIS (Consortium Operational Management River Information Services) project. Local national institutions mainly involved in this project were Transport Research Institute, Inc. Zilina, a branch for development in water transport in Bratislava, State Navigation Administration Bratislava, Slovensky vodohospodarsky podnik, the company OZ Bratislava Ltd. in the area of digital maps for inland navigation and KIOS, Ltd. Piestany in the area of software application development and electronic data interchange with public admin-

istration authorities. The company Slovenská plavba a prístavy, a.s. Bratislava, which provided vessels for the COMPRIS project testing and assisted in development of the messaging system for boatmasters, participated in this project as a cooperator. The institution Slovenský hydrometeorologický ústav provided necessary data concerning water-level stage and meteo-data [1].

Total project cost estimation value figures 4.146 million EUR. The project is financed from the European Union TEN-T program up to 50% of its costs for solution and test projects.

## References

- [1] SOSEDOVA, J. et al.: *Project VEGA MS SR 1/3831/06 - Transport - Juridical Conditions of Inland Shipping and their Economic Consequences for Carriers after the Entrance of the Slovak Republic to the European Union*
- [2] DIRECTIVE 2005/44/EC OF THE EUROPEAN PARLIAMENT AND OF THE COUNCIL of 7 September 2005 on harmonized river information services (RIS) on inland waterways in the Community, Official Journal L 255, 30/09/2005 P. 0152 - 0159
- [3] COMMISSION REGULATION (EC) No 414/2007 of 13 March 2007 concerning the technical guidelines for the planning, implementation and operational use of river information services (RIS) referred to in Article 5 of Directive 2005/44/EC of the European Parliament and of the Council on harmonized river information services (RIS) on inland waterways in the Community, O.J. L 105 of 23 April 2007, pp. 1-34
- [4] COMMISSION REGULATION (EC) No 415/2007 of 13 March 2007 concerning the technical specifications for vessel tracking and tracing systems referred to in Article 5 of Directive 2005/44/EC of the European Parliament and of the Council on harmonized river information services (RIS) on inland waterways in the Community, O.J. L 105 of 23 April 2007, pp. 35-87
- [5] COMMISSION REGULATION (EC) No 416/2007 of 22 March 2007 concerning the technical specifications for Notices to Skip-pers as referred to in Article 5 of Directive 2005/44/EC of the European Parliament and of the Council on harmonized river information services (RIS) on inland waterways in the Community, O.J. L 105 of 23 April 2007, pp. 88-253
- [6] [www.iris-europe.net](http://www.iris-europe.net)
- [7] [www.iris-europe.sk](http://www.iris-europe.sk)
- [8] [www.telecom.gov.sk](http://www.telecom.gov.sk)

Ivana Olivkova \*

## PASSENGER INFORMATION SYSTEMS IN PUBLIC TRANSPORT

The article deals with establishment of passenger information systems which are comprehensive and not limited to one or more individual operators or transport modes. The systems should be multi-lingual, disabled adapted, both inside and outside interchanges, and combine static (i.e. timetable) and dynamic data on both public and private transport services.

### 1. Introduction

Passenger information systems in transit applications refer to the use of technology to provide travel information to passengers in order to assist their trip-making or route choice decisions either prior to departure or en route. The information provided may vary from static route, schedule and fare information to real-time vehicle location and/or estimated arrival time. Real-time information can be offered to passengers when the passenger information system is used in conjunction with GPS systems. Furthermore, passenger information might be disseminated through the use of transit operations software such as itinerary planning systems.

Passenger information is generally expected to improve the quality of transit service by improving the passenger experience. Passenger information may grant passengers a better sense of control over their trip-making decisions and/or enable them to take action to minimize their waiting times at stops, plan their transfer connections and thus reduce their overall travel time.

### 2. Categories of information systems in public transport

Information systems may be provided in three categories (Fig. 1):

- Pre-trip passenger information systems
- In-terminal/wayside information systems
- In-vehicle information systems

Various factors affect passenger trip-making decisions, including service characteristics such as frequency and coverage. Different types of information (e.g. static or real-time) and different methods for accessing that information (e.g. via the internet at home or in vehicle announcements) will likely have different effects on how passengers use different types of service (e.g. high frequency and low frequency). There is a wide variety of passenger informa-

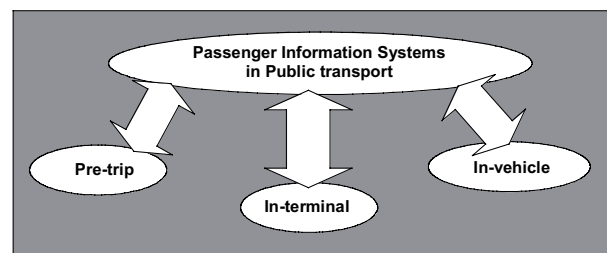

Fig. 1 Categories of passenger information systems

tion systems that are designed to influence specific passenger behaviors and decisions. Below, each of the categories of passenger information systems listed above is discussed.

### 3. Pre-Trip Passenger Information Systems

Pre-trip passenger information systems imparts to the user information relevant to the choices that are made prior to departure. These pre-trip decisions include choice of mode, route and departure time, thus enabling passengers to choose a course of action that best serves their trip purpose.

There are two types of pre-trip passenger information:

- General Service Information,
- Itinerary Planning.

General Service Information systems offer static information, such as route, schedule and fare information. This information can be accessed by phone or by consulting maps and timetables that are posted on vehicles, at stops, or on the Internet.

Itinerary planning systems allow passengers to consider a variety of factors such as travel time, walking distance, cost, and number

\* Ivana Olivkova

Institut of Transport, Faculty of Civil Engineering, Technical University of Ostrava, Ostrava - Poruba, Czech Republic,  
E-mail: ivana.olivkova@vsb.cz

of transfers. With these criteria in mind, the passenger may choose from the alternative trip plans that connect their origin to their destination.

Passenger response to pre-trip information has been hypothesized and modeled in the literature. It is important to distinguish between low frequency, regular services (e.g. suburban and off-peak urban routes) and high frequency, irregular services (e.g. urban routes) when considering transit passenger route choice. It is generally assumed that, for low frequency services, passengers choose both the stop and the trip (i.e. scheduled departure time) before the trip begins. With high frequency services, passengers are assumed to choose only the stop prior to starting the trip.

The choice of various stops on routes that serve the passenger's destination can be modeled according to random utility theory, where each candidate stop in the choice set has some utility value that is a function of the stop's attributes. Therefore, various types of pre-trip information (e.g. schedules, estimated arrival times) might contribute to the perceived utility of a stop and have a significant impact on passenger pre-trip stop choice. For high frequency services, it is assumed that passengers develop, prior to departure, a choice set of candidate routes that serve the origin stop. Choice of the actual trip from the set of alternative routes is assumed to take place en-route. However, pre-trip static and/or real-time information can play an important role in the passenger's consideration of possible routes.

**4. In-Terminal Information Systems**

Passenger information systems that provide information to passengers while they wait at stops are designed to provide waiting customers with current information regarding delays, estimated arrival times and other real-time vehicle performance data.

The dynamic stop information system (DIS) makes it possible to inform visually and acoustically the passengers in the public transportation about the actual situation on the particular stop (Fig. 2). The system compares the time table with the actual traffic situation monitored by the following of the vehicles position with

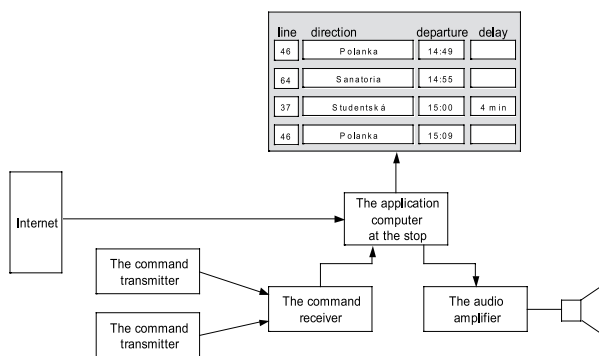

Fig. 2 The dynamic stop information system

the help of the satellite navigation system GPS. The data about the bus location are transmitted from the vehicles by means of the radio communication adapter with the GSM /GPRS modulus into the central traffic information centre (CETIS). In the CETIS the data are processed and they can be completed by the time table. The information about time deviations of the buses from the time table is conveyed in the real-time with the help of the Internet (Intranet) to the application computer at the stop or at the station. The passengers are in a position to watch the information about the actual traffic situation on the large area colour display panel. The visually impaired and handicapped persons outfitted by the command transmitter can solicit the information in the acoustic form [4].

The information provided at transit stops may or may not influence passenger route choice. For low frequency, regular services, it is assumed that passengers have already chosen a stop and a trip prior to departure. Therefore, in the case of low frequency services, in-terminal/wayside information may be used to ease customer frustration and impatience during delays. However, in-terminal/wayside information can influence the passenger's en-route decision-making behavior in the case of high frequency services. For example, if more than one route serves the origin stop, the passenger may choose from among a set of approaching vehicles that serve the destination.

According to random utility theory, each approaching candidate trip has some utility associated with it, which might be a function of passenger information [3]. The utility of an approaching trip in the choice set as a function of:

- Waiting time (the difference between the estimated arrival time of a trip and the estimated arrival time of the base trip), provided by the information system
- In-vehicle travel time
- Transfer time to the connecting trip
- Number of passengers
- On-board comfort (i.e. level of crowding on-board between the origin and destination stops)
- Time already spent at the stop

**5. In-Vehicle Information Systems**

In-vehicle information systems use public address systems, either automated or performed by the operator, variable message signs and other on-board systems to communicate information to the passengers. In-vehicle information might include the name of the next stop, transfer opportunities at the stop, points of interest near the stop, and other information relating to upcoming stops. There is less opportunity to influence a passenger's route choice decision-making on a transit vehicle, since the passenger has already chosen a stop at which to board, the vehicle (or trip) and, presumably, a destination. However, some real-time information, such as the whereabouts of connecting vehicles at downstream stops might be conveyed using in-vehicle information systems. The user, then, may update the destination stop choice or begin planning the next leg of the trip based on the prevailing connection prospects.

Like the other information systems, the provision of real-time information regarding connecting routes depends on the GPS system in place [2].

Components of in-vehicle information systems [4] - Fig. 3:

- on-board computer and control unit
- exterior signs
- interior information signs
- digital acoustic annunciator

On-board computer and control unit with back lighted keyboard and data record on memory card are determined for controlling of all peripheries in public transport vehicles as part of control and passenger information system in the required configuration: exterior and interior signs, digital acoustic unit, ticketing system, switches and traffic lights setup and GPS location. The construction solution and software enable its using both for manual operation mode and mode with automatical next stop switching, autonomous vehicle location by means of GPS and time table scanning [2].

Exterior and interior information signs indicated line number, destination, real time, tariff zone, duty announcement and other information. Digital acoustic annunciator provides acoustic infor-

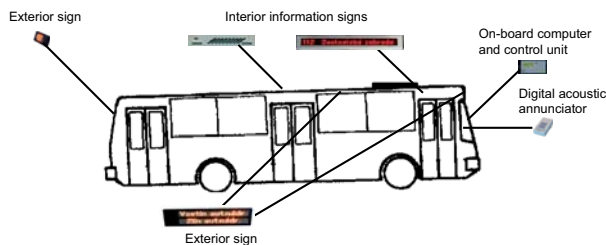

Fig. 3 Components of in-vehicle information systems

mation parallelly up to three independent channels for passengers inside the vehicle, outside the vehicle and driver.

In-vehicle traveler information systems, however, may influence the behavior of passengers aboard the bus. For example, the announcement of a stop may prompt passengers expecting to alight at the stop, especially those not familiar with the system, to begin the approach to the exit doors. If this is the case, the time required to discharge all passengers at the stop may be reduced with the provision of in-vehicle information. Reduced alighting time may lead to a reduction in total dwell time at the stop, and thus affect the progression of the vehicle from stop to stop along its route.

Real-time Information makes use of GPS data to provide current vehicle performance information to users. Performance data might be used to provide either the current locations of transit vehicles or the estimated arrival times of vehicles at stops along the route. The fourth type of pre-trip information is Multimodal Traveler Information, which provides real-time and/or static traffic and transit information. Multimodal information requires transport telematics technologies that measure and estimate the current state of the traffic network as well as transit-specific technologies that provide transit information.

## 6. Conclusions

With increasing demands on the transport network, systems providing accurate, reliable and timely dynamic information to passengers are becoming increasingly important. Many public authorities wish to promote the use of public transport as a viable alternative to the private car. To travel door to door using public transport means passengers must, on occasion, use several modes. This increases potential uncertainty about the journey and interchanges. Real time information can reduce this uncertainty and can promote public transport.

## References:

- [1] PRIBYL, P.: *Intelligent Transport Systems and Transport Telematics II.*, Vydavatelstvi CVUT Praha, 2007.
- [2] OLIVKOVA, I.: *Information Systems in Public Transport*, VSB-TU Ostrava, 2004.
- [3] KRIVDA, V., OLIVKOVA, I., FRIC, J.: *Transport Telematics - part I.*, VSB-TU Ostrava, 2004.
- [4] NUZZOLO, A., RUSSO, F., CRISSALI, U.: *Dynamic Schedule-Based Assignment Models for Public Transport Networks*, Submitted to Springer-Verlag, 2005.
- [5] <http://www.apex.cz>.

Tatiana Olejnikova \*

## TWO AND THREE-REVOLUTION CYCLICAL SURFACES

The creation of two-revolution and three-revolution cyclical surfaces is presented in the paper. Classification and vector equations of the surfaces are given. The surfaces are created by translation of the circle along the curves and its centre is on the curve. The curves are created by revolution of a point about any edge of the trihedron of the previous curve and this trihedron moves simultaneously along this curve. All specific forms of surfaces are illustrated in figures visualized in Maple.

### 1. Introduction

The point  $S_1$  revolves about the coordinate axis  $z$  with angular velocity  $w_1$  in the distance  $d_1$  from the origin of the coordinate system  $(O, x, y, z)$ . For every value of the angle  $w_1$  there exists only one position of the point  $R_1$  and the trajectory of this point  $R_1$  is the curve  $k_1$  (circle). The trihedron  $(R_1, t_1, n_1, b_1)$  defined in every point  $R_1 \in k_1$  is determined by tangent, principal normal and binormal of the curve  $k_1$ . The point  $S_2$  revolves at an angular velocity  $w_2$  about any axis of the coordinate system, which is identical with the trihedron  $(R_1, t_1, n_1, b_1)$  of the curve  $k_1$ , in the distance  $d_2$  from the origin of this coordinate system which is moving simultaneously along the curve  $k_1$ . For every value of the angle  $w_2$  there exists only one position of the point  $R_2$ . The trajectory of this point  $R_2$  is the curve  $k_2^g$ , where  $g = t, n, b$ . The trihedron  $(R_2, t_2, n_2, b_2)$  in every point  $R_2 \in k_2^g$  is determined by the tangent, principal normal and binormal of the curve  $k_2^g$ . The point  $S_3$  revolves about any axis of the coordinate system identical with the trihedron  $(R_2, t_2, n_2, b_2)$  of the curve  $k_2^g$  at an angular velocity  $w_3$  in the distance  $d_3$  from the origin of this coordinate system which is moving simultaneously along the curve  $k_2^g$ . For every value of the angle  $w_3$  there exists only one position of the point  $R_3$ . The trajectory of the point  $R_3$  is the curve  $k_3^{gh}$ , where  $g, h = t, n, b$ . The trihedron  $(R_3, t_3, n_3, b_3)$  in every point  $R_3 \in k_3^{gh}$  is determined by the tangent, principal normal and binormal of the curve  $k_3^{gh}$ .

The surface of the type  $P_1(u, v)$  is created by translation of the circle  $c_1 = (R_1, r_1)$  along the curve  $k_1$ , the surface of the type  $P_2^g(u, v)$  is created by translation of the circle  $c_2 = (R_2, r_2)$  along the curve  $k_2^g$  and the surface of the type  $P_3^{gh}(u, v)$  is created by translation of the circle  $c_3 = (R_3, r_3)$  along the curve  $k_3^{gh}$ . The index  $g = t, n, b$  determines that the point  $S_2$  revolves about the tangent  $t_1$ , or principal normal  $n_1$  or binormal  $b_1$  of the curve  $k_1$  and the index  $h = t, n, g$  determines that the point  $S_3$  revolves about tangent  $t_2$ , principal normal  $n_2$  or binormal  $b_2$  of the curve  $k_2^g$ .

### 2. Vector functions of the curves $k_1, k_2^g, k_3^{gh}$

Let the curve  $k_1$  be a circle created by revolution of the point  $S_1 = S_1(d_1, 0, 0, 1)$  about the axis  $z$  of the coordinate system  $(O, x, y, z)$  at an angular velocity  $w_1 = v$  and  $k_1$  is determined by the vector function

$$r_1(v) = (x_{k_1}(v), y_{k_1}(v), z_{k_1}(v), 1) = S_1 \cdot T_{z_1}(w_1) = (d_1 \cos v, s_1 q_1 \sin v, 0, 1), v \in (0, 2\pi). \tag{1}$$

The matrix  $T_{z_1}(w_1)$  represents the revolution of the point  $S_1$  about the coordinate axis  $z$  given by (5) (3<sup>rd</sup> matrix for  $i = 1$ ), where the parameter  $q_1 = \pm 1$  determines the right-turned or left-turned revolution movement of the point (Fig. 1,  $i = 1, j = z$ ) [3]. We will define the trihedron  $(R_1, t_1, n_1, b_1)$  of the curve  $k_1$  in every point  $R_1 \in k_1$  by the tangent  $t_1(v)$ , principal normal  $n_1(v)$  and by binormal  $b_1$  with their unit vectors  $t_i(v), n_i(v), b_i(v)$  by equations (2), (3), (4) for  $i = 1, v \in (0, 2\pi)$

$$t_i(v) = (a_{ii}, b_{ii}, c_{ii}) = \frac{1}{h_i} \frac{dr_i}{dv} = \frac{1}{h_i} \left( \frac{dx_{ki}(v)}{dv}, \frac{dy_{ki}(v)}{dv}, \frac{dz_{ki}(v)}{dv} \right), h_i = \left| \frac{dr_i}{dv} \right| \tag{2}$$

$$n_i(v) = (a_{ni}, b_{ni}, c_{ni}) = \frac{1}{h_{2i}} \frac{d^2 r_i}{dv^2} = \frac{1}{h_{2i}} \left( \frac{d^2 x_{ki}(v)}{dv^2}, \frac{d^2 y_{ki}(v)}{dv^2}, \frac{d^2 z_{ki}(v)}{dv^2} \right), h_{2i} = \left| \frac{d^2 r_i}{dv^2} \right| \tag{3}$$

$$b_i = \frac{1}{h_{3i}} (t_i(v) \times n_i(v)), h_{3i} = |t_i(v) \times n_i(v)|. \tag{4}$$

The curve  $k_2^g$  is created by revolution of the point  $S_2$  in the distance  $d_2$  from the origin of the coordinate system  $(O, x, y, z)$  about any coordinate axis  $x, y,$  or  $z$  through the angle  $w_2$  into the point  $S_2'$  (Fig. 1,  $i = 2$  for  $, j = x, y, z$ ). Angular velocity  $w_2 = m_1 v$

\* Tatiana Olejnikova

Institute of Technology, Economics and Management in Civil Engineering, Civil Engineering Faculty, Technical University of Kosice, Slovakia, E-mail: tatiana.olejnikova@tuke.sk

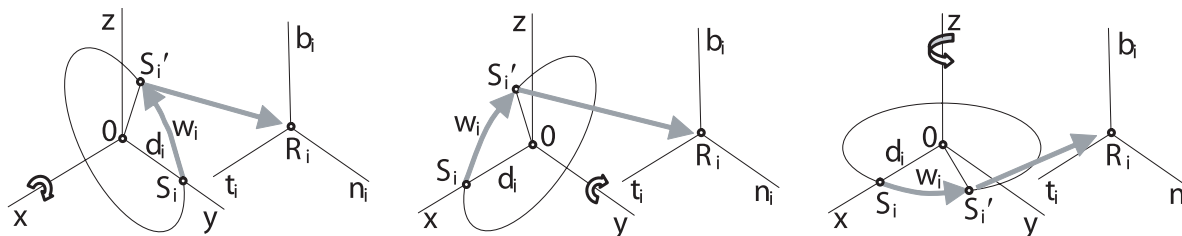

Fig. 1 Revolution of the point about axes x, y, z

of the point  $S_2$  is  $m_1$ -multiple of angular velocity  $w_1 = v$  of the point  $S_1$ . The point  $S'_2$  is transformed into the point  $R_2$  in the coordinate system  $(R_1, t_1, n_1, b_1)$ . If we create a surface of the type  $P_2^g(u, v)$ , where  $g = t$  (or  $g = n$ , or  $g = b$ ), we will revolve the point  $S_2$  about the axis  $j = x$ , or  $j = y$ , or  $j = z$ . The revolution of the point  $S_2$  is represented by a matrix  $T_{j2}(w_2)$ ,  $j = x, y, z$  in (5), where the parameter  $q_2 = \pm 1$  determines the right-turned or left-turned revolution and the transformation of the point  $S'_2$  into the point  $R_2$  is represented by a matrix  $M_2(w_2)$  given by (5) [4]. The point  $S_2$  will be situated always on any coordinate axis  $x, y, z$ .

$$\begin{aligned}
 T_{xi}(w_i) &= \begin{pmatrix} 1 & 0 & 0 & 0 \\ 0 & \cos w_i & q_i \sin w_i & 0 \\ 0 & -q_i \sin w_i & \cos w_i & 0 \\ 0 & 0 & 0 & 1 \end{pmatrix}, \\
 T_{yi}(w_i) &= \begin{pmatrix} \cos w_i & 0 & q_i \sin w_i & 0 \\ 0 & 1 & 0 & 0 \\ -q_i \sin w_i & 0 & \cos w_i & 0 \\ 0 & 0 & 0 & 1 \end{pmatrix}, \\
 T_{zi}(w_i) &= \begin{pmatrix} \cos w_i & q_i \sin w_i & 0 & 0 \\ -q_i \sin w_i & \cos w_i & 0 & 0 \\ 0 & 0 & 1 & 0 \\ 0 & 0 & 0 & 1 \end{pmatrix}, \\
 M_i(w_i) &= \begin{pmatrix} a_i & b_i & c_i & 0 \\ a_{ni} & b_{ni} & c_{ni} & 0 \\ a_{bi} & b_{bi} & c_{bi} & 0 \\ 0 & 0 & 0 & 1 \end{pmatrix}.
 \end{aligned}
 \tag{5}$$

The elements of the matrix  $M_1(w_1)$  in (5) are the coordinates of unit vectors  $t_i(v), n_i(v), b_i(v)$  of tangent  $t_i$ , principal normal  $n_i$  and binormal  $b_i$  in trihedron  $(R_i, t_i, n_i, b_i)$ ,  $i = 1, 2, 3$ . Then the vector function of the curve  $k_i^g$  is

$$\begin{aligned}
 r_2(v) &= (x_{k_2}(v), y_{k_2}(v), z_{k_2}(v), 1) = S_1 \cdot T_{z1}(w_1) + \\
 &+ S_2 \cdot T_{j2}(w_2) \cdot M_2(w_2), \quad j = x, y, z.
 \end{aligned}
 \tag{6}$$

and  $S_2 = S_2(d_2, 0, 0, 1)$  or  $S_2 = S_2(0, 0, d_2, 1)$ .

The trihedron  $(R_2, t_2, n_2, b_2)$  is determined in every point  $R_2 \in k_2^g$  by the tangent  $t_2$ , principal normal  $n_2$  and binormal  $b_2$  with the unit vectors  $t_2(v), n_2(v), b_2(v)$  expressed by equations (2), (3), (4) for  $i = 2$ .

The curve  $k_3^{gh}$  is created by revolution of the point  $R_3$  in the distance  $d_3$  from the origin of the coordinate system  $(O, x, y, z)$  about any coordinate axis  $x, y$ , or  $z$  through the angle  $w_3$  into the point  $S'_3$  (Fig. 2,  $i = 3$  for,  $j = x, y, z$ ). Angular velocity  $w_3 = m_2 w_2 = m_2 m_1 v$  of the point  $S_3$  is  $m_2$ -multiple of angular velocity  $w_2 = m_1 v$  of the point  $S_2$ . The point  $S'_3$  is transformed into the point  $R_3$  in the coordinate system  $(R_2, t_2, n_2, b_2)$ . If we create the surface of type  $P_3^h(u, v)$ , where  $h = t$  (or  $h = n$ , or  $h = b$ ), we will revolve the point  $S_3$  about the axis  $j = x$ , or  $j = y$ , or  $j = z$ . The revolution of the point  $S_3$  is represented by a matrix  $T_{j3}(w_3)$ ,  $j = x, y, z$ , where the parameter  $q_3 = \pm 1$  determines the right-turned or left-turned revolution and transformation of the point  $S'_3$  into the point  $R_3$  is represented by the matrix  $M_3(w_3)$  by equations (5) [4]. The point  $S_3$  will always be situated on any coordinate axis  $x, y$ , or  $z$ .

Then the vector function of the curve  $k_3^{gh}$  for  $j = x, y, z$  is

$$\begin{aligned}
 r_3(v) &= (x_{k_3}(v), y_{k_3}(v), z_{k_3}(v), 1) = S_1 \cdot T_{z1}(w_1) + \\
 &+ S_2 \cdot T_{j2}(w_2) \cdot M_2(w_2) + S_3 \cdot T_{j3}(w_3) \cdot M_3(w_3), \\
 j &= x, y, z.
 \end{aligned}
 \tag{7}$$

The trihedron  $(R_3, t_3, n_3, b_3)$  in every point  $R_3 \in k_3^{gh}$  is determined by the tangent  $t_3$ , principal normal  $n_3$  and binormal  $b_3$  with the unit vectors  $t_3(v), n_3(v), b_3(v)$  by equations (2), (3), (4) for  $i = 3$ .

In Fig. 2 there is displayed a revolution of the point  $S_1$  about the coordinate axis  $z$  through the angle  $w_1$  into the point  $R_1$ , where its revolutionary movement creates the curve  $k_1$ , revolution of the point  $S_2$  about the coordinate axis  $z$  through the angle  $w_2$  into the point  $S'_2$  and its transformation into the point  $R_2$ , where its revolutionary movement creates the curve  $k_2^g$ , revolution of the point  $S_3$  about the coordinate axis  $z$  through the angle  $w_3$  into the point  $S'_3$  and its transformation into the point  $R_3$ , where its revolutionary movement creates the curve  $k_3^{gh}$ . In the points  $R_1, R_2, R_3$  there are displayed trihedrons  $(R_1, t_1, n_1, b_1), (R_2, t_2, n_2, b_2), (R_3, t_3, n_3, b_3)$ .

In Fig. 3 there are displayed for illustration only three combinations of the curves  $k_1, k_2^t, k_3^{tt}, k_1, k_2^n, k_3^{nn}$  and  $k_1, k_2^b, k_3^{bb}$ .

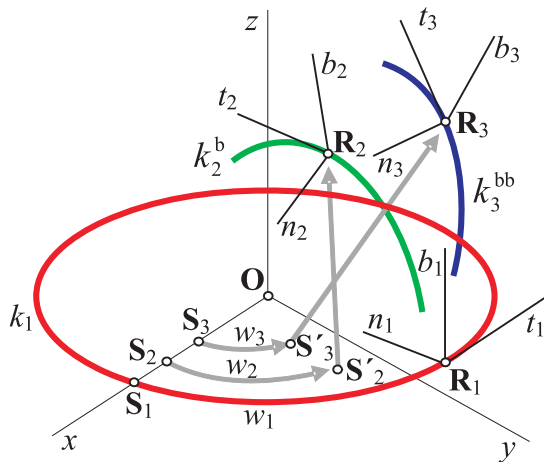

Fig. 2 Creation the curves  $k_1, k_2^b, k_3^{gh}$  and their trihedrons

The two-revolution cyclical surface of the type  $P_2^g(u, v)$  is created by translation of the circle  $c_2 = (R_2, r_2)$  along the curve  $k_2^g$  at an angular velocity  $w_2 = m_1 v$ , where the circle is always in the plane  $(n_2, b_2)$  if the index  $g = t$ , or in the plane  $(t_2, b_2)$  if  $g = n$ , or in the plane  $(t_2, n_2)$  if  $g = b$  and its centre is the point  $R_2 \in k_2^g$ . We will create it so that the circle  $c_{02}$  determined by the vector function  $c_{02}(u) = (0, r_2 \cos u, r_2 \sin u, 1)$  if  $g = t$ , or  $c_{02}(u) = (r_2 \cos u, 0, r_2 \sin u, 1)$  if  $g = n$ , or  $c_{02}(u) = (r_2 \cos u, r_2 \sin u, 0, 1)$  if  $g = b$  we will transform into the circle  $c_2$  in the coordinate system  $(R_2, t_2, n_2, b_2)$  using the matrix  $M_2(w_2)$  by equations (5) (Fig. 4). The vector function of the cyclical surface of the type  $P_2^g(u, v)$  is

$$P_2^g(u, v) = r_2(v) + c_{02}(u) \cdot M_2(w_2),$$

$$u \in (0, 2\pi), v \in (0, 2\pi). \tag{9}$$

where  $r_2(v)$  is the vector function of the curve  $k_2^g$  determined by (6).

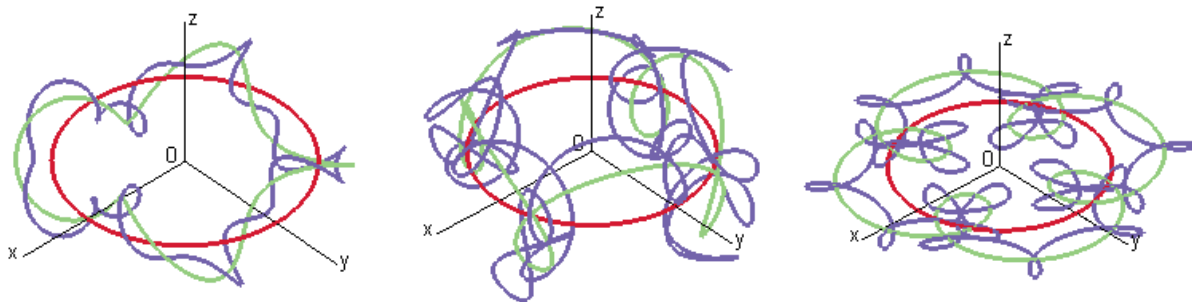

Fig. 3 Combinations of the curves  $k_1, k_2^t, k_3^{tt}, k_1^n, k_2^n, k_3^{nn}$  and  $k_1^b, k_2^b, k_3^{bb}$ .

### 3. Vector functions of cyclical surfaces of the type $P_1(u, v), P_2^g(u, v), P_3^{gh}(u, v)$

The cyclical surface of the type  $P_1(u, v)$  is created by translation of the circle  $c_1 = (R_1, r_1)$  in the plane  $(n_1, b_1)$  along the curve  $k_1$  at an angular velocity  $w_1 = v$ . We will create it so that the circle  $c_{01}$  determined by the vector function  $c_{01}(u) = (0, r_1 \cos u, r_1 \sin u, 1)$  will be transformed into the circle  $c_1$  in the coordinate system  $(R_1, t_1, n_1, b_1)$  using the matrix  $M_1(w_1)$  expressed by equations (5) (Fig. 4).

The vector function of the cyclical surface of the type  $P_1(u, v)$  is

$$P_1(u, v) = r_1(v) + c_{01}(u) \cdot M_1(w_1),$$

$$u \in (0, 2\pi), v \in (0, 2\pi). \tag{8}$$

where  $r_1(v)$  is the vector function of the curve  $k_1$  determined by equation (1). This surface is surface of torus.

The three-revolution cyclical surface of the type  $P_3^{gh}(u, v)$  is created by translation of the circle  $c_3 = (R_3, r_3)$  along the curve  $k_3$  at an angular velocity  $w_3 = m_2 m_1 v$ , where the circle is always in the plane  $(n_3, b_3)$  if the index  $h = t$ , or in the plane  $(t_3, b_3)$  if  $h = n$ , or in the plane  $(t_3, n_3)$  if  $h = b$  and its centre is the point  $R_3 \in k_3^{gh}$ . We will create it so that the circle  $c_{03}$  determined by the vector function  $c_{03}(u) = (0, r_3 \cos u, r_3 \sin u, 1)$  if  $h = t$ , or  $c_{03}(u) = (r_3 \cos u, 0, r_3 \sin u, 1)$  if  $h = n$ , or  $c_{03}(u) = (r_3 \cos u, r_3 \sin u, 0, 1)$  if  $h = b$  we will transform into the circle  $c_3$  in the coordinate system  $(R_3, t_3, n_3, b_3)$  using the matrix  $M_3(w_3)$  by equations (5). The vector function of the cyclical surface of the type  $P_3^{gh}(u, v)$  is

$$P_3^{gh}(u, v) = r_3(v) + c_{03}(u) \cdot M_3(w_3),$$

$$u \in (0, 2\pi), v \in (0, 2\pi). \tag{10}$$

where  $r_3(v)$  is the vector function of the curve  $k_3^{gh}$  determined by (7).

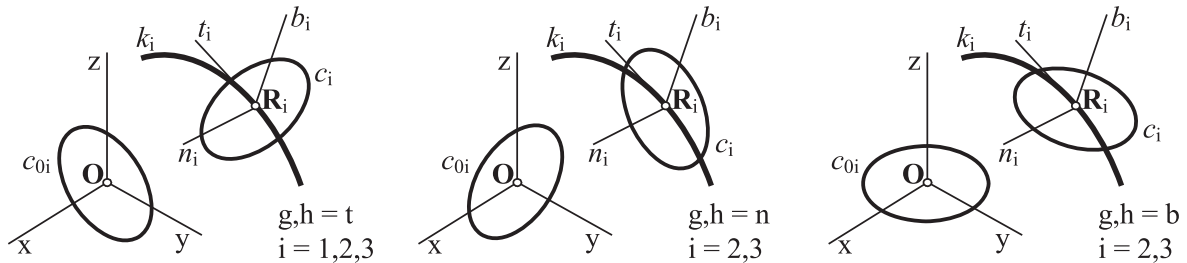

Fig. 4 Transformation of the circle  $c_{0i}$  into the circle  $c_i$

**4. Classification of cyclical surfaces of the type  $P_2^g(u,v), P_3^{gh}(u,v)$**

The two-revolution cyclical surface of the type  $P_2^g(u,v)$  can be classified according to the index  $g$ :

Table 1: Classification of cyclical surfaces of the type  $P_2^g(u,v)$

$g$	$t$	$n$	$b$
	$P_2^t(u,v)$	$P_2^n(u,v)$	$P_2^b(u,v)$

The three-revolution cyclical surface of the type  $P_3^{gh}(u,v)$  can be classified according to the index  $g$  and  $h$ :

Table 2: Classification of cyclical surfaces of the type  $P_3^{gh}(u,v)$

$g/h$	$t$	$n$	$b$
$t$	$P_3^{tt}(u,v)$	$P_3^{tn}(u,v)$	$P_3^{tb}(u,v)$
$n$	$P_3^{nt}(u,v)$	$P_3^{nn}(u,v)$	$P_3^{nb}(u,v)$
$b$	$P_3^{bt}(u,v)$	$P_3^{bn}(u,v)$	$P_3^{bb}(u,v)$

**5. Illustrations of cyclical surfaces of the type  $P_1(u,v), P_2^t(u,v), P_3^{gh}(u,v)$**

In Fig. 5 there are displayed three combinations of cyclical surfaces of the type  $P_1(u,v), P_2^t(u,v), P_3^{tt}(u,v)$  in fig. a),  $P_1(u,v), P_2^t(u,v), P_3^{tn}(u,v)$  in fig.b),  $P_1(u,v), P_2^t(u,v), P_3^{tb}(u,v)$  in fig. c).

In Fig. 6 there are displayed three combinations of cyclical surfaces of the type  $P_1(u,v), P_2^n(u,v), P_3^{nt}(u,v)$  in fig. a),  $P_1(u,v), P_2^n(u,v), P_3^{nn}(u,v)$  in fig. b),  $P_1(u,v), P_2^n(u,v), P_3^{nb}(u,v)$  in fig. c).

In Fig. 7 there are displayed three combinations of cyclical surfaces of the type  $P_1(u,v), P_2^b(u,v), P_3^{bt}(u,v)$  in fig. a),  $P_1(u,v), P_2^b(u,v), P_3^{bn}(u,v)$  in fig.b),  $P_1(u,v), P_2^b(u,v), P_3^{bb}(u,v)$  in fig. c).

The surfaces mentioned above can be used in design practice as constructive or ornamental structural components.

The paper was supported by the grant VEGA 1 / 4002 / 07.

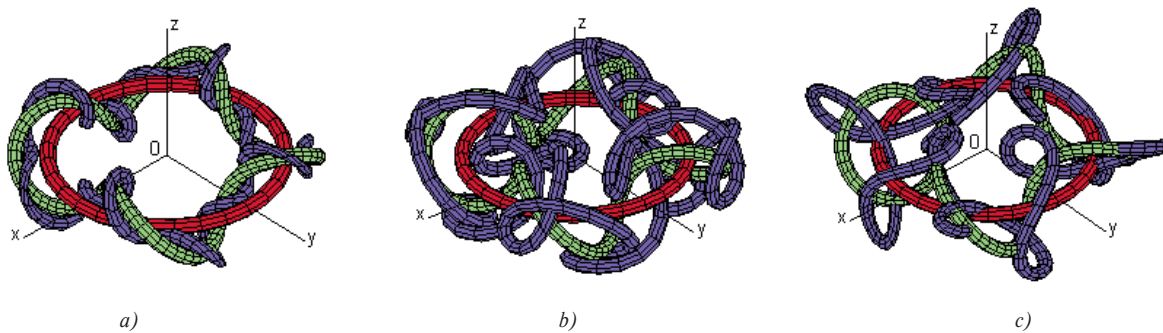

Fig. 5 Combinations of cyclical surfaces for  $g = t$

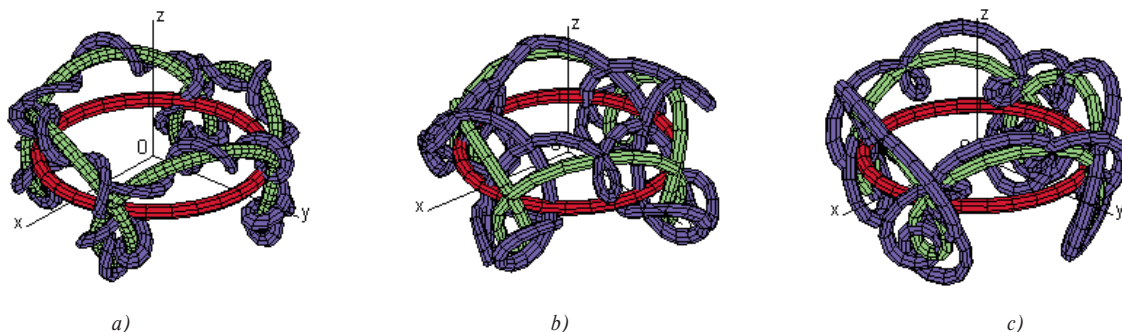

Fig. 6 Combinations of cyclical surfaces for  $g = n$

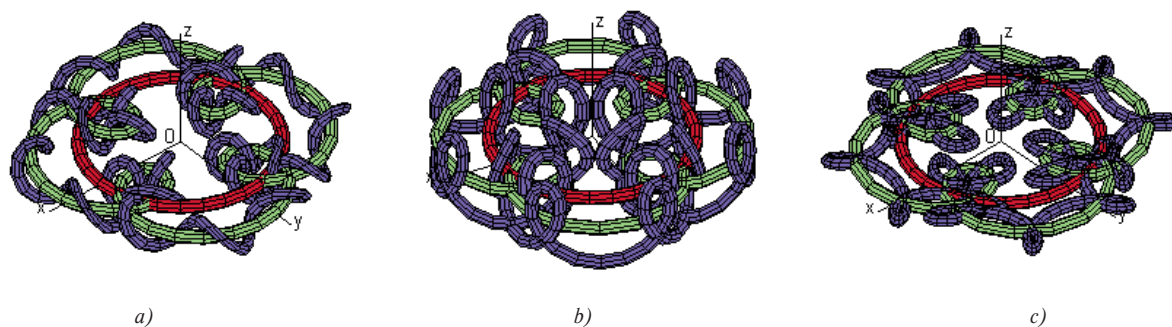

Fig 7 Combinations of cyclical surfaces for  $g = b$

## References

- [1] OLEJNIKOVA, T.: *Straight-lines Spiral-rotary Planes (in Slovak)*, Proc. of 26. konference o geometrii a pocitacove grafice, 2006, Nove Mesto na Morave, CR, 2006, p. 15-28, ISBN 80-7040-902-9.
- [2] OLEJNIKOVA, T.: *Straight-lines Spiral-rotary Planes II (in Slovak)*, Proc. of 6th International Conference APLIMAT 2007, Bratislava, 2007, p. 231-236, ISBN 978-80-969562-4-1
- [3] KOHOUT, V.: *Differential Geometry (in Czech)*, SNTL-Publishers of Technical Literature, Praha, 1971.
- [4] GRANAT, L., SECHOVSKY, H.: *Computer Graphics (in Slovak)*, SNTL - Publishers of Technical Literature, Bratislava, 1974

## BOOK REVIEW

**Kavicka, A., Klima, V., Adamko, N.:**  
**Agent-oriented Simulation of Traffic Nodes,**  
 ISBN 80-8070-477-5

The edition house EDIS released a very interesting (and for the Slovak and/or Czech speaking people very important) book titled *Agentovo orientovaná simulácia dopravných uzlov* (Agent-oriented Simulation of Traffic Nodes). The authors are A. Kavicka, V. Klima a N. Adamko and the book is written in Slovakian. The first phrase presented at the last page of the book cover can be translated as follows: "The subject of the monograph is methodology of developing really applicable simulation models of complex service systems, especially models of traffic nodes as systems with dominating or prevailing function to relocate elements." That statement well characterizes the contents of the book. Really, the rich concluding chapter of the book concerns the railway traffic and we can disclose that the whole contents of the book arose under the influence of the demands of railway transport, though it can be applied as a set of efficient stimuli outside the railway systems simulation, too - the operation transport in production systems, the road transport and the dynamics in sea ports and container terminals can be presented as examples.

In the introductory chapter, a system analysis of marshalling yard is presented. Although one could view it as a certain preparing to the last chapter of the book, the essence of this chapter is to present a more or less elementary rational steps that have to be present before realizing any applicable simulation model: from the pedagogical point of view, the marshalling yard serves a certain representative of other systems that could be studied by using simulation, a representative that needs no special professional knowledge of a branch (almost every expert in production, design, management and other branches of technology knows something on trains, wagons, stations and links among them, so that he understands even in case he is not a professional in traffic problems). The second chapter contains an analysis of general notions related to simulation. The contents of this chapter is important not only that it forms a logical and semantic base for understanding the following chapters (let us accept that the terms like simulation, model, systems and that derived from them are understood in a lot of publications over the world in a rather chaotic way); it appears as a good stimulus independently of the reader's professional orientation and can be fruitful also for the readers whose interest is e.g. production, services and ecology. In a similar way, the book overpasses the transport domain frontiers also in the following chapter, which presents and well declares the professional contents and importance of (computing) agents, including their classification and near relation to computer simulation. Simulation leads to problems of synchronization of agents, which concerns two aspects: modeling of agents functioning during the same simulated (Newtonian) time, and synchronization of computing with visual presentation of its state, namely with animation of simulation models, in real time.

The fifth chapter is a certain focus of a lot of work that the authors undertook in programming and implementing simulation software. It is known that the results of their effort were applied in Switzerland and China, i.e. that the software forms a more or less universal package of simulation and animation routines, blocks and modules, composed of more or less autonomous agents. For the implementation of them, the authors applied programming language Pascal, which is a popular tool embedded in an editing and debugging environment, but which has never been oriented to the agent programming paradigm. In Pascal, the authors had to program all what is essential for agents, especially everything related their initiative and dynamics, and they decided to use Petri nets as tools for this purpose. This chapter reflects the hardest work of the authors and may appear most difficult for many readers, but one can quiet them not to be disturbed, as there are programming tools that allow elude Petri nets. Beside the described chapters, the book contains 40 page appendix of Pascal source code; the readers knowing Pascal language will surely appreciate it.

Prof. Eugene Kindler

**Agentovo orientovaná  
simulácia  
dopravných uzlov**

Antonín Kavička  
Valent Klima  
Norbert Adamko

**COMMUNICATIONS - Scientific Letters of the University of Zilina  
Writer's Guidelines**

1. Submissions for publication must be unpublished and not be a multiple submission.
2. Manuscripts written in **English language** must include **abstract** also written in English. The submission should not exceed **10 pages** with figures and tables (format A4, Times Roman size 12). The **abstract** should not exceed 10 lines.
3. Submissions should be sent: **by e-mail** (as attachment in application MS WORD) to one of the following addresses: *holesa@nic.utc.sk* or *vrblova@nic.utc.sk* or *polednak@fsi.utc.sk* **with a hard copy** (to be assessed by the editorial board) **or on a CD** with a hard copy to the following address: Zilinska univerzita, OVaV, Univerzitná 1, SK-10 26 Zilina, Slovakia.
4. Abbreviations, which are not common, must be used in full when mentioned for the first time.
5. Figures, graphs and diagrams, if not processed by Microsoft WORD, must be sent in electronic form (as GIF, JPG, TIFF, BMP files) or drawn in contrast on white paper, one copy enclosed. Photographs for publication must be either contrastive or on a slide.
6. References are to be marked either in the text or as footnotes numbered respectively. Numbers must be in square brackets. The list of references should follow the paper (according to **ISO 690**).
7. The author's exact **mailing address of the organisation where the author works, full names, e-mail address or fax or telephone number**, must be enclosed.
8. The editorial board will assess the submission in its following session. In the case that the article is accepted for future volumes, the board submits the manuscript to the editors for review and language correction. After reviewing and incorporating the editor's remarks, the final draft (before printing) will be sent to authors for final review and adjustment.
9. The deadlines for submissions are as follows: September 30, December 31, March 31 and June 30.
10. Topics for issues: 4/2008 - Networks for New Generations, 1/2009 - Material Engineering.

COMMUNICATIONS

SCIENTIFIC LETTERS OF THE UNIVERSITY OF ZILINA  
VOLUME 10

**Editor-in-chief:**

Prof. Ing. Pavel Poledňák, PhD.

**Editorial board:**

Prof. Ing. Jan Bujnak, CSc. - SK  
 Prof. Ing. Otakar Bokuvka, CSc. - SK  
 Prof. RNDr. Peter Bury, CSc. - SK  
 Prof. RNDr. Jan Cerný, DrSc. - CZ  
 Prof. Eduard I. Danilenko, DrSc. - UKR  
 Prof. Ing. Branislav Dobrucky, CSc. - SK  
 Prof. Dr. Stephen Dodds - UK  
 Dr. Robert E. Caves - UK  
 Dr.hab Inž. Stefania Grzeszczyk, prof. PO - PL  
 Doc. PhDr. Anna Hlavnova, CSc. - SK  
 Prof. Ing. Vladimír Hlavna, PhD. - SK  
 Prof. RNDr. Jaroslav Janacek, CSc. - SK  
 Prof. Ing. Hermann Knoflacher - A  
 Dr. Ing. Helmut König, Dr.h.c. - CH  
 Prof. Ing. Milan Moravcik, CSc. - SK  
 Prof. Ing. Gianni Nicoletto - I  
 Prof. Ing. Ludovit Parilak, CSc. - SK  
 Ing. Miroslav Pfliegel, CSc. - SK  
 Prof. Ing. Pavel Polednak, PhD. - SK  
 Prof. Bruno Salgues - F  
 Prof. Andreas Steimel - D  
 Prof. Ing. Miroslav Steiner, DrSc. - CZ  
 Prof. Ing. Pavel Surovec, CSc. - SK  
 Prof. Josu Takala - SU  
 PhDr. Radoslava Turska, CSc. - SK  
 Doc. Ing. Martin Vaculik, CSc. - SK

**Address of the editorial office:**

Zilinská univerzita  
 Office for Science and Research  
 (OVaV)  
 Univerzitná 1  
 SK 010 26 Zilina  
 Slovakia

E-mail: [komunikacie@nic.utc.sk](mailto:komunikacie@nic.utc.sk), [polednak@fsi.utc.sk](mailto:polednak@fsi.utc.sk),

Each paper was reviewed by two reviewers.

Journal is excerpted in Compendex

It is published by the University of Zilina in  
 EDIS - Publishing Institution of Zilina University  
 Registered No: 1989/98  
 ISSN 1335-4205

Published quarterly

Single issues of the journal can be found on:  
<http://www.utc.sk/komunikacie>