

5

Jerzy M. Wolanin
**PERCEIVING, DRAMA, DISCOMFORT
- SHADOW OF DISASTER**

12

Roman Rak - Marián Mesároš - Viktor Porada
THE PERSONALITY OF A SAFETY MANAGER

20

Leszek Korzeniowski
**SECURITOLGY - THE CONCEPT
OF SAFETY**

24

Jozef Meterňko
**INFORMATION AND COMMUNICATION
CRIME**

29

Ján Mikolaj
**CRISIS MANAGEMENT IN SECURITY
ENVIRONMENT**

34

Martin Zachar
**COMPARISON OF SOME PHYSICAL
PROPERTIES OF FOAM CONCENTRATES
- PYRONIL AND ALFA A**

38

Aleš Bernatík - Šárka Horehledřová - Petra Nevrlá
**HARMONISED APPROACH TO THE
ASSESSMENT OF MAJOR ACCIDENT RISKS
IN THE FRAMEWORK OF SEVESO II
DIRECTIVE: CASE STUDY ON ARAMIS
METHODOLOGY APPLICATION**

45

Roman Jašek
**THE INFORMATION SECURITY
OF ENTERPRISES AND CITIZENS'
SECURITY CONTEXT**

49

Petr Linhart
**CURRENT TRENDS IN POPULATION
PROTECTION IN EUROPE AND THEIR
RESEARCH SUPPORT IN THE
CZECH REPUBLIC**

57

Ján Slosiarik
**TESTING OF THE FLAME SPREAD
LINEAR SPEED ON FOODSTUFFS
AND AGRICULTURE DUST LAYERS**

60

Juraj Sluka - Zdeněk Dvořák - Lenka Rošteková
**THE POSSIBILITY OF USING THE
GEOGRAPHICAL INFORMATION SYSTEMS
IN THE PIPE TRANSPORT OF THE ARMED
FORCES OF SLOVAKIA**

64

I. Milata - L. Rošteková - V. Kašpar - Z. Dvořák
**MATHEMATICAL SUPPORT OF CRISIS
PLANNING**

68

Juraj Cajchan - Oľga Poniščiaková - Miloš Poliak
**SLOVAK ROAD TRANSPORT FROM THE
POINT OF VIEW OF SUSTAINABLE
DEVELOPMENT**

72

Alica Kalašřová
**INCREASE IN ROAD TRANSPORT SAFETY
- WAY TO REDUCTION OF EXTERNAL COSTS**

76

Viera Šukalová - Oľga Poniščiaková
**IT PAYS TO MANAGE HEALTH PROTECTION
AND SAFETY AT WORK**



Dear readers,

This third number of our journal Communications in the year 2005 is devoted to the problem of security.

Security of nations and the whole mankind becomes at the beginning of the third millennium one of the greatest social and humanitarian problem. So far, democratic principles were considered as a background for safe and progressive environment for the life of communities and nations and a source of international coexistence and cooperation. Unfortunately, miscellaneous interests of different human societies lead the world into new stage of their feelings and thoughts advocacy. The world wars are retrieved by attacks of groups or individuals against societies. The local violence becomes the threat to citizens at nations. It is a duty of the mankind to detect the source and reasons of this menace. Therefore, an autonomous science and appropriate applied disciplines are now under view of scientific observation in specific knowledge field called security science. Not only overall society security, but also in connection with the development of new technologies, new phenomena such as safety of data and data media and their treatment, safety of transmission facilities, safety of secret scientific and research information, security of people and property come into consideration within this newly developing science. Further, new dangers and fears such as terrorism, scientific and technical espionage, not sufficient performance security of energetic, transport or communication facilities to jeopardy and attacks arise in the society and should be systematically considered within the framework of this new security science.

The editorial board of the journal Communications would like to contribute to the discussion of security problems and has, therefore, decided to present a specific number dealing with the above issues. Some authors express their opinions about security problems. We would like to believe that you will find the articles both interesting and instructive. The editorial board will be grateful for your comments on this topical subject.

Pavel Poledňák

Jerzy M. Wolanin *

PERCEIVING, DRAMA, DISCOMFORT – SHADOW OF DISASTER

When speaking about psychology of rescue actions there should be no restrictions to the incident only but the problem should be studied within the whole time, i.e. before, during and after the event. Disaster is irreversibly connected with a tragedy that falls deeply into social memory. Frequently it changes irrevocably the way of living of individual people and whole local population. Nonetheless, as time passes emotions connected with the disaster decrease. And even though that for various individual people the passage of time may not be of such profound importance, in the case of local population indifference grows to possible future incidents of this sort. Thus we are faced with a situation in which greatly faded emotions connected with "past" history coexist with the hope that the same thing would not take place in future. In the article this period of time is defined as a period "after-before" the disaster and is related to the period of drama and the period of discomfort.

Small or big rescue actions, complicated ones or those quite "simple" – tend to leave traces in the psyche of their participants, always and without any exceptions. The victim, the rescuer, his commander, the decision-maker, and even incidental witnesses – all of those people, whether they want to or not, become emotionally engaged in this type of incidents, although they play different roles, this type of engagement has a completely different dimension to each of them. After all, each dramatic sudden incident leads to defined tension. Those incidents take place not only in a physical dimension of each man, but also on the mental level, and to put it more widely in a social dimension as well, as we are dealing here with groups of people. It is also quite obvious that each person experiences this compulsory participation in a real drama in an absolutely individual way. At the same time, because of the fact that during rescue actions we are faced with groups of people, to be observed are emotional group reactions, which are different for various groups. Those reactions are not only due to the role that is fulfilled in a given incident by a certain group – such as rescuers, the endangered part of local society, experts – but also due to the acquired experience, common history, and cultural premises. The latter may also exert significant direct influence on the course of a rescue action. For example in Holland, in the case of a threat to life a rescuer has priority before the rescued. Such an attitude resulted from experience of Dutch firemen; during one of the actions of fire extinguishing eight firemen lost their lives when rescuing people from a house on fire, which in the end collapsed and buried all underneath. Such an example shows that the past influences the present, both in the scope of undertaken actions, and in the scope of the emotional state. Hence when we speak of psychology of rescue actions we should not restrict ourselves only to the incident itself, but the problem should be instead studied within the whole time: before, during and after the event. To allow a clearer emphasis of certain problems let us focus on major incidents – those that may be ascribed to disasters. A dis-

aster is irreversibly connected with a tragedy. It falls deeply into social memory. Frequently it changes irrevocably the way of living of individual people and of whole local population. Nonetheless, as time passes emotions connected with the disaster decrease and despite the fact that for various individual people the passage of time may not be of such profound importance, in the case of local population indifference grows to possible future incidents of this sort. Hence we are faced with a situation in which greatly faded emotions connected with "past" history coexist with the hope that the same thing would not take place in future. Let us define this period of time as a period "after-before" the disaster. It is worthwhile to analyse in what way is a threat of possible drama perceived within that range. How is it perceived by its later participants?

Perceiving

As we have already mentioned, the more time has passed since the disaster, the smaller its influence on the emotional state of its participants. Roman Ingarden wrote that a human being "... manages to realise – thanks to his victories, and even through his defeats – the values of Good and Beauty.(Ingarden R. 1998).", but also strives at prosperity, and focuses his attention on the creative work of self-realisation. All that may constitute an obstacle to the achievement of those goals constitutes in "normal life" only a secondary background. A background that is obscure, distant and unreal. As a rule in the consciousness of various people, and above all in the common awareness of local communities, matters connected with hazards are either underestimated – on the level of apathy, or else exaggerated. And despite the fact that what we have in mind here about constitutes a subjective perception of a hazard, in Sandman's (Sandman P. 1997) opinion it belongs to reality not less than the physical existence of the hazard itself. This matter is of particular importance and constitutes a key to comprehending

* Jerzy M. Wolanin

The Main School of Fire Service, Slowackiego 52/54, PL-01-629 Warsaw, Poland, E-mail: Jerzy.Wolanin@sgsp.edu.pl

differences concerning perceiving of hazards on the one hand by experts (this group shall include in this case also rescue services), and on the other hand – by the local community.

When analysing hazards, experts tend to apply as a rule engineering evaluation methods (in this case precise calculations are impossible) of the possibility that an unfavourable incident might occur and for the determination of its consequences. In the experts' opinion this constitutes the only objective evaluation of the existing situation, devoid of "emotion", and consequently a real one (with accuracy equal to precision of calculation method). As a rule they are convinced that social feelings are not essential, as they are subjective, frequently based on legends, unclear remembrances, and hysterical evaluations. But above all experts presume that such evaluation lack premises based on "honest" engineering knowledge. The phenomenon of occurrence of such profound differences in perceiving hazard between experts and local society is not rare and bears the name of "expert arrogance" (Wynne B. 1992). This conflict is not insignificant at all. After all, refusal of opinions expressed by local community in matters that concern them to such an extent (in such a vital way) may lead to several dangerous conflicts (Healy S. 2001). The most dangerous of them include, among others, the possibility of setting up a law that would impose against the will of the community solutions that conform to the engineering expert ideology, which as a rule permit numerous means of duress (e.g. compulsory evacuation). Other dangers connected with not taking into account of social opinion include also taking a decision on the constructing an industrial plant processing dangerous chemical substances in spite of social protests, but instead in conformity to calculations of experts. After all, such protests may turn into social unrest and in the case of some breakdown (which may not be ruled out even by the most accurate calculations) into behaviour inadequate during rescue actions. Sandman, whom we have already quoted, wrote in his book (Sandman P. 1997) that the correlation between an expert's opinion and social assessment in the scope of hazards took place already on the level of 4%. To put it more simply, this means that for each hundred cases of hazard evaluation, in 96 cases they are divergent. The mathematical interpretation of the fact is that hazards evaluated by both groups constitute almost independent variables. In other words, it is indeed true that experts say one thing and the people another thing. The fact that experts accuse a simple citizen of his having insufficient knowledge is understandable from the intuitive viewpoint. But why do people have so little confidence in experts? This is due to a lot of reasons. One of them is the frequent conviction that experts are paid by people that await in return a particular result of an expertise, like for example representatives of industry. This universal conviction that an expertise serves somebody's particular interests did not spare also rescue services themselves. Many decision-makers for example are convinced that hazards are overestimated to allow the acquisition of additional expensive equipment. Nonetheless, to a large extent the essence of conflict is a lack of social agreement – contrary to the opinion of experts – for the establishment of new risk sources (e.g. construction of chemical facilities, transit road for transport of dangerous materials, or perhaps – as it happened in Poland – the construction of a nuclear power plant in Żarnowiec). At this point one should

keep in mind that during such conflicts it is experts who lose as a rule. This was exactly the main reason why Sandman – who as he admitted was dealing with risk communication – was forced to redefine the concept of *risk*. This definition that is particularly worth attention is as follows:

$$Risk = assessed\ hazard + outrage$$

In conformity to the above definition risk comprises two basic elements. The first one is the assessed hazard, which is nothing but risk defined in a classical way. This concept includes the ratio of probability that the unfavourable incident occurs, as well as its consequences. Hence the assessed hazard is comprehended by the experts as risk.

$$Risk = probability\ of\ occurrence\ of\ an\ incident \times \\ \times\ consequences\ of\ the\ occurring\ event$$

As it may be seen the language of risk (in the understanding of experts) is the language that determines possibilities of occurrence of incidents multiplied by their "magnitude". This is not the language connected with conviction. In social perceiving the language of suppositions does not express clear opinions. It leaves a large field for guesses. This is due to the fact that from the point of view of a modified definition of risk, experts attach excessive attention to the first part of the risk, as a rule ignoring the second one. On the other hand, in the social opinion the first part does not have such importance as the second one does. Consequently it is necessary to solve the question which of the elements is more connected with risk? Is the value of risk predetermined by assessment of probability of occurrence of a disaster and its consequences? Or is the risk value determined by social reception? In other words, which of the mentioned factors has a real influence on risk? When seeking an answer to this question, one should fully agree with Sandman that both factors exert a real influence on risk and both are equally significant. He stated as follows:

"... Societies frequently perceive hazards in an incorrect way. Experts frequently perceive social unrest in an incorrect way. Yet the essence of the issue is the fact that communities pay too little attention to hazards, while experts pay insufficient attention to social unrest ..."

In such a way both parties speak only of risk components, and not of risk as a whole. In order to allow full explanation of the discussed problems, let us make use of an example quoted by Sandman himself. A skier who likes to ski on steep mountain slopes does not consider his hobby as risky. "A classical" expert would state that a skier has a hobby of considerable risk. Nonetheless, owing to their voluntary character, ski jumps do not cause any anxiety. One of the risk components consequently becomes insignificant (in this case it equals zero), hence the risk is small, although a very serious hazard does exist.

The bigger the voluntary character of "giving in" to hazard, the smaller the risk.

This is one of the most fundamental conclusions from our deliberations. Preparations for further rescue actions may not disregard this fact. If in our understanding the acceptance of risk is an agreement – to a bigger or smaller extent a voluntary one – to risk exposure, then it may be ascertained that such a subjective element as risk acceptance lowers the value of that risk. On the other hand, can we take a decision of going to a dentist about whom we know that his HIV test is positive. Going to any dentist like that means this type of hazard. A dentist aware of his having a positive HIV test result shall apply additional safety measures. Hence the hazard of infection is even smaller than if when a dentist – and particularly we – are not aware of the test results. In such a case no such additional safety measures are applied. Anyway, shall we go to a dentist whose HIV test result is positive? In such a case the dominating factor is anxiety. Consequently the risk is so high that going to “our” dentist becomes problematical. May in connection with that the anxiety factor be further considered to be illusory? Do both factors have the same influence on the risk value? The voluntary character is not the only element that influences perceiving of risk. The below table illustrates also other elements which have an influence on risk perceiving, and hence its value (Klein R. A. 1997).

Selected elements that have an impact on risk perceiving (Klein R. A. 1997)

Table 1.

Criteria	Perceiving of risk	
	Perceived as lower	Perceived as higher
Source	Natural	Civilisational
Voluntary character	Voluntary	Involuntary
Disclosing	Immediate	Delayed or unnoticed
Severance (number of endangered people)	Common: a few endangered persons	Disastrous: a lot of endangered people
Limitation	Controllable	Uncontrollable
Profit	Obvious	Obscure
Familiarity with risk	Known	Unknown
Endangerment to: frequent risk infrequent risk	Frequent Infrequent	Accidental Frequent
Necessity	Indispensable	Superfluous (luxury)

Let us ponder for a moment how possible disasters are being treated by decision-makers. When we speak of decision-makers, we understand local self government authorities, as in a self-government *poviat* it is the district authority (the *starost*) who is responsible for safety of *poviat* inhabitants (in the town – the mayor). His role during a disaster becomes of key importance. Despite the fact that it is not he personally who is supervising the rescue action, yet frequently the effort of rescuers may get to waste without his participation. A good example may be constituted here by taking care of inhabitants who are evacuated in winter without their possessions from a house on fire. Statistic data prove that they include sick, old and handicapped people. The drama of those people is not ended when the direct hazard to their health and life has been

removed. After all, that is when new kinds of dangers do appear: an intense stress that may lead to a heart attack, possibility of getting pneumonia etc. Hence it is important in what way the shadow of the future disaster is being perceived by people who according to the law are to protect us from it. Those people naturally also included in the generally obligatory rule in such cases: the more time has passed from the last disaster, the stronger the feeling of apathy. The wishful thinking, and namely “this is not going to happen here”, constitutes a rule here. That is why decision-makers frequently experience an inner conflict based on the fact that services connected with rescue actions pose demands the fulfilment of which is very costly – budgets are always too low – and that frequently makes them impossible to fulfil. One should keep in mind that the appointment of self-government authorities in Poland has not much in common with their programmes concerning protection against hazards. They are as a rule connected with economic and cultural development of a region, and not fighting phenomena that may disturb that development. Stress resulting from this conflict is increased by the fact that the appointed *starosts*, mayors or presidents of towns are not specialists in such a complicated field – in their opinion – as hazard management. Things are not made any easier to them when specialist services assure that they should take over rescuing of people as they are able to do that much better, after all, rescuing has a slightly different meaning for either of them. Many decision-makers are tempted and actually do leave matters connected with safety up to rescue services. Unfortunately, this constitutes a manifestation of the already mentioned apathy. Safety management is not exclusively limited to the ability of reacting. It has a much wider dimension, and frequently encroaches the field of politics, and consequently it is much closer to authority, and not to specialist services. This is all the more correct as protection of local society includes not only the classical understanding of life, health, possessions, environment, but also everything which in the scale of a *poviat* (*gmina*, township or town) constitutes the essence of local community and hence of all social, cultural, business, and even neighbourhood ties. Such a widely understood thinking about protection of local society is surely closer to a politician than to a specialised service. The activity of a politician in this scope is a question of overcoming his own feeling of apathy. The floods that have occurred in Poland in 1997 proved that many local politicians were surprisingly efficient in management during the crisis itself. It should be emphasised that nobody had prepared them for this role. Before the flood, as usually in the time period “after-before” the catastrophe, they were rather characterised by an apathy in the issue of floods. Nonetheless, there is another side to the same coin. The government decision-maker, knowing that he is responsible for safety of people, thanks to his authority can order the implementation of appropriate plans in case of a disaster. Apart from the fact that this is only an element of the whole task, one should keep in mind that plans on paper as a rule constitute a very small value if not verified, i.e. they are not included in the whole management procedure. Unfortunately the confidence directed only at paper constitutes another manifestation of apathy, known in this case as the “paper syndrome”. The awareness that plans are available is reassuring. It causes a situation in which we tend to justify not taking up of several undertakings connected with the process of safety management, including undertakings

indispensable for possible rescue action. This type of stifling the voice of one's conscience turns back against a person very quickly. Inadequate plans are much more dangerous than none. The lack of plans makes one wonder over the way of acting in case of a possible disaster. One asks oneself what one would do if the given incident were to happen. On the other hand, if plans are available, I have nothing to worry about, because they have all the necessary information. Unfortunately the paper syndrome is a frequent illness and no country is free of it. The only question that remains is in what way the same protection system obligatory in a given country is able to defend itself against the consequences of that illness.

Drama

The phase "after-before" the disaster is characterised by a static progress. It may seem to all interested persons that they have a lot of time in their hands. In practice the pressure of time, which is one of the most significant stress inducers, is - if one may say so - neglectedly low until the moment when the disaster occurs. Of course the situation changes from the moment on when the disaster starts its destroying work. Let us focus on the disaster, which occurred all of a sudden, on a vast area or, which is equivalent from the point of view of our deliberations, with a high number of victims, but on a small area. A characteristic trait of the initial phase of such a disaster is either a lack of information or the inflow of a large quantity of information, about which one may only say that they are contradictory. This problem concerns all participants of such an incident. It is worthwhile to mention them here. They include victims, rescuers, and local decision-makers, higher ranking decision-makers, relatives and friends of the victims. The latter group of disaster participants frequently - but not always - is outside the range of interest of those who bring help to the victims. And after all also those people belong to the group of victims. Often one may see on the television screen the despair or hysterics of people waiting at the airport after an airplane disaster. Unfortunately in the majority of this type of disasters those are the only victims in need of help. And although this disaster was hundreds of kilometres away from the airport, its shadow knows no space boundaries. It spreads as quickly as information. We can see it in the despair of people. When preparing rescue plans, or in the process of civil planning, do we take into consideration this group of people gathered on a small space and hit by the tragic news? Is their condition within the category of psychology of rescue undertakings? The answer is clear. This group is composed of victims. Victims need help. The fact that this type of help is taking place in a different way than that understood in the classical sense, that it requires different methods and tools is of no importance here. Those are victims in need of help.

The sudden character of the incident, in connection with the lack of information or the inflow of contradicting information, are of course stresses generating factors. Acting under pressure of time causes that even a well-trained rescuer focused on manual actions is liable to make mistakes connected with the assessment of real condition of the victim. A typical example here may be constituted

by the rescuer not recognising the shock in which the victim is. Consequently, in case when there are no external injuries, the victim is left on his own. Of course, after he had been taken away from the place of direct danger. That is why a few years ago we could see in the news an interview with a victim of an airplane crash. The interview was taking place on the Warsaw Okęcie Airport, directly after the victim was taken out of the airplane, and was on his way home, unstopped by anybody, except the journalist. Rescue procedures do not include those victims who had suffered "nothing" apart from being in shock. As a rule the action of the rescuers end once the victims are taken to a safe place. But what does a safe place mean? After all, if a shocked victim is in a place he is not familiar with it may only make his condition more serious. Even if he is taken to a hospital, and maybe because of the fact of being there (NIMH 1990)? Rescue actions must be subordinated to the needs of victims in every possible way (Palmer M. 2001). Each action requires an individual approach, a different strategy. A child lost in a wood at dusk may be seriously frightened and may experience shock when the rescuer appears, in full uniform and with his face covered by a mask, looking more like an alien. Similar shock was experienced by a woman imprisoned in a cellar after the earthquake in Armenia, where she was found by a French rescuer. He was dressed in his wonderful shining helmet, completely unknown for the victim. The shock was made even more profound by the fact that the victim was not aware of the earthquake itself, and was convinced that her town had been bombarded by the Germans (shadow of the preceding disaster from the period "after-before"), and now one of the invaders was coming to get her (VII International Conference of Principals of Civil Protection Schools Paris 1997). Such a shock could have been experienced by a girl, imprisoned inside a car and unable to observe her surroundings, if her request - spoken to the psychologist holding her hand - for the rescuers to act more quietly was not obeyed. The rescuers gave up the application of hydraulic tools to cut the chassis and used manual equipment. The action took an hour longer (Programme "911" BBC Prime). Unfortunately at the moment no scenarios of the course of events during a disaster can take into account the behaviour of victims. The only exception may be constituted by panic, which - as is shown by statistics - is not a frequent phenomenon.

It is worthwhile to have a closer look at another group of people, who are not rescuers and yet who actively participate in the rescue actions: dispatchers. Those are people who handle information. They participated in the incidents listening to what was happening. Although their knowledge is only limited to what they hear, it might prove to be absolutely sufficient to cause shock, trauma or behaviour connected with deep emotions. Those deliberations are not purely academic. On the Baltic Sea a rescue training was planned at night time. All the teams participating in the exercises were informed about them, including the Alarm Centre in Turku, Finland. Several hours before the exercises one of the biggest tragedies of the last years took place. The Estonia ferry started to sink. The closest Alarm Centre was the one in Turku. It was there that the first information was received. The dispatchers with absolute calm fulfilled their duties in a routine way, fully convinced that it was only the planned exercises that had been com-

menced. Unfortunately this was not a favourable circumstance. As time passed they became aware of the fact that life itself wrote the scenario to this tragedy. Each of them had a shock and required help. And this time the shadow of the disaster reached far beyond the place of incident.

The drama of decision-makers, and particularly of the local ones, is not only based on the fact that they must handle something they have not been faced with before. They come into contact with matters they are completely not familiar with. They must work in the surroundings of people who are frequently upset, acting under pressure of time, not having full information at their disposal. Those conditions are naturally highly stress-generating, but – as was already mentioned – that is not the most difficult aspect of it. The biggest fear of a politician is a political death if things go wrong. The loss of social respect, the loss of authority among people for whom he is fulfilling his political mission cause the strongest emotions. If the disaster appears suddenly, without warning, decision-makers are faced with its consequences before they are able to do anything. The mass media turn up. During one of flash floods on the south of France, after an extremely difficult 24-hours spent in the centre of rescue co-ordination, the mayor of one of the townships in which the flood had occurred read in the presence of his wife and his children a headline in the local press: “... bloody hands of the mayor ...” (VII International Conference of Principals of Civil Protection Schools Paris 1997). It may be said that for this respected local politician his hitherto world has been completely ruined. It has no sense to ask whether opinions of the journalist were justified. It is not possible to explain to everybody how things really were. This is the highest price that a politician may pay. One ought to add that the share of local governments in rescue actions is of key importance. In the case of rescue actions on the area of a *poviat* it will be the *starost* who will be taking numerous decisions of a political character connected with the rescue action. An example of such an action may be the decision of blowing out the dam which would cause flooding of the village but saving a bigger district or a town. Such a situation took place during the floods in Poland in 1997. This type of decisions is always unpopular and always must be taken during fighting consequences of a disaster.

At the end of this part of the deliberations it would be worthwhile to quote results of tests conducted by Grissen from the University in Frankfurt/Main, and published in the October edition of Fire International (Grissen B. 2000), in the article entitled “Alarm Calls – Watching closely stress in the watch-tower”. In her publication the author compared the influence of some stress factors on firemen during rescue actions and the same stressors during the period of readiness. Eight stress generating areas were determined: environmental (the closest surroundings of the fireman), risk of accident, co-operation, pressure of time, concentration, uncertainty, complexity, freedom of taking decisions. As could have been expected it was ascertained that generally challenge in rescue actions are bigger than in the time of readiness. Yet making conclusions on this basis that stress resulting from rescue actions is the main reason for problems facing rescuers is not absolutely true. Studies have shown that tasks connected with bigger chal-

lenge do not cause an increase in negative influence provided management is well organised. Otherwise appears stress leading to illness symptoms. During rescue actions accepted are certain handicaps connected with management, as everybody is well aware of the time pressure. The very same handicaps in the time of readiness – the time “after-before” the disaster – are already not acceptable, as they fail to fulfil expectations of various persons. It ought to be emphasised that if we had used Sandman’s language we would find out that in the second case the factor of unrest increases. Another interesting result of the studies is the statement that a determining factor connected with psychosomatic problems is not age of the rescuer, but the time of his overall service. Differences in expectations connected with service during implementation of tasks during the readiness phase in the barracks lead to considerable stress (I am not a fireman so I don’t have to do the cleaning), which could not have happened during rescue actions. This very generalised summary of some results of the author’s studies also indicates other stress generating factors that influence the rescuers, apart from those generally known and studied.

Discomfort

The disaster lasts so long until the victims have achieved the condition of health and emotional state closest to the one before the disaster. The shadow of the experienced disaster is impossible to be removed. What may first of all be observed after the disaster is the rapidly vanishing interest in matters connected with it. Very quickly the phase “after” the disaster passes into the “after-before” disaster with the apathy that is characteristic for it. And one must not forget that consequences of a disaster might appear immediately after the disaster or long afterwards. In the below table NIMH 1990 presented were some relation of victims set up in age categories.

The shadow of a disaster is particularly intense in the phase after the disaster. And despite the fact that no direct life endangerment occurs all the people involved suffer. Studies (Cohen R., Ahearn F. 1980) indicate that the phase “after” comprises a series of stages. The first one concerns the time at the moment when the disaster occurs and immediately after its occurrence. At that time emotions are very strong and include: fear, torpor, shock, loss. People become aware of the challenge they face and start to heroically react to it to rescue one’s own life and that of others, as well as property. Dominating are altruistic attitudes, and people cooperate well one with another in the rescuing of others. The biggest help on this stage is obtained by the victims from their families, their neighbours and rescue services. The second stage lasts generally speaking from one week to a few months after the disaster. The symptoms are as follows: change in appetite, problems with digestion, trouble with sleeping and headaches. Moreover, such states as anger, distrust and irritation may appear. The victim may become depressed, indifferent and passive towards the family and friends, as well manifest increased anxiety about the future. On the other hand, victims and those who have lost their closest relatives (as we have already mentioned, the latter group are also victims) feel eager to share one’s experience with others. The third

Some relation of victims in age categories (NIMH 1990)

Table 2

Reactions in pre-school age	Reactions in the age group up to 10 years	Reactions of teenagers	Reactions of adults	Reactions of older people
*Crying *Sucking the thumb *Diarrhoea, wetting *Fear of remaining alone *Irritation *Embarrassment *Immobility	*Headaches, other ailments *Depression *Discomfort connected with the weather, with safety *Embarrassment *Unhappy appearance *Inability to concentrate *Hiding behind the backs of others *Fighting	*Headaches, physical other ailments *Depression *Embarrassment *Unhappy appearance *Aggressive behaviour Passive behaviour, isolation *Change in relation to friends	*Psychosomatic problems, such as ulcers and problems with the heart Passive behaviour, distrust, irritation *Anger *Lack of appetite Problems with sleeping Loss of interest in everyday activity	*Depression, passive behaviour *Apathy *Disquiet, anger *Irritation, distrust *Disorientation *Embarrassment *Loss of memory *Hastening of the ageing process Increased number of psychosomatic changes

stage that lasts approximately a year is characterised by a strong feeling of disappointment, bitterness, and acrimony when help is late, and promises and governmental support are not implemented. Many people discontinue the action in favour of one's own local community, as they are busy with their own matters. And finally the last stage, which lasts a few years, connected with the reconstruction of own houses, reorganisation of business, connections etc. During that period the victims gradually take over the initiative connected with reconstruction of their welfare. New physical development plans, development plans for the region, and support of local authorities once again help regain the faith in the sense of the society's functioning. Gradually, year after year, the phase "after" turns into the phase "after-before". In many cases only discomfort remains. Thus the cycle closes.

It seems that the diagnosis concerning decision-makers is simpler, yet it should be formed with care. The decision-maker who failed is defeated from the political viewpoint and from that time on belongs to the group of victims of the disaster, including all the consequences resulting from that fact. New authorities, at the beginning very sensitive to the condition after the disaster, are busy with new development of the region, with a vision of flourishing, as time passes start to feel discomfort when they think about the next disaster. The shadow of the disaster weakens. If the politician "succeeded", as may be shown by the example of flood in 1997, he gains a lot of social acknowledgement and quickly proceeds with further political career.

The matter of rescuers is slightly different. Not long ago, until the time when the floods have begun, many commanders were convinced that a rescuer needs no psychological protection. Many of them still continue to think so. They do not appreciate the fact that better understanding by the rescuer of own behaviour in extreme situation allows decreasing the influence of this situation on his emotional state (Paton D., Flin R. 1999). In the quoted publication the authors draw attention to the fact that coming to

oneself after a difficult rescue action as a rule takes place once the rescuer is back home. The following are a few problems connected with that:

In many cases the rescuer returns home after work worn out. He needs to rest even a few days. This fact leads to a lot of problems in everyday life at home. The family wishes more attention, time and energy.

During rescue actions quick walking is required. Consequently, in many cases the rescuer, even when already not on duty, continues to walk quickly. He takes up successive tasks, throwing himself at them, keeps moving quickly, otherwise the feeling of guilt overcomes him.

He stops to tolerate people who in his opinion move too slowly. He becomes irritated as he perceives other people as lazy, not engaged or too slow.

He has an overwhelming need of talking incessantly about his experience from the actions, despite lack of interest of the others, and does not let others speak.

The rescuer considers the lack of interest of other people in rescue topics as lack of interest in his person.

There is also a situation when members of the family want to talk about a difficult action while the rescuer still has not been able to cope with it. He may perceive it as their being meddlesome. The phenomenon of wanting or not wanting to speak is very typical in such cases.

The whole conflict is that expectations of the rescuer after a difficult action differ basically from the reaction of his family. Naturally the problem discussed here constitutes only a tiny section of problems connected with emotions of rescuers. The problem is

that their superiors are to a large extent unaware. It may not be excluded from the problems connected with psychology of rescue actions.

Different emotions are evoked when the rescuer is in watchtower and waits for an alarm. The essence of the rescuer's job is acting, and not waiting. If there is not a sufficient number of actions, the feeling of discomfort appears.

The series of problems discussed in this paper is connected with the phenomenon of the disaster. It constitutes for them the common denominator. Hence they are within the scope which might be called the **psychology of disasters**.

References

- [1] INGARDEN, R.: *Booklet of the human (in Polish)*, Wydawnictwo Literackie Kraków, 1998, pp. 17, Polish edition.
 - [2] SANDMAN, P. M.: *Responding to Community Outrage: Strategies for effective Risk Communication*, American Industrial Hygiene Association Fairfax, Va. Fourth Printing 1997.
 - [3] WYNNE, B.: *Risk and Social Learning: Reification to Engagement*, Social theories of risk edited by Sheldon Krinsky and Dominic Golding, 1992, pp. 225-297.
 - [4] HEALY, S.: *Risk as social process: the end of "the age of appealing to the facts"?* Journal of Hazardous Materials 86, 2001, pp. 39-53.
 - [5] KLEIN, R. A.: *Monograph on Risk Assessment for the Emergency Services*, The Institution of Fire Engineers, 1997.
 - [6] NIMH: *Prevention and Control of Stress Among Emergency Workers*, A Pamphlet for Workers, U.S. Department of Health and Human Services. National Institute of Mental Health, 1990.
 - [7] PALMER, M.: *Doing it by the book: a paradox in disaster management*, Australian Journal of Emergency Management Spring 2001, pp. 40-44, p. 85.
 - [8] VII International Conference of Principals of Civil Protection School. Paris 1997.
- Programme "911" BBC Prime
- [9] GRISSEN, B.: *Duty Calls - Keeping a watchful eye on stress at the fire station*, Fire International, October 2000.
 - [10] COHEN, R., AHEARN, F.: *Handbook for Mental Health Care of Disaster Victims*, Baltimore The Johns Hopkins University Press, 1980.
 - [11] PATON, D., FLIN, R.: *Disaster stress: an emergency management perspective*, Disaster Prevention and Management Vol. 8, No. 4, 1999, pp. 261-262.

Roman Rak – Marián Mesáros – Viktor Porada *

THE PERSONALITY OF A SAFETY MANAGER

The main aim of the contribution is to provide a detailed review of the role of the safety manager, and to describe the specific demands of his work when enforcing safety in an institution. Attention is given both to the personal characteristics and professional qualifications necessary for performance of his work, which can be complex but also thankless, and also the psychological influences. From a practical standpoint the authors define the essential personal characteristics for the position of a safety manager, and consider ways and options on how to best select a safety manager when filling this important managerial post in an institution, from the IT environment in businesses and state entities, to professional security organisations.

1. Work specificity of safety manager

Safety can be easily defined as a permanent activity ensuring continuity of a certain key process. The process can be, for example, maintaining the existence of the State (and the State's security), securing of income from business activities (for example Business Continuity Planning – BCP), or just human life (health and safety at work and in the private life).

The duty of a safety manager can be described by the following specifications, which at the same time require the possession of specific knowledge, skills, experience and personal characteristics, which are crucial for the successful performance of his duties:

- The majority of staff in a company subjectively view *his work as redundant, restrictive or controlling*, and very rarely perceive his position positively. Safety must always be enforced (via rules, directives, laws, technological restrictions, access rights, tests, controls, rehearsals etc.), which is in contradiction to the more comfortable working environment people have been used to until now. Where rules are breached, penalties are imposed. On the other hand safety can be enforced in an intelligent human, and decent manner, and such enforcement methods are usually successful. The crucial role is the personality of a safety manager (and bodies directly superior and inferior to him in the organisational structure).
- *Safety today is technologically very complex, and requires expertise* in a number of fields. At the same time a harmony between the technological, administration, organisational and personnel solutions of safety is a must. Safety must not be solved only by technocratic tools otherwise it can fail relatively quickly. The safety manager must therefore be much more than merely a specialist focused on a narrow field.
- *Safety has a preventative character*. Safety analysis or audits, prognosis or general trends are used to develop arrangements to eliminate potential risks. Safety cannot be solved without tech-

nological solutions, which can be costly, but from the point of view of management, shareholders or owners no direct benefit from the investments is often seen. Well performed safety is not obvious from the outside. *Safety projects* are largely infrastructure in character (affecting the whole company), and it is hard to justify them on purely economic grounds. Usually no exact return of the investment can be determined (Return On Investment – ROI or by using a different economic method). More often expenditure is justified in order to protect existing investments, information or company assets. What can happen if this is not carried out ...? What extent of loss will a company suffer if email does not work for a number of days? The justifications by the safety manager must be very sensitive and diplomatic, and the manager must be fully respected and enjoy trust.

- *The safety solution must be complex and systematic*. Safety is as vulnerable as its weakest component. The target of attack (or other safety incident) is usually known, and can be traced under certain circumstances. However there is a number of ways an attack can be performed, and the level of uncertainty is very high. The safety manager must therefore have a good understanding of past safety incidents. Experience and knowledge from different types of organisation is very valuable as is the use of experience from countries different than where the safety manager is employed. For very obvious reasons not many institutions publicise their safety incidents and the resulting impacts on the institution. Apart from the knowledge, experience and analytical skills the safety manager must be gifted by prescience, professional intuition, imagination and creativity in order to be able to place himself into a mind of a potential attacker, or to be able to uncover hidden threats (technical, natural etc.), which have not yet happened. Apart from professional experience there must be also a certain professional suspiciousness, with the purpose of uncovering weaknesses. Suspicion must never slip to personal attack, and presumption of innocence must be respected. Hypothesis of suspicion must be objectively verified before any opinion is expressed publicly.

* Roman Rak¹, Marián Mesáros², Viktor Porada³

¹Czech Telecom a.s., Olšanská 5, CZ-130 00 Praha 3, Czech Republic, E-mail: Roman.Rak@ct.cz

²Faculty of Special Engineering, University of Žilina, Kukučínova 17, Košice, Slovakia, E-mail: fsi-ke@fsi.utc.sk

³Police Academy of the Czech Republic, Lhotecká 559/7, P.O.Box 54, 143 01 Praha 4, Czech Republic, E-mail: Porada@polac.cz

- *The Safety manager is alone in his position.* He must be able to communicate well and effectively with both his subordinates, members of senior staff, and suppliers of different technologies, and he is permanently solving conflict and sensitive situations. A number of activities are carried out with a certain degree of confidentiality. Great deal of responsibility is put on the safety manager and sometimes he even does not have sufficient means to carry out safety arrangements to the extent the situation, the theory or his own ideas demand in order to bear the responsibility. A level of responsibility with regard to a risk may not necessarily correspond with rights or means which are available to a safety manager. The safety manager is expected to be highly loyal, reliable and confidential. A situation may occur where he will be influenced by the top management in contradiction to his mission. Frequently top management can represent a high risk for an entity (i.e. the loss or theft of sensitive information), because they cannot or will not comply with some basic principles of safety. Additionally top management is sometimes even deliberately trying to circumvent controls due to a number of different reasons (the feeling of power and invulnerability, or in some extreme cases even collaborating with third parties, or deliberate abusing of own power for personal gain). If this is the case for somebody naturally the safety manager will be in his way and will become his enemy. To bear the burden of some findings and not to share them with a third party (including a partner,

family, friends) is no trivial task for the safety manager either. In some extreme cases (state security bodies of operative character) safety managers are required to hide their civil identity from colleagues, friends or acquaintances, and at the same time are made to use a legend of a different employer and profession, and they even have to conceal their real job from their families. Professional deception and a number of means to support the so called "cover-up" are used. It is very demanding for psyche of a safety manager to be able to live life "two ways".

- The globalised world, *the environment* and the institution where safety is carried out, are currently *very dynamic, often uncoordinated, uncertain and chaotic*. With a number of changes undergoing (competitive, strategic, organisational, personnel etc.) which are accompanied also by negative emotions of employees, labour fluctuation is frequently seen. Any instability reflects on safety arrangements negatively, and it is absolutely crucial to be able to react in time, in an adequate manner, and optimally to comply with current trends and situations.
- The safety manager must be *prepared to perform his duty in all circumstances*. He can himself become the object somebody else's interest, therefore a strong personality and integrity is demanded. His personal characteristics, behaviour and both professional and private history must not make him vulnerable and governable. No potential reasons should exist so he can either be blackmailed or compromised. The safety manager must be ready to

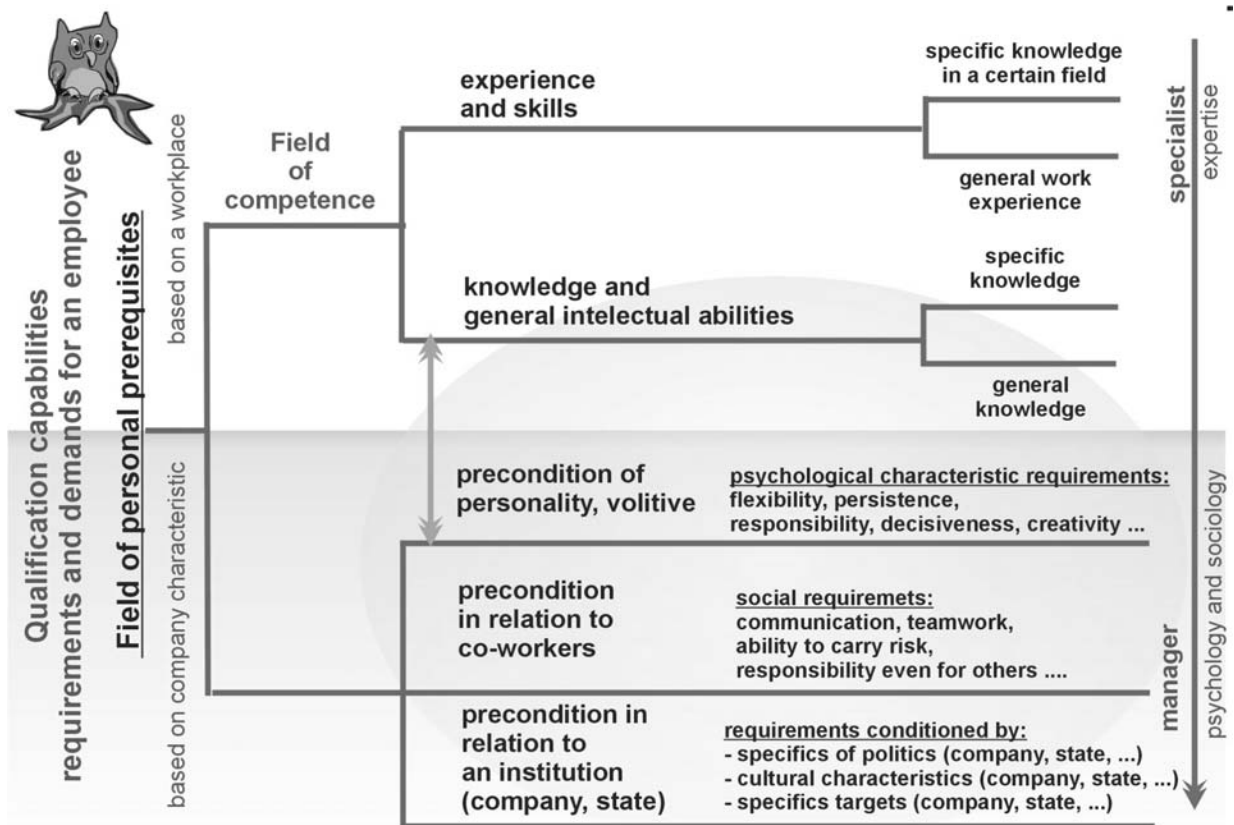

Fig. 1. Requirements and demands on (safety) manager.

be resistant to large number of personal attacks due to different reasons, and deal with them in a sensible way. At the same time he has to take responsibility for number of risks. The safety manager should be able to learn the professional philosophy that either he is checking or testing somebody/something, or he himself is the subject of control. For that very reason he has to be able to work transparently with regard to superior controlling bodies.

- *Unclear Authority.* The safety manager frequently does not have clearly defined authorities in his work, resulting in professional clashes inside the company which have to be sensitively and sensibly solved. The boundary between IT security, personal and general security and mainly between internal audit bodies, risk management etc. is not always clearly drawn. Conflicts may arise in companies where more professional players happen to work on safety without rules being determined which has a negative impact on safety globally. Internal frays occur in organisations at the expense of meeting the primary task – secure safety.

2. The Qualification requirements and demands on a safety manager

For better understanding of requirements and demands on a safety manager it is useful to divide the qualification requirements into several logical categories, as shown in Figure 1. The authors are following the theoretical, basic qualification capabilities of any employee, who then will be a subject of discussion and comparison with specification of the safety manager work.

2.1. Field of competence

When discussing the work of a safety manager we frequently come across a question as to what extent (expressed in percentage) this is a managerial position or the position of a specialist. In literature [11] we can find a ratio of 60:40, i.e., managerial activities constitute 60%. We have the opinion that such a ratio cannot clearly be set, although the title of safety manager encourages us to think that it is mainly managerial work (i.e. “at least 50%”). However, more important is the current position of a safety manager in an institution, his place in the organisation, what his responsibilities authorities are, how many direct subordinates he has in his safety department, how he cooperates with the company management or the company staff. Depending on the various models described above of the position of the safety manager in organisational structure, and depending on his duties it is obvious that in extreme cases the safety manager can be from an IT specialist background (the model of minimal technological safety) with minimal managerial activity, to managerial positions (the model of extensive institutional safety), where almost 100% of the activities of the manager is focused on cooperation and coordination between different experts, employees, management and shareholders of the company.

In this contribution we will not analyse the required experiences and skills, knowledge of the safety manager – the requirements

derive from the institution itself. In the field of IT, it can be for example knowledge of different network protocols, coding algorithms and technologies, firewalls, databases etc. Generally applied it can also include security of buildings, different procedures when protecting data from defensive (competitive) intelligence, personal security etc.

2.2. The field of personal prerequisites

Human personality is complex from the psychological point of view. Personality can either have or not have strong characteristics. Psychology of personality is therefore focused on the analysis of the whole, and on determination of the characteristics.

When analysing the personality of a particular human being, we usually seek an answer to the question of what he is like. We try to find his psychological characteristics, where he is similar and where he is different from the other people, what he can do, and what and how he achieves.

The term personality comprehends that our behaviour and cognition in its various shapes and sizes, has a whole cohesive character and nature. In any moment of happening “I” is active inside of us into which the results of our activities are integrated. That is how personality guarantees continuity of cognition over time.

The term personality therefore reflects the whole, integrated character of psychological activity. The second crucial feature is uniqueness. Personality of a human being is always unique. From the psychological point of view there cannot be two people with identical personalities. Whilst we know doubles in terms of physical similarity occur, from the psychological point of view unity of mental parameters is ruled out. In practice it means that nobody thinks exactly in the same way as “I”. Psychological understanding of uniqueness clarifies the following known assertion that each person in some respects:

- is the same as everybody else
- is the same as some of the others and at the same time in some respects ...
- is different from everyone else.

The whole set-up of mental activity is in this sense unique and unrepeatable.

Personality has a number of definitions in psychology. Through different terminology the base of the following term is explained: personality is understood to be relatively stable composition of biological, psychological and sociological characteristics joined in a unique process of mental activity, which each of us experiences as our own “I”.

For an evaluator or external observer our personality represents an individual and unique “mix” of common and perhaps less common, abilities and characteristics. Now we come to the question what the personality of each human being consists of. Professionally speaking it is an issue of structure or composition of personality.

The issue of a structure of personality can be explained by a simple example. It is known that different people behave in the same situation in different ways. For example following criticism from a boss some might respond by rejecting the reprimand, some might blame colleagues for the mistakes, and others might use family members as an outlet. The differences in their monitored behaviour can be explained by their different personalities, i.e. the difference in the structure and dynamics of personality.

In order to be able to understand how individuals vary, it is necessary to divide personality into components. The differences between people are caused by what components of their personalities are represented, and at the same time how strongly each component is shown. Dividing personality into partial components and their mutual relations set the basic problems of a structure of personality.

The structure of personality reflects what is from the psychological point of view permanent, and also what characteristics only express themselves in certain situations. It means that we usually judge personality according to an individual's behaviour. It is

important to bear in mind that only a certain part of personality can show in each situation.

We know the impact of a situation from our own experience. Each of us can be friendly, but also cold and unpleasant. What pattern of behaviour is shown depends upon situation. To a person whom we want to attract and win favour we can be almost adorable. On the other hand, to a person we dislike and who annoys us with his presence, we can be reserved, short and irritated. The situational variability of our behaviour is natural. At the same time neutral interactions with others result in a typical behaviour from us e.g. friendly and open, or rather reserved and restrained. We talk about a disposition or characteristic which is typical for individuality. Personality structure means relatively stable characteristics of personality which are of a dispositional nature. The structure of personality creates an individual base for behaviour and experiencing, which is updated depending on the situation.

The term personality structure assumes dividing of the psychological whole, i.e. splitting the unified personality to bounded,

Requirements for the position of a safety manager	
Personality and volitional requirements for a safety manager	
<p><i>Problems solving</i> The safety manager should show good analytical skills, healthy judgement and appropriately judge all necessary circumstances:</p> <ul style="list-style-type: none"> • Clearly identifies the task; • Demonstrates clear understanding of a problem and the relating issues; • Analyses problem clearly and with necessary explanation; • Is able to determine the core of a problem and key points; • Considers all essential information; is able to obtain information independently from different sources, is unbiased when verifying the information, analyses; • Healthy judgement; • Shows a well organised, planned and logical approach; • Is independent when solving tasks and problems. <p><i>Decision making</i> Shows ability to foresee, makes realistic decisions based on available sources and is willing to take responsibility for his decisions:</p> <ul style="list-style-type: none"> • Makes decisions without necessary delay, which are clearly articulated; • Decisions are supported by obtained information and facts; • Foresees and considers both short and long-term impact of his decisions; • Sets priorities. <p><i>Creativity</i> Shows innovative approach and originality when responding to a problem and is flexible when assessing progress of action:</p> <ul style="list-style-type: none"> • Keeps a flexible approach; • Initiates alternative procedures; • Willingness to accept new thoughts, action plans and decisions; • Shows innovative, original or lateral thinking (using unusual relations) • views issues and problems from a broader perspective, has a sense of detail but does not get buried in it; • is a visionary, is able to formulate strategic visions and targets in given area of responsibility. 	<p><i>Persistence, self-motivation and motivation of others</i> Submits solutions in a way which persuades others about acceptability of the solution:</p> <ul style="list-style-type: none"> • Persists and does not yield in effort, when coming across to resistance; • Shows high level of motivation, interest and involvement in problem solving; • Is able to motivate others and raise trust. <p><i>Coping with burden</i> Constructively reacts to frustration, able to accept criticism, keeps calm and knows how to deal with multiple problems at the same time:</p> <ul style="list-style-type: none"> • Constructively reacts to a failure or frustration; • Can cope with multiple problems at the same time; • Stays calm, under control and considers coolly; • Can avoid exaggerated reactions; • Remains tolerant in conflict situations when facing resistance: <ul style="list-style-type: none"> • assertive; • can accept constructive criticism; • effectively utilises time. <p><i>Integrity</i> The safety manager's career has up to now been exemplary, cannot be challenged from the trust and reliability point of view. Any preconditions for blackmail, dependency, influence are absent:</p> <ul style="list-style-type: none"> • has a clean record; • does not take addictive material (drugs, alcohol etc.); • lack of risk dependency upon money (debt, hazardous games, ...). <p><i>Personal charisma</i></p> <ul style="list-style-type: none"> • is both socially and professionally recognised, or is recognised by senior and middle management, by his direct colleagues.

Requirements for the position of a safety manager	
Pre-conditions with regard to his colleagues	
<p><i>Communication skills</i> The safety manager is able to communicate clearly and concisely both orally and in a written way, takes other's needs into consideration. During the selection procedure he has to demonstrate:</p> <ul style="list-style-type: none"> • clear and suitable language; • appropriate usage of vocabulary, stylistics and grammar; • thinks before starts speaking or writing; • his language makes him to be completely understood; • chooses communication which fits best to a type of a receiver; • is able to avoid jargon and slang; • is able to communicate in complicated critical situations. <p><i>Interpersonal relations</i> Is open to opinions and wishes of other people and is able to cooperate with them. Is tactful and diplomatic:</p> <ul style="list-style-type: none"> • Is able to show tact and diplomacy when dealing with other people and when solving problems; • Show understanding, perceptiveness to opinions and feelings of other people; • Is interested in impact of his words on other people; • Develops work cooperation with other people. He is a team-player and can also lead a team. Is able to cooperate in a team; • Avoids prejudice and dogmatic opinions. 	<p><i>Presentational and educational skills</i></p> <ul style="list-style-type: none"> • Presents thoughts, action plans and decisions in persuasive manner; • Is able to sale himself, his team, organisational unit, a problem which is a subject of a solution; • Is able to use different technologies for presentation; • complex and technical issues can explain clearly even to non-professionals; • is patient; • very good written skills, can create clear and concise binding documents.

Requirements for the position of a safety manager	
Preconditions with regard to an institution	
<p><i>Representing the employing institution and identification.</i> The safety manager creates a positive impression of an institution, identifies with the company mission and ways it is enforced.</p> <ul style="list-style-type: none"> • Permanently gives positive impression; • Is loyal to the institution; • Is loyal to mottos, culture and the company ethic. 	

relatively independent components. There are different opinions in psychology as to what components create a structure of personality. Individual approaches vary mainly in number and type of components identified.

The basic requirements for a safety manager (according to Figure 1) are summarised in the three tables below with the following break-down.

The requirements for a safety manager are mainly based on the mission of a company and can vary from institution to institution. Examples of entities with different requirements would be: a) a smaller company owned by a Czech owner; b) an international company, where any relation to the Czech language, culture, religion, political affiliation might be totally suppressed; c) state security bodies (requires an indifference to politics, the protection of Czech interests and the interests of coalition partners or allies) d) security bodies of political parties (which requires a positive approach and loyalty to certain politics etc.).

3. The issue of identifying personality

Identifying the personality of a particular person is the touchstone of psychology. It verifies the relation between reality and its psychological reflection. If we describe the personality of a person, it allows us to some degree to predict his behaviour in different situations. The more exact the description of personality the more precise the prediction of behaviour. It is mainly useful for two purposes:

1. To understand behaviour/actions which already took place (i.e. to understand inner motives of a surprising action or to allocate certain behaviour to his probable originators). In the case of safety managers it can for example help us to understand why up to now a reliable and loyal manager has committed a misconduct, or to identify who initiated an incident, who was the leader and who was only following.
2. To estimate and predict human behaviour (e.g. to select the best candidate for a managerial position etc.).

In both cases our assumptions on personality are based on observations on how individuals appear.

Rather than looking for personality characteristics and more permanent features which represents a list of general characteristics of an "ideal" manager, we regard an *interactive, dynamic approach to a specific personality of manager* as more appropriate. *In requirements and profiles, models for professions are frequently set at unrealistic levels, often supported by empty, general terms such as reliability, flexibility, loyalty, creativity (what about if he is "creative" against the interests of the company?).*

Supposing for some reason a manager loses motivation to be loyal to his employer at that moment all his original positive characteristics and abilities required at the selection process work against the employer. Additionally we have to bear in mind that loyalty and reliability is not something necessarily something permanent – they have to be fostered, strengthened towards the company. Even the most loyal employee is bribeable, it is just a question of price. The preliminary psychological examination, consisting of psychological methods and procedures used in clinical practice, provides only introductory data and information on dispositions, which have to be continuously verified and revised. Possible changes have to be monitored and evaluated – this is the purpose of forensic psychological audit.

The psychological foundation of this approach and tools leading to identifying personality, identification and understanding of *standpoints*, which an individual takes in *real working and managing situations* (mainly in conditions of increased psychological burden). It mainly concerns the standpoint of an individual *towards other people* (relationally important people, and through them to the reference groups and to the whole society), *towards the performed work, including the conditions, under which the work is carried out* (and towards the institution and its targets) and towards himself (which reflects self-reflection and self-estimation), *towards situations*, which he is in.

Cognitive, emotional and conative ability to act certain way is reflected in standpoints. Cognitive processes bring information/knowledge. In emotions we experience their significance. In standpoints, which integrates cognitive and emotional aspects of psychology, we take *value relationships* towards objects, i.e. we allocate certain value, they either appear desirable or undesirable, good or bad.

Anticipation is present in each standpoint – i.e. assessing assumed effect of activities. A standpoint is not just a subjective reflection of reality. It closely relates to self-reflection of a human being. We create standpoints on the base of knowledge of reality and at the same time it corresponds to what is desirable for us.

Generally, standpoints determine the way of behaviour, they are consistent with behaviour if the situation allows that. Standpoints set the foundation for certain conative readiness, whose appearance in action depends upon situational conditions. In the cognitive part of standpoints, which is crucial condition for any performance, appear the ability and motivation of an individual.

4. Requirements for a personality of safety manager

Determination of personal prerequisites has to derive from specific activities performed on a position of a safety manager (in order to meet the framework of social-professional role of a safety manager) in specific institutions.

4.1. The main activities carried out by a safety manager

The main activities carried out by a safety manager are particularly:

- the creation of a concept and system of safety measures in institutions (plans, arrangements etc.) ;
- activities on prevention (precaution) and detecting of events jeopardising internal and external safety of institution, information safety;
- the analysis of threats, identifying risks, risky positions (cooperation with the HR department – tests of people on from safety point of view sensitive positions);
- controlling activity;
- investigation of extraordinary events (information leakage, system violation, material and financial damage etc.);
- proposal, introduction and implementation of adequate and timely, proactive measures;
- educational activity;

4.2. Requirements for a personality of safety manager:

- *Abilities and motivation of individual* we consider personal qualities to be crucial (abilities – shown as professional skills, social – dealing with people, motivating them, setting tasks, assessment etc. The motivation field also reflects values which an individual appreciates).
- As with any manager, *the core of his activities is to deal with information*. It includes the ability to obtain, process, analyse, use and protect information.
- In comparison with other managerial positions which involve dealing with information, it is the *character and content of information, the way the information is obtained and how it is handled and used* which makes the safety manager different.

Key skills are required for the work of safety manager, which have the following structure:

Social skills:

- Ability to work in team
- cooperation
- ability to face conflict situations
- communicativeness

Skills relating to the own person:

- competent dealing with himself, with his own value
- self-reflection
- purposeful development of own values of image
- ability to assess myself and to develop further

Skills in the field of methods:

- systematically focus on targets by applying professional knowledge,
- form creative solutions,
- structure and classify new information,
- put things into context, learn about relations,
- critically review in order to achieve innovation,
- consider opportunities and risks.

Skills consist of different abilities and their mutual influencing. They are obtained in a reflexive way. In practice mainly the following abilities are required from a safety manager:

- *Communication and cooperation* – the ability to communicate and actively contribute in group processes in an original manner.
- *Problem solving and creativity* is the ability to identify problems and solve them creatively.
- *Independence and performance* – the ability to independently plan, carry out and control the progress and results of work.
- *Responsibility* is the ability to accept joint liability.
- *Thinking and learning* is the ability to further develop the process of learning and thinking in connections.
- *Line of reasoning and assessment* is the ability to factually and critically assess the results of one's own, joint and other people's work.

These skills are not isolated from each other but create a harmonic whole.

5. How to look for and select a safety manager

The number of qualities of a safety manager is generally similar to required characteristics for a selection of an excellent and successful manager in any other field.

The US weekly Business Week evaluates the best and the worst managers of large international companies. Detailed analysis established the following criteria for determining the "longevity" of a safety manager, i.e. how long he can remain in his position and meet the interests of shareholders, not to fail their trust, reveal at least the following three and main criteria:

1. High IQ and emotional quotient;
2. Professional qualification
3. Long-term experience in managerial positions

Further essential criteria according to the US weekly are creativity and ability to bear great risk. It is an interesting fact that even on other positions we do not find the criteria of honesty.

Readers surely expect that when filling the post of a safety manager, a large number of specific principles must be observed. It is useful to bear in mind that the following principles for good personnel work with the following aspects mainly apply:

- The safety manager is selected as any other manager, i.e. we pay attention to the usual requirements for such position during selection.
- We consider aspects relating to specifics of his safety career history in our institution (company).
- The objectives, mission and position of an institution on society, the state or on the market, culture or inter-personal relations in a company etc. have an impact on safety policy in a company, and therefore on the setting of specific requirements and consequent selection criteria for the work of a safety manager. The criteria can be unique, different from any similar practice in other companies.
- The future place of a safety manager in the hierarchy of an organisation, the demands on him and the skills he possesses in order to meet the demands are also crucial.
- Great attention should be paid to the motivation of a safety manager. We cannot judge motivation only from the stand-point of recruitment – it should be monitored throughout the career. We should secure such conditions that the safety manager works loyally for the benefit of the institution, and we should also try to reduce personnel fluctuation, which represents a great risk from the safety point of view.
- We have to work with the safety manager, to motivate him, to give him space for personal development, allow career growth an overall satisfaction.
- It is recommended to carry out forensic audit (see further) with the aim to find all the risk factors of personnel characteristics.
- We have to bear in mind that sufficient time and finance has to be paid when selecting a safety manager. When filling a position of safety manager in a small organisation which is just starting to get involved in safety, one alternative is to recruit a person without the necessary safety knowledge and qualifications (while meeting the other required criteria), and subsequently securing his growth in the professional security field. When filling the position of safety manager in a large company it has to be a professional person with adequate experience, and it is essential to credibly assess the experience. It is common to check references, and in State institutions to perform operative safety tests, which can take months and are usually confidential. The effort costs a lot, therefore we have to be clear what tasks the safety manager will have in the institution.

References:

- [1] MATOUŠKOVÁ, I., RAK, R.: *The role of the safety manager when enforcing comprehensive information security, 5th International Conference Information Security Summit, 2004, pg. 85-98, Tate International, ISBN 80-86813-00-2*
- [2] MATOUŠKOVÁ, I.: *Psychology and tactics of security investments driving in business sphere (in Czech), Security Magazin, č. 4/2004, pp. 48-49*

- [3] RAK, R., MATOUŠKOVÁ, I.: *Creative barriers, part I. - Security, human intellect and influence of social environment* (in Czech), DSM 3/2004, pp. 26–28, Tate International, Praha
- [4] RAK, R., MATOUŠKOVÁ, I.: *Creative barriers, part II. - Security, emotion and interpersonal communication* (in Czech), DSM 4/2004, pp. 28–30, Tate International, Praha
- [5] RAK, R.: *Homo sapiens as the most powerful and fragile segment for retrieving and securing of information* (in Czech), DSM 4/2002, pp. 10–13, Tate International, Praha
- [6] BRABEC, F. et al.: *Safety for a company, institution, citizen* (in Czech), Public History: 2001, ISBN 80-86445-04-06
- [7] ČÍRTKOVÁ, L.: *Criminal psychology* (in Czech), Praha: Eurounion, 1998, ISBN 80-85858-70-3
- [8] HALL, C., S., LINDZEY, G.: *Psychology of personality* (in Slovak), Bratislava: Slovenské pedagogické nakladateľstvo, 2002. ISBN 80-08-03384-3
- [9] JANÍČEK, P., ONDRÁČEK, E.: *Problems solving via modelling* (in Czech), Brno, Vysoké učení technické, 1998, ISBN 80-214-1233-X
- [10] KOHOUTEK, R., ŠTĚPANÍK, J.: *Psychology of work and management* (in Czech), Brno: Akademické nakladatelství CERM, 1999, ISBN 80-214-1552-5
- [11] KULAJOVÁ, T., HALOUZKA, J., SEIGE, V.: *Genesis or How safety department is created* (in Czech), DSM, No. 2, 2001, pp. 32–35
- [12] MIKULÁŠTÍK, M.: *Communication skills in practice* (in Czech), Praha: Grada, 2003, ISBN 80-247-0650-4
- [13] MITNICK, K., SIMON, W.: *The Art of Deception: Controlling the Human Element of Security* (in Czech - translate from English original), Praha, HELION S.A., 2003, ISBN 83-7361-210-6
- [14] SPURNÝ, J.: *Psychology of interrogation* (in Czech), Praha: Portál, 2003, p. 114, ISBN 80-7178-846-5
- [15] *Analysis of information safety in the Czech Republic 2003* (in Czech), Praha, Ernst & Young, DSM, NBÚ, 2003, ISBN 80-902858-8-0
- [16] MATYAS, V., RAK, R., RIHA, Z.: *Biometric Authentication - Trends and Vision, Information Security Summit 2002*, pp. 66–90, Prague, ISBN 80-902858-5-6
- [17] PORADA, V., NEČAS, S.: *Bank security as the part of institution security policy* (in Czech). *Bezpečnostní teorie a praxe*, zvl. číslo, Praha: PA ČR, 2001, p. 437–448.

Leszek Korzeniowski *

SECURITOLOGY – THE CONCEPT OF SAFETY

In the article the author presents his own definition of the category of safety, emphasizing both: objective and subjective aspects of this idea. The author, on the basis of available publications, carries out the presentation of securitology as the scientific discipline as well as categories studied within that science, like: security, needs value and sense of safety, risk, danger, personality of a manager, etc. In the article are included proposals of a security model covering objective dangers and the sense of safety.

Key words: securitology, security, science of safety

1. Aims of the article

The aim of the article is to review science accomplishments and to present relationships between objective and subjective categories of safety as well as to propose the author's own definition of safety and concept of safety model.

2. Research problems

Safety understood as a certain state based on the lack of threat is the subject of interest for many research areas, like: natural science, technical science, medicine, agriculture and social science, as well as particular scientific disciplines with roots reaching the very beginnings of the scientific studies of reality. It is also a practical knowledge derived from many different areas of business activities and every-day life.

For each scientific discipline encompassing more specific research areas within it it is possible to ascribe representatives of these disciplines, their standpoints and publications regarding safety.

First publications undertaking the task of recognizing *securitology* as a scientific discipline – concerning the problem of safety, date back to the year 1989 – which can be explained by new requirements, expectations and conditions, created after the revolutionary changes of socio-political regimes in Europe. The characteristic feature of these publications is a multidimensional way of perceiving and understanding safety as a subject of research, resulting from the observation that the interactions of threats depend on many different factors, both: objective and subjective, sociopsychological and cultural, political and legal, natural and technical, macro- and microeconomic, remaining in mutual and solid connections

The term: *securitology* (*siekhuritologiya*) was used in the year 1989 in Russia by W. I. Jaroczkin [5] who, in a very innovative manner, pointed at the new scientific discipline being separated

from others, the new science about the safety of human life. Among other authors using the word securitology in regard to the science treating safety as the social aim and the subject of research as well as employing adequate research methods, are: Ulrich Beck, Jan Buzalka, Tadeusz Hanausek, Victor Porada, Janusz Swiniarski, Stanislaw Piocha, Leszek Korzeniowski, Jan Mikołaj, Ladislav Šimák, Ladislav Hofreiter, and others.

Tadeusz Hanausek uses the concept: "science about the administration of safety" and emphasizes that "whenever thus exists a possibility (at least theoretical) to minimize or eliminate threat by purposeful, regulative human interactions, then the management of safety (opposite of danger or threat), is possible and advisable. Furthermore, since this type of management is possible, it should be based on theory, so the science of safety management should exist and develop [3, p. 37].

The University of Zilina (Slovakia), prefers the name of *Security Management "Bezpečnostny Manazment"*, by which "the specific intellectual activity, directed to reverse or to minimize risk or threats of various nature-regarding life and possessions of citizens, groups and society, is being understood that employs elements of risk management, crisis management, disaster (accident) management, values management" [12, p. 20].

Risk exists here as an auxiliary notion, by some authors it is considered to be a form of threat or danger itself. The research concepts of this university directly point to the substantiality and measurability of risk, thus treating the risk as the measurement of threat, expressing the potentiality of danger. Such understanding of risk gives the possibility of risk management category of "uncertainty" characterized by the lack of possibilities to indicate alternatives and their validity. And thus, Ladislav Šimák defines the risk as "quantitative and qualitative expression of danger, degree or measurement of threat. It is the probability of formation of the negative phenomenon and its results" [14, p. 39]. On the other hand, Jan Mikołaj writes: "Risk as a rule is defined as something unsteady, uncertain - what is bound up with the course of the phenomenon and that disturbs its intentional causation" [13, p. 17].

* Leszek Korzeniowski

European Association for Security, Śniadeckich 12 B, 31-531 Kraków, Poland, E-mail: lfk@pp.com.pl

Ulrich Beck described a *risk society* as the one endangered by side-effects of a scientific and technical development. At the same time, conclusions can be drawn that these are not only health consequences for people or nature but as well, *social, economic, political side-effects of these side-effects*: Market crash, capital devaluation, bureaucratic controls of business enterprises, opening of new markets, gigantic costs, court proceedings, loss of reputation. In the society of risk, gradually or stepwise – by an alarm warning about the smog, an accident with a poisoning substance, etc. – a *political potential of a catastrophe* is being created. (...) The risk society is a society of *catastrophe*. What threatens it is that “an exceptional state becomes the norm” [2, p. 33]. This is how Ulrich Beck, in a most precise way, described the nature of connections: safety – threat – risk: “ (...) risk society. Its normative antiproject that lays at its basis and drives it is the *safety*” [2, p. 64]. The normative antiproject of *safety* is *non-safety (threat)*.

Based on the analysis of literature and the scale of dangers threatening a person, conclusions can be drawn about the lack of sufficient theoretical basis in the area of needs, values and subjective sense of safety of individuals, social groups as well as humanity. It also appears that in spite of advances in the sciences of physics, geophysics and others, as well as in spite of the enormous progress in technique and technology, the objective state of safety has not still been developed enough nor is sufficiently predictable. Earthquakes, *tsunami*-waves and other elements still engulf thousands of victims among people and cause immense losses in their property.

If it can be acknowledged that the research of certain categories has contributed to a marked decrease of loss or even control of threats (for example, the category of risk in banking), it also has to be said that the problem of the objective category of dangers and the sense of safety still require further research and exchange of scientific ideas among various scientific centers from all the continents, and especially from Europe.

3. Securitology - the concept of safety

Science is a highly specialized exploring activity conducted by scholars and aiming at objective exploring and understanding the environmental and social reality and at creating premises for using the acquired knowledge in order to transform the reality in accordance with human needs [11, p. 12].

Security apprehended as a state of lack of risk, is a subject of interest of many areas of science such as natural, technology, medical, agricultural, social and also particular scientific disciplines dealing with ancestry reaching the beginnings of scientific recognition of reality.

Safety means a certain objective state understood as a lack of danger, sensed subjectively by individuals or groups [6, p. 183; 9, p. 21; 10, p. 437]. It should be noticed that the world: “state” is very closely related here to the concept of situation which describes the configuration of common relations between humans and other elements of their environment within a certain period of time.

When analyzing this kind of relation from the point of a human (who is one of its elements), we can say that the “state” means here that the subject of the situation may also be non-human.

Victor Porada defines the state of safety as a system of bound up together and interdependent to various degrees factors and their characteristics that decide about the health, the life and all other values in a certain society (form of government, freedom, faith, property, etc.) [19, p. 263]. Negative phenomena are, as a rule, described and penalized in the country’s legislature.

The meaning of the word “safety” is related here to the subjects marked by this title (designators of this title). The entirety of these subject (designators) constitutes the range of the name. The word: “safety” is derived from Latin: *sine cura (securitas)* [22, p. 27] and in contemporary dictionaries it means: “the state of non-threat, calm, certainty” [20, p. 147] or: “the psychological or legal state in which an individual has the sense of certainty, support in another person or in the proficiently operating legal system; the opposite of threat” [21, p. 50]. Thus, the designators of the concept of “safety” are the set of contradictions to “threat”.

Threat is a potential reason of an unwanted state. Threats are not the category by themselves because they always relate to a certain subject to which they apply their destructive character. They may cause negative consequences because each subject (a person, a system, an organization, the vastness of nature), is characterized by a lower or higher susceptibility, certain weaknesses that make it possible to change a potential threat into the harm.

For the purpose of generating threats, certain possibilities are necessary which are contained in the subject itself, in its surroundings or in the relation between the subject and his/her surroundings. This kind of threat can be characterized by a *negative potential* (destructive, threats), understood as an ability to destructive reaction to the system.

Victor Porada emphasizes that the state of safety bound up with the environment, in which it is created, progresses and develops further. The environment may have a character such as: geographical, social, political, etc., or the combination of these. The sources of threats and conditions of the environment determine the state of safety, circumstances have rather accidental character and may, but do not have to, influence the course of action directly [19, p. 263].

The definitions of safety concept concentrate on its objective and subjective aspects.

- **The objective state of safety** relates to the existence or nonexistence of real threats independent of anybody’s perception. These will be the threats caused by:

1. **inanimate nature** independent of a person (for example: space objects, Earth’s tectonic plates movements, volcanoes, typhoons),
2. **animate organisms** (microorganisms, plants and animals),
3. **human products** (for example: buildings, machines, equipment, chemical substances, explosives),

4. **human** and society (tensions in interpersonal relations, conquests, slavery, religious wars, terrorism). It may be real activities of other participants of social life, unprofitable and dangerous to the vital interests and the basic values of an individual, a group, a society or the whole mankind.
- **The sense of safety** is the expression of a subjective aspect and relates to the consciousness of existence – the lack of it or the lack of awareness of any possible contraction to the danger.

4. Model

In reality, we often come across a situation in which the individual's behavior even if agreeable with the perception of reality, and not with its objective features, results in objective features and not perceived or imagined ones. Modern technique of registry has shown tragic situations being such a problem (26th of December, 2004 – following the earthquake in the nearby of the Indonesian Island of Sumatra, a gigantic *tsunami*-wave was created. The number of fatalities was estimated at over 300000, wounded at a few millions. It was perceived that the environment was friendly, safe.

The essence of this situation is the fact that people were facing the threat that they could not see, but which existed in reality).

The objective features shape the person's behaviour depending on how he/she sees his/her situation while the understanding of a situation by an individual depends on:

- what the objective features of the environment are,
- what his/her own characteristics are, and
- what course of action he himself/she herself takes.

Furthermore, certain elements of a situation influence a person directly, without the intervention of an individual's consciousness, for example if, estimating the situation as being safe he/she will not react then he/she will be hurt accordingly to the objective characteristics of the threat and not the imagined features of the environment.

References

- [1] BUZALKA, J.: *Certain problems of the crisis management theory and the civil security*, (in Slovak), Akadémia Policajného zboru. Bratislava: 2001.
- [2] BECK, U.: *Society of risk. On the way to a different progress*, (in Polish), Wyd. Naukowe SCHOLAR, Warszawa 2002.
- [3] HANAUSEK, T.: *The safety management - a new branch of science*, (in Polish), Bezpečnosť a ochrana majetku, LIPORT LFK, Kosice 2001.
- [4] HOFREITER, L.: *The safety management*, (in Slovak), FŠI ŽI, Žilina, 2002.
- [5] JAROCZKIN, W. I.: *Securitology - the science of life safety*, (in Russian), Moskva 1989.
- [6] KORZENIOWSKI, L.: *Management. Fundamentals of administration*, (in Polish), EAS, Kraków 2003.
- [7] KORZENIOWSKI, L.: *The safety management*, (in Ukraine), Aktualni problemi ekonomiki 2004, No. 1(31), 147-154.
- [8] KORZENIOWSKI, L.: *The safety management*, (in Polish), Gumanitarna paradigma osvitnych ta ekonomicznych procesiv u svitli koncepciji evropejskoj bezpeki, REGI, Rivne 2002, 68-77;
- [9] KORZENIOWSKI, L.: *The safety management. From a risk to the system*, (in Polish), Zarządzanie bezpieczeństwem. Prace Edukacyjne, red. Leszek Korzeniowski, LIPORT LFK, Kraków 2001.

Taking into consideration the relations between the objective and subjective aspects of safety, it is possible to design a model consisting of four segments:

- State of safety** when the external threat is little and is perceived as low.
- False safety** when the external threat is high, but it is perceived as low.
- Threat** (lack of safety) when the external threat is high and the perception is correct (adequate).
- Obsession** when the external threat is low but it is perceived as high.

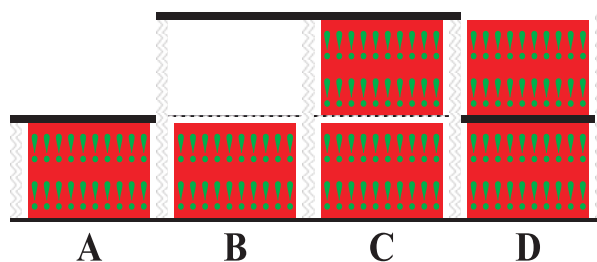

5. Conclusions

The analysis carried out has shown that safety has its objective and subjective aspects. *Securitology*, a new scientific discipline being created, undertakes the research of objective situations as well as needs, values and sense of safety. As results from the undertaken by the author analysis, the sense of safety in the closest surrounding shapes itself differently from the general scale. The author explains this feature with a subjective factor – being intensified by a character of information in mass media (that does not have any influence on the sense of safety in known, personally, local environment).

The proposed safety model, taking into consideration objective threats and the sense of safety, can be useful to describe scientific research and management procedures.

- [10] KORZENIOWSKI, L.: *The safety management. Market, risk, threat, security*, (in Polish), Zarządzanie bezpieczeństwem, PSB, Kraków 2000.
- [11] KRZYŻANOWSKI, L.: *The science of management - the foundation*, (in Polish), PWN, Warszawa 1985.
- [12] MIKOLAJ, J., HOFREITER, L., MACH, V., MIHÓK, J., SELINGER, P.: *The safety management - terminology*, (in Slovak), Výkladový slovník, Multiprint, Košice 2004.
- [13] MIKOLAJ, J.: *The risk management*, (in Slovak), RVS FŠI ŽU, Žilina 2001.
- [14] ŠIMÁK, L.: *Crisis management in public administration*, (in Slovak), Žilinská univerzita, Žilina 2001.
- [15] OLCZYK, E.: *The Poles are afraid of offenders*, (in Polish), Rzeczpospolita 2003-04-14.
- [16] *Social opinion. The world less safe*, (in Polish), Rzeczpospolita 2004-01-09.
- [17] PIOCHA, S.: *Macroeconomy and problems of security*, (in Polish), Problemy bezpieczeństwa ekonomicznego wobec procesów globalizacji, red. naukowa Stanisław Piocha, PTE, Koszalin 2004.
- [18] POLEDŇÁK, P.: *The protection works in municipal agglomerations* (in Slovak), Riešenie krízových situácií v špecifickom prostredí, Žilinská univerzita v Žiline, Žilina 2002, III. 123-132.
- [19] PORADA, V.: *Theoretical analysis of the police information, situation and identification of the police action*, (in Czech), Sborník Poličejní akademie ČR, Praha, 2000
- [20] *The Polish dictionary* (in Polish), PWN, Warszawa 1979.
- [21] *The dictionary of contemporary Polish*, (in Polish), Reader's Digest Przegląd, Warszawa 1998.
- [22] ŚWINIARSKI, J.: *The philosophical basis of safety education* (in Polish), Egros, Warszawa 1999.
- [23] ZIĘBA, R.: *The establishment of european safety*, (in Polish), SCHOLAR, Warszawa 2004.

Jozef MetenĎko *

INFORMATION AND COMMUNICATION CRIME

In this paper the author tries to shortly characterize the content and scope of crime connected with information and communication technologies. He analyses the (known) possibilities to commit crime connected with abuse of information and communication systems. These are registered in the uncovering and clarifying activities performed by police officers. He demonstrates ground conditions under which such crime arise, as well as their specialities. The author points out some possibilities within the crime control, as a practical analysis on the basis of police sciences, law, criminology and criminalistics.

Key words: *crime, information and communication crime, crime connected to information and communication technologies, information and communication system, conditions for origin of crime, possibilities of crime control*

Introduction to an issue

Development of human society is perhaps the most significantly characterized by the development of new technologies. Automated data and information processing have been developing and penetrating into all spheres of social life. The same significance is put as well on their transmission, mainly as a tool of directing complex processes for different, particularly technical areas of life. Fast development of information and communication technology has an impact on all spheres of present-day society. An integration of telecommunication and information system enables the speeding and improves the reliability of information processing, storage and transmission. It is the matter regardless the distance and the way of communication, thus opening a wide spectrum of possibilities in positive or negative directions.

In its positive direction, this development causes and backs up huge economic and social changes in the Slovak Republic, too. Technics and technology are, in general, created to serve the people. Development of information and communication technologies (ICT - Information and Communication Technology) is very fast. Efficiency of technics and technology is growing, but the areas where they are used are also spreading. At present time one may not find any branch of human activity where he would not meet the electronics and its application. Close future will be typical for a larger and deeper integration of information and communication technologies with other ordinary household and office equipment (television set, telephone, refrigerator etc.). We will be encircled by technologies on our every step and still in a larger extent. [13]

Jobs and free time performances depend, each day to a larger extent, on the right, reliable and unstoppable work of complex computer and communication systems. Information and communication technologies started to create a *new form of conduct of individual subjects in economic and management spheres*. These technologies have a significant influence on our everyday life. Development is so fast that observing new information is a need;

otherwise a huge gap between reality and knowledge arises. Information technologies *expand very fast even into ordinary life* and at the same time a fast development in the area of technologies themselves is in the process.

We may claim that the phenomenon of crime has social features, and is directly connected to the development of society, people. Without any doubts we may claim that as the development of human civilization reaches different levels in different societies, as well crime development has its drawbacks and peculiarities and its development is not directly connected to a human progress. Knowledge of criminology and crime development in Slovakia shows that democratization trends within social relations lead to their clearance but simultaneously to the increase of crime [4]. Consequently, the safety is being worsened and investments into protection and safety are significantly growing, logically by the use of modern technologies and technics. We dare to state our third premise on the issue of mutual contingency of the progress of human society and its structure towards "development of crime technologies". It is so because technologies and technics in every human activity are used not only in a positive sense, but also fully naturally for negative and condemnation worth goals. Neither technics nor technologies do have the possibility to choose the result and the way of how to reach it. Such feature is typical only for a man as a creator and at the same time abuser of stated "tools for improvement of life".

Criminogenic factors

Technology and technics are and will remain *the subject and tools* of interests, which overcome the boundaries of allowed and belong to the area of their misuse. Certainly, to deal with it, it is not always necessary to be it the matter of crime. On the other hand, new and not used or unknown technologies as a tool or means of activities cause the doubts whether the act is criminal or due to various reasons able to be recourse-able or still allowed. It

* Jozef MetenĎko

Department of Criminalology and Forensic Science, Police Academy Bratislava, E-mail: metenko@minv.sk

is *non-existence of relevant regulations* within Criminal Code that causes and may cause doubts about a criminal act, or – namely in the area of protection of social and ethic norms, about a need and possibility to bring other sanctions for such activity.

Regardless other human activities, *expanding development of communication and information technologies* has its shadow side, too. This is featured by new forms of crime as well as by traditional crime committed via new technologies. Technological expansion causes the fact that the consequences of criminal or other anti-social activity are hardly recourse-able.

Among the *reasons of its non-recourse-ability* and conditions for the development of such crime belongs mainly the fact that national borders do not geographically limit crime. Current cases of fast spreading computer viruses in the world confirm the fact. One of the main reasons of Internet crime is the feeling of anonymity. Basically, Internet offers anonymity *to everyone*. Also this is the reason why one of the main directions of the development of information and communication crime is Internet crime.

For the development of information technologies, software is the most important form of creative work, usually done with the use of computer. Programs represent one of the most remarkable features of intellectual creative work. Protection of creativity in this area is the goal of international organizations and its legislators' interests are gradually increasing. Simultaneously there prevails a bigger power and higher pressure on *misuse or non-exercising* copyrights for these products. On one hand development is negative – loss of respect to law and work of others, on the other hand it has been over 30 year's journey of intensive impulses on communication and information technologies development.

Existence of new information technologies, computer networks and updated technical achievements enable to reveal crime more effectively, but at the same time they provide, in many cases, space for *non-recourse-able crime*. As a rule offenders are usually *one step ahead of repressive apparatus*. Such statement is the matter of the police in its full extent. Reasons are several. First of all it is a *qualitative and quantitative level of software and hardware equipment*. Furthermore it is the lack of *qualified* experts. Unfortunately it is true that the police does not stand on the same level with the offenders, it is far behind.

Our goal is to *keep such distance to its minimum*. In case of information technologies it is very true. The present puts heavy demands on the police and we may say they will grow. Communication and information crime will grow all the time. Not far is the period when, like today we are afraid of stealing our vehicle or afraid of burglary, we will be afraid of unauthorized gain of data from our personal computer or making our lives unpleasant which is more and more dependable on information technologies, not speaking about personal data security.

New technologies bring new features, functionality and consequently, an added value for a final user. These modern technologies behave at the same time as tools and goals of incorrect use of even abuse what may be in its final form reflected in crime. *Breaking and abuse of ownership rights of owners and holders of license for technologies* in private sector represent diverse and actual form of communication and information abuse. In their working hours, working staff is involved also in other activity than the ones set by the agreement, making use of the employer's technology and thus causing him direct or indirect loss. In these cases law is broken, sometimes only internal regulations are broken. Area of war applications is a separate chapter where information technologies might act as a goal and tools of information war.¹⁾ [12]

Change of content and scope of notions

In the last decade everyday speech, but mainly police language has been using the notion of *cyber crime* [9]. Specialized literature still lacks any theoretical elaboration of traces caused by ICT such as analysis of their classification in the theory of criminalistic traces, what has a tradition in the Slovak and Czech criminalistics. Often we talk about cyber crime and cyber torts but we do not specify them, we do not study their features, ways of their detecting, specifics of their seizing, documentation, analysis and evaluation in details [14]. There is still absence of attempts to sum up all knowledge with an aim to reveal and prove this type of crime and at the same time to have a successful control over it and prevent its further spreading.

The notion of cyber crime appeared at the times of mainframe computers and this area has been fully developed. Nowadays other technologies and means seem to be common and they connect or are suitable complements to information possibilities with communication in various forms. They have a common platform in a digitalization of everything around us.

Every day we use mobile phones, wireless data transmissions from our personal electronic devices (WiFi, Bluetooth), electronic diaries, handlers (personal computers to our palms in a size of cigarette packet), audio digital record devices, digital videocameras and cameras, video and DVDs, credit and identification cards, various record media (CD, DVD, USB keys, digital memories of videocameras and cameras, optic media etc.), rich extras of different types of peripheries to all these devices. There are also co-parts of other technologies – board computers of cars, planes, ships; different safety and monitoring devices, electronic identification of objects, goods, etc. All these and many other objects may be the subject, object and goal of criminal acts.

From the viewpoint of criminalistic and forensic research all these devices leave traces of their activities having general and individual features and which are usable in practice. After our

¹⁾ Murdza, K.: ISBN 80-8054-325-9. s. 110-111. unlike Jašek, R.: Bratislava: Akadémia PZ 2004. ISBN 80-8054-325-9, 104-108. alike Cul'ba, M., Felcan, M., Gýmerská, J.: Bratislava: Akadémia PZ 2004. ISBN 80-8054-325-9, p. 135.

attempt to analyze the problem in criminalistics, we have introduced the notion of *digital trace* [8].

There is a legal *tendency to subsume* specific activities – namely objective side, attack and goals, motive and specific conditions, under already existing merits of the case. However it is logical, it is not sufficient any more.

Police sciences and their applicable practice are forced to find new *ways of how to control* of specific activities showing evidence on their trots substance. They deal with this problem from the viewpoint of existing merits and from the viewpoint of methods of revealing, documentation and verification valid up today. Preventive and curative effect is almost completely minimized for this case, since there no power, time or finances are left. Despite that this effect is the most suitable from the economic viewpoint.

From the stated above it is clear that the meaning of a legal content of the notion “cyber crime” is much wider than in the past. In that time cyber crime was correctly and logically perceived only in relation to computer. Nothing else was comparable or existed.

How shall we classify today’s crime connected to credit or identification cards, which contain magnetic or other data media, altering of unprotected data during their wireless transmission etc.? Most technological devices, despite not being the means or goal of crime, contain a large number of various data. In the course of investigation of other crime, act or completely other activity not linked to this one, in the initial phase they have a classical character of a criminalistic trace and in the final phase, in ideal case, they obtain a character of forensic evidence.

All these traces are useful in verification of investigation versions of a case, in gathering evidence against perpetrator or on the other hand in confirmation of alibi of the innocent. In the trial traces become direct or indirect evidence. Data medium may contain records of computer user’s activity, mobile phone may contain a list of last calls of victim, video record of a department store or bank checkpoint may contain a view of customers in that particular time, car board computer may contain identification numbers (VIN), which offender might have forgotten to alter or he did not know how to do it while performing mechanical falsification of other vehicle numbers, telephone exchange may contain a list of all calls, GPS systems may contain objects grids (for instance car) in a concrete time etc.

All these questions are related to *information and communication technologies* and their possible misuse and control as well as revealing and investigating of this crime. Sometimes other type of

crime, not directly linked to these technologies, but impossible to be realized without these technologies is investigated.

Content of information and communication crime

European Agreement on cyber crime is a core document for analyses of a wider notion of crime related to information and communication technologies. Slovakia has not signed the Agreement yet and thus it is not legally binding. According to unofficial statements of relevant authorities, Slovakia has been waiting for re-codification. Other countries face the same problems along with its ratification and implementation into legal order [2]. Practically all-new EU countries except Slovakia and Czech Republic have ratified it²⁾ [8]. Unfortunately the proposal has not settled yet by its submitter and thus the legal framework remains as it has been realized under valid Criminal Code.³⁾

EU committees recommend using such classification of cyber crime, which would unite the legislation of European countries in order to ensure a unified criminal policy in prosecuting criminal acts within cyber crime.

On the basis of the stated analyses we have tried to work out a notion that would meet the needs of all four cooperating branches. We define *information and communication crime as an illegal and unauthorized act, in some cases connected to immoral behavior, which include misuse or unwarranted change of data obtained, elaborated, stored and distributed via information and communication technics and information and communication technologies.*

In the last 3 years in the Slovak Republic communication and information (ICT) crime has been committed in the following forms:

- Computer programs theft
- Theft of data stored in memory media of computer or server disc
- Different forms of non-cash payment misuse
- Unauthorized use of the means of communication and information technics, most often PC service theft
- Damage of data stored in memory media
- Computer viruses and their distribution
- Damaging or placing banned pages on servers⁴⁾
- Non-warranted advertising – ad spam.

Nevertheless, even in this case as well as when defining cyber crime, it is inevitable to divide content of this crime. On the one hand, from the viewpoint of the means and tools, on the other hand, from the viewpoint of offenders and the way of committing crime, it is divided into close ICT crime and crime committed by the use of communication and information technologies.⁵⁾ [8].

²⁾ Meteňko, J. et al: ISBN 80-8054-336-4, EAN 9788080543365, p. 24.

³⁾ the problem is related from the viewpoint of crime and its recourse with Criminal Code, but as well as from the viewpoint of its revealing and modernization and speeding up the work of the court predominantly by the use of electronic documents and digitalization of criminalistic and investigation documents, see [10] Meteňko, J.: New trends in criminalistic documentation, 2005, CD.

⁴⁾ whose content covers the merits of different crimes in compliance with Criminal Code.

⁵⁾ Meteňko, J. et al. ISBN 80-8054-336-4, EAN 9788080543365, p. 126 and next

Prevention possibilities in the field of communication and information crime

Generally speaking, crime prevention is a special area of prevention enforcement. Its aim is to prevent crime and the protection against crime. From the social and practical viewpoint, crime prevention represents scientifically reasonable, aimed, comprehensive, planned and coordinated impact on reasons and conditions of crime. The aim is to remove them or by a suitable selection of forms and methods of the impact to at least partly eliminate or to restrict their negative features and at the same time to support the creation of anti-criminogenic conditions. [6]

Repression of crime is a complementary notion to a notion of crime prevention. Its meaning covers the suppression of this phenomenon by the use of violent but legal means. Mutual relation of prevention and repression may be demonstrated by their functions in relation to legitimacy. Prevention measures shall create difficulties for possible crime and make offenders aware of the fact that crime is not worth. If despite this the law is broken, repression comes. Effective prevention decreases repression needs, and repression influences prevention backwards. Both parts take part in crime control.

Social prevention is a general prevention of all social and pathological phenomena. In might also be a specific crime prevention without which crime prevention would not be complete. Social prevention is a part of social policy. In our conditions, i.e. while examining the reasons and conditions of communication and information crime, social prevention means the widest context of prevention performance. In particular, it is important to create suitable social conditions in various areas of every-day life, building of social consciousness in the area of computer and communication technologies. Not less important task is performed by family, school and after-school activities, by cooperation of the police and organization and companies dealing with information technics and schools etc.

Unlike social prevention, situational prevention is specifically aimed at concrete type of crime. It follows the fact that particular types of crime occur in particular time, on particular places, under particular circumstances and are committed by particular offenders. Communication and information crime are typical for time discontinuance, i.e. this crime may be committed practically without interruption in extraordinary short time and also in any daytime. It is pretty hard to localize this crime since current mobile technics enables offenders to perform their illegal activity almost from any part of the Earth. On the other hand we must drop a few words about offenders. These are mostly highly qualified, erudite people, often-technical university graduates (electrotechnics, information science, cybernetics etc.). According to statistical data from abroad, mainly from USA, it is clear, that the age of offenders vary from 16 to 40. But most of them study at secondary schools and universities or are young employees of firms and businesses dealing with information or telecommunication technics.

Situational prevention makes use of several forms in this area.

The main forms are:

1. Classical protection
It covers mechanical preventive tools. They are used for hardware, peripheral equipment of computer systems and also for separate objects in which the equipment is placed. In particular we talk about so called hardware keys that prevent direct physical access to equipment such as hard disc, sluts, buses, and internal and external communication. Other tools of classical protection are lock systems of premises, door security systems, bars, security covers of mobile data media etc.
2. Technical protection
Besides classical technical protection such as electronic safe signalizations, closed-up TV circuit etc. there is also so called software protection, which is important in the area of communication and information crime. By it we understand software equipment of the systems and peripheral devices in order to provide signalization and to prevent unauthorized access into system with a particular procedure (e.g. while an unauthorized person tries to access data file, the content of the file is automatically erased so the offender does not have any chance to have a look into a file).
3. Physical protection
It is provided mainly by security guards, private security services, but in some case also by the police or army.
4. Regime protection
It covers predominantly administration and organizational measures, which shall provide good running of the whole safe system. Within this area it is inevitable to make use of safety regime. It means to determine regime access for authorized persons to data and information and communication system, to ensure key and password regime, multilevel cipher protection measures, authorized access and exit from the system or premises where the system is placed etc. [7]

In connection to crime prevention, the notion of victim prevention has occurred. Such prevention is specifically oriented with the aim to prevent man from being a victim. In today's fast development of information and communication technics, man as an owner and user of this achievement of 20th and 21st century becomes a potential victim of communication and information crime practically from the time he encounters it for the first time. Obviously it is quite an open understanding of this problem.

The most endangered are the firms and organizations, which make use of this technics for storage and elaboration of huge amount of data of strategic character. And these are later the subjects of interest of offenders involved in this type of crime. We cannot forget about spreading electronic business and Internet banking. Bank and financial institutions are directly endangered, but within a wider context, consequences of possible crime (illegal bank transfers, data thefts from bank clients) affect clients of these organizations as well.

Victim prevention may be performed on a general level, in relation to all people, their education, informing them about crime danger, their training in preventive behavior, advertising technical possibilities of protection against crime, conferences and lectures given by experts in a field etc.

The second aspect of crime prevention complexity is the fact that social, situational as well as victim prevention might be realized as primary, secondary and tertiary prevention from the viewpoint of crime development.

Primary prevention has an impact on wide public, which might not be affected with this crime. It approaches mass or groups of people and presents responsible methods of education.

Secondary prevention deals with risk groups or individuals that are probable to become offenders or victims. Moreover it deals with elimination of criminogenic factors. Methods of information distribution are in fact likewise, circle of people is closed-up. Substantial change is linked to elimination of criminogenic factors – as mentioned above, what requires besides already known methods and distribution ways, to use predominantly new – technologies and methods and applications responding to a social situation.

Tertiary prevention concentrates on groups or individuals that have already been involved in crime or have become its victims. In fact it is relapse prevention. It is very interesting that people once involved in committing this type of crime are becoming the best experts for protection of information and communication systems [11].

Conclusion

Every society is accompanied with a certain level and scope of crime as a feature of non-conform interests of individuals or groups. In our opinion, modern technologies do not bring any changes into this situation. However, it seems that information and communication technologies cause the negative development of crime; this fact is influenced more or less by a quality and scope of communication and exchange of information. The bigger problem is that relevant social structures of the society are not well prepared to make use of digital communication and information technics and technology in their jobs, and particularly to use them in the course of control of homogeneous and heterogeneous types of crime.

References

- [1] CULBA, M., FELCAN, M., GÝMERSKÁ, J.: *Definition of terrorism and significance of knowing its notion spectrum*, In. Threats of present-day international terrorism and possibilities to fight against it. Bratislava: Academy of PF. ISBN 80-8054-325-9. p. 135.
- [2] DLOUHÝ, M.: *Convention on cyber crime*. In. Reports from criminalistics, 2/20004, volume XLVIII. p. 37–38.
- [3] GELETA, M.: *Tasks of criminal police in prevention and revealing some types of cyber crime: Conclusion* / Jozef Meteňko. – Bratislava: Academy of PF, 2001. (78p) p. 55–59.
- [4] CHALKA, R., HOLCR, K., HOLOMEK, J.: *Criminal scene of the Slovak Republic: Prognosis up to the year 2000 with the view up to the year 2010*. – Bratislava: Academy of PF, 1998. 84p.
- [5] JAŠEK, R.: *Defense against socio-technical manipulation*, In. Threats of present-day international terrorism and possibilities to fight against it. Bratislava: Academy of PF. ISBN 80-8054-325-9. p. 104–108.
- [6] KLOKNEROVÁ, M.: *Some possibilities of how to apply education in the work of criminal police in the course of crime prevention*. In. Police theory and practice 4/2003. p. 79–88.
- [7] LÁTAL, I.: *Cyber crime as a crisis phenomenon and its prevention via administration proceeding*. Reports of expert studies from the seminar Criminalistic problems in revealing, investigation and prevention of software piracy. PA CR, Prague, 1999, p. 336
- [8] METEŇKO, J. et al: *Criminalistic methods and possibilities of sophisticated crime control*. Bratislava 2004. Academy of PF of SR in Bratislava. ISBN 80-8054-336-4, EAN 9788080543365. p. 356
- [9] METEŇKO, J.: *International seminar on cyber crime*. In. Police theory and practice. Volume 6, no. 4 (1998), p. 122–123.
- [10] METEŇKO, J.: *New trends in criminalistic documentation*, In.: Reports from the seminar organized by FSI PF on 9th – 10th March 2005, “Criminalistics in practice”. Bratislava 2005. FSI PF Bratislava, CD.
- [11] METEŇKO, J.: *Penetration into information systems and criminalistic knowledge*. In.: Reports from international conference Internet and competitive strength of the business. UTB Zlín, 2005.
- [12] MURDZA, K.: *Sociological analysis of terrorism*, In. Threats of present-day international terrorism and possibilities to fight against it. Bratislava: Academy of PF. ISBN 80-8054-325-9. p. 110–111,
- [13] RAK, R.: *Information science in criminalistic and security practice*. Prague, Police Presidium CR, 2000. (471)
- [14] RAK, R.: *Cybernetic crime and cybernetically related crime*, In. Reports from scientific conference “Advances in criminalistics”, Police Academy, Prague, 2004.

Ján Mikolaj *

CRISIS MANAGEMENT IN SECURITY ENVIRONMENT

Public security is, in present-days, the key element of society in national and in international space. The jeopardy of the society obtained unprecedented measure especially after terrorists' threat and attacks. The defence of the society over these threats is ethical and overall human problem. A human being is jeopardized by the ideological or by quasi-humane thoughts and enforced by their power, but also the nature hard acts against him. The interest of governments is to secure the society against the nature disfavour and to secure it also against jeopardised anti-human powers. Risk in human-doing, crisis in technical, technological, economic and social matters are sources of inequality in society. This article is an essay of security research and its aim is to point out to discrepancies in human doing and human being mainly from the viewpoint of crises influence of human and society security.

1. Basis of security research

Successful solution of security tasks is not only the question of solving security threats in praxis but it is also a problem of security substance investigation and of respectable tools used for their resolutions. Systematic solution of security matters desires the concentration on theoretical problems related to security, its substance and on specific problems connected with risk, crisis or emergency solutions. The role of the security knowledge is based on detection of security substance, new aspects on security matters, reasons of their origin and methods of their disclosure.

If we intend to perceive the matters of security as a scientific event, we have to clarify the substance of this event and demonstrate that scientific tools for uncover the existence of its substance. Further, to review if this security event exists objectively in specific environment, and if this specific environment influences this security event with its own behaviour and consequences. Objectively it can be said that crystalline environment does not exist and that every space is covered by risk and uncertainty. Risk is the source of danger, fear and distress and crisis is the picture of unbalance.

To discover this unbalance requires finding out the reason why it appears, under what causality, what is its value and significance. According to our opinion, the unbalanced situation is the result of undermined risk and represents the basic point of crisis. To consider the basis of crisis of any entity means to clarify the development life of considered issue and to find out the reasons why a smooth evolution is endangered. Reasons are, apparently, outside as well as inside of the considered matter. The outside reasons in technical and technological elements are characterised as menace (threats), the inside reason lies in loss of reliability. The outside environment is full of risks, the inside of depreciation. Therefore, there are ex facie several ways how to review the unbalanced problem from the view of environment and at the same time from the view of living conditions of the considered feature (element, assets, phenomenon).

Crisis is very difficult but transient phenomenon, peak period to overcome the highest difficulties, peak of tension, determining moment after which the change in the development of the operation (organisation, system) begins. It is a complex of fast developing actions that enlarge the scope of destabilising powers over the acceptable level and enlarging violence in the institution (system). Crisis is a situation where jeopardy of assets, interests or aims of interested entities turns up. Crisis is a moment of risk, danger, fear or uncertainty in value production, industry, business, banking and financing, in the all economy, politics and society.

The American Heritage Dictionary defines the crisis as: 1. a) Crucial or decisive point or situation; a turning point; b) An unstable condition, as in political, social, or economic affairs, involving an impending abrupt or decisive change. 2. A sudden change in the course of a disease or fever, toward either improvement or deterioration. 3. Emotionally stressful events or traumatic change in a person's life.

According to WordNet the noun crisis has two meanings: 1. unstable situation of extreme danger or difficulty; 2. crucial stage or turning point in the course of something.

According to the US Department of Defence Dictionary the meaning of crisis is expressed in this way: "An incident or situation involving a threat to the United States, its territories, citizens, military forces, possessions, or vital interests that develops rapidly and creates a condition of such diplomatic, economic, political, or military importance that commitment of US military forces and resources is contemplated in order to achieve national objectives."

Even any other definitions can be used to characterise the substance of crisis, but there is no need to concentrate further on this subject since we are not dealing basically with crisis as a subject matter. The most important role is in application of these definitions or meanings to the special fields of consideration. To deal with crisis is to role of crisis management.

* Ján Mikolaj

Faculty of Special Engineering, University of Žilina, 1. mája 32, SK-010 26 Žilina, Slovakia, E-mail: Jan.Mikolaj@fsi.utc.sk

2. Crisis management

Crisis Management can be generally considered in two ways:

- 1) as a common problem related to all project subjects under consideration that deals with formal models and tools of different technologies (e.g. industry, business and operation, transport, finance, etc.), or
- 2) to go directly to the middle of the solution of the specific problem and from, the feasible crisis management solution tools, choose the right one that can solve the incident crisis situation.

In the first way there is a need to know not only the overall basic problems of the performance of the investigated subjects and their environment (technical, technological, economic, social, etc.), but, on the one hand, also crises elements with which these subjects can be confronted, and, on the other hand, the methods and tools of crises management solutions that can be chosen for feasible solution.

In the second way, simply saying, a specific problem has a specific solution. A partial problem of investigated subject has only specific solution for solving this specific partial problem. In practice it means that specific, say emergency situation, can be solved only by relevant and respected tool that is placed at a disposal. In this sense, the specific partial problem can be solved only by specific measures (e.g. in a traffic accident heavy injured people can be transported only by ambulance), but the problem itself cannot be solved with this tool in complexity (road, railways, airplane traffic accidents, or terrorist attacks on people, objects or on infrastructure, etc.).

There exist even other ways that are going directly to the substance of crisis problem solution. As it was already mentioned, crisis is the specific form of considered matter development and always has the reason for its birth. So to consider the origin of the matter evolution can be the source of crisis genesis. To use a crisis like a method of influence the development is also the aim of so called *crisis management*. Knowing tools of crisis management that can be used in specific forms in specific environment and to apply them in a right way to decrease tension coming from stress situation is also the crisis solution road but used with relevant tools coming from different space. This enables us to consider the crises management as an overall instrument of crisis solution.

Taking to account that risk is a source of crisis, the problem of risk could be wide spread to the crisis management tasks. The advantage of this solution lies on such merit that the crises management can solve a crisis situation in more broadness and in relation to its substance. Therefore, the bases of crisis management could be considered as an application tool for development of relevant circuits of items. For specific items solutions problems specific tools can be directly chosen in relation to their specific characteristics, attributes and objectives. This is usually how research and in firms, managing institutions, deal with solving their complicated technological and economic task. This can be an attitude to risk

and crisis solutions through the application of crisis management in entrepreneurship.

Before considering different sights to crisis management and their use in solving security situations, let us have a look at some definitions that can be found in some of sources or my own interpretation. For being short, we can find this expression of crisis management (quoted only partially):

Crisis management involves identifying crisis, planning a response to the crisis, confrontation and resolving the crisis. Crisis management can be applied in almost any field of endeavour, but it is most commonly used in international crises relations, political sciences, economics and specific managerial cases (environment, infrastructure, etc.). In general terms, the theory of crisis management can be divided into crisis three fields, in bargaining and negotiation, in crisis decision-making and in crisis dynamics.

In business the crises events may be divided in these fields:
 -) Financial crisis – in short term liquidity or cash flow problems; in long term bankruptcy problems;
 -) Public relations crisis – negative publicity that could adversely effect the success of the company;
 -) Strategic crisis – changes in the business environment that call the viability of the company into question, etc.

US Department of Defence Dictionary of Military and Associated Words, 2003 defines the crisis management as “Measure to solve a hostile situation and investigate and prepare a criminal case for prosecution under federal law. Crisis management will include a response to an incident involving a weapon of mass destruction, special improvised explosive device, or a hostage crisis that is beyond the capacity of the lead federal agency.” As crisis management is very often identified with military agenda, this quoted military definition can be probably useful for the researcher even if this task is not within the framework goals that are being under civil security solutions.

Crisis management on political level is considered as a tool for governmental policy in securing the inner security against the outboard danger, or as a tool for defence of state interests in political and social manners. Crisis management can be also considered as a basic strategic concept in the state (governmental) security policy that contributes to the efficient defence against national and international significant crises situations and conflicts.

Crisis management can be considered as a matter of security either as technological security defined as reliability, or as firm (entrepreneur) security defined as capital, financial, labour, legal et al. In the entrepreneurial (business, enterprise) activities crisis management is known as a method of guidance (control, operation, supervision) and than as a rectification (regulation) or entrepreneurship activities in such way that if any crisis arises and if crisis occurs, the restructure of the firm will be possible but always on higher level of operation what presents an acceleration element. If this will not succeed the entrepreneur activities may vanish.

Crisis management can be considered as public and social problem embodied in ethnical, ideological, migration, unemployment, education, poverty and other similar problems. In case that these problems are not continually solved they can flow in conflicts on national or even international level.

Generally, *crisis management* can be then defined as a specific activity of leading personnel concentrated on solving extraordinary and/or critical situation by using specific principles, methods and performance with the aim to overcome its negative consequence (effect). As a result the reason lies on functional recovery of considered entity.

Crisis management is a complex of operation (guidance) activities of supervision (steering) bodies with concentration on risk and nuisance analyses, on applying progressive anti crises remedies, on organisation, realisation and control of activities conducted by building-up actions against occurrence of possible crises situations (i.e. stage of prevention) and of activities on their solutions.

Crisis management as institutional entity (note: does exist in some countries on national, regional and/or local levels) means an organisation of leading and analytical bodies with concentration on analysis of crises events genesis, their possible reasons, consequences and results, choosing methods and remedies on their preventions and on elimination of their outcomes.

Crisis management as theoretical discipline is a logically and methodologically ordered scheme of potential crises, their reasons and consequences, of principles, methods and measures of their solutions.

2. Security definitions

If we intend to qualify the security environment, let us have look first at the security expressions.

The term *security* comes from Latin *securitas*, *f.* that means insouciance, safety, certainty, safeguard, even peace of mind [1].

The Compact Oxford Dictionary characterises the *security* term as: 1. State of being or feeling secure; 2. Safety of a state or organization against criminal activity such as terrorism or espionage; 3. Thing deposited or pledged as a guarantee of the fulfilment of an undertaking or the repayment of a loan, to be forfeited in case of default; 4. Certificate attesting credit, the ownership of stocks or bonds, etc.

The American Heritage Dictionary of the English Language, Fourth Edition, 2000 the password *security* specifies as: 1. Freedom from risk or danger; safety. 2. Freedom from doubt, anxiety, or fear; confidence. 3. Anything that gives or assures safety, as a) a group or department of private guards, b) measures adopted by a government to prevent espionage, sabotage, or attack, c) measure adopted, as by a business or homeowner, to prevent a crime such as burglary or assault, d) measures adopted to prevent escape, ...

4. Something deposited or given as assurance of fulfilment of an obligation; a pledge. 5. One who undertakes to fulfil the obligation of another; surety. 6. *Plural*. Written evidence of ownership or creditorship; especially a stock certificate. 7. Measures adopted to guarantee freedom or secrecy of action, communication, of the like, as in wartime.

The Encyclopaedia of Security Management defines the security only in an indirect way. In the password of security system it says that establishing important assets can be attractive aim for several threats. The threats can arise from casual or highly sophisticated actions from very good armed and trained professional criminals, drug users or terrorists. The background of threats is a key to form security systems. From this point of view it can be deduced that the nucleus of security can be understood as personal assault, public nuisance and property and assets.

This understanding can be found by characterising the role of security manager when he expressed that the best defence against dynamic threats and possible catastrophic damages is fully integrated security programme which composes architectonic, technological and operational elements into flexible and sensitive security system.

In the WordNet Lexicon we can find these nine meanings of security: 1. the state of being free from danger or injury; 2. a formal declaration that documents a fact of relevance to finance and investment; the holder has a right to receive interest or dividends - synonym: certificate; 3. a department responsible for the security of the institutions property and workers; 4. measures taken as a precaution against theft or espionage or sabotage etc.; 5. defence against financial failure - synonym: protection; 6. freedom from anxiety or fear; 7. an electrical device that sets off an alarm when someone tries to break in - synonym: security system; 8. property that your creditor can claim in case you default on your obligation - synonym: surety; 9. a guarantee an obligation will be met - synonym: surety.

Very important is the NATO view on the security issue. In the NATO Handbook, [7] we can read this recognition of security: "To provide one of the indispensable foundations for a stable Euro-Atlantic security environment based on the growth of democratic institutions and commitment to the peaceful resolution of disputes, in which no country would be able to intimidate or coerce any other through the threat or use of force" (page 31-32).

The European Union understands the security, from the viewpoint of common foreign and security policies, as an assurance of security of the Union and its citizens and therefore the minimising of different sources of threads. The security policy determines the scope and means of activities that minimises risks. The background of this policy is incorporated in the security doctrine. The security system incorporates the economy, politics, culture of society and personality, science and technology, geopolitical and geostrategic situation and public activity.

Bearing in mind all the expression of security one can see that the meaning is very different and indicates the attitude of its observer to security. Anyhow, for the scientific point of view, it is required to express the substance of the security matter as a starting point of scientific methodology that deals with security issues.

3. Security environment

For the illustration of security meaning in entrepreneur's environment we can use the characteristic that can be found in the Encyclopaedia of Security Management [3]. The security of a firm lies on: 1. improvement of quality and prices, 2. to built up tight relations with consumers, 3. to create close relations with suppliers, 4. to guarantee effective use of technology, 5. to employ minimal size of levels in managerial hierarchy, 5. systematically improve the qualification of security staff.

Let us try to identify in what environment we can locate the security events. In our contribution to the Conference of Security, Košice 2004, we expected to allocate the security problems primarily in these areas: - security of territory; - defence before unexpected danger and attacks; - armed and militant conflicts; - security (safety) of people and property; - civil security, - security of society; - jeopardy by violence; - jeopardy by mass attacks on inhabitants and on buildings and structures: terrorisms; - frauds, - malversation, defraudation, intimidation; - security (safety) before pseudo philosophic forces; - psychical, moral, ethical, belief, opinion; - security guaranteed by law; - financial, economic, industrial, energetic, infrastructure, commercial, consumer protection security; - technical and technological security, - security of special equipment; - hardware and software security, etc.

Science and technology is also the key to Europe's future. Scientific research, technological development and innovation are at the heart of the knowledge-based economy, a key factor in growth, the competitiveness of companies and employment.

The European Union has recently placed research to the service of security. The reasons are mainly in the security situation not only in European but also mainly in the world-wide security situation. Therefore the European Union puts great emphasis on security research alongside informatics and technology. The European Union therefore considers security as a major challenge in Europe: the security of individuals, the State, transport and telecommunications networks in the face of organised crime and international terrorism, in particular bio terrorism. Increasing security involves advancing knowledge of detection, intelligence, reconnaissance and surveillance, as well as analysis of causes of conflicts.

At the beginning of 2004 a preparatory action on this issue was launched. Taking this a stage further, and on the basis of the report of a high-level European group, a clearly identified "European Security Research Programme" is due to be implemented. With more substantial resources allocated to it, the aims will be to: - increase public security in Europe in the fields of civil protection, for example, and combating bio terrorism; - help the Union to fulfil its tasks of preserving peace, preventing conflicts and strengthening international security, in keeping with the principles of the United Nations Charter. We highlight this above all because the Faculty of Special Engineering of the University of Žilina, and I personally, are working on project proposal within the EU research programs.

Similar situations are with NATO security research [8]. The priority research topics on countering threats to security are in less obviously dangerous fields, but are in areas that nevertheless pose a risk to security and stability, particularly in a regional context, and scientific and technical studies. These priority topics concentrate on: - environmental security (e.g., desertification, land erosion, pollution, etc.), - water resources management, - management of non-renewable resources, - modelling sustainable consumption (e.g., food, energy, materials, fiscal measures and environmental costing), - disaster forecast and prevention, - food security, - information security, - human and societal dynamics (e.g. new challenges for global security, economic impact of terrorist actions, risk assessment, management of science, science policy, security), - related political science, and international relations in general.

As we can see, the security environment is in the focus on human interest. Human life is a central point of human being and it cannot exist if it is jeopardised by nature or by other people due to the lack of human honesty.

Summary

Security has many faces. In this article we have tried to describe the basis of security events. Due to the last incidents in the world, the security task gains an extraordinary attention. Higher attention is paid to the security research in the programs of international institutions including NATO and European Union. The subjects of research are not only classical security issues but under considerations are new security cases with high influence on society and new technologies, and actions connected with solving extraordinary and emergency situations with which are we endowed by the nature.

References

- [1] ŠPAŇAR, J., HRABOVSKÝ, J.: *Latin - Slovak, Slovak - Latin vocabulary*, Slovenské pedagogické nakladateľstvo, Bratislava, 1987
- [2] *The American Heritage Dictionary of the English Language*, Fourth Edition, 2000
- [3] FAY, J. J.: *Encyclopaedia of Security Management*, Butterworth-Heinemann, USA, 1993
- [4] MIKOLAJ, J.: *Security Task (in Slovak)*, International terminology workshop, Security, Security Risk and Threats in Security Management, University of Žilina, Faculty of Special Engineering, 9. september 2003, proceedings, pp. 56-63

- [5] PAWERA, R.: *New View on Security in European Union (in Slovak)*, Policajná teória a prax, Akadémia policajného zboru, Bratislava, 3/2004
- [6] *Science and technology, the key to Europe's future - Guidelines for future European Union policy to support research*, Commission of the European Communities, Brussels, 16. 6. 2004, COM (2004) 353 final
- [7] NATO Office of Information and Press, Brussels, 2001
- [8] NATO - Security Through Science.htm
- [9] www.uniba.sk/filit
- [10] <http://www.answers.com/crisis%20management>.

Martin Zachar *

COMPARISON OF SOME PHYSICAL PROPERTIES OF FOAM CONCENTRATES – PYRONIL AND ALFA A

The choice of a suitable foam concentrate is the first precondition of achieving a foam (as an extinguishing agent) with optimal properties to extinguish A and B class fires. On the basis of the given facts, this article compares some physical properties of foam concentrates and their effect on the environment (environmental friendliness).

Keywords: foam concentrate, physical characteristics, Alfa A, Pyronil, effect on grass stands

INTRODUCTION

The existence of mankind has been accompanied with fire accidents since its birth. In the ancient times the natural fire accidents were the only fire source necessary for our ancestors to survive in unpleasant natural conditions. Fire was not always just a servant but caused damages and for many cultures and civilisations it was the reason of their fall.

We are trying to find an effective extinguishing agent for rapid extinguishing with the least harmful effect on the environment.

Extinguishing agents are inorganic and organic substances or their mixtures in solid, liquid or gas state. This is a summary of basic properties required for every extinguishing agent:

- high extinguishing effect (fast interruption of combustion on a large area with little consumption of an extinguishing agent)
- no harmful effects on objects and materials being extinguished (environmental friendly)
- no harmful effects on human and live organisms while using and storing
- availability, low prices, storing stability

There are many extinguishing agents. Their properties are determined by physical and chemical reactions occurring while interrupting combustion [1].

The objective of this article is to characterise and compare physical and chemical properties of Alfa A and Pyronil foam concentrates (tensides) used for foam production and their consequent effect on grass stands.

Foam concentrates characterisation

Concerning the chemical structure, a foam concentrate is a surface-active substance (tenside) which has to perform following functions:

- very good water solubility
- adhesive to wetted substance

A molecule of tenside consists of two parts:

- hydrophilic, water-soluble part which guarantees good water-solubility and creating of true and colloid solutions
- hydrophobic part which is absorbed on the surface of wetted substance and guarantees tenside adhesiveness to wet surface [3].

According to the character of hydrophilic molecule part, tensides are divided into:

- anionic, the hydrophilic molecule part is anion,
- cationic, the hydrophilic molecule part is cation,
- nonionic, the molecule of surface-active substance does not create ions.

Classification of foam-making additives according to STN EN 1568

According to the composition the foam making additives they are divided into the following groups:

- *protein foam concentrates* (P): liquids created from hydrolysed proteins,
- *fluoroproteine foam concentrates* (FP): protein concentrates with fluorinated surface active additives,
- *synthetic foam concentrates* (S): concentrates consisting of mixtures of surface active hydrocarbons can have fluorinated surface active agents with added stabilisers,
- *alcohol resistant foam concentrates* (AR): are suitable for extinguishing hydrocarbon fuel beside they are resistant to disintegration if used on the surface of burning, water soluble fuel, some of them can form polymeric layers on alcohol surface,
- *aqueous film-forming foam concentrates* (AFFF): generally consist of mixture of hydrocarbon and fluoroproteine surface-active agents and can form water film on the surface of some hydrocarbon fuel,

* Martin Zachar

Department of Fire Protection, Faculty of Wood Science, Technical University of Zvolen, Masarykova 24, 960 53 Zvolen,
E-mail: martinz@orangemail.sk

- *film-forming fluoroproteine foam concentrates* (FFFP): fluoroproteine concentrates which can form water film on the surface of some hydrocarbon fuel [5].

EXPERIMENTAL PART

The objective of the experimental part was the comparison and characterisation of measurements and experiments. These experimental methods were carried out to verify some foam concentrates properties.

Testing the foam concentrates

The main reason of testing the foam is to identify the foam efficiency. Concerning the given fact that the foam is not a clearly chemically defined agent, as its basis can be of various foam concentrates and can be made by different methods of foam expansion. So it is possible to achieve a different quality of foam for the use of the same concentrate. [3].

The aim of the experiments is to verify the basic technical properties of foam concentrates:

- density determination
- water-solubility determination
- determination of pH-metry
- viscosity determination
- electric conductivity determination
- dry matter determination
- effect on grass stands

The density determination of chosen foam concentrates was realised by a densimeter. The ambition was to work with liquids whose density is close to water density.

The water solubility determination is based on the preparation of various concentrations of foam solutions. We worked with 0.4 % and 4 % foam solution concentrations and 100 % concentrates.

The pH number determination of foam solutions was determined by a pH-meter.

The viscosity determination was carried out by an Engler viscosimeter. The viscosity of chosen foam concentrates was measured at 20 °C temperature.

The electric conductivity determination was determined by a conductometer with glass electrode.

The dry matter determination was measured for 100 % concentrate only.

The effect on the grass stands was determined by application of 0.4 % and 4 % foam solution concentrations and 100 % concentrate and the following visual judgement [4].

RESULTS AND DISCUSSION

Description of the foam concentrates agents and their application.

Table: 1.

Foam concentrat	Characterisation	Application
Alfa A	<i>Foam concentrate (tenside)</i> yellow to brownish colour liquid, good water solubility, distinctive smell	forms water film, very good at wetting the surface in 0.4 to 6 % foam solution concentration
Pyronil	<i>Synthetic foam concentrate</i> dark brown colour liquid, good water solubility, distinctive smell	production of medium and light foam from 6 % foam solution concentration

Density of foam concentrate is the fraction of weight and volume. The results of the arithmetic mean achieved from the density values at 20°C are mentioned in table 2.

The water solubility is very important because of its influence on the density values of foam concentrates, the results are mentioned in table 2.

Based on the pH determination it is possible to state the conclusions about corrosive behaviour and bacterial disintegration of water foam concentrate, the values mentioned in table 2.

The viscosity determination provides us with results of behaviour during blending and suction process. The more viscous the solution is the worse the suction ability and hosepipe flow is. The viscosity depends on temperature (increases with lowering temperature)[2].

The determination of electric conductivity obviously shows dependence of conductivity values on concentration of foam solution.

The determination of percentile share of dry matter in foam concentrate shows amount of substance after water evaporation and a possibility of its deposition in the soil [4].

By preparing various concentrations of foam solutions it was found out that all tested substances were soluble into whole water volume.

The density of solutions is relatively the same, comparable to water density which is around 1000 kg.m⁻³. Foam concentrates had slightly higher density up to 1010 kg.m⁻³ for Alfa A and Pyronil as well, the manufacturer declares density ranging from

The determination of chosen physical properties of foam concentrates Alfa A and Pyronil

Table 2.

Name of the sample	Solution concentration [%]	Solution density [g.cm ⁻³]	Solution pH	Solution conductivity [mS]	Foam concentrate viscosity at 20 °C [mPa.s]	Foam concentrate dry matter [%]
Distilled water	100	1000	7	10		
Alfa A	0.4	1003	7.13	124		
	4	1003	5.9	140		
	100	1010	4.44	580	1 780	3
Pyronil	0.4	1004	6.37	132		
	4	1005	6.37	192		
	100	1010	5.68	7 300	1 785	15

990 to 1010 kg.m⁻³ for Alfa A, density values of Pyronil are not provided.

Concerning the pH number of foam solutions it was established that the values vary from 7.13 to 4.44 (Fig. 1). 100 % foam concentrates of Alfa A and Pyronil are significantly acid. Distilled water has the most suitable pH number 7, it's neutral. Foam solution of Alfa A with 0.4 % concentration is very close to this value. Water solutions of Pyronil have lower pH values, they are acid, which is in this case a disadvantage.

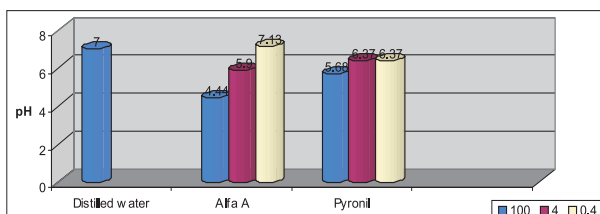

Fig. 1: pH dependence on concentration of foam solutions

The viscosity determination helps us to get results of reactions occurring during blending and suction process. The more viscous the solution is, the worse sucking ability and hose pipe flow rate is. Viscosity depends on temperature (increases with lowering temperature). It was possible to measure only the viscosity of 100 % foam concentrates in our laboratory conditions. The viscosity of Alfa A foam concentrate is 1780 [mPa.s] and 1785 [mPa.s] for Pyronil, which are almost the same.

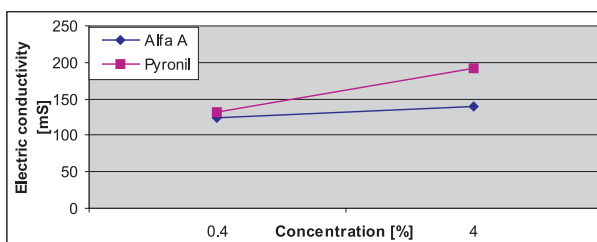

Fig. 2: Dependence of electric conductivity on foam solution concentration

Electric conductivity is an undesirable property of extinguishing foam solutions. The measurement results of both foam concentrates (Fig. 2) show that the conductivity increases with increasing concentration. The electric conductivity of 100 % concentrate is very high.

Determination of dry matter percentile share shows that dry matter percentile share of Alfa A is 5 times lower than Pyronil.

The effect on the grass stands is very important because of using foam concentrates in the exterior and their consequent effect on the environment.

We sprinkled 0.18 l of foam solution on the area of one box (0.09 m²), this volume was calculated on the area. We followed The Collection of Directives of the Presidium of Fire and Rescue Corps [6], which suggests the usage of 2 l volume per 1m². We noticed changes on the grass stands 10 days after the application of foam solutions.



Fig. 3: The grass stands before foam concentrate applications

CONCLUSION

According to the carried-out experiments it was found out:

- Density of foam concentrates are relatively similar and comparable to water density,

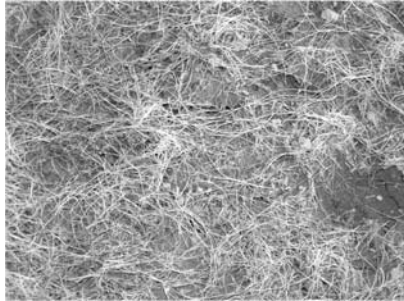

Fig. 4 : Samples after application of 100 % Alfa A concentrate. There were large visible changes, the grass was destroyed and died out in short time.

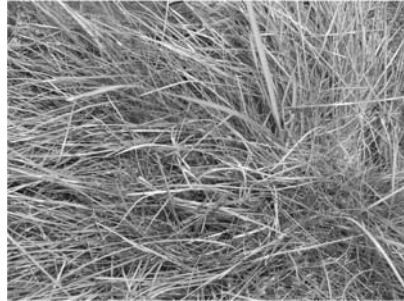

Fig. 5 : Samples after application of 4 % Alfa A concentrate. There were slight visible changes, the ends of grass stalks changed in shape and colour, became yellow and dried up.

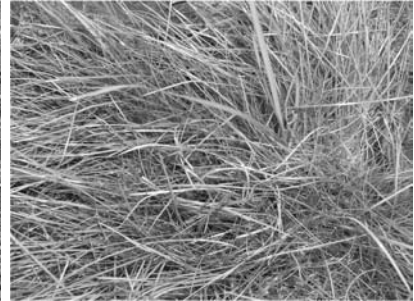

Fig. 6 : Samples after application of 0.4 % Alfa A concentrate. There were no changes visible.



Fig. 7 : Samples after application of 100 % Pyronil concentrate. There were large visible changes, the grass was destroyed and died out in short time.

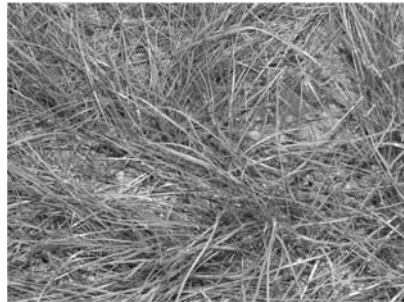

Fig. 8 : Samples after application of 4 % Pyronil concentrate. There were slight visible changes, the ends of grass stalks changed in shape and colour.

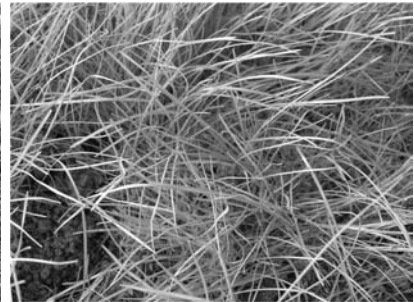

Fig. 9 : Samples after application of 0.4 % Pyronil concentrate. There were no changes visible.

- Water solubility is the same, foam concentrates were well soluble into whole water volume,
- pH number values decrease with increasing concentration, 100 % concentrates are very acid,
- Viscosity values are the same and comparable,
- Electric conductivity increases with increasing concentration and values are extremely high for 100 % Pyronil concentrate,
- Dry matter percentile share values are different and Pyronil values are 5 times higher than Alfa A values,
- There are negative effects on the environment of 100 % concentrates of both agents.

Summary

Fire accidents cause enormous damages even losses of human lives every year. It is necessary to develop and test new technologies, technical equipment and extinguishing agents for fire fighting.

The aim of this article was to test and compare the selected physical properties of foam solutions regarding to their effects on grass stands.

We assumed that the foam concentrates Alfa A and Pyronil would have similar parameters, suitable properties to produce foam and they would have a negative effect on the environment at higher foam concentrations.

References

- [1] MARKOVÁ, I., SLOSIARIK, J.: *New sorts of extinguishing materials in relation to environment (in Slovak)*, Mobilné energetické prostriedky - Hydraulika - Ekologické oleje - Životné prostredie, TU Zvolen, FEVT Zvolen 1999, pp. 115-120.
- [2] MARKOVÁ, I.: *Correlation of physical properties of chosen foam concentrates (in Slovak)*, IV. Int. conference FIRECO 2001, Trenčín 2001, p. 175-178.
- [3] ORLÍKOVÁ, K.: *Extinguishing materials (in Czech)*, EDICE SPBI SPEKTRUM 1., Ostrava 1995.
- [4] ZACHAR, M.: *Testing of selected physical-chemical properties of aquatic solutions foam concentrates in relation to their influence to grass vegetation (in Slovak)*, Diploma thesis, Zvolen 2004, p. 114.
- [5] STN EN 1568 *Technical conditions for foam concentrations for heavy foams for surface use for liquids able to be combined with water (in Slovak)*, Hasiace látky - Penidlá 4, pr. A.
- [6] *Collection of Directives of the Presidium of Fire and Rescue Corps (in Slovak)*, Zbierka pokynov prezidia HaZZ, 39/2003.

HARMONISED APPROACH TO THE ASSESSMENT OF MAJOR ACCIDENT RISKS IN THE FRAMEWORK OF SEVESO II DIRECTIVE: CASE STUDY ON ARAMIS METHODOLOGY APPLICATION

The goal of the contribution is ARAMIS methodology presentation by a specific case study on the assessment of risks of major accidents in an industrial establishment unclassified within the scope of the SEVESO II Directive, but in spite of this the enterprise that represents a significant risk of major accident to employees and neighbouring inhabitants. At present, any legislative pressure is not being produced on the operators of such unclassified sources to make risk analyses and contribute thus to major accident prevention and risk reduction. The ARAMIS methodology was developed as a project within the 5th EC Framework Programme in a team of known European workplaces with the aim to prepare a harmonised methodology for risk assessment especially for the purpose of meeting the conditions of the SEVESO II Directive. A subgoal of the submitted analysis was to test the applicability of the new ARAMIS methodology to the conditions of unclassified risk sources.

Key words: ARAMIS, risk assessment, SEVESO II, major accident prevention

1. Introduction

The ARAMIS methodology (“Accidental Risk Assessment Methodology for Industries in the framework of the SEVESO II directive”) was developed as a project within the 5th EC Framework Programme (Energy, Environment and Sustainable Development Programme) in the period from 2002 to 2004. Members of the team were prestigious European institutes, such as INERIS, EPSC, JRC, TU Delft, etc. The ARAMIS project proposes a harmonised methodology for risk assessment aimed at diminishing uncertainties and result variability and at including the evaluation of risk management efficiency into the analysis. ARAMIS should be understood as a comprehensive tool for efficient risk identi-

fication and analysis with many steps prepared in advance and recommended. The common procedure of ARAMIS methodology is summarised in Figure 1.

The whole procedure may be divided into three basic steps, the outputs of which are relevant indexes as follows:

1. the assessment of consequence severity (S – severity index),
2. the assessment of the efficiency of risk management (M – management index),
3. the assessment of vulnerability of the surrounding environment (V – vulnerability index).

All the indexes may be assessed separately, but primarily the indexes S and M are considerably interconnected in the selection of reference accident scenarios and the calculation of consequence severity, when effective measures to reduce risks may affect the frequency of accidents and/or to limit the extent of accident consequences.

The detailed description of the ARAMIS methodology is presented in a form of a case study in the enterprise unclassified within the scope of the SEVESO II Directive (or the Czech Act No. 353/1999 of the Code on major accident prevention, as subsequently amended). In spite of this, in this industrial establishment producing drinks, several significant hazardous substances are present. By agreement with the enterprise management, any name of the enterprise is not presented; however, all given data correspond to practical conditions in the enterprise not subject to the legal force of the Act No. 353/1999 of the Code.

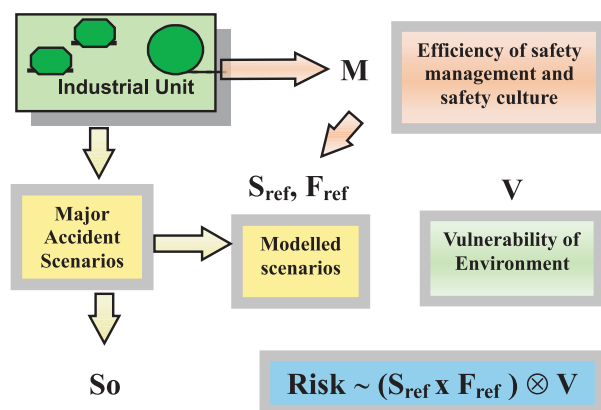

Fig. 1 Summary diagram of the ARAMIS methodology [2]

* Aleš Bernatík, Šárka Horehledřová, Petra Nevrlá

VŠB-Technical University of Ostrava, Faculty of Safety Engineering, Lumířova 13, 700 30 Ostrava-Výškovice, Czech Republic, Tel: +420 597 322 833, fax: +420 597 322 982, E-mail: ales.bernatik@vsb.cz

At present, the selection of those pieces of equipment, for safety of which the documentation in the area of major accident prevention is required, is being exercised on the basis of limit amounts of hazardous substances given in the Act No. 353/1999 of the Code. This rather simple procedure according to the cumulative formula brings advantages and also disadvantages. On the one hand, it decides unambiguously about placing the enterprise into the group A or B; however, on the other hand it does not give any information on a following risk to the environment. In some cases, the source of risk with an under-limit amount of hazardous substances located, e.g. in a densely populated area can represent a greater hazard than a rather large source with an over-limit amount situated outside residential zones.

That is why one of the goals of the submitted contribution is to increase awareness on these unclassified risk sources, because risk perception is one of the main conditions of accident prevention. The next objective is a proposal for suitable methods of risk assessment for these unclassified risk sources – in this case the testing of ARAMIS methodology applicability. As risk sources not subject to the legal effect of the Act No. 353/1999 of the Code on major accident prevention, e.g. food-processing complexes (breweries, dairies, meat combines), sports facilities (ice-stadiums, swimming pools) and further water treatment plants, storage areas of pressure vessels, pumping stations and storage tanks of LPG were identified.

2. MIMAH method

To determine the S index, or reference scenarios of accidents it is necessary to do two partial assessments according to the methods for the identification of risk sources designed by the ARAMIS project – MIMAH and MIRAS methods.

The goal of MIMAH is to identify potential scenarios of accidents that may occur in the industrial process. MIMAH defines the maximum dangerous potential in the piece of equipment. In this phase of assessment the scenarios are to be taken as the worst cases that can occur without considering any safety measures (including safety management).

2.1. Identification of Potential Risk Sources in the Enterprise

On the basis of information acquired from the inspection of the enterprise, a list of sources of risks of major accidents, in which hazardous chemical substances are manipulated, produced, used, etc. was prepared. Hazardous substances are designated by one or more R-phrases according to the official classification of hazardous substances. Results of this step are arranged into Table 1.

For the purpose of the identification of risk sources, 16 types of equipment are defined by this method; in our case study they are as follows: EQ3 - storage of fluids in small packages, EQ4 - pressure storage, EQ6 - atmospheric storage.

2.2. Selection of Major Risk Sources

This procedure is based on the VADE MECUM method from Belgium. Pieces of equipment containing hazardous substances are selected for the next assessment, if the quantity of hazardous substances is greater than the defined threshold quantity. This threshold quantity is determined depending upon the hazardous properties of the substances, their physical states and their position in relation to other hazardous pieces of equipment.

As a result of this part of the ARAMIS methodology (method of the selection of major risk sources), the following three major sources were selected for the next assessment: engine room for cooling (source No.1), LPG pumping station consisting of 2 storage tanks (source No. 2) and LFO storage unit (source No. 6). In the next steps, these sources will be assessed in accordance with the MIMAH method.

2.3. Association of a Critical Event

With each selected risk source, a critical event must be associated (CE – Critical Event). The critical event is defined as a leak of the content (LOC – Loss of Containment) of liquids from the piece of equipment, or for solid substances more specifically as

List of potential risk sources identified

Table 1

Hazardous substance	R-phrases classification	Amount (kg)	Name of equipment + type	Physical state of substance
1. Ammonia	T, N R10-23-50	22,000	engine room for cooling: EQ4	two-phase
2. Propane	F+ R12	4900	LPG pumping station: EQ4	two-phase
3. Acetylene	F+ R5-6-12	110	pressure vessels: EQ3	gas
4. Oxygen	O R8	179	pressure vessels: EQ3	gas
5. Diesel oil*	Xn R40	3200	locotractor depot: EQ3	liquid
6. Light fuel oil*	Xn R40	233,000	LFO storage unit: EQ6	liquid

*These substances were included into assessment although they are not classified as flammable substances.

a change in the physical state (LPI - Loss of Physical Integrity). The MIMAH method presupposes 12 critical events. For the association of the critical event with the major risk source, the following two matrices are used:

- the matrix of the type of equipment and 12 potential critical events
- the matrix of the physical state of substances and 12 potential critical events.

The result of this part of MIMAH method is the association of the following critical events with the selected risk sources:

- Source No. 1 - Engine room for cooling:
CE8 - Leak from the liquid pipe
- Source No. 2 - LPG pumping station:
CE10 - Catastrophic rupture
- Source No. 6 - LFO storage unit:
CE7 - Breach on the shell with liquid leak

2.4. Construction of "Bow-Tie" Diagram for Each Critical Event

The MIMAH methodology ended with the building of a complete bow-tie diagram for each selected piece of equipment. The bow-tie diagram is built by the association of the critical event with the corresponding fault tree on the left and the corresponding event tree on the right (see Fig. 2). These bow-tie diagrams must be understood as scenarios for major accident without considering any installed safety measures. The evaluation of safety systems forms a basis of MIRAS methodology application.

The result of MIMAH in the case study is the construction of three bow-tie diagrams for selected critical events that will be further assessed in the MIRAS part. With reference to the size of the diagram, they cannot be presented here.

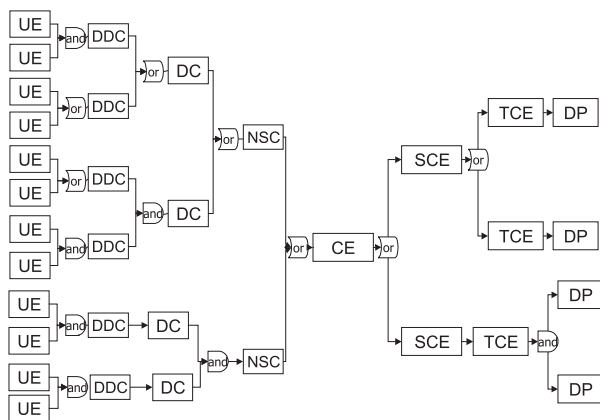

Fig. 2 A common 'bow-tie' diagram for one critical event [3]
Notes: UE - Undesirable Event, DDC - Detailed Direct Cause, DC - Direct Cause, NSC - Necessary and Sufficient Condition, CE - Critical Event, SCE - Secondary Critical Event, TCE - Tertiary Critical Event, DP - Dangerous Phenomena

3. MIRAS method

The objective of MIRAS is to select reference scenarios from the scenarios identified in the MIMAH part. The method rests on studying the influence of elements of safety and risk management on the scenarios selected in MIMAH. The reference accident scenarios (RAS) represent a real hazardous potential of the piece of equipment after considering safety systems, including management (see Fig. 3). In the MIRAS methodology, safety systems installed on the piece of equipment, the safety management system, the frequency of accident occurrence and the possible consequences of the accident are considered.

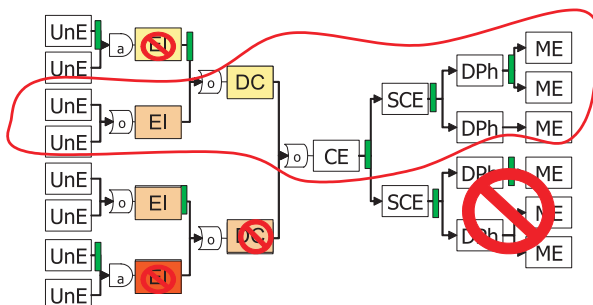

Fig. 3 Identification of reference accident scenarios - MIRAS [3]
Notes: UnE - Undesirable Event, EI - Initiating Event, DC - Direct Cause, CE - Critical Event, SCE - Secondary Critical Event, DP - Dangerous Phenomena, ME - Major Event

3.1. Determination of the Frequency of a Critical Event by Fault Tree Analysis

- This step is divided into 4 parts designated A - D.
- A: Determination of frequencies of initiating events
 - B: Determination of safety barriers in the fault trees
 - C: Assessment of the performances of safety barriers
 - D: Calculation of the frequency of the critical event

The output of the case study is formed by three fault trees with the determined frequencies of critical events; with reference to the size of the diagram, the fault tree for the risk source No. 2 - catastrophic rupture of LPG storage tanks (Figure 4) is illustrated in the next page as an example.

The result of this part of the MIRAS methodology is formed by the frequencies of critical events after taking into account safety barriers in the fault trees.

- For CE8 - great leak of ammonia from the pipe - 1.3×10^{-5} /year
- For CE10 - catastrophic rupture of the LPG storage tank - 2.1×10^{-6} /year
- For CE7 - large leak of LFO through the breach on the storage shell - 1.4×10^{-5} /year

In the case of the critical event frequency lower than 10^{-7} /year, there is no need to apply any subsequent steps.

3.2. Determination of Frequencies of Dangerous Phenomena

The objective of this step is to obtain the frequencies of all dangerous phenomena of selected critical events. The procedure is based on taking into account critical barriers in the event trees that may decrease the frequency or consequences of dangerous phenomena. From the results for the 3 selected critical events merely the event tree for the risk source - LPG storage tanks is illustrated as an example (Figure 5).

3.3. Evaluation of the Classes of Consequences of Dangerous Phenomena

At this phase of the methodology it is necessary to carry out the rough evaluation of consequences of dangerous phenomena. This qualitative evaluation of consequences is based on the classification of dangerous phenomena into 4 classes of consequences (C1 - C4), where the class C4 means the most severe effects on the health of people or on the environment. For particular dangerous phenomena the MIRAS methodology offers pre-defined classes of consequences that may be modified according to the efficiency of barriers limiting the leaking quantity or the effect of dangerous phenomena. Resulting classes of consequences are summarised in Table 2.

3.4. Selection of the Reference Accident Scenario

Reference scenarios are selected by means of a tool - risk matrix (see Figure 6).

Frequencies and classes of consequences of dangerous phenomena Table 2

No.	Dangerous phenomenon	Frequency	Class of consequences
1.	1a) Toxic cloud limited	6.5×10^{-6} /year	C2
	1b) Toxic cloud full	5.2×10^{-6} /year	C3
	1c) Environmental damage	1.3×10^{-6} /year	C2
2.	2a) Poolfire	2.1×10^{-7} /year	C2
	2b) VCE	1.4×10^{-6} /year	C3
	2c) Flashfire	1.4×10^{-6} /year	C3
	2d) Fireball	1×10^{-6} /year	C4
6.	6a) Poolfire	1.4×10^{-7} /year	C2

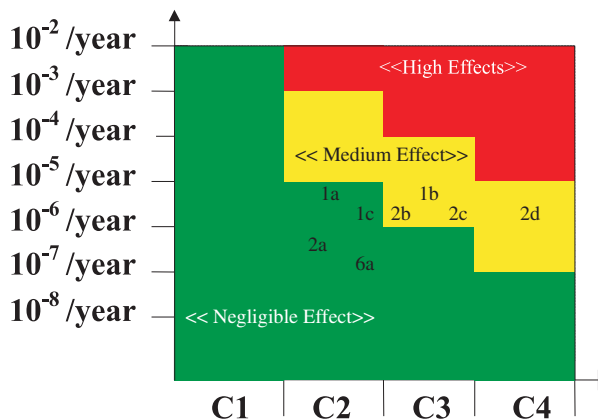

Fig. 6 Risk matrix with marked results

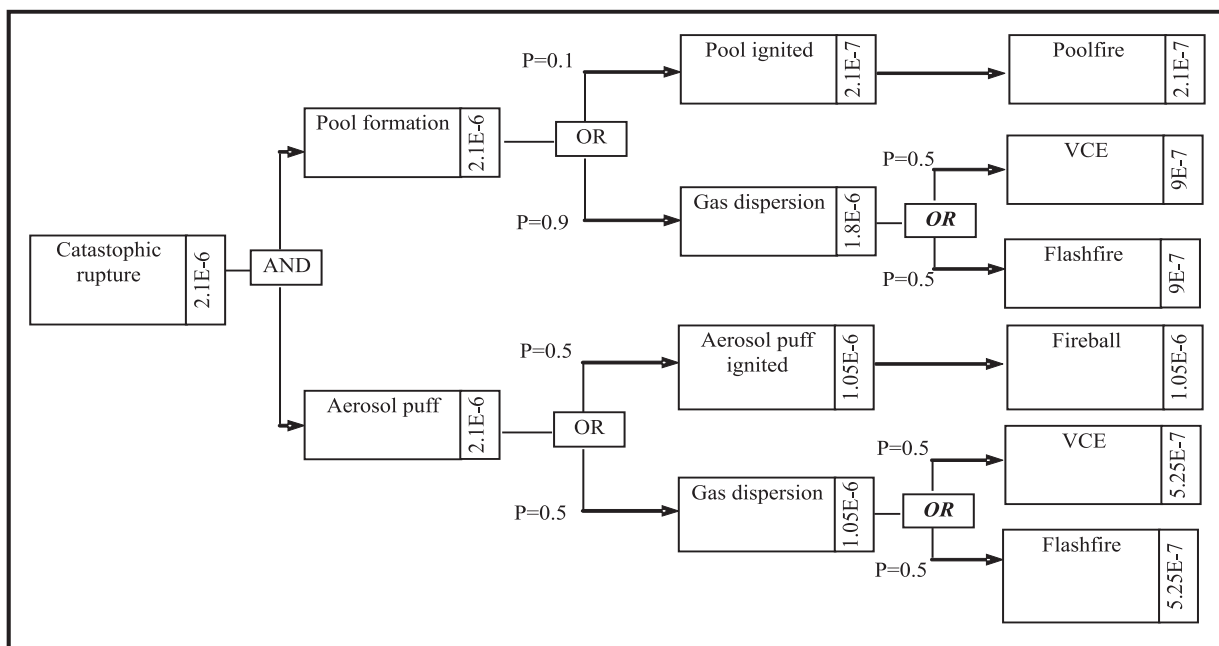

Fig. 5 Event tree with dangerous phenomena frequencies - rupture of the LPG storage

It is necessary to note that the risk matrix does not decide about risk acceptability in this phase of the methodology, but that it merely selects the reference accident scenarios that are further modelled for the purpose of severity calculation.

4. S Index

The goal of this part of the ARAMIS methodology is the determination of severity of reference accident scenarios by means of proposed parameters. Just the proposal for threshold values of specific effects of accidents is another significant benefit of the methodology, because any recommended values do not exist uniformly in the European Union yet. Following Table 3 summarises

MIRAS, in the industrial establishment unclassified under the SEVESO II Directive. The objective was to test the applicability of the methodology to such types of enterprises. The following conclusions may be drawn:

- ARAMIS enables the assessment of unclassified sources of risks.
- In many steps it facilitates, by pre-defined data, the procedure of detailed risk assessment.
- The making of the analysis is, however, demanding from the professional as well as temporal point of view.

For this reason, other works will be concentrated on considering a possibility of a simplification of the ARAMIS methodology for the purposes of unclassified sources of risk. Results obtained continuously from risk assessment indicate a necessity to manage

Defining threshold values for various levels of consequences [1]

Table 3

Level of effects	Radiation (kW/m ²)	Instantaneous radiation	Blast (mbar)	Missiles (%)	Toxic effects ⁽¹⁾	Description
d1	< 1.8	0 - 1/6 LFL	< 30	0	< TEEL-1	Small or non effects
d2	1.8 - 3	1/6 - 1/3 LFL	30 - 50		TEEL-1 - TEEL-2	Reversible effects
d3	3 - 5	1/3 - 1/2 LFL	50 - 140		TEEL-2 - TEEL-3	Irreversible effects
d4	> 5	≥ 0.5 LFL	> 140	100	> TEEL-3	Fatal consequences or domino effects

(1) TEEL -Temporary Emergency Exposure Limits - defined concentrations for an hour's exposure, identical with ERPG values, available for more than 2000 substances

Results of the distance of the range of dangerous phenomena for CE10 - LPG storage tanks

Table 4

Critical event	CE10	Frequency	2.1E-06				
Dang. phenomeno		d1	d2	d3	d4	Frequency	Type
VCE	2b	260	165	75	45	1.4E-06	Overpres.
Flashfire	2c	72	72	68	35	1.4E-06	Heat rad.
Fireball	2d	430	330	255	195	1.0E-06	Overpres.

values corresponding to four levels of consequences. Calculations of distance (radius of affected area) for specific levels were executed by the Dutch model EFFECTS 5.5. Following Table 4 gives an example of results in the form of distances (in meters) for specific levels of consequences d1 - d4 and for each dangerous phenomenon selected as a reference accident scenario. The type of consequences expresses one of the four possible serious effects of the accident (heat radiation, overpressure, fragments, toxic effects).

the risks and those unclassified sources of risks that at present are not included in legal regulations from the point of view of prevention, but in spite of this they can represent significant risks of major accidents.

This contribution was prepared as a part of dealing with the grant project GAČR 104/02/D070 titled in English "Design of a Methodology for the Assessment of Major-Accidents Risks in the Context of the European IPPC Directive and the Amendment to the SEVESO II Directive". The goal of the grant project is the creation of a methodical procedure for the management of risks of unclassified risk sources.

5. Conclusion

The case study describes the application of the ARAMIS methodology, especially of its introductory part, MIMAH and

References

- [1] DELVOSALLE, C., FIEVEZ, C., PIPART, A.: *ARAMIS Project*, Deliverable D.1.C., 2004.
- [2] HOURTOLOU, D., SALVI, O.: *ARAMIS project: Achievement of the Integrated Methodology and Discussion about Its Usability from the Case Studies Carried Out on Real Test Seveso II Sites, Loss Prevention and Safety Promotion*; Proc. Intern. Symp., Prague, 1-3 June 2004.
- [3] NEVRLÝ, V.: *Comparison of Methods of Major Accident Risk Assessment*, Diploma thesis, VŠB-TUO, 2004.
- [4] <http://aramis.jrc.it>

Roman Jašek *

THE INFORMATION SECURITY OF ENTERPRISES AND CITIZENS' SECURITY CONTEXT

The aim of the article to show the analogical procedures encountered while dealing with the security of a company or personal security. Security of Information Systems relates closely to modern-day life and the solution of crisis situations is but one part. It does not matter whether the reason of the crisis is the human factor (purposely or unpremeditated) or even a technical failure. All systems must be able to switch to reserves within real time in order to ensure process continuity. While this article is about systems in the economic (financial) field, the same rules apply in government crisis management at any level. Consequently, the rule of Crisis Management in contemporary society is essential.

Introduction

When resolving questions regarding information security, we encounter many approaches which we, with all sense of gravity, perceive as parallels in the domain of Crisis Management and the citizens' security. In every case, the aim is always a question of protecting something – anything that makes sense to protect and which can be considered to be threatened in some way (e.g. unauthorised access to a database, manipulations of data, assumed identities, misuse of communications possibilities of networks for illegal activities, etc., ... and ending with terrorism).

From the view above, it is therefore possible to say that information security is a specific case of citizens' security oriented on the protection of tangible and intangible commodities. The resolution of such a conception of the problems and issues involved in information is, therefore, highly important and beneficial for society at large.

Security management activities under unusual circumstances

One of the first tasks of security management is to establish how the security situation will be classified as a security incident as well as how it should be resolved. Simply put, it is necessary to establish the borders defining when the problem will be the concern of the security specialist in conjunction with the Managing Director and which situations should be resolved at the consultant and specialist levels.

The resolution of grave security incidents classified as catastrophes and accidents are usually resolved in specially-prepared

documents (i.e. crisis plans or contingency measures based on the same) [4] [5].

In Security Policies, the category of security incident and the duties of each employee must be clearly set out, as follows:

- Proactively circumventing the security incident.
- To act in a decisive manner and in compliance with the instructions of the security management personnel in the discovery and liquidation of consequences of security incidents at all three levels of the security system²⁾.
- To directly inform each and every breach of the security policy to the appropriate security management system employee.
- The security policies or regulations based upon them shall be openly publicised by the person in charge of third-level security management issues in each workplace (department, office, organisational structure unit, etc).

In case of an incident arising, the security management team should proceed in line with the following schema:

- The employee who discovers the security incident must immediately inform the employees of the second and third security management levels.
- This should be in writing (or verbally while ensuring a written record) in one's own special log and the immediate securing of the place (or technical equipment), where the security incident occurred. This announcement is classified as a *Confidential Document*.
- If a third-level security management employee has been informed – the facts regarding the discovery must be passed on as quickly as possible to a second-level security management employee – into whose competence this security incident falls.
- This second-level security management employee must ensure a complete security analysis of the incident and establish the

* Roman Jašek

Department of Informatics and Statistics, Faculty of Management and Economics, Mostní 5139, 76001 Zlín, Czech Republic,
E-mail: jasek@fame.utb.cz, Tel : +420 576 037 436

²⁾ The first level is represented by the position of Head of Security, who is directly subordinate to the Managing Director himself. The second level represents the position of security specialists for: administration, personnel issues, technical and plant and machinery issues, information (data) and cryptographic security. The third-level (down) represents the relevant position of the security consultants (their role resides in the collection of information and consultations in normal operational activities).

direct measures undertaken to resolve the issue. If the measure(s) exceed their powers and competencies, they must inform the first-level security management employee (the Head of Security) about this event as soon as possible, who will ensure the taking of adequate measures.

- Second-level security management employees should pass on a summary of information about security incidents to the chief security managers at proscribed intervals (e.g. once every three months) for their operational and strategic importance.
- Each and every employee should have the right to contact and confide in a security management team employee at the level of their choice if they suspect that there is a threat to the security of the information they deal with.

Crisis situation management plans

Security, like a coin, has two sides – the protection of information and its accessibility; and the mastery of exceptional situations – this is precisely to be found in the preservation of its accessibility – therefore, not only “fences” and passwords but also back-ups onto storage disks; planning; etc. The mastery of *Exceptional Circumstances (EC)* therefore may only be successful where it respects to the letter the important elements of crisis management, i.e. overall security policies, and especially – *Systemic Systems Security Policies*³⁾ (SSSP). Without the below-mentioned documents, it is only possible to master an EC in the sense of generally-applicable principles and bearing in mind the specific procedures prevailing in differing organisations [1] [6].

The resolution of exceptional circumstances (events) is usually reflected in three basic key documents, which are hierarchically linked together. In the first instance, we must interest ourselves in how to manage the security aspects of business life. Then, we must plan ways in which we can remain under our specific conditions as long and as effectively as possible. And finally, we must know how to survive even the most unfavourable of circumstances that we could possibly meet. Sometimes, the following terminology is used:

- *Business Continuity Management (BCM)* – Management of the unbroken continuity of a business’ commercial activities).
- *Business Continuity Plan (BCP)* – Planning for uninterrupted continuity in business operations).
- *Disaster Recovery Plan (DRP)* – Planning for remedial activities for situations occurring under exceptional circumstances).

The above-mentioned documents provide a starting-point at the level of the organisation as a whole, and define the critical production domains, determine procedures and ensure their compliance in the event of occurrences of exceptional circumstances; and set out in detail the resolution of critical and exceptional circumstances in the form of concrete approaches and procedures. When designing a manual for the mastery of EC, it is necessary to

take the following basic stages in the resolution of exceptional circumstances into account:

Normal operations prior to the occurrence of an exceptional circumstance:

1. *Reactions to an exceptional circumstance.*
2. *The renewal of basic functions after an exceptional circumstance.*
3. *Interim operations.*
4. *Restoring full services and operations.*
5. *Normal operations after renewal of full services and operations functions.*
6. *Normal operations prior to the occurrence of an exceptional circumstance.*

During normal operations, we must gradually create and fulfil conditions that enable execution of crisis plans – whether in “normal” (main) or reserve facilities with Main Spaces and Resources (MSRF) or of Reserve Spaces and Resources and Equipment (RSREF).

These mainly are:

- Data and programme back-up and storage.
- Contracted Guaranteed (Technical) Support.
- Reserve and back-up space and their repairs and maintenance.
- Archive documents and media.

Obviously, in such a sense the RSREF must provide not only for the fulfilment of the third point above (i.e. reserve and back-up space and repairs and maintenance), but also the following point, i.e. the unbroken continuity of the archiving of documents and media [2] [3] [8].

Reactions to an exceptional circumstance

Exceptional circumstances do not only cover fires or local flooding, but also destructions caused by explosions, industrial influences, sabotage, premeditated or unpremeditated damages, etc. In reality however, the site is not usually guarded by sentries and only the ingress points from public domain external sources are subjected to scrutiny – otherwise, the compound is only guarded when patrol cars pass by or personnel within the compound patrol on foot⁴⁾, and a time-delayed sabotage act for instance could create wide ranging damage at a time when the attacker is long gone. It is perfectly possible to carry some form of destructive materials into the building and to place them precisely where they can do the greatest degree of harm and destruction, and this can be carried off without attracting any special attention whatsoever.

Immediate activities undertaken by individuals and technical equipment in response to the occurrence of an exceptional circumstance are, for instance, the reactions of:

- A person directly impacted by the situation.

³⁾ Sometimes also called the Information Systems Security Policy (ISSP).

⁴⁾ Here, we are thinking of normal (floor) space, i.e. not fitted with any form of industrial tracking technical equipment.

- A top-echelon employee (Management).
- An IT employee.
- Technical equipment.

From the RSREF point of view, the reaction of the IT employees is important in connection with the reaction of users directly affected by the event and especially in reaction to events of a technical character. Activities undertaken immediately after the occurrence of an EC directly influence further approaches to the resolution of the crisis state. For example, after the intervention of the Fire Brigade, it is unlikely that production machinery and equipment or production media operations will recommence within a period of less than 12 hours, and it is necessary to take this fact into consideration when planning alternative activities.

A component of the transformation process is the transport and installation of larger quantities of materials, which not only require the construction of external access roads with sufficient load-bearing capacities, but additionally, sufficiently suitably-dimensioned passageways and corridors. This issue is inseparably interconnected with the implementation of the DRP itself to an emergency stand-by state, i.e. equipping oneself with appropriate technological equipment, furniture, etc.

Renewal of basic functions after an Exceptional Circumstance

Renewal of basic functions must include:

- Transition to back-up approaches and procedures (e.g. the manual processing of information), before the basic functions and services in the RSREF are brought on-line.
- Bringing on-line the RSREF (communication-links, activation of alternate power resources and media, etc.).
- Renewal of the basic IS functions of the RSREF.
- Working in the back-up regime.

When mastering an EC, it is important that the transition to the back-up operating regime should reflect as fully as possible the fulfilment of the basic functions and, especially, that their renewal in the back-up sites must be supported by the initiation of the basic state (i.e. at the moment of occurrence of an EC on the BCP) from reserve backup media, etc. Communications must be renewed as soon as possible between the productive departments (i.e. users, production, etc.) and the team which will renew and manage the basic functioning of DRP (Crisis Management Team).

In the first phase, the Crisis Management team must, therefore, be capable of activating not only technical equipment and technical communications paths (e.g. networks, the Internet, etc), but also master Head Office activities on the front lines, acquiring back-up media, their installation and bringing on-line, and especially, those activities that enable a transition back to normal full operational activities in the original locality of the DRP. From this it must be clear that the operations of the RSREF must also be managed as regards the continuous creation of operational backups and reserves and their safe storage [11][12].

Interim operations

Interim operations must enable the execution or accessibility of functions that are specified in the BCP and DRP. These are the minimum number of functions that need to be preserved to cover basic activities, i.e. to be able to, at least in part, continue to manufacture and sell.

From the above, it is clear that mastery of the EC from this point of view is, lacking the requisite documents (the BCP, DRP, CBP, and SBP), only a generalised concept and is further burdened by a certain degree of subjectivity.

Restoring full services and operations

The restoration of full services and operations is usually the least-considered part of the whole chain. What this means is that, in accord with the BCP and DRP, plans are elaborated and later implemented for the return to the original HPP and the renewal or restoration of full operations after the transition from the RSRPF. This requires above all:

- The execution of previously established technical and organisational measures in line with the BCP and DRP.
- The gradual handover and transfer of tasks (activities).
- Replacement of the materials consumed or destroyed in the course of the RSRPF, and others.

The RSREF must finish its functions by the renewal or restoration of conditions for the full operation of the HPP and the preparations for the new handover of operations activities subsequent to the EC.

As a function of the RSRPF as a back-up reserve centre, it follows that upon liquidation of the EC, it is not only necessary to support the renewal and restoration of full operations through the handover of documentation and media, but also to assess all of the activities undertaken by the RSRPF. This should be followed by the updating of the CBP, SBP, BCP and DRP action plans, as required [7] [9].

This area is both theoretically and practically demanding and complicated, and one-hundred percent effectiveness of the measures designed for mastery of crisis situations can never be guaranteed. We can only test the plans repeatedly to verify their applicability in practice. The possibility of using the services of specialised companies is an issue – not only will they elaborate the requisite documentation (or eventually, help in their creation), but they will prepare for the conditions in their own environments in order to be able to take-over operations without a hitch using their own technical equipment and thus to reduce any damages incurred as a consequence of the non-functioning of one's own production system [10].

All of this however, requires the construction of a functionally equivalent environment, which is – for the majority of operators of information systems, absolutely uneconomical – and for this

very reason, impossible to put into practice. For these reasons, these specialised companies usually have corresponding environments pre-prepared for a variety of users and thanks to the low probability of a crisis actually occurring, two such systems exist concurrently on the market today. In the case of crisis situations and the crash of these two systems at the same time, there also currently exist contracts between other providers of similar such services, where these assume a portion of the burden of obligation. For the global network, this is not a technical problem. It does however require increased protection of information since data from more than one user can co-exist on one system at the same time, and also, a greater variety of processes will most probably operate on the data with varying degrees of sensitivity. For each and every such "backed-up" system a specific security project is required, to be approved prior to the conclusion of contracts for reserve /back-up operational capacity.

Conclusion - Summary

The security of information systems is closely linked to contemporary life and the resolution of crisis situations forms an integral part of it. It is absolutely all one whether or not the crisis occurs as the consequence or influence of failures of the human factor, premeditated or not, or due to a technical failure. All of the systems must be capable in real-time of immediately switching over to back-up systems and thus to ensure the continuity of operational processes. In this article, we have talked and written about systems with an orientation on economic (financial) areas; nevertheless, the same rules also apply to the elements of state's crisis management teams at whatever level.

The role of crisis management as outlined above is therefore absolutely indispensable in contemporary society for the above-mentioned reasons.

References

- [1] BENDA, R., BRÁZDILOVÁ, M.: *The Role of Knowledge Management in Increasing the Competitive Abilities of Enterprises (in Czech)*, Internet a konkurenceschopnost podniku VI. ročník konference, Zlín, Univerzita Tomáše Bati ve Zlíně, 2004
- [2] BRÁZDILOVÁ, M.: *Information Resources for the Needs of Competitive Espionage (in Czech)*, In: Internet a konkurenceschopnost podniku, VI. ročník konference, Zlín, Univerzita Tomáše Bati ve Zlíně, 2004
- [3] BLAŽEK, V.: *The Continuity of Transformation Processes and the Role of Universities and the Long-term Development Goals of the Police Academy in Bratislava (in Slovak)*, In: Policajná teória a prax, Bratislava, 2003.
- [4] ČANDÍK, M.: *Site Security II. (in Czech)*, Zlín, 2004
- [5] HOFREITER, L.: *Security, Security Risks and Threats (in Slovak)*, Žilinská univerzita, EDIS-Publishing ŽU, Žilina, 2004
- [6] KORZENIOWSKI, L.: *Security Management (in Polish)*, Study Programme taught at: Szkoła Wyzsza, Przedmioty Specjalizacyjne, European Association for Security, Krakow, 2004
- [7] KOZÁK, V., ROSMAN, P. JAŠEK, R.: *Facts about Firms Security in Central of Moravia (in Czech)*, Využitie databáz v marketingu, Ekonomická univerzita v Bratislavě, 2004
- [8] KOZAK, V., JASEK, R., MELICHAREK, Z., CHERNEL, A.: *Economic Inteligence and Espionage*, In: Edukacja ekologiczna oraz determinanty rozwoju regionalnego i bezpieczeństwa biznesu w jednoczacej Europie, Wysza Skola Zarzadzania w Slupsku, Slupsk, 2004
- [9] KLÍMEK, P.: *Econometrics (in Czech)*, Fakulta managementu a ekonomiky, TBU in Zlín, 2004
- [10] ŠIMÁK, L.: *Crisis Management in Public sector Administration (in Slovak)*, Žilinská University in Žilíně, Fakulta špeciálneho inžinierstva, Žilina, 1998
- [11] TOMASZEWSKI, J.: *Economic and Legal Problems in Electronic Trade and Company Competitiveness*, In: Internet a konkurenceschopnost podniku, VI. ročník konference, Zlín, 2005
- [12] VOLNÁ, E.: *Neural Networks and Cryptography*, In Book of Abstracts of the Central-European Conference on Cryptology, Tatracypt '01, Liptovský Ján, Slovakia 2001.

Petr Linhart *

CURRENT TRENDS IN POPULATION PROTECTION IN EUROPE AND THEIR RESEARCH SUPPORT IN THE CZECH REPUBLIC

In the contribution, on the base of a systematic study of evolution trends in the field of population protection in some European countries, current looks on a wide-spectral approach of this issue were generalized. The contribution deals with: Protection of population as an integrated system, Risks and threats, Mission, Main tasks, Powers, Rescue entities, Management structures, Service model, Education and training, Protective infrastructure, and International co-operation. In connection with the necessity of research support of measures for population protection, the current state in this issue in the Czech Republic was described.

1. The most important elements in protection of population

Protection of Population as an Integrated System

In some countries (including the Czech Republic) a term *protection of population* has been already introduced (or its introduction is under preparation) into their legal system as a certain “roofing” name for an integrated system. The current framework of protection of population in many European countries can be generally demonstrated by the following scheme:

Kind of events	Daily events	Disasters and emergencies	Armed conflicts
Field of activity	Prevention of damage	Protection against disasters (Natural disasters, industrial accidents)	Civil protection (Protection of population in wartime)
Competence	Self-government, lower level of state administration		State
Rescue entities	Fire fighters → Health rescue work Auxiliary services National forces Armed forces		

Scheme No.1: Structure of protection of population

In fact, three kinds of events can be distinguished, namely so-called daily events, disasters and emergencies, and armed conflicts. Under the term *daily events* we understand traffic accidents, railway traffic accidents, plane crashes, construction crashes, explosions and breakdowns of engineering communications and service pipelines, salvage of persons in various situations, etc. This means the events with a small number of health and irrecoverable losses with

low material damage and a minimal impact on the infrastructure of a society and the environment. The field of activities in case of daily events can be generally called *damage prevention*.

Disasters and emergencies include natural and industrial disasters with a great number of health and irrecoverable losses, with large material damages, with massive impact on the infrastructure of a society, life of population and environment. Most of all they represent vast floods, landslides, earthquakes, vast surface fires, snow avalanches, breakdowns of industrial production plants and transportation systems with the escape of gaseous toxicants and radioactive agents. The field of activities in case of disasters and emergencies is generally called *protection against disasters*.

Armed conflicts can be of a national character (civil or ethnic wars), war conflicts between two sovereign states or a coalition war between two military groups of sovereign states may occur. The field of activities during armed conflicts is called *civil protection (defence)* in terms of the international humanitarian law within the meaning of Additional Protocols I and II to Geneva Treaties of 1949 on protection of armed conflict victims adopted in Geneva in 1977.

Risks and Threats in a Non-military Field

New threats and some enduring long-term risks began to appear in relation with the end of cold war.

A permanent threat is represented by states, non-governmental groups, and organisations not respecting the international law and enforcing their interests by war, violence and encroaching on human rights. Ethnic and religious conflicts, economic and social problems and violation of human rights inside the states are the sources for regional crises.

Threat of use of mass destruction weapons cannot be excluded and the range of entities disposing of these weapons or willing to

* Petr Linhart

Population Protection Institute - Ministry of Interior, General Directorate of Fire & Rescue Service of the Czech Republic,
E-mail: petr.linhart@ioolb.izscr.cz

acquire them is still growing. Situations when individuals or non-governmental entities acquire these weapons are the most dangerous.

Frequent and extraordinary dangerous phenomenon is terrorism and extremism in many regions. Real threat is a possibility of using weapons of mass destruction for duress. The most serious threat for the European security is the situation in South-Eastern Europe, Near East and North Africa.

Regional conflicts and differences in the standard of living are the reasons for political and economic migration. Negative reactions of some groups of inhabitants of target countries against immigrants push these people aside of the society and often throw them to individual or organised criminality.

Communication capabilities that open a space for organised criminality, drug trade and terrorism bring new risks. There exist real threats of subversive activity based on breaking into electronic and information systems and their interference.

Global risk is caused by an uneven development and still growing gap between the standard of living in Euro-Atlantic region and a limited group of other highly developed countries and countries in Southern Hemisphere.

An individual chapter is a negative impact on the environment as a result of anthropogenic activities resulting in natural disasters, climatic changes, a loss of drinking water, epidemics, and a lot of subsequent and accompanying negative events.

Most European countries recognize, consider as serious and get ready for the risks as follows:

- Natural disasters;
- Industrial disasters;
- Damaged environment as a result of anthropogenic activity;
- Failures in provisioning;
- Epidemics;
- Mass migration;
- Organised criminality;
- Terrorism and extremism of all kinds;
- Drug trade;
- Uncontrollable proliferation of mass destruction weapons;
- International conflicts outside Europe as well as in its vicinity (Near East).

Reassessment of a risk at the very end of the last century also resulted in a changed approach to protection of population. This was proved especially by transferring from protection of population against war effects (civil protection, civil defence) to protection against the above-mentioned risks in peacetime. Practical consequence of such changed priorities in protection of population was the revision of respective legislation standards (laws in particular), total dissolution or maximal minimisation of fixed structures intended in case of war, limitation especially of state finances primarily in the material field by devolving of powers from the level of the state to the level of lower administration and self-gov-

ernment levels, stopped or very limited building of protective infrastructure and reduced obligatory service (in countries where it had been introduced).

Mission

In the last quarter of the twentieth century the centre of measures within the framework of protection of population began to move from an armed conflict "segment" (civil protection, civil defence in terms of international humanitarian law) to a "segment" of disasters and emergencies (protection against disasters) in Europe and in the world. These tendencies became concrete especially after a *meeting of the European Union ministers held in 1986* which laid the bases for a common policy of the European Union in the field of *civil protection* (this name was adopted for this activity in the E.U.), and after the adoption of the *Roman Treaty by the NATO states in 1991* where the priorities were changed from the military solution to a political one (change of a NATO strategy concept). With a decreasing probability of a vast international and global military conflict and, on the other hand, with the increasing industrialisation of the society, affects on the climate and gradual globalisation of the world with all its negative consequences, the field of protection against disasters gains its dominant position within the protection of population.

The mission of protection of population is similar in all compared countries. They usually speak about protection of population and living conditions, protection and salvation of persons "in disasters and emergencies", "special emergencies", "under all conditions", "in peacetime and in case of defence" or "survival of emergencies in any way". Thereof flows that majority of countries focus on protection of population today, especially against natural disasters, technical disasters and emergencies.

The systems of population protection in the compared countries include different components according to their own conception. In particular, the task how to manage daily events, disasters, and emergencies and planning in case of war differ in every country.

Different designation of the systems called protection of population, civil protection, civil defence or civil security does not mean that these are principally different systems. Today, all countries focus on prevention and management of natural disasters, technical disasters and emergencies in the field of protection of population. All countries take measures to protect population in disasters, emergencies and in case of war with sources designed for use in daily events. There are tendencies that the *same*, especially *resolute management* of organisational and executive *structures* is able to secure tasks both in daily events and, having been duly reinforced, in disasters and emergencies or war, as the case might occur. There is also a tendency to achieve the most possible *integration* of individual rescue entities in daily events.

The differences consist, first of all, in setting tasks to organisations intended for engagement, and in the particularities in measures taken by the individual countries to enforce the resources

intended for engagement. In Switzerland, Germany and France, second-plan resources are available for engagement in disasters. Armed forces provide subsidiary support in all countries. Neutral states like Switzerland, Finland and Sweden take extensive measures in case of war (including protective infrastructure). Compared to other countries, Sweden and Switzerland take the most extensive measures in the field of protection of population.

Main Tasks

In *daily events* the tasks performed by rescue first-plan branches in an integrated system within their professional specification are aimed primarily at salvage of persons and property. Performance of routine tasks does not require extensive planning as a rule and standard routine activities are usually sufficient for coping with tasks successfully.

In case of *disasters and emergencies and armed conflicts, in particular*, there are a lot of tasks requiring extensive preparation, planning, material resources and finances. The tasks of population protection in an armed conflict (civil protection, civil defence) are specified by Additional Protocols I and II to Geneva Treaties of 1949, ratified by all countries. However, these protocols cover only armed conflicts. During last twenty years a lot of tasks contained therein were being applied in peacetime during various disasters and emergencies or vice versa, a lot of measures intended for protection of population against disasters and emergencies could be implemented in war after having been enhanced and replenished.

In most European countries, at present, the *tasks* are as follows:

- Warning and information system
- Principles of behaviour
- Building of protective infrastructure
- Health protection
- Self-protection and mutual aid
- Protection of cultural values

The tasks listed above are the most typical ones for majority of European countries, but specific features exist in almost each country.

In some countries (Germany), warning and information system was split into peacetime and wartime both in terms of competences (the state in case of war and federal lands in peacetime) and technical resources (sirens in peacetime and mass media in wartime); in lot of countries (Sweden, Switzerland, etc), a single organisational and technical system exists for both situations.

The greatest differences are in building of protective infrastructure (Switzerland – 100% shelter coverage, France – has no shelters and does not build them). This arises especially from financial reasons since this method of population protection requires high budget means.

Protection of cultural values is more declared in some countries (Germany), while in others (e.g. in Switzerland) it is performed

both in terms of documentation and implementation (shelters designed for mobile cultural assets).

Some countries (e.g. Austria) pay extraordinary attention, both in the theoretical and practical respect, to protection of population against ionising radiation in peacetime in case of a breakdown in some of nuclear power plants located in the vicinity of Austria.

Other countries (e.g. France) also include tasks related to environmental protection into protection of population, especially in connection with the damage of the environment in case of vast disasters and emergencies.

The other way round, so-called individual chemical protection does not belong among the tasks of population protection in Europe, i.e. protective masks or skin protective equipment supplied from the state resources. This is a relic in post-communistic states, though such means make a part of shelters as equipment for the sheltered in some northern countries (Sweden). The states storing such equipment in large quantities for population try to minimise its number and secure it primarily for children, youth, social sphere, and industrialised and endangered areas (in the vicinity of chemical plants and nuclear power plants in particular). Nothing prevents people from selecting such equipment from a rich commercial offer and from acquiring it at their own cost.

Powers

Powers in individual fields of activity within protection of population depend on administration structure of a given state. Powers can be generally divided into following levels:

- Central (state, confederate state, federative state)
- Land (federal lands in the states with federal system, cantons)
- Higher middle (regions, provinces, zones)
- Lower middle (districts, departments)
- Municipal (communities, towns, cities)

It generally holds that the smaller “adverse” event in relation to population, the lower administration level is competent and also responsible for its management and vice versa. However, especially in the cities with a four-level or five-level administration structure, this rule does not hold completely and deviations towards higher or lower levels of management appear.

Powers for solving *daily events* are mostly at the lowest level of management, i.e. municipal self-government (Scandinavian countries, Germany). There is a great difference between a community in the German and Scandinavian conception from the territorial point of view, since due to urbanisation of the landscape, the community cadastral area in Finland or Sweden is many times larger than in Germany and density in a built-up area is in an opposite ratio. In Switzerland and Austria the differences in the powers between communities and cantons or communities and land districts are not so apparent in this field. In France the main centre of gravity of powers is at the level of department in daily events too.

In case of *disasters and emergencies*, the powers for their solving and also their prevention always lay on the intermediate level of management. For example: federal lands in the states with federal structure (Germany, Austria), cantons in Switzerland, and departments supported by defence zone in France. Scandinavian countries represent a certain exception where the intermediate level of management is suppressed and communities hold the responsibility with direct support of the state. For example in Sweden, regions play secondary role in this field and they perform their tasks only in case of a breakdown of nuclear power plants. However, in all countries the state plays a supporting and especially a co-ordinating role in vast disasters and emergencies, and events exceeding the borders of federal lands, cantons, departments, etc., or inflicting simultaneously more of the above mentioned territorial units.

The state is always responsible for protection of population *in case of war* (civil protection, civil defence) regardless the character of an armed conflict. Yet, in peacetime, the state takes a lot of organisational, material, technical, and personnel measures to protect population in case of war depending on concrete conditions (historical, geographical and social ones) and most of all depending on its financial possibilities. The state in some countries (Germany) got rid of some powers in this field in favour of federal lands with the aim to reduce costs which had a negative impact especially after September 11, 2001 in the U.S.A. Currently there has been a tendency to re-enforce the role of the federal state in the field of protection of population in Germany.

Rescue Entities

Rescue entities within protection of population can be divided as follows:

- First-plan
- Second-plan
- Acting on a subsidiary principle

First-plan resources intended for protection of population are especially fire fighters, health rescue workers, and auxiliary services. Fire fighters are intended to fight against fires, prevent damages, salvage people and provide technical assistance. They participate in rapid health aid and transport of patients in some countries (France, some federal lands in Germany). Fire fighters' department is a member of an ambulance in Scandinavian countries.

Health rescue workers have powers to salvage persons, provide rapid health aid, transport patients and are directly linked to acute bed fund in health facilities.

In German-speaking countries (Germany, Austria), so-called auxiliary services play an important role even within first-level units. To name some of them: the Red Cross, Geneva Rescue Service, Johannite Accident Aid, Operating Samaritan Union and German Society for Life Salvage. They are designated primarily for salvage of lives and health of persons. The Austrian Red Cross is even a decisive first-plan health rescue organisation with a sufficient number of professionals, hardware and transport means. A lot of

other profession-oriented organisations as e.g. mountain service (Alpine countries), cave rescue service, organisations with rescue dogs and various charitable and clerical organisations should be associated with the most important ones. Their activities within the area of protection of population is defined by law (e.g. in Germany).

Special units intended for using during disasters and emergencies act as *second-plan* forces and resources in some countries. In Germany, this is so called Technical Auxiliary Service (hereinafter referred to as the "THW") which is an independent federal institute within the Federal Ministry of Interior with its branches in most of federal lands and with more than 600 bases. The task of these units of different specialisation is, first of all, provision of technical assistance in vast disasters even in abroad. In France, Denmark, and Slovakia, special military units consisting of regular soldiers, and conscripts (executing their service on the basis of Compulsory Service Act) are intended to support the first-plan units to cope with vast disasters. These units are detached from Armed Forces and are responsible to the Ministry of Interior and contain the elements intended for liquidation of natural and anthropogenic disasters. They are also able to provide health aid to victims (engineer troops, fire-fighting units, chemical units and health units). In Switzerland persons subjected to compulsory service in civil protection, regularly educated and trained, are designed for this activity. The Switzerland legislation makes possible, within devolved power that the city mayors may call out such persons to cope with natural and anthropogenic disasters within the civil protection field.

In most countries, there has been a current tendency to integrate especially the first-plan units into integrated rescue systems under common management.

Management structures at a state level

Engagement of rescue units in daily events usually does not require any extensive planning and material measures. Operative routine of individual integrated first-plan units designed for coping with these events is sufficient.

Protection of population during disasters and emergencies, especially in war, requires extensive planning, material, financial and personnel preparation. As a rule, all these activities are secured from the top administrative levels of the given state (land level, state level). Individual professional activities are within the powers of the individual government departments; *within the government department of interior or an armed forces structure, the resolute structures for these purposes are built and usually dispose of total control and have a co-ordinating role.*

In the states with a typical federalist principle of management and administrative structure (Germany, Austria, Switzerland), final responsibility for protection of population during disasters and emergencies lays on federal lands (Germany, Austria) and cantons (Switzerland) according to a respective land (canton) legislation.

Respective resolute management structures were built for this purpose on the level of land ministries of interior and canton administration. If disasters or emergencies are so vast that they inflict several federal lands and more cantons, and if the war begins, protection of population (usually civil protection in war) is within the power of the state. Resolute organisational and management structures are built for this purpose on the state level. (Civil Protection Department of the Federal Administration Office of the Federal Ministry of Interior in Germany, Civil Protection Department of the Federal Ministry of Interior in Austria, Federal Civil Protection Office of the Ministry of Defence, Protection of Population and Sport in Switzerland).

In countries with a centralised structure (Scandinavian countries, France, etc.), the final responsibility for protection of population in disasters and emergencies and in war (civil protection) is on the resolute structures built for this purpose by the government department of interior or defence as a rule: Rescue Department of the Ministry of Interior in Finland, Civil Readiness Office and Rescue Services Office of the Ministry of Defence in Sweden, Office for Management under Threat of the Ministry of Interior in Denmark, Directorate of Defence and Civil Security of the Ministry of Interior in France. Within these resolute structures there are also second-plan rescue units with nation-wide competence in some countries (Denmark, France).

To secure the tasks of civil protection or defence (protection of population in war), the above mentioned central management structures are additionally staffed so as to cope with all planned tasks in case of a war conflict. Their activity is usually supported by flexible structures (various inter-government department advisory, information and co-ordination committees consisting of representatives of various involved ministries).

Service Model

Service in rescue units within the area of protection of population is based on:

- Service obligation - implemented on so called service days (hereinafter referred to as the service days)
- Voluntarism - implemented on service days without financial or legal stimulation
- Professionalism - implemented by service days paid by the market price

“Pure” model of service does not practically exist in rescue units in individual European countries; there is always a prevailing part of one of the above listed forms.

Extensive *service obligation* (militia system) is used mainly in Switzerland with cc 75 % of fire fighters and 100 % members of civil protection organisations as a second-plan element of engagement. In France there are Military rescue units (UIISC) with a nation-wide power acting on the basis of service obligation. In Denmark there are regional bases of the National Rescue Corps and the Slovak Republic disposes of Civil Protection Rescue

Brigades of the Civil Protection Office at the Ministry of Interior of the Slovak Republic.

The principle of *voluntarism* is applied mainly in Germany and Austria where the fire fighters and auxiliary services or rescue organisations are organised almost exclusively on the basis of voluntarism. This principle is enforced partly by the fact that the fire fighters in both countries must create part of their financial charges by their own means, and it further results from historical traditions consisting in positive attitude of population towards federal and denominational activities. Professional fire fighters act mainly in large cities in both countries. The already mentioned organisation THW in Germany acts on the basis of volunteers (except for a necessary number of managers). It fulfils a function of nationwide second-plan resources and is engaged in case of vast natural and anthropogenic disasters even abroad.

In Scandinavian states especially in Finland and Sweden rescue services (fire fighters have no legal subjectivity, but they are a segment of rescue service) are mostly based on a *professional* basis. These services cover a wide range of tasks, especially in the cities. Voluntary health rescue services support rescue services mainly in the country where rescue services consist mostly of part-time workers or volunteers (especially in Finland).

Some units are replenished by staff on the basis of civil or substitute service. These units are mainly the THW units in Germany, auxiliary services in Austria and rescue services in Sweden. Their number is low (several thousand of persons).

Each of the mentioned models has its advantages and disadvantages. Militia system in such a large extent as practised in Switzerland requires education and training of persons subject to compulsory service and it also requires off-budget costs. A professional model guarantees a certain standard on professional level; however, it requires extensive budget costs. Certain optimum seems to be a combination of all three models of service respecting specific conditions and cultural-historical traditions of a given state.

In some countries (e.g. France), there is an effort to increase the portion of professionals, especially with fire fighters like in Scandinavian countries; in other countries (Austria, Germany) principle of voluntarism has been still maintained.

Education and Training

Education process including practical training and joint exercises of individual rescue units of protection of population depends primarily on the model of the service and also on the character and specificity of each rescue entity.

In case when the model is based on compulsory service (militia system), which is most extensively used only in Switzerland and in a limited extent in France, and Sweden, great demands are posed upon educational and training facilities. Education and training of e.g. 160 thousand fire fighters within the canton compulsory

service and 300 thousand members of civil protection organisations within the national compulsory service in Switzerland require a great number of educational facilities (roughly one in each canton), lecturers, auxiliary staff, and budget finances.

A professional model with regard to a limited number of professional rescue entities poses claims primarily on a high level of educational facilities, professional quality of lecturers, material and technical equipment, and training premises.

Volunteers in rescue entities are mostly prepared for their service on the lowest administrative and self-government level (besides nucleus of commanders) within their related organisation.

Basic education of fire fighters is performed mostly in communities (Switzerland, Germany) and departments (France). Further special education and education of nucleus of commanders is performed on canton level (Switzerland), federal lands (Germany, Austria) or in the central educational facility (France). In countries where fire fighters make a segment of so-called rescue service (Finland, Sweden), education is provided in central educational facilities on state level.

Members of health rescue service and police are prepared for tasks in protection of population mostly in their own government department facilities within their professional training.

Auxiliary services and other organisations of various legal nature providing assistance to the first-plan units (primarily in the German-speaking countries) are mostly trained in their own facilities; Their nucleus of commanders also takes part in training in central facilities on state level.

Second-plan units designed for engagement in disasters and emergencies (UIISC in France, THW in Germany, National Rescue Corps in Denmark) are trained in central educational facilities on state level. A certain exception represents the THW in Germany with cc 70 thousand members educated and trained at the level of community and managers educated and trained at the level of a federal state.

Units of armed forces intended to provide subsidiary assistance, mostly in the countries where the second-plan resources of engagement do not exist. In this case the country does not perform any special education and training within the area of protection of population.

Most countries tend to perform educational processes jointly with the aim at optimisation in the engagement itself. There is a trend asserted to perform the basic and further education of the members of rescue units *centrally in one or few* educational facilities.

Protective Infrastructure (protection provided by shelters)

Essential part of protection of population is so-called protective infrastructure comprising shelters for population, protected facili-

ties (health facilities, communication equipment, warehouses) and protective constructions (command posts, dispatcher posts, etc.).

Building of protective infrastructure is a long-term process, finances-intensive and it is closely connected with the concepts of population protection as a whole. Protection of population in shelters has served almost exclusively in case of an armed conflict, which can theoretically arise in a relatively short period of time. If the shelters are in good technical conditions and in full operating conditions, usual time to get them ready for operation takes cc 24 hours. From these reasons as well as the reasons of dislocation, these shelters cannot be used immediately for protection of population in natural and anthropogenic disasters or in case of an unexpected terrorist attack.

Long-term attention was paid to the problems related to building of protective infrastructure mainly in Switzerland, Scandinavian countries, and Israel where percentage of protection of population in shelters in comparison with the number of population is very high. Protective infrastructure has been built in these countries after World War II for more than 50 years and necessary legislation conditions have been created for these activities. The basis of them comprised individual acts specifying building of shelters in defined kinds of structures, as e.g. Federal act on building measures in civil protection of 1963 as amended (Switzerland).

The level of shelters provided for protection of population in relation to the number of inhabitants varies in different countries. Though different standards for shelter division into categories are applied especially from the pressure resistance at the front of a overpressure wave and equipment availability point of view, certain comparisons can be made. The highest level shows Switzerland - 95-100 % (in relation to the number of inhabitants, however it shows local gaps and "exceeds") and Sweden - approximately 80 %. Next is Finland - approximately 50 % (70 % in the south, 40 % in the north) and Austria - approximately 30 % (great differences are among individual federal lands - Styria 70 %, Vienna 3 %, and great differences are in equipment and usability). On the other hand, Germany shows shelters only for 3 % of inhabitants (after World War II no shelters have been built) and in France where no shelters for the population are available. The existing fund of shelters has merely been maintained in all European countries, only in Finland building of shelters has been continuing with the aim to provide protection in fixed, pressure-resistant shelters for as much people as possible.

Most of already built or currently built public shelters are shelters built from public finances and they are called double-use structures because of being used as hostels, garages, etc. in peacetime and serving to its original purpose - protection of population after getting to operating conditions.

Co-operation with Armed Forces

Armed forces provide subsidiary support during disasters and emergencies in all countries. Switzerland Armed Forces dispose

of a department for assistance during disasters (cc 2.4 thousand members) and rescue units (cc 23 thousand members) divided into groups specialised for these purposes. Other countries also have groups within armed forces, which can be engaged in assistance both inside and outside the state. These groups usually dispose of heavy mechanisms, instruments and transport means. The principle that armed forces are asked for assistance if the civil resources are insufficient to cope with the event is applied in all countries. Corresponding conditions or deadlines are not defined by any key decrees. The most significant support of armed forces is provided in France where, together with special military units of the Ministry of Interior (UIISC), groups for assistance during disasters are available permanently. In Austria, armed forces may be asked anytime for intervention by relevant political bodies. In Germany, armed forces are used mainly in the field of health rescue service.

Assistance from the part of armed forces is mostly preceded by respective planning activity at all levels of state administration and self-government. This assistance has a decisive meaning for the states lacking nation-wide (second-plan) forces and means to cope with disasters and emergencies. Optimal co-operation between civil and military sphere is in the countries where ministry of defence is a warrantor responsible for co-ordination and control of civil emergency planning (Sweden, Switzerland). This is expressed under "normal" situation mostly in a joint planning activity for emergencies, usually based on the co-ordination contracts, and in performance of joint training and practical co-ordination exercises.

International Co-operation

Actions abroad within international assistance in disasters and humanitarian aid play more important role in most countries. Principally this means the second-plan resources of engagement and a lot of countries have been establishing special units for these purposes (SEBA within the THW - Germany, FINNENRESCUE-FORCE - Finland, etc.). Logistic support of these units makes possible to transport these units including their material and equipment to any place of engagement.

2. Research Support of Population Protection in the Czech Republic

Research and development in advanced democratic states are being evaluated as a decisive factor of the society level, and a decisive factor of its further progress. The base for the successful orientation of individual areas of science and research are working systems of management, especially their rational supreme bodies and institutions for scientific and information support. Current development in the field of science and research is impossible without versatile co-operation and integration.

In December 2003 the European Union Council Resolution on strengthening community cooperation in the field of civil protection research was adopted (2003/C 8/2).

Consequently in 2004 the European Union established preliminary research program in the security field for years 2004 - 2006 including population protection against CBRN issues, emergency management and warning of population.

As well as the NATO opens Program for Security through Research. Prior areas are: CBRN detection, population protection against CBRN, decontamination and protection of critical infrastructure sections.

Current and long-term research program in the Czech Republic is complying with the above stated matters and is being preferably oriented to strategic ways including especially:

- warning of population
- analysis, detection and decontamination of highly toxic substances including CBRN
- emergency management
- personal means of population protection
- communication and information systems

In the area of timely warning of population the research is aimed at a multidiscipline approach of task solving and integration of the outputs with other expertnesses such as emergency management, protection of population, informatics, and communication. The products after further elaboration will be used in an education process for preparation of emergency management, users of a unified system of warning, and a groundwork for concept materials, materials for decision making support of leaders etc.

In the area of analysis, detection and decontamination of highly toxic substances the development of chemical research and laboratory verification is being insured. The activities encompass the development of methodology and means of detection, characterization, identification and determination of highly toxic substances including CBRN issues in case of their rampant leakage into the environment as a result of a breakdown or a terrorist misuse, and interpretation of measured data oriented to mitigation or elimination of leakage consequences for population.

In the area of emergency management it appears indispensable to create conditions for a coordination and controlling role of an emergency control by means of practical tools of an emergency manager in the stage of the preparation for an emergency, in the stage of still manageable emergencies, in the stage of coping with emergencies, and finally in the phase of liquidation of consequences and sanitation works. This presupposes especially further research of methodology of risk analyses for emergency preparedness in the frame of planning of emergencies and crisis situations on the territory. In further research it is necessary to continue on elaboration of methodology designed for mastering of decision making processes in crisis staffs with the support of information and communication technologies. Attention to the role of working with the public on all levels of control is also paid.

In the area of personal means of population protection it will be necessary to develop the testing of personal protective equipment

(PPE). The aim is, on the base of acquired results of PPE testing, to suggest measures for lengthening of their operation lives. Attention is also paid to the issue of improvised shelters that should fill up the current shelter fund in the Czech Republic.

In the area of communication and information systems it is necessary to create adequate conditions for the development and realization of these systems as an efficient support in connection with operation processes, linked with the preparation for solving, and final solving of emergencies and crisis situations. In this context it means control processes imminently touching all central administration authorities, other administration bodies, self-administration bodies, and in the final eventuality all citizens of the Czech Republic. Information and communication systems for the support of emergency control have to therefore, among others, make possible to hold independent communication channels by means of reserve nets during the crisis, manage the course of crisis situations from different places including air means, use up-to-date relevant data

wherever accepted, whenever, and in whatever way and manage the course of a crisis situation or currently proceeding emergencies in a group and not only individually. In the frame of these systems the emphasis will be placed on the mutual interconnection of function sections strengthening especially an up-to-date integrated picture of the situation, a tool for evaluation of the magnitude of the situation, visualization of information, operation planning. Further the emphasis will be placed on the possibility of command and control of intervention units and monitoring of their activities in the terrain, shortening of the time necessary for the performance of orders and control directions, tools for debriefings and realization of training.

In conclusion it is possible to claim that on the base of new threats appearing lately, especially terrorism, the research activity in the area of population protection and emergency management becomes utterly indispensable and not substitutable.

References

- [1] *Security of Cooperation (in German)*, The report of federal council on safety policy of Switzerland from 7. June 1999 proposed at federal congress, Bern 1999.
- [2] *Swiss General Risk-Analysis (in German)*, Bern 1999.
- [3] *Common Security and the Future of the Army (in German)*, The report of Weizsäcker's committee for federal government, 2000.
- [4] *International CEP Handbook 2003: Civil Emergency Planning in the NATO/EAPC Countries*, SEMA, Stockholm 2003.
- [5] *Defense and Civil Security – Everybody's Affair (in French)*, The booklet of civil safety directorate, Paris 2000.
- [6] *Robustness in the Physical Environment*, The Swedish Agency for Civil Emergency Planning and the Swedish Board of Housing, Building and Planning in co-operation with the Swedish Rescue Services Agency and the Swedish Environmental Protection Board, Stockholm 1999.
- [7] *Main Idea of Population Protection (in German)*, Government report for the parliament on the population protection conception), Bern 2001.
- [8] *International Directory 2001 – Civil Protection, Civil Defence, Civil Safety, Emergency Management*, International Civil Defence Organization (ICDO), Geneva 2001.
- [9] *Procedural methods for the support of decision making in favor of crisis management the project of defensive research under the code PROCES*, Research project, ICO ČR, Lázně Bohdaneč 1999.
- [10] *The conception of population protection until 2006 with prospects till 2015*, MV-GŘ HZS ČR, Praha 2003.

Ján Slosiarik *

TESTING OF THE FLAME SPREAD LINEAR SPEED ON FOODSTUFFS AND AGRICULTURE DUST LAYERS

The paper deals with results of linear speed tests on foodstuffs and agriculture dust layers. The experiments were performed with different samples, focusing on flame spread on the dusts layers occurred in agriculture and food industry.

Introduction

Nowadays there is an absence of experimental knowledge in the field of organic dust combustion and this status requires to quantify in a detailed way particular conditions of the initiation as well as propagation of the burning process of these materials.

This paper aims to contribute to the extension of the burning process measurement problems in the case of sedentary organic dusts. Research up to now has dealt with dust problems on a lignocellulose materials basis. Subject research focused on the linear speed monitoring of the flame spread on sedentary dusts layers occurred in agriculture and food industry, depending on the conditions as thickness, sedentary layer moisture and area tilt, where the dust is sedentary.

Test results should contribute to:

- the development of such testing methods, which monitor sedentary dusts burning propagation,
- the knowledge acquisition, dealing with the linear speed of sedentary organic dusts burning depending on exterior conditions

Applied testing method

The measuring method is based on dust property to ignite after the initiation of a sufficiently intensive source and on the property of the flame transfer to further layers of sedentary dust. To make the measurement easy and fast, the whole measurement process is carried out in the oxygen atmosphere. Measured values are for this reason relative and they are not identical with the flame-spread speed in the air. [2] Burning process in practice in the absolute oxygen atmosphere may occur in technologies having their own oxygen distributions or in technologies working with pressure vessels, containing pure oxygen. During the measurement when the flame is transmitted from the sample surface to the indicated distance time is measured and from these values the flame-spread speed is calculated. The measurement is performed at the RO test apparatus (test of the oxidation speed). [1, 2]

RO apparatus description

The main component part of the RO apparatus is a tube made of chemical glass, with the inside diameter of 22 mm and a length of 200 mm, fastened to a metal holder situated in the apparatus upper board. The tube is connected to the steel pressure vessel with oxygen by the air pressure reducing valve and the rub hose strengthened by textile fibre. The quantity of incoming oxygen for the measurement is set by a regulator of the gas flow. A sample of measured dust is inserted into the open tube ending formed in the shape of standard bar form. A metal mat is indicated by notches of 100-mm distance between each other, limiting intended length of the formation supposed for measurement. The forms create formations of the height of 3.5 mm and 7 mm, length of 120 mm, the base width is 10 mm. The burning zone width is 12.2 mm at a 3 mm-dust layer thickness, as for 5-mm dust layer thickness there is 15.7 mm and for a dust layer of 13.1 mm thickness it is 7 mm. For the period measurement necessary for the flame spread along the length of the formation, the hand stopwatch is utilized. Sample ignition is performed at the operating path with the length of 15 mm by standard safety matches (STN EN 1783:1997: SAF).

Apparatus parametres:

Pressure of O₂ 20 – 50 MPa, pressure in the testing tube is identical with the surrounding atmospheric pressure. The extent of volume flow is 0 – 1 l.min⁻¹. [1, 2, 4]

Operating procedure

Before the beginning of measurement the oxygen pressure vessel is opened and the constant volume oxygen overflow through the tube is set by air pressure reducing valve at 0.175 l.min⁻¹. The measured sample is prepared in the shape of formation, to a metallic pad by a dust tumble from the bar. The formation is prepared in such a way that the dust is given into the bar and the redundant dust sample is removed by a metallic plate in the angle of 45°.

* Ján Slosiarik

Technical University in Zvolen, Faculty of Wood Sciences and Technology, Department of Fire Protection, Masaryka 24, SK-960 53 Zvolen, E-mail: slos@vsld.tuzvo.sk

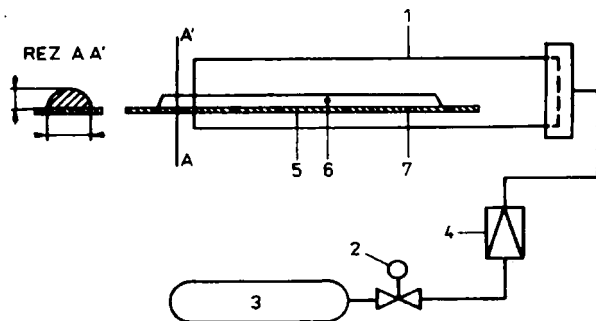

Fig. 1 Scheme of the equipment for oxidation speed determination (RO test)

(1 - combustion tube, 2 - air pressure reducing valve, 3 - pressure vessel for oxygen, 4 - flow measurement device, 5 - metallic pad, 6 - dust sample, 7 - notches)

Dust compression does not appear in this way and after the dump to the metallic pad the formation with smooth surface is created. The total length of formation is 120 mm. The measured sample is located at the metallic pad in such a way that one side of the formation would be exactly at one scratch, another scratch then exceeds the formation by 15 mm. An exceeding part of the formation serves for the sample ignition. The stop-watch is switched on when the flame is going to spread after the ignition, to the level of the chemical glass edge. Necessary time for the flame spread on the sample surface is measured by the stop-watch, in the oxygen countercurrent alongside the formation length of 100 mm [1, 2, 3] The test samples were tested at the horizontal position and at 35° inclination as well.

Measurement results processing and tasks evaluation

The final measurement value is an average time interval given in seconds, during which the flame is spread on the dust layers, alongside the length of 100 mm. Measurements for the given dust sample and given oxygen overflow in the combustion tube are performed five times and from the obtained measurements the average value of linear spread flame speed is calculated for the sample of flammable dust layer in the oxygen atmosphere according to the reference (2): [1, 2, 3]

$$W_0 = \frac{l}{\tau} \quad [\text{m}\cdot\text{s}^{-1}] \quad (1)$$

W_0 - spread flame speed (oxidation speed) on the dust layer

l - dust layer length in the defined intersection [m]

τ - time of the flame transfer alongside the layer length l [s]

Result evaluation

Nowadays there is no hazard classification system for industrial dusts, besides coal dusts, where the methodology of 3 danger classes has been accepted. For the dust classification previous system has been applied as for [3,4], extended by further class IV. according to Table. 1.

Classes of the flame spread danger on the surface of sedentary industrial dusts, based on the oxidation speed test Tab. 1

Danger Class	Dust Fire Characteristics	Oxidation Speed (RO) [s]
I.	Dust spreads the fire very well	RO ≤ 10 s
II.	Dust spreads the fire	10 s < RO ≤ 20 s
III.	Dust spreads with difficulties	20 s < RO
IV.	Dust does not spread the fire	RO = 0 s

Indication of moisture influence on linear flame spread speed in the atmosphere of pure oxygen, taking into consideration the thickness of sedentary dust and cocoa dust sample tilt, dried milk, foodstuff, flour and wheat grouts.

Experimental tests have been carried out by the method known as "RO test" for the flame burning propagation in the atmosphere of pure oxygen at the dynamic counter current flow of $0.175 \text{ l}\cdot\text{min}^{-1}$, which represented the speed of air circulation in the tube of $0.85 \text{ cm}\cdot\text{s}^{-1}$. For an experiment the following samples were utilized:

- cocoa of 0 % moisture and technological moisture of 8 %,
- dried milk of 0 % moisture and technological moisture of 4 %,
- foodstuff compound of 0 % moisture and technological moisture of 10 %,
- flour of 0 % moisture and technological moisture of 14 % and
- wheat grouts of 0 % moisture and technological moisture of 16 %.

Three thicknesses of sedentary cocoa dust, dried milk, foodstuff compound, flour and wheat grouts were observed (3 mm, 5 mm, 7 mm).

Besides the measurement of particular dust samples at different moistures and layer heights in the horizontal position, measurement was carried out also at the 35° slant. The tube with a sample was sloping in such a way that its opening for dust samples was in the downward direction. Tube slant of 35° ("shoot angle") was indicated in such a way that the position during which the sample stayed in the tube was found out.

The complete comparison of the horizontal position of 35°-sample slant (at the technological moisture of 0 % moisture) is given in Tables 2 and 3.

Conclusion

The measured data for researched samples confirmed theoretical assumptions about the influence of outside conditions, i.e. dust moisture, layer height, and dust sample slant on the result values. Identified dependencies:

Dust moisture - the measured samples were of 4 to 16 % of technological moisture. The results measured at the technological moisture were compared with the results measured at 0 % moisture. With the increasing moisture a burning time prolongation for all samples was noticed. The flour sample proved the value, which

Comparison of the horizontal position of 35 % sample slant at the technological moisture

Tab. 2

Sample name	Thickness of sedentary dust						Moisture [%]
	3 mm		5 mm		7 mm		
	Burning time [s]	Burning speed [cm.s ⁻¹]	Burning time [s]	Burning speed [cm.s ⁻¹]	Burning time [s]	Burning speed [cm.s ⁻¹]	
Sample in the horizontal position							
cocoa	4.68	2.15	3.26	3.10	2.37	4.30	8 %
dried milk	7.68	1.30	6.97	1.44	4.33	2.31	4 %
foodstuff	9.56	1.09	8.50	1.18	2.77	3.67	10 %
flour	14.69	0.68	13.08	0.76	10.64	0.94	14 %
wheat grouts	8.93	1.12	8.28	1.21	5.28	1.92	16 %
Sample of 35° slant							
cocoa	4.81	2.08	4.97	2.02	3.65	2.76	8 %
dried milk	7.43	1.35	7.46	1.34	4.28	2.35	4 %
foodstuff	12.18	0.84	6.86	1.48	3.47	2.89	10 %
flour	17.25	0.58	16.15	0.62	10.38	0.97	14 %
wheat grouts	10.87	0.92	10.19	0.98	6.64	1.51	16 %

Comment: All figures are given in the arithmetic mean

ranked it to the lower class of danger (from the first danger class to the second danger class)

Layer thickness - the measurements were performed for the layers thicknesses of 3 mm, 5 mm and 7 mm. The layer thickness increase represented the oxidation speed increase, with one exception. Anomaly appeared only in the sample of cocoa dust of 0 % moisture, where the oxidation speed decrease appeared at the 5 mm layer height compared with the oxidation speed for the dust sample of 3 mm height. This anomaly could be caused, for example, by a sample contamination, etc. (samples were checked just only by a riddle analysis, not by a chemical one).

References

[1] DAMEC, J., CHOLEVA, L.: *Laboratory practice of the counterexplosion of technological processes prevention*, IX. správa FMV, Praha VŠB 1980, p. 71
 [2] DAMEC, J., FONIOK, R., HANUŠ, A.: *Counterexplosion prevention*, Návod na cvičení, Vysoká škola báňská v Ostravě, Ostrava 1993, p. 7-10. ISBN 80-7078-191-2
 [3] DUNAJSKÝ, M.: *Linear speed of the flame spread on sedentary wood dusts*, Diploma thesis, TU Zvolen, 2003, p. 83
 [4] SLOSIARIK, J.: *Burning of sedentary flammable dust on the basis of lignocellulose materials*, Dizertačná práca, TU Zvolen, Zvolen 2002, p. 103
 [5] ŠAŠKOVÁ, V.: *Linear speed of the flame spread on the sedentary organic dusts layer*, In: Diploma thesis, TU Zvolen, 2004, pp. 47-60
 [6] MRAČKOVÁ, E.: *Monitoring of wheat dusts dimensions by laser analyser due to the explosion*, In: Zborník referátov z internetového diskusného fóra. Fórum mladých odborníkov požiarnej ochrany, 3. medzinárodný odborný seminár, KPO, TU Zvolen 2003, pp. 58-64, ISBN 80-228-1246-3

Comparison of the horizontal position of 35° sample slant at 0 % moisture

Tab. 3

Sample name	Thickness of sedentary dust						Moisture [%]
	3 mm		5 mm		7 mm		
	Burning time [s]	Burning speed [cm.s ⁻¹]	Burning time [s]	Burning speed [cm.s ⁻¹]	Burning time [s]	Burning speed [cm.s ⁻¹]	
Sample in the horizontal position							
cocoa	3.06	3.34	3.19	3.16	1.83	5.72	0 %
dried milk	3.97	2.53	3.83	2.63	2.29	4.41	0 %
foodstuff	4.59	2.18	2.70	3.81	1.66	6.10	0 %
flour	4.34	2.31	3.87	2.59	2.88	3.53	0 %
wheat grouts	2.74	3.65	2.59	3.86	1.53	6.67	0 %
Sample of 35° slant							
cocoa	4.08	2.46	3.45	2.91	2.73	3.67	0 %
dried milk	4.11	2.43	5.00	2.00	2.10	4.78	0 %
foodstuff	5.26	1.91	3.77	2.71	1.78	5.65	0 %
flour	4.89	2.05	4.08	2.45	3.21	3.12	0 %
wheat grouts	3.01	3.33	2.77	3.62	1.45	6.95	0 %

Comment: All figures are given in the arithmetic mean

Sample slant - the measurement was performed at the horizontal position and at a 35° slant. From the measured values we can assume that during the measurements there was not always a chimney effect phenomenon, on the contrary, oxidation speed was sometimes decreased probably by bad combustion products. The inlet hose for oxygen was integrated at the upper ending of the tube and because of the fact that the combustions are moving in upward direction, deceleration of the oxygen feeding to the burning zone appeared. Generally the influence of the layer tilt on the oxidation speed was confirmed [5, 6].

Juraj Sluka – Zdeněk Dvořák – Lenka Rošteková *

THE POSSIBILITY OF USING THE GEOGRAPHICAL INFORMATION SYSTEMS IN THE PIPE TRANSPORT OF THE ARMED FORCES OF SLOVAKIA

The paper describes possibilities of the geographical information systems' usage in the pipe transport. All parts of information systems including hardware, software, peopleware, dataware and orgware are in a continuous process of development. Advantages and disadvantages of GISs are their important part. Pipe transport is part of transport provision in Slovakia. The Armed Forces of the Slovak Republic are preparing universal units for usage throughout the whole world. The pipe transport supported by a GIS is able to move different liquids into all crises places.

1. Introduction

Contemporary information systems oriented towards management support of all people's activities are based on databases systems and transformed to geographical systems. The Armed Forces of the Slovak Republic have planned creation of several information systems. One of them uses geographical systems for pipe transport.

2. Possibility of geographical information systems' creation

The Geographical Information System (GIS) is the most dynamically developing system from all existing information systems. It is because of the crucial role of object and phenomenon localization, which are processed by this system. There has been observed an increase of the usage of Geographical Information Systems in private and public sectors. Concerning development of GISs, there were various problems to deal with in the past. Hardware and software were too expensive, graphic data were expensive as well and it was difficult to get them. At the same time knowledge of the users of a GIS had to be above-standard. Nevertheless, rapid development of technologies has caused that GISs are becoming more acceptable.

There are various forms of GISs. These systems differ according to their time and financial demands. As to information systems, requirements of every organization differ. The reasons are various kinds of data processing, present condition and quality of used data, and different technological equipment.

One of the main objectives of transport logistics is development of such systems and subsystems, which would command and control transport logistics compatible with NATO countries.

Development of a modern GIS is a common objective of the Armed Forces of the Slovak Republic (AF SR) and NATO. This system should comply with the latest requirements for data-processing, as well as for transmission and interpretation of results. The start of GIS's operation is supported by development of software, hardware and the Internet.

Military transport authorities have always used communication systems. Military transport controllers are considered to be basic elements in data processing. Telephones, teleprinters and faxes are their main means of communication. Development of computer technology allows the use of personal computers for processing and transmission of information.

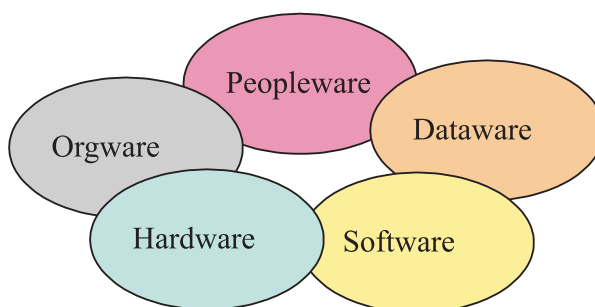

Fig. 1. Basic parts of an information system.

2.1 Information system should comprise two levels

1. Collection of information, development of information databases and processing of documents, necessary for the increase of managerial activities' effectiveness;

* Juraj Sluka¹, Zdeněk Dvořák², Lenka Rošteková²

¹Armed Forces of the Slovak Republic, Zemianské Kostolány, E-mail: Sluka@pobox.sk

²Department of Technical Sciences and Informatics, Faculty of Special Engineering, University of Žilina, E-mail: Zdenek.Dvorak@fsi.utc.sk, Lenka.Rostekova@fsi.utc.sk, phone: ++421 41 513 6854, 513 6859

2. Process of collection and activation of information and information documents necessary for performance of information services (automatic information forwarding to users).

All geographical information systems of the military transport should be divided and linked vertically and horizontally. Vertically in the system of providing defense of the Slovak Republic starting from Security Council of Slovakia, through territorial authorities of the military transport, to the executive authorities of military transport. At a horizontal level linking with military authorities within the framework of territory, public administration authorities, authorities of the Railways of the Slovak Republic, and transport companies is necessary.

2.2 Advantages of GIS application in military transport:

- digital principle of activity,
- transfer of real-time information,
- high degree of safety of transferred information,
- high quality of processed data,
- compatibility of individual subsystems (mutual and with NATO countries),
- increase of speed and quality of monitoring,
- increase of speed and quality of operative control,
- decrease of human failure coefficient,
- availability and variety of real-time information,
- possibility of database upgrading,
- low operating costs (capacity/effectiveness ratio).

2.3 Disadvantages of GIS:

- high expenses for development of the system,
- lack of experts in the Armed Forces of the Slovak Republic,
- lack of software and hardware equipment in the Armed Forces of the Slovak Republic,
- high requirements for the level of protection of technical equipment, program equipment and data structure of an information system.

3. Basic parts of a GIS in military transport

3.1 Preparation and creation of a project for concrete application

According to tasks and aims, which a GIS has to solve, there are specified individual points of a project:

- requirements of clients,
- costs,
- GIS safety level,
- data preparation, processing and transfer rate,
- operating costs (software, hardware...),
- analyses and interpretation of results,
- outputs (graphic description),
- usage of original subsystems (to minimize expenses).

3.2 Databases

Data processing by individual authorities of the military transport has existed since the computers started to be used. Differences between the inner structure of data cause that we cannot use the same databases in various thematic models of a GIS. Their usage depends either on partial adjustments, or on new databases structures' development.

In the conditions of military transport we can use these already existing databases:

- databases of infrastructure (technical parameters of selected road and railway networks, parameters of pipelines ...),
- databases of technical means and means of transport (capacity, fuel consumption, tactical-technical data ...).

The usage of individual databases depends on a concrete GIS and on the inner structure of data.

3.3 Software systems

The choice of software depends on requirements of a user (a client). Nowadays we have a sufficient amount of various GISs. Everything depends on hardware capacity, speed of data preparation, data-processing and on the speed of data transfer. The choice of a system is also influenced by an output device in the area of military transport. The choice of an information system is influenced mainly by the kind of transport.

3.4 Analysis and interpretation of graphic information selection

Graphic information can include:

- Automobile transport (effective usage of vehicles, their consumption, statistics of route's length, monitoring of vehicles' movement in a real time, choice of the shortest route ...),
- Railway transport (real time train set movement monitoring, real time shipping capacity, usage of carriages, consumption of electric energy or other kinds of fuel),
- Pipe transport (monitoring of transported product's leakage, amount of transported products, and capacity of pumping equipment ...),
- Air transport (statistics of hours flown, fuel consumption, real time airplane movement monitoring ...).

3.5 Outputs

A choice of outputs is offered during the work with a GIS. The outputs depend on specific requirements of their user, his economic potential and actual usage of a GIS (in terrain, in transport means), stationary equipment, and selected level of security.

Final outputs will use maximum number of the best quality data in minimum time. This is restricted by technical and software parameters of a specific GIS.

4. Position and importance of pipe transport in the Armed Forces of the Slovak Republic

Pipe transport has been mostly used as a technological transport. It has gradually developed and formed its characteristic features.

Pipe transport is used mainly for:

- long distance transport of fuel, usually between state pipelines and warehouses,
- building of pipelines in the area of damaged railway lines,
- ground or air forces supply.

Fuel pipe transport units can be used in the state of crisis in the Slovak Republic or abroad, within the framework of UN units, in these cases:

- fulfillment of transport tasks within the framework of UN units,
- minimization of accident consequences,
- assistance in reconstruction and modernization of present elements of infrastructure,
- evacuation of oil stock in case of an ecological disaster,
- transport of huge volume of water to extinguish a fire or to provide water regime in areas, which suffer of extreme drought,
- drawing off of huge volumes of water from important flooded objects.

In the past managerial activities of the pipe transport resulted mainly from previous practices based on headquarters' experience, as well as on maps, graphical and textual enclosures. Nowadays there is a possibility to prepare a functioning GIS, which should contain:

- provision of a continuous preparation of units and material for the fulfillment of tasks connected with building, operation and rolling up of field pipelines (FP),
- tasks setting for units, which build, operate and roll up FP,
- organization of cooperation,
- uninterrupted connection with units, operating and technical elements of FP,
- maneuvers with forces, technical means and material,
- control of units which build, operate and roll up PDP,
- organization of accidents and problems' removal on PDP,
- protection and defense of an organization.



Fig. 2. Military pipeline equipment.

These are general stages of managerial activities in pipe transport:

1. Planning
2. Building of PDP
3. Operating of PDP
4. Rolling up PDP

5. Possibilities of a GIS usage in the pipe transport within the framework of the Armed Forces of the Slovak Republic

GIS usage in the pipe transport seems to be an advantageous way to improve transport and supply systems in the Armed Forces of the Slovak Republic. The civil sector uses a GIS for a pipeline operation in the Slovak Republic. Because activities of the pipe transport units are narrowly linked with pipelines' operation, there is a real possibility to use the civil sector GIS experience and to prepare a similar GIS for the usage within the framework of the Armed Forces of the Slovak Republic. An application of such a GIS in the Armed Forces of the Slovak Republic would be more difficult from the point of view of operation and reliability during the compulsory state alert. We should think about a kind of a Mobile GIS model. Its main task would be to offer responsible stereoscopic information in the right place, in actual time and using minimum costs.

5.1 Advantages of a GIS's application in the pipe transport:

- decrease of operating costs (lower costs for external services, higher effectiveness of maintenance),
- planning of costs for a specific combat mission,
- prevention of breakdowns (better prevention of breakdowns and better evaluation of pipelines' renewal),
- quick and latest information about pipeline technology and its surroundings in the case of a breakdown,
- analytical information (analyses of space, analyses of medium leakage into terrain ...),
- digital principle of its activities,
- transfer of information in actual time,
- high degree of safety of transferred information,
- high quality of processed data,
- mutual compatibility of individual subsystems, and their compatibility with NATO,
- increase of speed and quality of monitoring,
- increase of speed and quality of operative control,
- decrease of a human failure coefficient,
- availability and variety of real-time information,
- possibility of database updating,
- possibility for the usage of the pipe units abroad (usage of a digital model of a country).

5.2 Disadvantages of a GIS in the pipe transport:

- high expenses for the system's setting up,

- lack of experts in the Armed Forces of the Slovak Republic,
- lack of software and hardware equipment in the Armed Forces of the Slovak Republic,
- high expenses for installation of pumping units monitoring equipment,
- high requirements for the level of protection of technical equipment, program equipment and information system data structure.

A high quality GIS preparation for pipeline units' activities makes managerial activities easier. It will provide the fulfillment of combat missions with NATO units, wherever all over the world.

Information systems are one of the basic problems solved within the framework of transformation of the Armed Forces of the

Slovak Republic. Proposed and prepared solutions put emphasis on a linkage of information systems with managerial activities connected with the State Information System. This brings improvement to managerial activities in all spheres.

Conclusion

An implementation of new and modern software in military corps is one of the main future tasks. Our managerial staff is very well prepared for all managerial activities. Currently, there is a great possibility to create new information systems based on Geographical Information Systems.

References

- [1] DVOŘÁK, Z. et al.: *Technology and Services of Intelligent Transport in Conditions of the Slovak Republic*, ŽU v Žiline, 2005, pp. 83-97.
- [2] SEIDL, M., TOMEK, M.: *The Usage of Pipe Transport in Crises Situations*, ŽU v Žiline, ISBN 80-8070-187-3, 2004, pp. 24 and 33
- [3] SLUKA, J., DVOŘÁK, Z., KAŠPAR, V.: *Geographical Information Systems and Pipe Transport*, In: Sborník - Krizový management v dopravě a státní správě, 2003, Pec pod Snežkou, ISBN 80-86530-10-8
- [4] ŠIMÁK, L. et al.: *Transport in Crises Situations*, ŽU v Žiline, 1999, ISBN 80-88829-53-4
- [5] TOMEK, M., LUSKOVÁ, M.: *Alternative Long Distance Pipeline and Crises Situations*, In: Sborník 4. konference s mezinárodní účastí Krizové stavy a doprava. Pardubice, Institut Jana Pernera, 2004, p. 149-153, ISBN 80-86530-20-5

I. Milata – L. Rošteková – V. Kašpar – Z. Dvořák *

MATHEMATICAL SUPPORT OF CRISIS PLANNING

It is impossible to eliminate the occurrence of crises and crises situations in society, nature and in production processes. That is why it is necessary to search for such paths and procedures, which would minimise the crises processes and consequences. Methods of mathematical statistics provide valuable information for crises planning in the sphere of mathematical forecasting.

Introduction

The existence of life on earth is linked with nature and the living environment, which people try to modify according to their needs. These activities are connected with a number of risks, which endanger not only the environment but also people themselves. Emergency situations and various crises events have accompanied and will accompany our lives forever. They are an inseparable part of our lives and people have to find ways how to prevent them and, in case they occur, how to eliminate their consequences and minimise losses and damages. In case we apply appropriate preparations and technological procedures, it is possible, to a certain extent, affect the occurrence and elimination of crises situations consequences.

People have to base their future on knowledge and understanding of the past. Society tries to predict and appropriately respond to the origin of crises situations using crisis planning and by creation of material, technical, technological and human resources. Identification of consequences and patterns of emergency situations and forecasting of their occurrence and consequences are the main prerequisite for their successful solution. Authorities and people interested in advance try to provide measurements, which make their early and effective control possible.

Crisis planning should offer and prepare measurements for solution of crises situations, which could occur sometime in the future. It follows the experience gained in the past and tries to prepare such plans and measurements that would prevent the origin of emergency situations or that would minimise their consequences. That is why forecasting is a very crucial task of crisis planning.

As people gradually reveal the nature of natural and social phenomena, they also create systems for monitoring of the risk factors involved. This enables to identify dependencies of phenomena such as natural disasters, calamities, catastrophes etc., and to predict their occurrence as well as to provide measurements for losses and damages minimisation. In certain cases this method has enabled to get natural elements under control with no damages. This is one of the objectives of the crisis management strategy.

From the point of view of purposes specified and means used we can define political, diplomatic, economical, safety, military and scientific-technical crisis management strategy.

There exists a universally acceptable principle. The means of prevention and solution of crises and crises events incurred are in due proportion to the knowledge and technical potential of the mankind. That is why elaboration and actual application of mathematical methods to crisis planning tasks is one of the objectives of current science. Contemporary mathematical statistics methods enable not only statistical bulk data processing, but also acquisition of a lot of information of high predicative capacity.

Mathematical Statistics

Mathematical statistics and statistic analysis methods are more and more used in various subject fields. Statistics is a theoretical branch of knowledge. It studies the state and development of numerically formulated bulk phenomena. These phenomena can occur in various spheres concerning people and their activities, animals, things, organisations, institutions, societies, as well as production, management, natural phenomena and others. Mathematical statistics does not only deal with quantitative part of bulk phenomena, but also with their qualitative part. Using statistical analysis, it can also reveal various regularities, dependencies and development tendencies of the set of elements. These revealed regularities as well as identified coherence in the state and development of phenomena are later used in application from parts to the whole, from partial to universal as well as in forecasting of bulk phenomena future development.

Forecasting by Means of Mathematical Statistics

Statistical set is a basis for any statistical enquiry. It comprises a sample of objects (elements, phenomena, actions, elements, measurements, etc.). There are two kinds of statistical sets: primary (contains all elements) and selected (contains only a certain subset of a primary set). The set range should be representative and as

* I. Milata, L. Rošteková, V. Kašpar, Z. Dvořák

Department of Technical Sciences and Informatics, Faculty of Special Engineering, University of Žilina, Slovakia, E-mail: milata@fsi.utc.sk

wide as possible to compensate incidental, irrelevant and accidental influences.

For statistical forecasting it is necessary to balance the examined set by such a curve that would bind to the elements of the set as much as possible. The function of this curve enables us to perform calculation of set indicators in other spheres than those measured beforehand or to perform mathematical forecasting.

Statistical research is divided into four basic consecutive parts:

1. Statistical detection or material collection. When collecting statistical data it is possible to use these basic methods:
 - Reports - information of news units
 - Measurements of real actions (monitoring)
 - Questionnaires filled in subjects.
2. Material classification - characteristics calculation.
3. Statistical analysis (in this case correlation and regression analysis)
4. Adoption of hypotheses and estimations, their testing.

Correlation is a statistical relation of two or more variables. It presents information on statistical relation of phenomena, determines the strength of this relation, but it does not inform on their cause. The main result of a correlation is called the correlation coefficient r or correlation index. Correlation coefficient r varies from 0 to 1. It indicates how expected (anticipated) values, expressed by perfect correlation line, match real data. A coefficient of 1 gives a perfect fit.

It is possible to use analytical method of correlation to test relationship of two data sets. Positive correlation is a relation in which the high values in one set match high values in the second set. Negative correlation means that low values in one set match high values in the second set. If there is no connection between values in both sets, we say there is zero correlation.

Correlation coefficient squared

$$r^2 = 1 - \frac{\sum_{i=1}^n (y_i - y(x))^2}{\sum_{i=1}^n (y_i - \langle y_i \rangle)^2} \tag{1}$$

Definitions x is x - coordinate of a data point
 y is y -- coordinate of a data point
 n is number of data points

$$\langle y_i \rangle = \frac{\sum_{i=1}^n y_i}{n} \tag{2}$$

- $r = 0.0 - 0.3$ means weak correlation
- $r = 0.3 - 0.7$ means moderate correlation
- $r = 0.7 - 0.9$ means strong correlation
- $r = 0.9 - 1.0$ means very strong correlation

Regression determines the shape of statistical relation.

Regression analysis is, by means of perfect regression line, used for graphic representation of orientation in data and for the study

of forecasting problems. By means of regression analysis, through extension of perfect regression line it is possible to determine values before and after displayed data. This way we can perform mathematical forecast. Accuracy of mathematical forecasting bears a proportion to the strength of correlation relation.

Methods of least squares are used to define coefficient of a regression function. This means that we are looking for such a function, where the difference between sums of squares of the offsets of measured and theoretical data is minimal. From the point of geometrical view it means that we are looking for such a curve that would fit the best to individual points. Function of this curve should be as easy as possible, so it can be easily used for calculation of other necessary values. There exist various shapes of regression lines.

Most frequently we use these functions:

- linear
- exponential
- power
- logarithmic
- polynomial

Linear Function Equation

The easiest equation of measured parameters is their equation by linear function. *Linear best-fit line* is a line used in simple linear data sets. Data is linear, when the course of data points resembles a line. Linear best-fit line usually graphs that something constantly rises or decreases.

$$y = a + bx \tag{3}$$

Calculation of a, b constants:

$$a = \frac{\sum_{i=1}^n x_i^2 \sum_{i=1}^n y_i - \sum_{i=1}^n x_i \sum_{i=1}^n x_i y_i}{n \sum_{i=1}^n x_i^2 - \left(\sum_{i=1}^n x_i\right)^2} \tag{4}$$

Example of Linear Equation

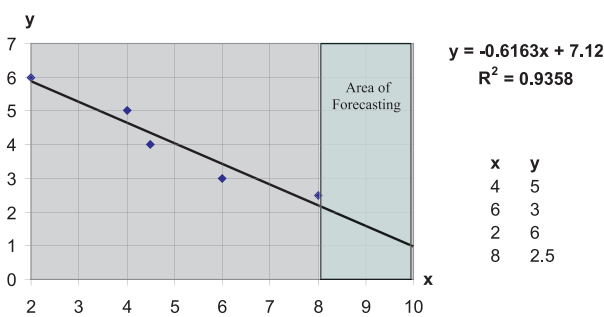

$$a = \frac{\sum_{i=1}^n x_i y_i - \sum_{i=1}^n x_i \sum_{i=1}^n y_i}{n \sum_{i=1}^n x_i^2 - \left(\sum_{i=1}^n x_i\right)^2} \quad (5)$$

Power Function Equation

Power best-fit line is a curve used in the case of data which compare rising values measured in specific intervals. E.g. car acceleration at intervals of 1sec. It is not possible to graph a power best-fit line when the data includes zero or negative values.

$$y = ax^b \quad (5)$$

Calculation of a, b constants:

$$\log a = \frac{n \sum_{i=1}^n x_i \log y_i - \sum_{i=1}^n x_i \sum_{i=1}^n \log y_i}{n \sum_{i=1}^n x_i^2 - \left(\sum_{i=1}^n x_i\right)^2} \quad (6)$$

$$\log b = \frac{n \sum_{i=1}^n x_i^2 \sum_{i=1}^n \log y_i - \sum_{i=1}^n x_i \sum_{i=1}^n x_i \log y_i}{n \sum_{i=1}^n x_i^2 - \left(\sum_{i=1}^n x_i\right)^2} \quad (7)$$

Example of Power Function Equation

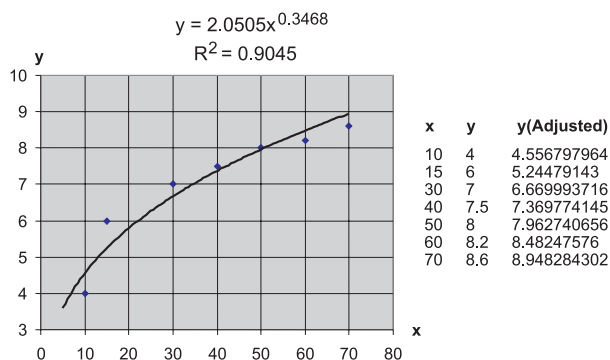

Logarithmic Function Equation

Logarithmic best-fit line is an adjusted curve used when data is quickly rising or decreasing and then continuously adjusting. It is possible to include positive and negative values when graphing logarithmic best-fit line.

$$y = a \ln(x) + b \quad (8)$$

Example of Logarithmic Function Equation

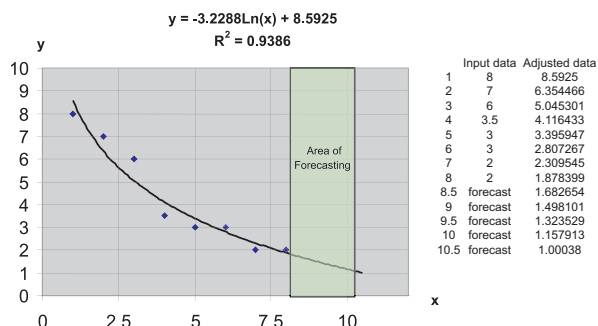

Polynomial Function Equation

Polynomial best-fit line is a curve used when data varies and it is not possible to approximate it by a simpler function. The degree of polynomial can be defined by a number of data variation or by a number of curvatures (maxima and minima) in a curve. Degree 2 usually has one local maximum. Degree 3 usually has one or two local maxima. Degree 4 usually has as many as three local maxima.

$$y = a + b_1x + b_2x^2 + \dots + b_nx^n \quad (9)$$

Degree 3 Polynomial Function Equation

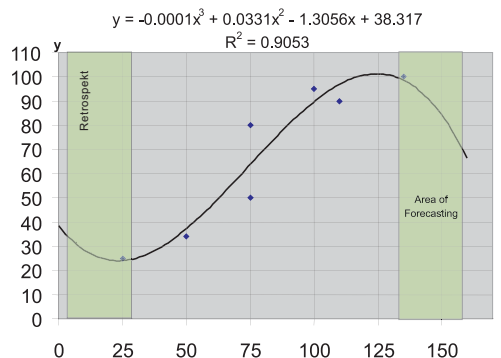

Exponential Function Equation

Exponential best-fit line is a curve, which is used in case when data values rise or decrease markedly. It is not possible to graph this line, when data includes zero or negative values.

$$y = ae^{bx} \quad (10)$$

This is a practical air transport example for exponential function equation.

This graph shows a statistical set containing real observed data. It presents the number of fatal accidents per 1 million kilometres

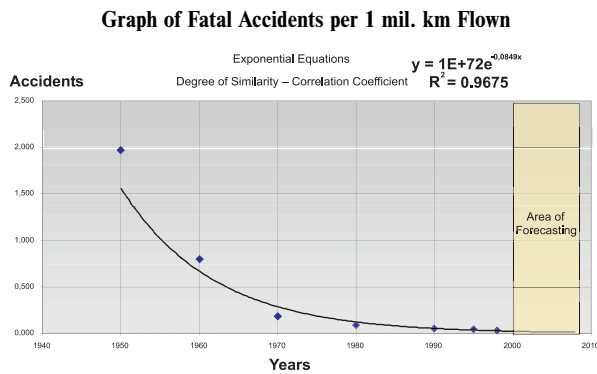

flown in the period of years 1950 – 1998. The set has been equated by exponential function. Correlation coefficient of 0.9682 is quite high, so it is possible to use exponential function for statistic forecasting. This has been realized numerically and graphically for the period of years 2004 – 2008. Larger number of real data indicates more accurate results.

Forecasted data is extremely valuable information necessary for crisis planning strategy. This and similarly evaluated real information can be applied to every airport. This enables to prepare appropriate size of local rescue forces and means, as well as to

References

[1] SOUŠEK, R.: *Crisis management of transport (in Czech)*, Institute of Jan Perner, o.p.s 2002, Pardubice, ISBN 978-80-86530-06-2.
 [2] VORLÍČEK, M.: *Selected chapters from mathematical statistics (in Czech)*, Ministerstvo národní obrany Praha, 1968.
 [3] KOŽÍŠEK, J.: *Mathematical statistics and statistics analysis (in Czech)*, Ediční středisko ČVUT Praha, 1981.
 [4] ŠIMÁK, Ladislav: *Crisis management in public administration (in Slovak)*, Žilina, FŠI ŽU, RVS, 2001. ISBN 80-88829-13-5.
 [5] BRANDALÍK, F., KLUVÁNEK, P.: *Operation analysis in railway transport (in Slovak)*, ALFA, Bratislava

Year	Fatal Accidents	Adjusted
Real		
1950	19.000	15.7535322
1960	8.000	6.77178427
1970	1.800	2.91090668
1980	0.900	1.25127697
1990	0.500	0.53787161
1995	0.450	0.35264782
1998	0.300	0.27374031
Forecasted		
2004		0.16494299
2005		0.15158854
2006		0.13931532
2007		0.1280358
2008		0.1176695

prepare necessary capacity of health centres and technical equipment. It involves organisation of rescue fire brigade and medical services as well take the view of administrative work.

This way it is possible to determine data from all spheres of interest. However, the prerequisite is access to information from the past. Data including machine or equipment failures as well as their causes can lead to the series of measures necessary for their elimination. Natural disasters data enable realisation of adequate building, organisational and other measures.

In case of optimum crisis management strategy determination it is mostly necessary to solve conflict between needs and possibilities. Neglect of some of the risk factors can have far-reaching consequences in case of crisis situation origin. Sensible implementation of scientific methods in crisis planning implies optimum solution of emergency situations.

This article has been supported by Agency for Science and Technology by means of financial aid No. 20-001902. and VEGA No. 1/0077/03.

Juraj Cajchan – Oľga Poniščiaková – Miloš Poliak *

SLOVAK ROAD TRANSPORT FROM THE POINT OF VIEW OF SUSTAINABLE DEVELOPMENT

In spite of the various facts transport belongs to the main contaminers of environment, therefore another transport development is contingent on conditions of permanently sustained development.

The article deals with transport negative effects to the environment at present and about expected trends in the near future.

Introduction

The term “sustainable development” was implemented globally in the report by the World Environmental and Development named “Our Common Future” that was discussed by the UN General Assembly in 1987 (The Commission chaired by Harlem Brundtland – the Norwegian Prime Minister – was established by a resolution of the UN General Assembly in 1983). Under this report, sustainable development refers to such developmental methods that satisfy the present needs without harming possibilities of future generations to satisfy their own needs.

Road Transport and Sustainable Development

Transport is considered to be one of the factors significantly affecting economic development. It ensures transports of raw materials, energy resources and energy itself, goods, products and services, as well as of persons and information. From the economic aspect, it is a factor limiting economy. This is evidenced also by a fact seen in Slovakia when the transport branch contributed to GDP with 7.7 % in 2003. Road transport is domineering among various types of transport and its share expressed in tkm increased from 27.51% to 37.37% in the period from 1996 to 2003. On the other hand, transport is a source of enormous atmospheric emissions; therefore it is necessary to consider a revision of the present transport systems in the light of creating a better model and streamlining transport and transportation system management. The fundamental goal of this agenda should be the development and implementation of economically effective strategies and programmes

that allow for a decrease of harmful emissions emitted by means of transport to air, as well as abatement of other harmful impacts of transport on the environment while following developmental priorities, specific local and national conditions and safety considerations.

The increase in the volume of road cargo transport supported by insufficient competition on part of railways in terms of cargo transport, and the increase in individual motorization to the detriment of mass public transport brings about the increase in fuel consumption in the field of transport, what gives a way to tendencies resulting in higher demands on the environment, including impacts on residential zones by noise and emissions of pollutants. The present period can be characterised as a turn to environmentally less friendly means of transport.

Road transport and its impacts on the environment mean not only vehicles, noise and emissions of pollutants. Let’s look at the effects of road transport on sustainable development in Slovakia in broader terms.

Transport Infrastructure

It consists of roads with national importance (class I, II, III) and highways, including their sections in cities and municipalities included into the road network, and buildings required for road transport operation. The Slovak road network comprised 17, 772 km of roads and highways in 2003, of which highways equalled to 313 km. Considering the relief of the terrain, the density of the

Basic Information on Transport Infrastructure

Table 1

Indicator	1993	1994	1995	1996	1997	1998	1999	2000	2001	2002	2003
Length of roads and highways	17 865	17 889	17 869	17 867	17 627	17 710	17 734	17 737	17 736	17 750	17 772
of which highways	198	198	198	215	219	228	295	296	296	302	313

* Juraj Cajchan¹, Oľga Poniščiaková², Miloš Poliak¹

¹Department of Road and Urban Transport, Faculty of Operation and Economics of Transport and Communications, University of Žilina; E-mail: Juraj.Cajchan@fpedas.utc.sk, Milos.Poliak@fpedas.utc.sk

²Department of Economics, Faculty of Operation and Economics of Transport and Communications, University of Žilina; E-mail: Olga.Ponisciakova@fpedas.utc.sk

Slovak road networks is seen as sufficient and comparable with the average in Europe. There are 3.18 km of roads per 1,000 inhabitants. The development of lengths of roads and highways over the period of 1993-2003 is seen in Table 1.

Machinery

The number of vehicles used in road transport keeps increasing. Passenger cars contribute the most to this increase. In spite of this fact, the development in the number of road vehicles used on our roads has had some positive changes, too. They include:

- Increase in the number of vehicles equipped with a catalyst, high energetic efficiency and low production of pollutants in exhaust gases,
- Decrease in the number of passenger motor vehicles with a two-stroke engine,
- Significant improvement in technical condition of vehicles in every category.

These are reasons why the increase in the number of passenger cars in Slovakia is not reflected in higher emissions of pollutants, because it is the increase in ecologically more efficient vehicles rather than vehicles of obsolete generations. The issue of renewal of used up machinery in mass public transport remains to be a problem, as its machinery is depreciated up to 80 % and even its simple renewal is not possible due to scarcity of financial resources.

The development in the number of vehicles used in road transport is shown in Table 2.

Transport Outputs in Passenger and Cargo Road Transport

Development of passenger transportation by means of public mass road transport shows a long-term decrease in the number of transported passengers as well as in the number of total outputs (table 3). This is due to major changes in the division of transportation performances, in which individual passenger transport gets established to the detriment of any other types of mass transport.

The development in transportation outputs in cargo road transport over the period of 1993 - 2003 can be characterised as an increasing-decreasing tendency. Since 1995, it takes over the dominant position on the Slovak market from railway transport and it continues to keep this position.

Fuel and Energy Consumption

The raising tendency in fuel and energy consumption per one thousand of persons transported by road transport is affected by the increasing share of individual car transport and decreasing

Number of Vehicles in Road Transport (pieces)

Table 2

Number of vehicles	1993	1994	1995	1996	1997	1998	1999	2000	2001	2002	2003
Passenger	994 933	994 046	1 015 794	1 058 425	1 135 914	1 196 109	1 236 396	1 274 244	1 292 843	1 326 891	1 356 185
Trucks and pick-ups	101 552	102 470	102 634	97 078	103 080	111 081	115 981	110 714	120 399	130 334	142 140
Special utility	46 121	45 484	45 797	45 430	45 376	43 690	41 670	39 188	36 082	34 150	32 033
Tractors	—	—	—	—	600	1 721	2 306	3 281	4 994	6 837	8 851
Buses	12 655	12 066	11 812	11 321	11 235	11 293	11 101	10 920	10 649	10 589	10 568
Agricultural vehicles	65 150	64 729	64 536	62 810	63 145	63 448	63 493	64 351	63 422	62 644	61 690
Motorcycles	81 263	80 473	81 847	79 479	81 062	100 891	44 215	45 647	46 676	47 900	48 709
Trailers and semi-trailers	167 174	171 125	175 740	176 246	182 893	191 241	197 917	201 269	206 627	213 167	218 517
Others	—	—	—	—	—	—	—	2 226	1 507	1 306	1 161
Total	1 468 848	1 470 393	1 498 160	1 530 789	1 623 305	1 719 474	1 713 079	1 751 840	1 783 199	1 833 818	1 879 854

Developments in Passenger Transportation and Goods Transportation in Road Transport

Table 3

Indicator	1993	1994	1995	1996	1997	1998	1999	2000	2001	2002	2003
Transported persons (thous.)	825 677	761 439	722 510	698 256	667 427	656 230	621 567	604 249	564 078	536 613	493 706
Outputs (mil. pers/km)	11 445	10 574	11 191	11 097	9 969	8 840	7 833	8 435	8 051	8 236	7 757
Goods transport (thousand t)	37 826	28 465	32 043	34 745	41 108	29 889	39 920	39 680	34 773	33 035	30 682
Outputs (mil. tkm)	5 464	4 910	5 158	5 171	3 779	4 715	8 474	7 212	6 557	6 799	6 362

share of public mass transport. Consumption of liquid fuels represents the highest share, whereas the share of particulate and gaseous fuels and electricity is very low. A slight increase in motor diesel consumption can be attributed to higher demands for road cargo transport. The development in consumption of alternative fuels after 1999 shows significant positive changes in the total quantity of LPG consumed, and this can be attributed to the development of individual car transport.

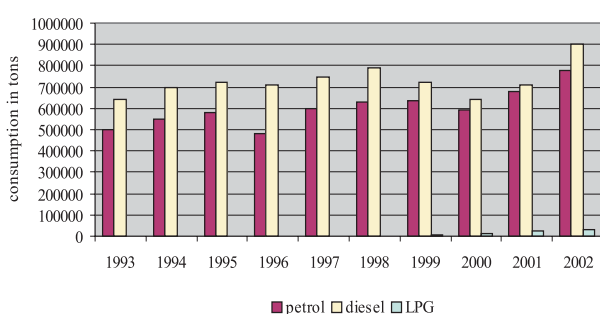

Fig. 1 Developments in total fuel consumption in road transport

Emissions of Pollutants

Development of CO₂ emissions in Slovakia is still higher than the level estimated by pessimistic scenarios of the National Plan for Stabilisation and Decrease of Carbon Dioxide Emissions (CO₂) in Slovak transport for 2010. This is a continuation of the adverse tendency that started in 2001 after the preceding positive development in CO₂ production in transport witnessed in 2000. This adverse development is determined by the increase in fuel consumption in road transport (car petrol by 5.6%, motor diesel by 19.3 % and LPG by 23.6 %) and higher sales of new passenger vehicles.

Waste from Road Transport

A transport waste refers to a movable item, mentioned in Annex 1 of the Act of the National Council of the Slovak Republic No. 233/2001 Coll. concerning waste and amendment of certain acts, its holder disposes, intends to dispose or is obligated to dispose in accordance with this Act or other special regulations. In most cases, this involves harmful waste (parts of decommissioned means

of transport, batteries, parts of exhaust systems of motor vehicles, greasing agents, fuels and similar). Analyses of waste compositions show that waste generated by road transport includes mostly ferrous metals (65-80%), non-ferrous metals (6-6.5%) and tyres (4-5%).

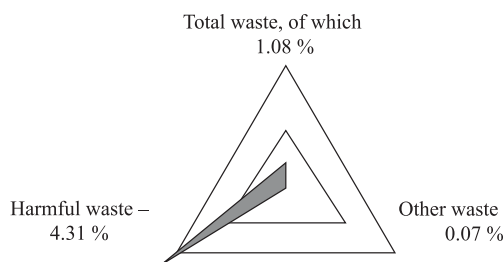

Fig. 2 Share of transport in total volume of waste generated in 2002 (in %)

Number of Accidents and Number of Casualties in Road Transport

An accident is an event caused by a movement of a road transport vehicle resulting in casualties or injuries to health or property no matter whether this event was classified as a crime and/or offence and whether it was brought before a court or a penal commission of a Traffic Inspectorate. Despite of the optimistic decreasing development in the rate of traffic accidents over the period of 1996 to 2000, the following period failed to confirm this tendency. The number of accidents in 2001 and 2002 increased in Slovakia approximately by 10,000 and this trend can be seen also in 2003.

Conclusion

With regard to the anticipated process of economic revival in the Slovak Republic combined with a subsequent increase in the standard of living of its inhabitants, it is necessary to take into account a continuous development of road transport in the future and related increase in fuel consumption resulting in increased production of CO₂ emissions from traffic operations in Slovakia. Negative tendencies associated with such development can be kept at present within acceptable limits only by means of restrictive measures taken by governments focusing on reduction of national expenditures and increase in national revenues in the national budget, by means of increasing vital cost items of inhabitants that

Number of Accidents and Number of Casualties in Road Transport

Table 4

Indicator	1993	1994	1995	1996	1997	1998	1999	2000	2001	2002	2003
Number of accidents	50 159	53 436	60 536	75 607	64 854	57 452	55 683	50 930	57 258	57 060	60 304
Casualties	584	633	660	615	788	818	647	626	614	610	645
Severe injuries	2 736	2 603	2 791	2 691	2 871	3 121	2 684	2 205	2 367	2 213	2 163
Minor injuries	8 682	8 391	8 782	8 927	9 676	9 771	8 782	7 891	8 472	8 050	9 158

would have restrictive effects on developments of individual motorization and the closely associated negative development in fuel consumption. Maintaining this process within the limits of sustainability is an important challenge of the present times.

The contribution was elaborated into solution of project VEGA 1/2615/05 – Economic and qualitative changes and synergic influence on Transport and Logistics after Slovak Republic EU accession.

References

- [1] *Report of Slovak Republic Environment in 2003 (in Slovak)*, Ministerstvo životného prostredia Slovenskej republiky, KOPRINT Banská Bystrica, 2004, ISBN 80-88833-38-8
- [2] *Enviromagazín, magazine of Environment protection and Protection (in Slovak)*, 4/2004, Ministerstvo životného prostredia Slovenskej republiky, Bratislava, ISSN 1335-1877
- [3] *Statistical Yearbook of the Slovak Republic (in Slovak)*, VEDA vydavateľstvo Slovenskej akadémie vied, Bratislava, 2004, ISBN 80-224-0827-1

Alica Kalašová *

INCREASE IN ROAD TRANSPORT SAFETY – WAY TO REDUCTION OF EXTERNAL COSTS

Satellite navigation and prepared navigation system Galileo is the key technology that has to open the gate to new applications. It has to ensure Europe to not be too dependent (in term of economic and safety) on nonmember states of EU, to establish new applications and create new markets with integrated navigation and communication services. In our article we will deal with the opportunities that the new navigation system Galileo will offer for the road transport.

Keywords: GPS, GALILEO, external cost, safety

1. Introduction

The building up of Europe has brought us peace but the war against road rage is far from an end: over half a century, in some countries of Europe, more than two million persons died and almost one hundred million of others were injured in road accidents.

In spite of progress in the long term the overall situation is still a disaster -from the human, social and economic points of view: Europe has now more than 40,000 fatalities and 1.7 million persons injured every year in road accidents, at a total cost estimated at 160 billion €/year.

Some categories of road users or population groups are particularly at risk: young persons between 15 and 24 year of age (10.000 fatalities/year), pedestrians (7.000 fatalities), motorcyclists and moped users (6.000 fatalities), and cyclists (1.800 fatalities). The unacceptable behaviour of road users is the first cause of mortality: excessive speed (15.000 fatalities), consumption of alcohol or drugs, fatigue (10.000 fatalities), non-wearing of seat belts or of protective helmets (7.000 fatalities) [these figures are not cumulative because of the interaction between several causes].

It is obvious that action taken to date has not sufficiently met such a challenge. This is why the Commission has proposed an ambitious target to reducing by 50% the number of road fatalities by the year 2010 [1]. In order to contribute to achieving this target the Commission has published a European road safety action programme. Such a programme offers a framework for all partners and it guides the EU action where its added value is at its most. It aims at

- stimulating road users towards a more responsible behaviour in particular through a better respect of existing rules, initial and continuous training of private and professional drivers and a better enforcement against dangerous behaviour;

- making vehicles safer through improved technical performance standards;
- improving the road infrastructure, in particular through the identification and diffusion of best practices and the elimination of black spots. [1]

2. External cost

One of the most significant factors affecting increase in road transport safety is reduction of external costs. External costs are described as follows.

When consumers decide to purchase an item or take a trip, they examine the price of a given option and compare it to the gain or satisfaction they expect to derive from the item or trip. For instance, an individual wishing to get from A to B will consider the price (of using public transport or his/her private car) and quality of the service provided before opting for a given transport mode. Users are willing to accommodate a whole array of parameters (speed, frequent/regular service, quality, flexibility, etc.) in the transport price they pay.

Conversely, consumers of goods or services do not generally foot the full bill for the costs their decision imposes on society and the environment. Such costs are defined as external because they are not reflected in the price paid by users and are not factors in the market. The main sources of external cost in the transport sector are accidents, congestion, air pollution, noise and climate change. Individuals using a given form of transport are not generally aware of the external cost generated and indeed it is possible that some of these costs have never been defined.

Nonetheless, external costs do exist and since they are not met by the parties responsible, they must be borne by society as a whole.

Significant external costs are: [2]

* Alica Kalašová

Department of Road and Urban Transport, Faculty of Operation and Economics Transport and Communication, University of Žilina, Moyzesova 20, 010 26 Žilina, E-mail: Alica.Kalasova@fpedas.utc.sk

- accidents, when transport systems are used, accidents occur, generating a whole range of costs which are only partly covered by mutual risk insurance schemes (loss of life, medical care and disabilities sustained by victims, loss of production, etc.),
- air pollution, emission of particulate matter, carbon monoxide, lead, volatile organic compounds, nitrogen oxides and sulphur dioxide, damaging health, the environment and buildings,
- climate change, greenhouse gases (mainly carbon dioxide - CO₂) have an enduring impact on the earth's climate, resulting in increased desertification, raised sea levels, serious harm to agriculture and other destructive environmental and health-related side-effect.
- noise, transport generates noise, which adversely affects humans in a variety of ways, causing disturbances, stress and more serious health problems,
- congestion, more vehicles are being added to already dense traffic flows, particularly car traffic flows, paralysing the system and leading to substantial wastage for all users. Congestion makes the entire transport system inefficient.

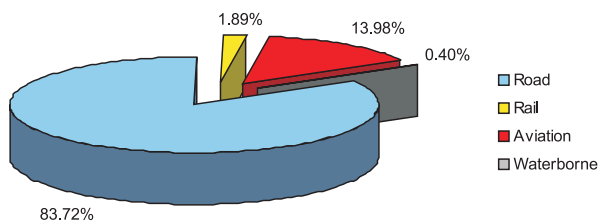

Fig. 1 Share of particular transport sectors in generating external costs

The following figures present the results for total and average costs for year 2000. Total external costs (excluding congestion costs, with climate change high scenario) amount to 650 billion € for 2000, being 7.3% of the total GDP in EU 17 (5%). The most important mode is road transport, causing 83.7% of total cost, followed by air transport, causing 14% of total external costs. Railways (1.9%) and waterways (0.4%) are of minor importance. Two thirds of the costs are caused by passenger transport and one-third by freight transport, see Fig. 1.

In road transport climate change is the most important cost category with 30% of total cost, if high shadow prices are used. Air pollution and accident costs amount to 27% and 24% respectively.

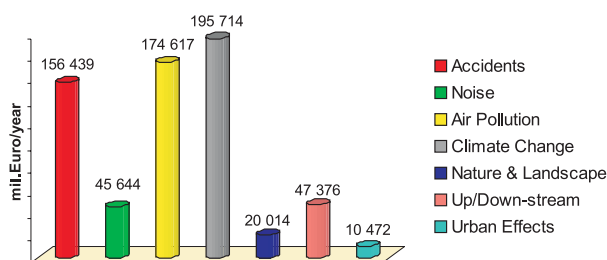

Fig. 2 Share of particular external costs in road transport

The costs for noise and up- and down-stream processes each account for 7% of total costs. The costs for nature and landscape and additional urban effects are of minor importance, see Fig. 2. [2]

3. Satellite navigation systems

Introduction of satellite technologies into road transport is one of possible ways safety increase and external costs dereduction. Present-day satellite navigation systems GPS and GLONASS are known to road transport users. Navigation system GPS is nowadays widely used in vehicles and, together with a digital map of a territory, enables a large amount of before unimaginable applications which make drivers' activities easier. The main disadvantage of GPS and GLONASS systems is their relatively low accuracy with some applications (about 22.5 m) and with augmented system about 5 m.

In 1999 European Space Agency - ESA and European Transport Council - ETC, joint body of European ministers of Transportation, started GALILEO program. Galileo represents global European satellite navigation system, which will meet all high demands for precision, integrity and time alert, continuity and availability to eliminate dependency on to US GPS and provide full utilization of all satellite navigation possibilities focused mainly on civilian applications. Accuracy of the system depends only on the choice of service. Free Open services provide approximate horizontal accuracy from 4 to 15 m and from 8 up to 35 m. vertical accuracy according to the receiver type (single frequency or double frequency). Fee-based Commercial service CS enables significant accuracy improvement in relation to local components. Horizontal location accuracy will be between 0,8 m up to 7 m, vertical accuracy between 1 m and 15 meters according to receiver type. Time accuracy should fluctuate from 10 to 100 ns.

We are not going to describe the whole system, which can be found in particular references [3], [4], etc. but we will point out some possibilities of the Galileo's applications in road transport.

The road sector is a major potential market for GALILEO applications. By 2010 there will be more than 670 million cars, 33 million buses and trucks and 200 million light commercial vehicles worldwide.

Satellite navigation receivers will provide new services to people on the move: electronic charging, real-time traffic information, emergency calls, route guidance, fleet management and Advanced Driving Assistance Systems (ADAS). GALILEO will offer urban travelers an increased availability of satellite signals, reducing the effect of shadowing by buildings. New services to people on the move: electronic charging, real-time traffic information, emergency calls, route guidance, fleet management and Advanced Driving Assistance Systems (ADAS). GALILEO will offer urban travelers an increased availability of satellite signals, reducing the effect of shadowing by buildings. Route guidance using satellite navigation is already a well-established product offered by car manufacturers. The majority of these systems are based on satellite navigation

systems and onboard sensors (odometer and gyros) to compute optimal routes in real-time. However, GPS does not offer sufficient coverage in urban areas to be used alone. GALILEO with its 30 satellites will increase the coverage and accuracy. This will enable manufacturers to use cheaper sensors to fill the satellite navigation gaps (tunnels, narrow streets). Many additional services can be offered, including emergency calls with automated transmission of location, breakdown assistance with communication of the car position together with other information such as the nature of the vehicle's malfunction, and recovery after theft (500,000 cars are stolen and not recovered in Europe alone each year). The monitoring and management of traffic fluidity will be significantly facilitated when a great number of cars are equipped with satellite navigation receivers and guidance systems. For example, if the average speed of the cars equipped with GALILEO receivers in a road sector drops significantly, a control centre can anticipate a traffic jam and suggest that approaching vehicles choose a different route. A very important application will be tracking and managing emergency and rescue vehicles. Combined with dynamic traffic information, an ambulance with a GALILEO receiver and communication link will be able to reach its destination much faster. Traffic lights could be controlled to speed the arrival of an emergency vehicle. Advanced Driving Assistance Systems (ADAS) combine vehicle capabilities to improve mobility and active safety. GALILEO will provide important additional data to ADAS on the vehicle's environment. ADAS then warns the driver of imminent danger or takes full or partial control over the vehicle. For instance, the speed could be reduced by ADAS under bad visibility conditions if the car approaches a tight turn too fast. This function will be possible only with accurate position data of guaranteed integrity furnished by GALILEO and local elements. It is expected that half of the vehicles operating in Europe by 2020 will carry ADAS. GALILEO will offer the possibility to implement new and more advanced methods of user-friendly road charging: charge for the use of particular roads at particular times with particular vehicles, or charge users traveling in a certain urban zone, according to the distance driven. Although there are other techniques for road tolling, only satellite navigation leads to a reliable seamless service thus avoiding isolated system implementation, which puts a burden on user equipment. The vehicle will use GALILEO to determine its location and to store the distance driven on every type of road (charged or free).

Then it reports the results to a monitoring center for a central charging entity to invoice the user. This would work on both inter-urban and urban roads [5].

Using local components of GALILEO will enable. Even sub-meter accuracies. One of the basic requirements for such development is existence of digital map documentation in order to support safe and quick decisions of a driver. This was the aim of Next MAP project – enhanced digital maps for driver assistance applications (2000–2002). It is project of ERTICO and companies Navigation Technologies, TeleAtlas, BMW Group, Daimler Chrysler, Jaguar, Fiat and Renault. Table 1 shows demanded accuracy of geoinformation so that GALILEO system may enable all stated road applications also beyond 2010, including automatic vehicle driving.

4. Conclusion

Last but not least, since a huge number of entities have a role to play towards road safety the Commission has proposed that everyone in authority, with decision-making powers, or acting in an economic, social or representative function should give solemn undertakings and subscribe to a European Road Safety Charter.

Effective operation is dependent on exact determination of real costs in each transport sector. Experiences show that investments in infrastructure draw more vehicles and so there is no decrease in external costs, which means that is hardly possible to solve the problems by means of new road infrastructure. Various studies indicate that a half empty passenger car needs five or six times more energy than a train or public transport.

Externalities interfere with effective distribution of means sources. This brings 2 contradictions:

- society demands more mobility but it
- is less tolerant of increase in external costs.

The main goal is to provide efficient transport one of the most significant is application of satellite navigation. It is estimated that 40 % of new passenger vehicles bought in Western Europe will be equipped with navigation system.

Demanded accuracy of digital maps

Table 1

Roadmap Requirements	2001	2004	2006	2008	2010	2012
Vehicle-position-accuracy (GPS, DGPS, ...)	15 m	3 m	3 m	1-2 m	1-2 m	1 m
Absolute accuracy	5-25 m	4 m	4 m	2-4 m	2-4 m	2 m
Relative accuracy	5-15 m	1-2 m	1-2 m	0.5-1 m	0.5-1 m	0.5 m
Map objects	5-25 m	5-10 m	5-10 m	1-5 m	1-5 m	1 m
Lane width	–	0.5 m	0.5 m	0.3 m	0.3 m	0.3 m
Speed limit	–	5 m	5 m	3 m	3 m	1 m
Priority regulations	–	–	–	Incl.	Incl.	Incl.

It is well-known that geoinformation plays an important role in road transport navigation systems, transport safety systems but also for emergency systems. Information infrastructure which

enables to generate and give interactive information about current situation on the roads is necessary to have desired effect.

References

- [1] www.europa.eu.int.
- [2] SCHREYER, CH, SCHNEIDER, CH.: *External costs of transport update study*, International Railway Union, October 2004, Paris, ISBN 2-7461-0891-7.
- [3] KEVICKÝ, D., KALAŠOVÁ, A.: *Satellite navigation systems*, EDIS ŽU, 2004, ISBN 80-8070-295-0.
- [4] EUROPEAN COMMISSION, ESA: *GALILEO Mission High Level Definition*, September 2002.
- [5] www.ertico.com.

Viera Šukalová – Oľga Poniščiaková *

IT PAYS TO MANAGE HEALTH PROTECTION AND SAFETY AT WORK

Under European Union directives, employers have responsibilities for the safety and health of their workers. Directive 89/391 provides the general framework for health and safety management, risk identification and prevention. The directive has been implemented in national legislation that may include additional requirements. In the Slovak Republic the health and safety work act 1996 required an employer to identify and to control risks to workers and others. An assessment of risk is nothing more than a careful examination of what, in work could cause harm to people, so that we can weight up whether we have taken enough precautions or should do more to prevent harm.

Every year about 5,500 people are killed in workplaces across the European Union, with another 4,5 million accidents resulting in more than 3 days absence from work (amounting to around 146 million working days lost). These accidents are estimated to cost the EU about 20 billion Euro. The problem affects all sectors of the economy and is particularly acute in enterprises with less than 50 workers. Accident prevention is a good business. Accidents and occupational accidents can have a major financial impact. Prevention of accidents has more benefits than just reducing damages. Preventing work accidents, occupational injuries and diseases not only reduces the costs, but also contributes to improving company performance.

Occupational safety and health can affect company performance in many ways, for instance health workers are more productive and can produce at higher quality. A reduction in work/related accidents and illnesses leads to less sick leave. In turn this results in lower costs and less disruption of production processes.

Equipment and working environment that is optimized to the needs of working processes and that are well maintained lead to higher productivity.

Under European Union directives, employers have responsibilities for the safety and health of their workers. Directive 89/391 provides the general framework for health and safety management, risk identification and prevention. The directive has been implemented in national legislation that may include additional requirements. In the Slovak Republic the health and safety work act 1996 required an employer to identify and to control risks to workers and others.

Employers are required to assess risks and take practical measures to protect the safety and health of their workers, keep accident records, provide information and training, consult employees and cooperate and coordinate measures with contractors. A hierarchy of prevention is set including.

Avoid risks at source
Combat risks at source
Adapt work to the worker
Replace the dangerous with the non dangerous, and
Give collective measures priority over individual measures

Companies should ensure the safety and health of workers in every aspect related to their work. Therefore, employers should take the necessary measures for the safety and health protection of workers, including the prevention of occupational risks and the provision of information and training, and provide the necessary organization and means.

Management control of health and safety is cost-effective, safety pays. The true cost of accident can far outweigh the costs of prevention. Poor control of health and safety will mean pressure from enforcing authorities and payment of the legal penalties. The methods for controlling health and safety risks are the same as for controlling quality and protecting the environment. If you fail to manage health and safety you also risk quality and environmental consequences. An assessment of risk is nothing more than a careful examination of what, in your work could cause harm to people, so that you can weight up whether you have taken enough precautions or should do more to prevent harm. The aim is to make sure that no one gets hurt or becomes ill. Accidents and ill health can ruin lives and affect your business too if output is lost, machinery is damaged, insurance costs increase, or you have to go to court.

Risk assessment involves:

- Identifying hazards - what might go wrong?
- Judging who might be harmed and how seriously, including employees, contractors, the public
- Deciding how likely it is to happen
- Deciding how these risks can be eliminated or reduced - can facilities, work methods, equipment or training be improved?
- Setting priorities for action based on size of risk, numbers affected etc.

* Viera Šukalová, Oľga Poniščiaková

Department of Economics, F PEDAS, University of Žilina, E-mail: viera.sukalova@fpedas.utc.sk; olga.ponisciakov@fpedas.utc.sk

- Implementing control measures
- Reviewing, to check that control measures are working
- Including employee consultation in the process and providing information on risk assessment results.

It must be done five steps to risk assessment.

Step 1: Look for the hazards

If you are doing the assessment yourself, walk around the workplace and look afresh at what could reasonably be expected to cause harm. It is better to concentrate only on significant hazards, which could result in serious harm or affect several people. Also employees or their representatives can tell what they think. They may have noticed things, which are not immediately obvious. Manufacturer's instructions or datasheets can also help you spot hazards and put risks in their true perspective.

Step 2: Decide who might be harmed and how

We can not forget people who may not be in the workplace all the time, e.g. cleaners, visitors, contractors, maintenance personnel, etc. Members of the public, or people sharing the workplace with can be hurt also in some cases.

Step 3: Evaluate the risks arising from the hazards and decide whether existing precautions are adequate or more should be done

Even after all precautions have been taken, usually some risk remains. What you have to decide for each significant hazard is whether this remaining risk is high, medium or low. First, ask yourself whether you have done all the things that the law says you have got to do. Your real aim is to make all risks small by adding to your precautions if necessary. Improving health and safety need not cost a lot. For instance, placing a mirror on a dangerous blind corner to help prevent vehicle accidents, or putting some non/slip material on slippery steps are inexpensive precautions considering the risk. Only use the personal protective equipment when there is nothing else that you can reasonably do.

Step 4:

The risk assessment should show that

- a proper check was made
- you asked who might be affected
- you dealt with all the obvious significant hazards
- the precautions are reasonable and the remaining risk is low.

The written document has to be kept for future reference, it helps to show that you have done what the law requires.

Step 5:

Sooner or later you will bring in new machines, substances and procedures which could lead to new hazards. If there is any signif-

icant change, you should add to the assessment to take account of new hazards in any case, it is good practice to review your assessment from time to time. Don't amend your assessment for every trivial change, or still more, for each new job, but if a new job introduces significant new hazards of its own, you will want to consider them in their own right and do whatever you need to keep the risks down.

A structured approach to management ensures that risks are fully assessed and that safe methods of work are introduced and followed. Periodic review checks that these measures remain appropriate. A typical management model:

1. Policy – sets commitment, objectives, responsibilities for the organization.
- 2) Planning – identifies and assesses the risks arising from work activities and how they can be controlled. Activities in the planning process include:
 - risk assessment and identification of prevention measures
 - identifying the management arrangements and organization needed to exercise control
 - identifying training needs
 - ensuring that occupational health and safety knowledge, skills and expertise are available
3. Implementation and operation – involves putting plans into practice. This may mean: making changes to the organization and working procedures, working environment, equipment and products used, training management and staff and improving communications.
4. Checking and corrective action - Performance should be monitored. This can be reactive, e.g. using accident recorders or proactive, e.g. by feedback from inspections and audits and from staff surveys.

Accident investigations should identify the immediate and underlying causes, including management failings. The aim is to ensure that systems and procedures are working and to immediately take any corrective action needed.
5. Management review and audit – allows checking of the management system's overall performance. External circumstances may have changed, e.g. new legislation has been introduced. There is also an opportunity to look forward, e.g. to changes in business structure, development of new products or management level. Auditing examines whether the policy, organization and systems are actually achieving the right results.

Workers have a right to receive information about the risk to health and safety, preventive measures, first aid and emergency procedures. Employees have duties to co-operate actively with employers preventive measures, following instructions in accordance with training given and taking care of their own and work-mates safety and health.

References:

- [1] The health protection and safety work act 1996
 [2] <http://europe.osha.eu.int>

COMMUNICATIONS - Scientific Letters of the University of Žilina Writer's Guidelines

1. Submissions for publication must be unpublished and not be a multiple submission.
2. Manuscripts written in **English language** must include abstract also written in English. The submission should not exceed 7 pages (format A4, Times Roman size 12). The **abstract** should not exceed 10 lines.
3. Submissions should be sent: **by e-mail** (as attachment in system Microsoft WORD) to one of the following addresses: *holesa@nic.utc.sk* or *vrablova@nic.utc.sk* or *polednak@fsi.utc.sk* **with a hard copy** (to be assessed by the editorial board) or **on a 3.5" diskette** with a hard copy to the following address: Zilinska univerzita, OVaV, Moyzesova 20, SK-10 26 Zilina, Slovakia.
4. Abbreviations, which are not common, must be used in full when mentioned for the first time.
5. Figures, graphs and diagrams, if not processed by Microsoft WORD, must be sent in electronic form (as GIF, JPG, TIFF, BMP files) or drawn in contrast on white paper, one copy enclosed. Photographs for publication must be either contrastive or on a slide.
6. References are to be marked either in the text or as footnotes numbered respectively. Numbers must be in square brackets. The list of references should follow the paper (according to **ISO 690**).
7. The author's exact **mailing address of the organisation where the author works, full names, e-mail address or fax or telephone number**, must be enclosed.
8. The editorial board will assess the submission in its following session. In the case that the article is accepted for future volumes, the board submits the manuscript to the editors for review and language correction. After reviewing and incorporating the editor's remarks, the final draft (before printing) will be sent to authors for final review and adjustment.
9. The deadlines for submissions are as follows: September 30, December 31, March 31 and June 30.
10. Topics for the year 2006: 1/2006 - Materials and technologies for electrotechnics, 2/2006 - Energetic machines and equipment, 3/2006 - Informative and communication tools for decision-making support, 4/2006 - Fatigue and endurance of constructional materials.

POKYNY PRE AUTOROV PRÍSPEVKOV DO ČASOPISU KOMUNIKÁCIE - vedecké listy Žilinskej univerzity

1. Redakcia prijíma iba príspevky doteraz nepublikované alebo inde nezaslané na uverejnenie.
2. Rukopis musí byť v **jazyku anglickom**. Príspevok by nemal prekročiť 7 strán (formát A4, písmo Times Roman 12 bodové). K článku dodá autor **resumé** v rozsahu maximálne 10 riadkov (v anglickom jazyku).
3. Príspevok prosíme poslať: **e-mailom**, ako prílohu spracovanú v aplikácii Microsoft WORD, na adresu: *holesa@nic.utc.sk* alebo *polednak@fsi.utc.sk* príp. *vrablova@nic.utc.sk* (alebo doručiť na diskete 3,5") a **jeden výťah** článku na adresu Žilinská univerzita, OVaV, Moyzesova 20, 010 26 Žilina.
4. Skratky, ktoré nie sú bežné, je nutné pri ich prvom použití rozpísať v plnom znení.
5. Obrázky, grafy a schémy, pokiaľ nie sú spracované v Microsoft WORD, je potrebné doručiť buď v digitálnej forme (ako GIF, JPG, TIFF, BMP súbory), prípadne nakresliť kontrastne na bielom papieri a predložiť v jednom exemplári. Pri požiadavke na uverejnenie fotografie priložiť ako podklad kontrastnú fotografiu alebo diapozitív.
6. Odvolania na literatúru sa označujú v texte alebo v poznámkach pod čiarou príslušným poradovým číslom v hranatej zátvorke. **Zoznam použitej literatúry** je uvedený za príspevkom. Citovanie literatúry musí byť **podľa STN 01 0197 (ISO 690)** „Bibliografické odkazy“.
7. K rukopisu treba pripojiť **plné meno a priezvisko autora a adresu inštitúcie v ktorej pracuje, e-mail adresu** alebo číslo telefónu event. faxu.
8. Príspevok posúdi redakčná rada na svojom najbližšom zasadnutí a v prípade jeho zaradenia do niektorého z budúcich čísel podrobí rukopis recenzii a jazykovej korektúre. Pred tlačou bude poslaný autorovi na definitívnu kontrolu.
9. Termíny na dodanie príspevkov do čísel v roku sú: 30. september, 31. december, 31. marec a 30. jún.
10. Nosné témy v roku 2006: 1/2006 - Materiály a technológie pre elektrotechniku, 2/2006 - Energetické stroje a zariadenia, 3/2006 - Informatické a komunikačné nástroje na podporu rozhodovania, 4/2006 - Únava a životnosť konštrukčných materiálov.



VEDECKÉ LISTY ŽILINSKEJ UNIVERZITY
SCIENTIFIC LETTERS OF THE UNIVERSITY OF ŽILINA
7. ROČNÍK - VOLUME 7

Šéfredaktor - Editor-in-chief:

Prof. Ing. Pavel Poledňák, PhD.

Redakčná rada - Editorial board:

Prof. Ing. Ján Bujňák, CSc. - SK
Prof. Ing. Karol Blunár, DrSc. - SK
Prof. Ing. Otakar Bokúvka, CSc. - SK
Prof. RNDr. Peter Bury, CSc. - SK
Prof. RNDr. Jan Černý, DrSc. - CZ
Prof. Ing. Ján Čorej, CSc. - SK
Prof. Eduard I. Danilenko, DrSc. - UKR
Prof. Ing. Branislav Dobrucký, CSc. - SK
Prof. Dr. Stephen Dodds - UK
Dr. Robert E. Caves - UK
Dr.hab Inž. Stefania Grzeszczyk, prof. PO - PL
PhDr. Anna Hlavňová, CSc. - SK
Prof. Ing. Vladimír Hlavňa, PhD. - SK
Prof. RNDr. Jaroslav Janáček, CSc. - SK
Dr. Ing. Helmut König, Dr.h.c. - CH
Prof. Ing. Gianni Nicoletto - I
Prof. Ing. Ludovít Parilák, CSc. - SK
Ing. Miroslav Pfliegel, CSc. - SK
Prof. Ing. Pavel Poledňák, PhD. - SK
Prof. Bruno Salgues - F
Prof. Andreas Steimel - D
Prof. Ing. Miroslav Steiner, DrSc. - CZ
Prof. Ing. Pavel Surovec, CSc. - SK
Prof. Ing. Hynek Šertler, DrSc. - CZ
Prof. Josu Takala - SU
Prof. Ing. Hermann Knoflachner - A

Adresa redakcie:

Address of the editorial office:

Žilinská univerzita
Oddelenie pre vedu a výskum
Office for Science and Research
Univerzitná 1, Slovakia
SK 010 26 Žilina

E-mail: *komunikacie@nic.utc.sk*, *polednak@fsi.utc.sk*,

Každý článok bol oponovaný dvoma oponentmi.
Each paper was reviewed by two reviewers.

Časopis je excerptovaný v Compendexe
Journal is excerpted in Compendex

Vydáva Žilinská univerzita
v EDIS - vydavateľstve ŽU
J. M. Hurbana 15, 010 26 Žilina
pod registračným číslom 1989/98
ISSN 1335-4205

It is published by the University of Žilina in
EDIS - Publishing Institution of Žilina University
Registered No: 1989/98
ISSN 1335-4205

Objednávky na predplatné prijíma redakcia
Vychádza štvrtročne
Ročné predplatné na rok 2005 je 500,- Sk

Order forms should be returned to the editorial office
Published quarterly
The subscription rate for year 2005 is 500 SKK

Jednotlivé čísla časopisu sú uverejnené tiež na:
<http://www.utc.sk/komunikacie>
Single issues of the journal can be found on:
<http://www.utc.sk/komunikacie>