

5

**FACULTY OF OPERATION AND ECONOMICS
OF TRANSPORT AND COMMUNICATIONS**

17

FACULTY OF MECHANICAL ENGINEERING

27

FACULTY OF ELECTRICAL ENGINEERING

45

FACULTY OF CIVIL ENGINEERING

67

**FACULTY OF MANAGEMENT SCIENCE
AND INFORMATICS**

81

FACULTY OF SPECIAL ENGINEERING

91

FACULTY OF SCIENCE

99

**INSTITUTE OF INFORMATION
AND COMMUNICATION TECHNOLOGIES**

105

**CENTRE FOR TRANSPORT
RESEARCH UNIVERSITY OF ŽILINA**



Forewords

The University of Zilina has a strong position between Slovak leading research institutions. Our vision for the future puts research and research-based training as well as internationalization to the center of our strategy. We have been successfully involved in the Framework Programme 5, coordinating projects in addition to being key partners in many more. Therefore, we have a particular commitment to participation within the European Research Area, having close links with partners in this country and the wider world. Through networking of researchers and clustering of universities, opportunities have been created for students to study abroad and international students to study in Zilina. The special University's units are promoted to facilitate the transfer of technology and the spread of technical skills, and to stimulate partnerships between the science, engineering and technology base.

This issue of the journal reflects our aim to become more transparent about the University research, with believing that it would help people both inside and outside to learn about the works that are carried out here. But we have only been able to showcase a small proportion of the research topics that have been coordinated.

However, there are contact points through the paper, so if you think that your expertise, your situation or your network would benefit from joining forces with University of Zilina, please feel free to contact us.

Ján Bujňák



FACULTY OF OPERATION AND ECONOMICS OF TRANSPORT AND COMMUNICATIONS

FACULTY OF OPERATION AND ECONOMICS OF TRANSPORT AND COMMUNICATIONS

Veľký diel NF, 010 26 Žilina, Slovakia
Phone: +421-41-5133011, Fax: +421-41-5651499

Dean

prof. Ing. Tatiana Čorejová, PhD.
E-mail: corejova@fpedas.utc.sk

Vice-Dean for Foreign Affairs

doc. Ing. Luděk Beňo, PhD.
E-mail: beno@fpedas.utc.sk

Vice-Dean for Education Affairs

doc. Ing. Jozef Majerčák, PhD.
E-mail: majercak@fpedas.utc.sk

Vice-Dean for Research and Development -

prof. Ing. Jana Štofková, PhD.
E-mail: stofkova@fpedas.utc.sk

The Faculty of Operation and Economics of Transport and Communications provides university education and prepares specialists for solution of management, technology, economic problems and for business activities especially in sphere of transport, postal services, telecommunications as well as in sphere of business management and economics, banking industry and three-level education system of banking.

Education and research of the faculty are oriented especially to solution of these problems:

- transport, postal and telecommunication policy and identification of socially optimal level of transport, postal and telecommunication systems,
- solution of technology procedures of several kinds of transport, postal services and telecommunications,
- economics and management of network industries,
- efficiency and quality of network systems especially in transport, postal services and telecommunications,



- monitoring of costs in sphere of transport, postal services and telecommunications according to technology and external influences, questions of internalization of external costs,
- application of controlling in infrastructure companies,
- financing of transport, postal and telecommunications projects,
- creating of mass transport systems and appreciation of road mass transport and urban passenger movement,
- demand and supply interactions in transport, postal services, telecommunications and information networks in relation to the market structure and structure of economy,
- diagnosing of business environment in transport, postal services and telecommunications, engineering of suitable diagnostic methods in transport, postal and telecommunications companies and effective settings of therapy in these companies,
- components work motivation structure in networks,
- harmonization and integration of transport operation management systems,
- regional sciences, economics and policies focused to allocation theory of companies, transport and exploitation of territory, economics of public sector, regional dynamics, regional policy and regional integration.

The faculty has the following departments:

- Department of Road and Urban Transport
e-mail: kcmd@fpedas.utc.sk
- Department of Air Transport
e-mail: srogon@fpedas.utc.sk
- Department of Communications
e-mail: ks@fpedas.utc.sk
- Department of Railway Transport
e-mail: kovac@fpedas.utc.sk
- Department of Water Transport
e-mail: zarnay@fpedas.utc.sk
- Department of Economics
e-mail: ksv@fpedas.utc.sk
- Department of Mathematics
e-mail: balint@fpedas.utc.sk

Tatiana Čorejová – Mária Rostašová

DIAGNOSTIC APPROACH IN PROCESS ENHANCEMENT IN POSTAL SERVICE

Diagnostics and measurement of the quality are the basis of measures as for efficiency improvement of the whole postal technological system in connection with customers' expectations as well as competition and regulator behaviour. The quality diagnosing can be defined as a process of search and analysis concerning the quality problems and their reasons. The diagnostic approach in postal service involves several process steps, namely the following ones: definition of normality limits (a fixed limit can be replaced by an allowable interval), normal behaviour definition of an object of diagnostics within the normality limits, ability to change or influence the behaviour of the object of diagnostics – of a process or activity.

The effectively and systematically applied diagnostics in postal service is a very useful tool, provided we are able to properly qualify the connections, by which abnormality problems arise and provided we are able to properly identify the main problems in the technological system of postal activities and processes.

In order to develop knowledge in the quality diagnosing in postal service, the staff from the Department of Communications (Faculty of Operation and Economics of Transport and Communications, University of Žilina) solved several scientific and research projects – the grant tasks VEGA Nos. 1/5270/98, 1/8336/01, 1/9357/02 as well as projects within business activity, where the particular techniques and methods of the quality diagnosing concerning the transport of items were proved. Getting to know the hierarchical system of quality indicators in postal service was one of the problems and results that were solved.

It is necessary to understand the postal diagnostic system as the hierarchical system with the four following intersecting levels:

- The level of the whole establishment, which involves the diagnosing support by creating the quality policy and objectives in postal service and by detecting the problems during their performance.
- The departmental level. The object of diagnostics is decomposed from the level of the whole establishment into the level of particular departments. The functional view of passing phenomena is used.
- The level of processes which pass through the departments in a postal service horizontally, vertically as well as diagonally.
- The level of quality diagnosing concerning particular postal products where data relating to a specific postal product and its values of quality criteria are processed.

The pyramid of indicators for quality diagnostics in a postal service is shown in figure 1.

The achieved results in solving the projects meaningfully contribute to knowledge development in the sphere of improving diagnostics of macro-, mezzo-, and microenvironment in transport of items by post offices. New theoretical knowledge in the quality diagnosing in transport of items, in trend of change as for the quality parameters during the transport of items, and furthermore in the sphere of determining factors which affect the quality of transport of items and their incorporation in quality management systems was obtained.

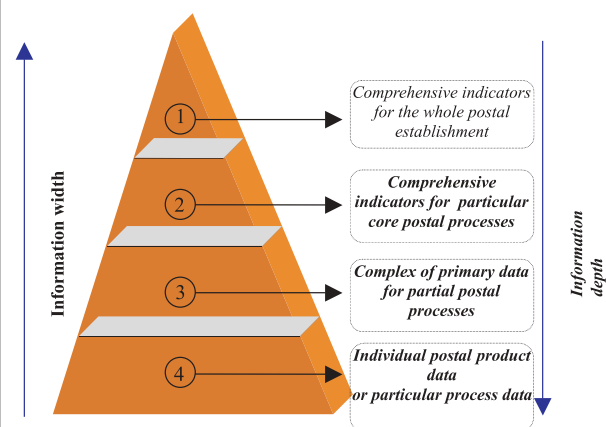

Fig. 1 Pyramid of the indicators for quality diagnostics in postal service.

References:

- [1] ČOREJOVÁ, T. et al.: *Tools for diagnosing of environment in postal services*. In: Final report of project VEGA 1/5270/98, Žilina, 2000
- [2] ČOREJOVÁ, T. et al.: *Methods for diagnosing of quality in postal services*. In: Report of project VEGA 1/8336/01, Žilina, 2002
- [3] KREMEŇOVÁ, I. et al.: *Investigation of postal operators productivity increasing on the EFQM basis*. In: Report of project VEGA 1/9357/02, Žilina, 2002
- [4] ACHIMSKÝ, K. et al.: *End-to-end measuring transit time – 1st class letters, ordinary letters, postal money orders*. In: Projects 1998, 1999, 2000, 2001, F PEDaS, Žilina

MEASURING METHODOLOGY FOR REAL BUS-STOP DISTANCES OF MASS PASSENGER TRANSPORT LINES

Request for measuring the real mass passenger transport lines distances originates from the Act of the National Council of the Slovak Republic No. 168/1996 Coll., on the Road Transport (Article 13, par.2) and the Decree of the Ministry of Transport, Posts and Telecommunications of the Slovak Republic No 311/1996. Coll., (Article 10 par. 3), implementing the Act of the National Council of the SR. The measurement shall be carried out in compliance with the text of the Act of the National Council of the SR No 142/2000 Coll., on metrology and amendment to some acts (Article 20, par. 2). It should be mentioned, however, that any measuring methodology has not been elaborated in the Slovak Republic yet and this legislation has solved this problem generally only, which caused a great number of conflicts, even law-suits [3]. The measuring methodology for real bus-stop distances of mass passenger transport lines has been elaborated by the Road and Urban Transport Department staff.

This methodology gives the principles and procedures for measurement of real distances between bus-stops of mass passenger transport lines, the results of which constitute the basis for determination of tariff distances between the bus-stops on the transport lines. The tariff distance is the basis for calculation of basic passenger fare, payment for carriage of luggage, domestic animals and bus consignments. The methodology is important for the acknowledgement of public service performances.

The methodology No 02/2002/KCMD [1] is generally valid and after its validation by the Ministry of Transport, Posts and Telecommunications on 21. 2. 2002 can be used only by the persons authorised by this body for carrying out the specified activity. This methodology links up the "Measuring methodology for distances by the measurement and reporting instrument Correvit", which was also elaborated by the Road and Urban Transport Department staff and validated by the Slovak Metrological Institute on 20. 2. 2002 [2]. The operating principle of the CORREVIT system is illustrated by Figure 1.

The main part of the system CORREVIT is developed by an efficient and precise optical-electronic sensor designed for tasks solutions at measurement of dynamic characteristics of the road transport.

The Sensor *L* (Fig. 1) serves for measurement of distances. It enables touch-less scanning of the vehicle's speed in the longitudinal direction from 0.5 to 200 km.h⁻¹ with $\pm 0.3\%$ tolerance and is confirmed by calibrating protocol of the manufacturer.

The operating principle for measurement of longitudinal part of a vehicle speed is the following. The road surface (1), which is

a "measuring object", is illuminated by an optical path of rays from the source of light (2) with a 50 W bulb. The picture of measuring object (illuminated part of the road surface) is transferred by reflected union beams of light through the optical system (3) on the prism grating (4) in which it is collected on two photo-electric detectors – photons (5).

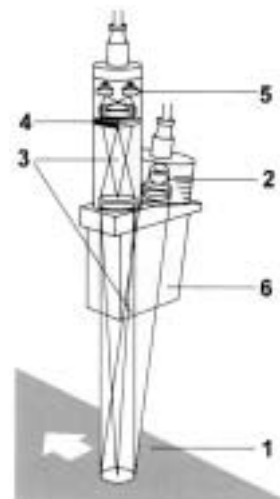

Fig. 1 Optical-electronic Sensor *L*

The staggered signals generated by the detector are identical apart from a phase displacement of 180° in their modulation component. The push-pull components can be separated from the low-frequency common-mode components by a differential amplifier and further amplified separately.

Measured data are stored into the memory of the system and possibly recorded on 3¹/₂" diskette. It can be in an arranged or non-arranged data form. The evaluation system by the software mode gives the graphical results visualization or numeric visualization through the internal printer on the plate paper. The evaluation and data processing is made by the hard programs in which it is possible choose measurement steps in advance in combination with the time, track and speed. It is possible to do some complementary mathematical processing with analogue and digital visualized dignities.

The research results are implemented in:

- learning; the system alone enables to simulate the condition for measurement at the Department of Road and Urban Transport

Laboratory, it enables measurement demonstrations for students and to print the results,
 - in practice - the methodology has already been implemented for measurement of bus-stop distances in the mass passenger transport lines: the Slovak Bus Service Nové Zámky, a.s., transport companies Šaľa, Levice, Šahy, Želiezovce and Komárno, the Slovak Bus Transport Trnava, a.s., the transport company Piešťany and the Urban Mass Transport Trnava.

Nowadays, from the initiative of the Bus Transport Union which integrates all Slovak Bus Service companies in the SR and other companies of bus service, there is a tendency either to integrate the specified methodology or its systemic use in the amended Decree No 311/1996 Coll., implementing the Act on the road transport.

References:

[1] CAJCHAN, J., GNAP, J.: *Metodika merania skutočných vzdialeností zastávok liniek hromadnej osobnej dopravy*, č. 02/ 2002/ KCMD, Žilinská univerzita, F-PEDaS, Žilina 2002, 9 s.
 [2] CAJCHAN, J., GNAP, J.: *Metodika merania vzdialeností meracím a vyhodnocovacím zariadením CORREVIT*, č. 01/2002/ KCMD, Žilinská univerzita, F-PEDaS, Žilina 2002, 16 s.
 [3] GNAP, J. A KOL.: *Ekonomické a kvalitatívne vplyvy implementácie legislatívy EÚ do legislatívy SR v oblasti cestnej dopravy*, Projekt VEGA č. 1/8183/01, ŽU v Žiline, F-PEDAS, 2002

Tatiana Čorejová – Mária Rostašová

METHODS AND TECHNIQUES OF COMPANY DIAGNOSING

Modern world of business is subject to many changes with incoherent character and they are results of several progressing processes in companies and environment. New business opportunities follow from asymmetric information, motions and changes. Economic science reflects changes of state, significance and utilization of production factors. Attention is shifted to valuation of velocity and intensity of changes by the valuation of individual business subjects and their successfulness. There is enforcing total view and understanding of a company and criteria of its successfulness are based on financial characteristics, characteristics of the company attractiveness, innovation abilities of the company etc.

We are meeting with problems of diagnosing and company therapy along with solution of logistic and controlling questions at

international and homeland conferences. Attention of the scientific community is concentrated on methodologies of these disciplines and within the scientific community on practical utilization of individual methods and techniques of business. It results from the strengthening of interdisciplinary approaches to solution of company and business problems. These questions were in the center of attention of various research tasks solved in collaboration with the Faculty of Economics of VŠB-TU Ostrava in the Czech Republic and University of Management in Czeszochowa, Poland. One of the results of project is a process of how to make it easier for a diagnostician, manager or consultant to select a method or technique to specify a diagnosis and therapy of the company (see table No 1).

Table 1

Phases	Steps	Suitable actions for individual steps	Example of available methods, techniques and tools
Diagnosis	0 Input	Recognition of change as a difficult process	Utilization of terms: "chaos" and "trouble" Use of diagrams
	1 Inscription	Understanding and structuring of change as a system Acquirement of other suggestions for change or possibility of change	Convene of individual meetings (NGT, DELPHI) Creating of model of actual state
	2 Identification of aims and restrictions	Estimate of aims for examined systems Thinking of aims of the changes	Creating a "tree of aims" Estimate of priorities of aims of change
	3 Formulation of measure of aims	Decision of valuation method of achieved aim	Financial or scale expression of achieved aim

Phases	Steps	Suitable actions for individual steps	Example of available methods, techniques and tools
Suggestion of therapy	4 Creating of volume of alternative possibilities	All ideas to develop as complex possibilities Analysis of wide spread of possibilities Survey of known aims and possibilities of business praxis	Brainstorming Talks and investigations Benchmarking
	5 Selective modeling of possibilities	Specification of most promising possibilities up to specific details (what and who is needed, how it will work)	Diagrams as the easiest models Analysis of costs and advantages Cash-flow models Computer simulations
Realization of therapy	6 Appreciation of possibilities by defined aims	Testing of outputs of possibilities in compare with agreed list of criteria	Creating of easy matrix for comparing of outputs of its own possibilities Items up of each possibility according to aims
	7 Suggest of strategy of realization - implementation	Selection of preferred possibilities and planning of way of realization of changes	Looking for possibilities with high level of reliability Repeated arbitration of "problem owners" Creating timetable and responsibility for realization of individual tasks
	8 Realization of planned changes	Creating of teams and sources Managing of change process Monitoring of progressing	Establishment of people connected to process Assignment of responsibility and competence Re-recording and change of plans in the case of necessity (e.g.: analysis of critical path etc.)

Benefits of the projects solutions are the following:

- development of knowledge and deepening of theories from a sector of company diagnosing,
- establishment of criteria for evaluation of "company health",
- comparison of methods and processes,
- creation and completion of diagnostic methods for a company diagnosing,
- utilization of results of pedagogical activities of the department, faculty and University.

Literature:

- [1] ČOREJOVÁ, T. et al.: *Tools for diagnosing of external and internal environment of company*, Final report of project within

the Agreement between the government of the Slovak Republic and Czech Republic about VTS 2000 – 2001; No. 186/134, Žilina 2001

- [2] ROSTÁŠOVÁ, M. et al.: *Management of changes in conditions of network organizations*, VEGA 1/9186/02
- [3] STRENITZEROVÁ, M.: *Model of "Managing of people sources" process in conditions of huge network companies*, POSTPOINT 01, EDIS Žilina 2001
- [4] ŠTOFKOVÁ, J.; KAŠTÁNEK, P., ROSTÁŠOVÁ, M., ŠTOFKO, S.: *"Finances in postal service and telecommunications I."*, EDIS, Žilina, 1999

Ondrej Buček

NEEDS AND CONCEPTION OF RESTRUCTURING AND TRANSFORMATION OF RAILWAYS

The process of restructuring and transformation of railways has been brought up by the crisis of railway net systems in particular countries. Generally, two following stages are present:

- first stage – disestablishment – denationalization – meaning assignment of state property to another institution, e.g. in our country or eventually in several further post-communist countries to the Fund of national property,

- second stage – privatization.

1. Statement of needs for restructuring and transformation

In the frame of a contemporary enterprise and its property several forms of privatization can be implemented, either in the relation towards the enterprise's property as a whole, or in the

relation to its particular parts, generally with the aim to create independent private-legal subjects.

Presumption for successful privatization is a detailed preparation of the entrepreneur's strategy project. Its main components are designed in the following diagram.

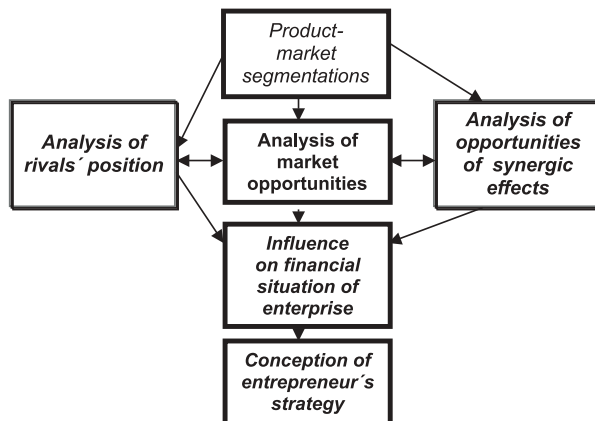

Fig. 1 Preparation of entrepreneurs' strategy

2. Conceptual problems of privatization and transformation

Privatization itself deals mainly with the following spheres:

- concentration of financial resources and financial stability
- internal operating co-operation
- optimal exploitation of capacities
- degression of fixed costs
- complexity of service for customers and
- combined execution of advisory and service processes.

The basis for the defining of privatization is the identification of needs of restructuring. Schematic relation between objectives and forms of privatization is presented in the following diagram:

The privatization project should be based on the entrepreneur's intentions which should enable a long-term prosperity of the

subject in question. The quality of entrepreneur's goals is of great importance for the process of privatization. The more persuasive prognosis of the expected prosperity, the more quickly a potential buyer for the whole or for a part of the enterprise's structure both abroad and at home market can be found. When restructuring the parts, it is important to investigate the effects on the whole. In this sphere wrong procedures are very often used. The prosperous parts are sold while the others, having brought mainly negative financial results, are left as a burden to the original organization (state). And if it is a necessary section, the state has to ensure it from its own resources.

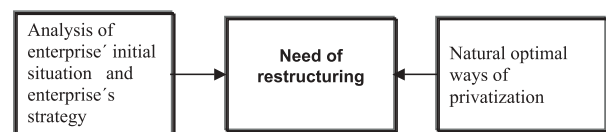

Fig. 2 Identification of restructuring needs

In the privatization process besides non-standard (coupon) method are, above all, used the following standard methods:

- direct sale,
- public vendue,
- public tender.

The properties within funds of national property can be privatized by means of basic methods, as follows:

- by founding of a joint stock company or other commercial company,
- by selling of the enterprises' property or of its part,
- by assignment of the privatized property to the municipalities,
- by assignment of the privatized property for purpose of health and retirement insurance, etc.

References:

- [1] BUČEK A KOL.: *Transformácia železníc vo svete*, EDIS ŽU v Žiline, 2002

Karel Havel – Roman Bíro – Dušan Bonda

TRENDS IN AIR TRAFFIC CONTROLLERS TRAINING IN UNIVERSITY OF ŽILINA

The paper describes an applied and planned training structure for training of air traffic controllers in Slovakia in cooperation with the Air Traffic Services of the Slovak Republic. Initial Training consists of basic training and qualification/endorsement training. Initial Training is designed to enable a student to progress to

a specialized training in the unit. Operational Training is a training given in the operational work situation and following the institutional training. It comprises Transition Training, pre-On-the-Job Training and On-the-Job Training. Transition Training Phase follows after Initial training during which skills will be developed through

the use of site-specific simulations. Pre-On-the-Job Training Phase will enhance the development of previously acquired abilities to a high level of achievement. On-the-Job Training is a 'live training' where previously acquired skills are further developed under the supervision of a qualified coach in an operational situation.

Basic Training is performed at the University of Žilina and is approved by the Civil Aviation Administration of the Slovak Republic.

After the training conducted at our university the student moves to the Air Traffic Services of the Slovak Republic. The first part of training will ensure that the student is made familiar with site specific items. This is done through Transition Phase and Pre-OJT Phase.

Then s/he will proceed to On the Job Training, under the coaching of a practicing controller. The result of this training is the working controller and s/he continues throughout the lifetime in further training so that standards can be maintained.

The cooperation of the University of Žilina and the Air Traffic Services of the Slovak Republic in the training of air traffic

controllers results in a training structure which fully satisfies requirements of Eurocontrol. Basic Training performed at the University gives knowledge to enable a student to progress to qualification/endorsement training at the premises of the Air Traffic Services of the Slovak Republic. This is followed by Operational Training given in the operational work situation. It comprises Transition Training, pre-On-the-Job Training and On-the-Job Training.

References

- [1] *Guidelines for Common Core Content and Training Objectives for ATCOs Training (Phase II)*, HUM.ET1.ST05.DEL02, 1999
- [2] *Guidelines for common core content and training objectives for air traffic controllers training (phase I)* HUM.ET1.ST05.1000-GUI-01, 1997
- [3] *Guidelines for common core content and training objectives for air traffic controllers training (phase II)* HUM.ET1.ST05.1000-GUI-02., 2000
- [4] *European Manual of Personnel Licensing - Air Traffic Controllers*, HUM.ET1.ST08.10000-STD-01, 2000

Tatiana Čorejová – Jana Štofková

PROJECTS FOR REGIONAL DEVELOPMENT

The task of public sector is to improve the quality of life of inhabitants. The public sector will be oriented to increase of internal efficiency and to enhancement of immediate intercommunication with public in the future. Public services are often marked by inadequate number of managers, who are able to harmonize political and economic aims, to balance mixture of sources and administrative restrictions, which are the natural part of public sector environment.



In the frame of the public administration reform in the Slovak Republic and in the frame of integral processes in the European Union (EU, Euro-regions etc.), it is necessary to develop the personal education system on individual levels in public administration and with the development of participating democracy is connected

the problem solution in several regions and locations. From these requirements resulted the solution of various projects which are coordinated by the staff of department of communications, at the Faculty of Operation and Economics of Transport and Communications of the University of Žilina: TEMPUS PHARE Institutional Building Project - Managerial Development of Civil Servants (MADECISE) 1999-2002; VEGA Project - Marketing support of regional development; Projects of international scientific-technical cooperation.

In the frame of these projects solution several interesting results were achieved such as creation and realisation of education system for public administration staff in the sphere of EU law in conditions of public administration institutions, EU fiscal policy, international economic and monetary relations, evaluation of fixed assets and companies and several aspects of public management. Further result was a creation of information and educational centre MADECISE - IVEC as an important output to ensure long-lasting growth in collaboration with partners who are participating in the program realization (Fontys Eindhoven, HTW Dresden, Deutsche Telekom, AG, Citta di Motta di Livenza, TU Zvolen, UMB Banská Bystrica and 24 institutions of public administration in the Slovak Republic).

The basis of cross border cooperation projects was given by the agreement among the Regional Office in Žilina, GIG Kato-

wise, the former Bielsko-Biala Ducal Office, on the basis of which the study: "Program of economic and social activation of cross border areas" was completed.

In the frame of Beskydy Euro-region several marketing researches and international comparisons were carried out. They aimed at methodology development for marketing searching in regions. It is possible to say that from the Euro-regions activities results the following: the socio-cultural aspect of cross border cooperation is a very important basis for higher form of cooperation in the economic sphere. But it is necessary to appreciate and to solve the problem of barriers.

It is possible to identify the barriers in development process of cross border cooperation and they result from several causes, especially from language, cultural, juristic and institutional differences. Although these barriers do not necessarily have to include the area aspect, many of them are clearly showing in the area. The barriers resulted from defined state boundaries or region boundaries. Their basis is connected with defined conditions in the market sphere, international relationships, internal fiscal and monetary policy.

It is important to perceive some differences in the development in the Slovak Republic, Czech Republic and Poland in the last ten years:

- Czech Republic - average living standard and average income are best among these countries,
- Poland - It is a quickly growing country although the total prosperity among population increases very unequally. It has the lowest GDP per citizen,
- Slovak Republic - negative economic period with high unemployment rate, in the sense of Center-European measures.

On the basis of our research we can conclude:

- The main barriers in the Internet commerce development in these countries are related to the Internet level penetration, level of telephone charges, eventually charges for connecting,
- The state of Legislation in e-commerce (although laws about electronic signature are accepted in all of these countries), certain disbelief in on-line commerce or low level of awareness about e-commerce advantages, especially among companies and the rising of internet markets number with low level of offered services.

Initial indicators for valuation of level of Internet trades Tab. 1

Indicator	CZE	POL	SVK
Number of Internet trades	2800	800	515
Population (in mil. 1998)	10.3	38.7	5.4
GDP per citizen / in Euro (1998)	12200	7800	9300
Penetration of internet / in % (2001)	11	11	7
Penetration of personal Computers / in % (2001)	14	7	13
Penetration of HTS / in % (2001)	40	29	32
Number of Internet trade per 100000 citizens.	27.18	2.07	9.53
Number of evaluated trades	200	200	200
- percent of total number	7.14	25	38.8
- number of functional trades	170 (85%)	175 (87.5%)	165 (82.5%)
- number of inaccessible trades	30 (15%)	25(12.5%)	35 (17.5%)
- number of B2C	29.4%	69%	71,5%
B2B	4.9%	0%	3.6%
B2C + B2B	65.7%	31.0%	9.1%

References:

- [1] ŠTOFKOVÁ, J. et al.: *Marketing support of regions diagnosing*. VEGA 1/8010/01
- [2] *Final report*, TEMPUS PHARE IB_JEP-14380-1999 MADE-CISE, 2002
- [3] ŠTOFKOVÁ, J. et al.: *MVTS SK-PL project Pol/Slov/01* Methodology of marketing survey of business in cross border region of Beskydy Euro-region
- [4] BINDA, J.: *Podstawy sieci komputerowych*. WSBiF Bielsko - Biala, 2003
- [5] ŠTOFKOVÁ, J., ACHIMSKÝ, K., ROSTÁŠOVÁ, M., ŠTOFKO, S.: *Program of economic and social activation of boundary areas*. Žilina University in Žilina, 1998
- [6] Collective of authors: *Rozwoj Eurergionu Beskidy. Doswiadczenia-Oczekiwania-Perspektywy*. Materiały konferencyjne, 2002, NR 2, Bielsko-Biala, ISSN 1429-673X



Transformation of Railways in the World

doc. Ing. Ondrej Buček, PhD.
Ing. Anna Tomová, CSc.
Ing. Viera Bartošová
Ing. Alžbeta Bielíková
Ing. Danka Harmanová, CSc.
Ing. Darina Chlebková, CSc.

ISBN 80-7100-946-6 EDIS-Publishing House. Žilina University in Žilina 2002

This scientific publication was originated on the basis of investigation of the transformation of railways in the world, namely on the analysis of the situation of 20 exquisite railways. Most thoroughly were analyzed railways in western Europe together with some countries of CEFTA. Experience from Japan, New Zealand, Mexico and Canada was also significant. The analysis dealt with the investigation in these countries as well as with individual steps of railway transformation, probable consequence of which eventuated into privatization in some countries. Thus, the publication evaluates the starting-points of the situation conditions of railways before the implementation of transformation. It was not only the technical situation but mainly the economic profit which led to the necessity of looking for new ways of restructuring and following transformation of railways. This publication was also prepared as a source for the analysis of steps in transformation of the Slovak Railways. This publication as well as its sources, based on extensive predeceasing research from 1996, points out the presumptions together with the effects of possible transformation.



Diagnostic Process in Quality Management in Post-offices

prof. Ing. Tatiana Čorejová, PhD.
doc. Ing. Mária Rostášová, PhD.

ISBN 80-7100-619-X, University of Žilina, 1999

The monograph is devoted to topical problems of quality diagnosing in the sphere of transport of items. The need of diagnosing and measuring quality of the postal products is determined by several factors and finally it focuses on the main objective that is customer's satisfaction.

The aim of this monograph is to outline the merits of the diagnostic approach in quality management in postal sector and, therefore, it is divided into two parts. The first part is devoted to the terminological and methodical basis of the quality management - to solving the problems as for quality in business practice, paying particular attention to the processes concerning the transport of items. The second part includes methodical directions for using the diagnostic process in the quality management in relation to the appropriate methods for the quality diagnosing in processes of the transport of items. The application of diagnostic approaches, which is proposed in the monograph, offers opportunities for knowing the existent standing of a postal establishment on the market, knowing its own chances of the existing opportunities utilization and it is a primary assumption for specifying reasonable objectives, elaborating an appropriate strategy and its method of realization as well as for long-term development and survival of an establishment.

The monograph is for full-time and part-time students of the University of Žilina, for post-graduate students as well as for scientific and professional staff concerned with quality management problems and quality diagnosing. Its content relates directly to the solution of the scientific grant project VEGA 1/5270/98 "Tools of environment diagnostics in transport of items".

Finances at Post-offices and Telecommunications

prof. Ing. Jana Štofková, PhD.

Ing. Pavel Kaštánek

doc. Ing. Mária Rostašová, PhD.

doc. Ing. Stanislav Štofko, CSc.

ISBN 80-7100-580-0

The monograph deals with financial problems of infrastructure sectors. Post-offices and telecommunications belong also to these sectors. It is an invariable fact that sudden development of telecommunications is effected by convergence of telecommunication and information technologies and media. The monograph includes introduction to problems of company finances. A significant part deals with categories of financial decision making of company.

The publication mentions problems of individual methods of estimation of a company value as well as value of corporeal parts of property and it deals with development of legislation of this section before accession of a strategic partner to telecommunications. The monograph elucidates to the reader external and internal sources of financing. Other part deals with the tax system and techniques of tax settlement in telecommunications sphere as well as chosen problems of an optimal tax burden. The essential part of financing is the topic of financial planning as a part of company and strategic planning. A separate chapter is devoted to budgeting as a tool for financial managing of a company. A significant part of the monograph uses financial analysis especially financial ratio indexes in postal and telecommunication companies. The publication is written for internal and external students of Žilina University, PhD-students, scientific staff dealing with questions of finances and financial management. The monograph includes particularities of post and telecommunications influencing management of these infrastructure sectors.





FACULTY OF MECHANICAL ENGINEERING

FACULTY OF MECHANICAL ENGINEERING

Veľký diel, 010 26 Žilina, Slovak Republic
Homepage: <http://fstroj.utc.sk>, E-mail: dsjf@fstroj.utc.sk
Phone: +421-41-5132501, Fax: +421-41-5652940

Dean's office:

Dean - Prof. Ing. Peter Zvolenský, PhD.
Phone: +421-41-5132500 (2559),
E-mail: zvolensky@kosz.utc.sk

Vice-Deans:

Study affairs - Assoc. Prof. Ing. Stanislav Turek, PhD.
Phone: +421-41-5132751 (2652)
E-mail: stanislav_turek@dsjf.utc.sk

Scientific affairs and foreign contacts - Prof. Dr. Ing. Ivan Kuric
Phone: +421-41-5132807 (2510)
E-mail: ivan_kuric@kma.utc.sk

Unique Activities of Mechanical Engineering Faculty in the Slovak Republic

The Faculty of Mechanical Engineering, University of Žilina, carries out its activities in the environment of other Slovak faculties based on mechanical and production engineering.

The Faculty deals with standard disciplines (such as measurement, automation, industrial engineering, technological engineering, mechanic and strength, design and machine elements) and with specific engineering disciplines (such as machinery maintenance engineering; railway vehicles; engines and lifting equipment; heat and hydraulic machines). The specific engineering disciplines are unique for Slovak faculties. Transport technology and transport engineering are characteristic for the Faculty.

The Faculty solves at present a great number of institutional tasks and projects given by the Ministry of Educational (GAV commission). The faculty is also involved in international research teams in framework of international projects such as COPERNICUS, CEEPUS, TEMPUS and Austria-Slovakia cooperation, NATO, 5th FP EU. Extent and number of projects is characteristic only for faculties with good experienced teachers and scientific staff.

Our faculty is also involved in the 5th Framework Programme of EU. This gives very considerable status among other Slovak faculties.

The geographic location of Žilina is suitable for cooperation with foreign universities near the border (so-called border collaboration). Another unique feature of the Faculty is its participation in the Fraun-



hofer Society (Germany). The first branch office of the Fraunhofer Society within Central European Countries was established by a professor from our faculty.

The great number of solved projects for engineering enterprises is also typical feature of the faculty. This is a very good way to obtain additional funding for educational and scientific process in the faculty.

Other areas such as number of students, quality control system, interest in study, international collaboration are comparable with other faculties in the Slovak Republic.

Study at the Mechanical Engineering Faculty, University of Žilina

The Faculty is accredited to educate students in a number of study fields of mechanical engineering. There are more than 1,400 students at the Faculty in daily courses, 45 PhD. daily students and 120 PhD. students studying externally.

The Mechanical Engineering Faculty of the University of Žilina, offers a university technical education and its graduates are experts who are able to solve complicated technical problems with respect to social, ethical, economic, ecological and cultural areas.

The Faculty has the following forms of study:

Bachelor Study Programme (Bc.) / 2 study fields/

- Technology of mechanical engineering
- Environmental technique

Master Study Programme (Ing.) / 7 study fields/

- Applied mechanics
- Transport and manipulation technique
- Material Engineering
- Management of industrial engineering
- Technology of mechanical engineering
- Environmental technique
- Device, regulation and automation technique

Doctoral Study Program (PhD.) / 7 scientific fields/

- Applied mechanics
- Machine elements and mechanisms

- Transport and manipulation technique
- Management of industrial engineering
- Material engineering
- Technology of mechanical engineering
- Environmental technique

Research and scientific areas of Manufacturing Engineering Faculty

The main research interests of Faculty of Mechanical Engineering are especially in the following topical areas:

- Development of science for **transport means, mobile working machines, lifting, handling, and power devices design** is orientated to improvement of a transportation system technical basis, including machines for transport infrastructure building and repairing and material handling in transport, industry, power industry, civil engineering, forestry and so on. This process is determined by the goal of reaching a high level of transport means and working machines, drives, lifting, manipulation, power and ecological devices and so on.
- Development of science for **maintenance and operating of transport** together with development of transportation systems in Slovakia and its integration to transportation system of Euro-Asia. The activity of faculty is orientated to improvement of systems for operation and maintenance of transport means and devices connected with conventional and non-conventional approaches to transport system, to safety of the system and environment.
- Development of science on **design materials and manufacturing technologies** connected with development of technical basis of transport means, machines, tools and constructions. The material and technology theories are orientated to improvement of technical basis services. The current methods for evaluating of technological and functional features are developed.
- Development of **enterprise management, manufacturing, manufacturing machines, transport and handling equipment** including the integrated enterprise philosophy. This process is orientated to production systems design, decision processes design, marketing, modelling and simulation, products quality control while respecting the specific features of human beings, nature and economics. The computer systems are a basis for the control systems in production, transportation machines and equipment, devices, automation and control technology in engineering practice..

The research units solve at present 29 institutional tasks and 19 scientific grant tasks given by the GAV SR (Scientific Grant Agency of the Ministry of Education of the Slovak Republic and Slovak Academy of Sciences). The faculty cooperates with various foreign universities from Austria, France, Germany, Hungary, Italy, the Netherlands, Poland, UK, Russia, Slovenia, etc., mainly under the scheme of programmes such as 5th FP EU, Copernicus, Ceepus, Tempus, Leonardo, Socrates, NATO as well as the Austria-Slovakia Action.

Departments

Head of Department / Contact /Research activities

Department of Materials Engineering

Prof. Ing. Peter Palček, CSc.

Phone: +421-41-5132600

E-mail: kmi@fstroj.utc.sk

Homepage: <http://fstroj.utc.sk/~kmi/ahome.htm>

- Structural analysis of all materials types
- Light metallography microscopy
- Scanning electron microscopy
- Color metallography
- Threshold states of materials,
- Fatigue properties especially at high-frequency loading (20 kHz)
- Creep tests of materials,
- Measurement of internal friction

Department of Technological Engineering

Prof. Ing. Gustav Sládek, PhD.

Phone: +421-41-5132750

E-mail: [kti@fstroj.utc.sk](mailto:kmi@fstroj.utc.sk)

Homepage: <http://fstroj.utc.sk/~kti/indexan.html>

- Technology of shaping by chip removal
- Cutting process
- Quality of machined surface and geometrical precision, engineering metrology
- Construction of manufacturing machines, cutting tools and fixtures
- Test of cutting tools
- Casting production and heat treatment, casting alloys
- Welding and forming
- Resistance welding and plastometry
- Investment casting

Department of Measurement and Automation

Assoc. Prof. Ing. Fedor Kallay, PhD.

Phone: +421-41-5132800

E-mail: kma@fstroj.utc.sk

Homepage: <http://fstroj.utc.sk/~kma>

- Computer Aided (CA) systems
- CAD/CAM, CAPP, integration
- Flexible manufacturing systems
- Robots
- Numerically controlled production of machines and transportation devices
- Measurement and diagnostics
- Regulation and automation technique
- Electrical techniques and electronic design,
- Testing and control system

Department of Industrial Engineering

Assoc. Prof. Felicita Chromjaková, PhD.

Phone: +421-41-5132701

E-mail: kpi@fstroj.utc.sk

Homepage: http://fstroj.utc.sk/~kpi/_kpi.htm

- Quality assurance and quality cost estimation
- Product and production systems
- Simulation tools in production activity control
- Modelling of production planning and control activities
- Computer aided design of production systems
- TPC - Total Production Control- new concept for simultaneous design, planning, control and improvement of production systems
- Analysis and work measurement in production processes and systems

- Productivity analysis, ergonomics
- Project management
- Cost optimisation and financial analysis

Department of Design and Machine Elements

Prof. Ing. Štefan Medvecký, PhD.

Phone: +421-41-5132900

E-mail: kkcs@fstroj.utc.sk

Homepage: <http://fstroj.utc.sk/kkcs>

- CAD/CAE systems and applications
- Virtual prototyping, visualization, photorealistic projection
- Experimental measurements and testing
- New machine units and assemblies development
- Expert statements (systematic and random break-downs of the machine units and elements)
- Friction nodes design and analysis including the experimental testing
- International standard ISO and EN application consulting

Department of Railway Vehicles, Engines and Lifting Equipment

Assoc. Prof. Ing. Daniel Kalinčák, PhD.

Phone: +421-41-5132650

E-mail: kkvmz@fstroj.utc.sk

Homepage: <http://fstroj.utc.sk/kkvmz/en.html>

- Safety of rail vehicles running and safety against derailment
- Theory and design of rail vehicles track maintenance machines, and technical means for combined transport
- Computer modelling and design optimisation
- Reliability and service life of mechanical parts of vehicles
- Theoretical and experimental research of railway wheels and mechanical parts of vehicles brake systems
- Railway vehicle dynamics
- Emission formation, combustion and engine operation with impact on the environment
- Fluid flow simulation (CFD) and combustion simulation in piston and jet combustion engines
- Problems related to dynamics of combustion engines
- Design of engines and equipment with special attention to transport and handling machinery

Department of Machinery Maintenance Engineering

Assoc. Prof. Ing. Juraj Grenčík, PhD.

Phone: +421-41-5132554

E-mail: kosz@fstroj.utc.sk

Homepage: <http://fstroj.utc.sk/kosz/>

- Maintenance processes in industrial plants, maintenance technology
- Maintenance systems by use of reliability methods – methods of Reliability Centred Maintenance
- Computer aided maintenance management systems
- Project management and computer simulation

- Railway traction dynamics
- Experimental analysis of noise and vibrations
- Engineering chemistry, corrosion protection, metal coatings and paints, environmental problems

Department of Heat and Hydraulic Machines

Assoc. Prof. RNDr. Milan Malcho, PhD.

Phone: +421-41-5132850

E-mail: kths@fstroj.utc.sk

Homepage: <http://fstroj.utc.sk/kths/>

- Hydromechanics and hydraulic machines
- Hydraulic system for different industrial branches
- Design of hydraulic systems for mobile machines
- Design of piping systems and pumping stations
- Control of hydraulic elements and systems
- Mathematical modelling and design of energy saving hydraulic circuits
- Thermomechanics and heat machines
- Air conditioning and ventilation
- Flow of fluid
- Mathematical models making and measuring in heat machines

Department of Mechanics

Prof. Dr. Ing. Vladimír Kompiš, PhD.

Phone: +421-41-5132950

E-mail: kmpp@fstroj.utc.sk

Homepage: <http://fstroj.utc.sk/kmpp/>

- Computational mechanics
- FEM/BEM formulations using Trefftz polynomials
- Computational fluid dynamics and fluid-structure Interaction
- FEM computations
- Statics, kinematics and dynamics of systems of bodies
- Strength of materials
- Optimal design of mechanical systems using FEM
- Analysis and synthesis of stochastic systems
- Strength, fatigue and fracture mechanics of steel structure elements.

Department of Applied Mathematics

Assoc. Prof. RNDr. Elena Wisztova, PhD.

Phone: +421-41-5622843

E-mail: kmat@fstroj.utc.sk

Homepage: <http://fstroj.utc.sk/web//indexa.html>

- Ordinary and functional differential equations
- Graph theory,
- Algebra,
- Geometry,
- Mathematical statistics,
- Numerical analysis,
- Modernization of the teaching process of mathematics and geometry.

CORROSION RESISTANCE OF MAGNESIUM AND ITS ALLOYS

1. Introduction

Magnesium and its alloys are perspective materials on the ground of their low specific mass, high ratio strength/weight, good cast properties and machinability and wasteless utilization. Basic mechanical properties of the Mg-alloys at normal temperature are dependent on amount of alloying elements and technology of casting. Very significant property of Mg-alloys is the ability of damping of vibration. Mg and its alloys have very low value of electrochemical stability. For this reason it is inevitable to obtain knowledge about their corrosion behaviour in different environments. In this work were tested three types of Mg – alloys in different corrosion conditions, simulated possible working conditions.

2. Experimental materials

The tested alloys are Mg-alloys AZ91HP, AZ91 and AZ63HP. The experimental materials was made by casting and delivered after heat treatment marked T6 (dissolving annealing and ageing). The microstructures of tested Mg-alloys are in Fig. 1,2. Polyedric grains of the δ -phase, what is solid solution Al in Mg, are formed all alloys. The eutectic $\gamma + \delta$ is segregate in various ratio on grain boundaries. In AZ91 alloy is eutectic segregate in form chain and in AZ63HP alloy in continual form. We can watch the areas of secondary segregate γ -phase in AZ63HP alloy.

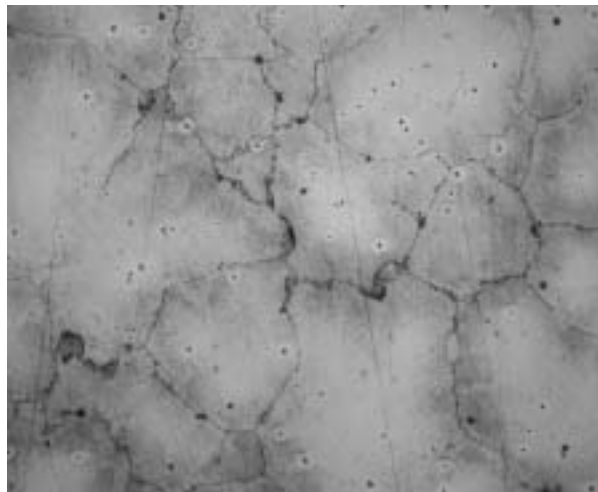

Fig.1 Microstructure of the AZ91, 100x, etch. 0,5 % Nital

3. Experiments and results

The samples of the tested material were immersed to the different environment simulated possible working conditions and after 42 days the weight losses were determined and corrosion rates calculated as it can be seen in the tab. 1.

The potentiodynamic tests were carried out in normal, distilled, river and seawater and the important characteristics of these measurements (corrosion potential, corrosion current density) were compared and are presented in tab. 2.

Corrosion rates [$\text{g}\cdot\text{cm}^{-2}\cdot\text{s}^{-1}$] of Mg-alloys in the various environments after 42 days of the test Tab. 1

Mg-alloy	River water	Normal water	Distilled water
AZ91	$1.217\cdot 10^{-9}$	$1.179\cdot 10^{-9}$	$7.785\cdot 10^{-10}$
AZ91HP	$2.251\cdot 10^{-9}$	$6.123\cdot 10^{-10}$	$7.788\cdot 10^{-10}$
AZ63HP	$9.324\cdot 10^{-10}$	$1.180\cdot 10^{-9}$	$2.643\cdot 10^{-9}$

Corrosion rates were calculated from I_{corr} according to Faraday's law at corrosion potential E_{corr} (tab. 3).

$$v_{\text{corr}} = \frac{i_{\text{corr}} \cdot M}{n \cdot F}$$

M – grammolecular weight ($24,4\text{g}\cdot\text{mol}^{-1}$), n – number of changed electrons (2), F – Faraday's constant ($9,6\cdot 10^4 \text{ C}$)

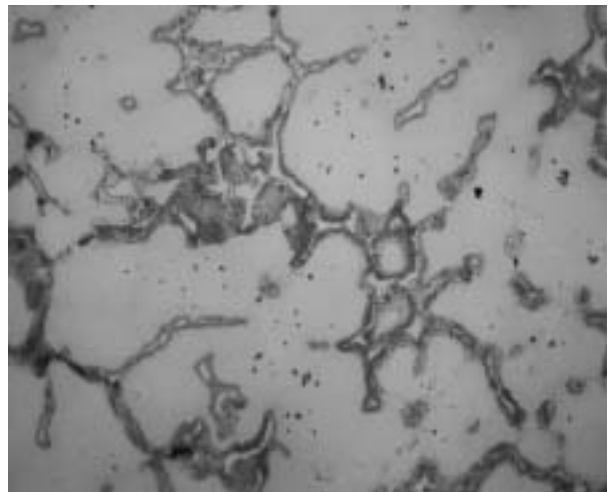

Fig.2 Microstructure of the AZ63HP, 100x, etch. 0,5 % Nital

The average values of I_{corr} [$\text{A}\cdot\text{cm}^{-2}$] and E_{corr} [V] measured potentiodynamically

Tab. 2

Environment	AZ91		AZ91HP		AZ63HP	
	I_{corr}	E_{corr}	I_{corr}	E_{corr}	I_{corr}	E_{corr}
Distilled water	$5.0600\cdot 10^{-7}$	-1.3243	$3.5507\cdot 10^{-7}$	-1.2468	$2.5933\cdot 10^{-7}$	-1.3305
Normal water	$1.1509\cdot 10^{-5}$	-1.4847	$1.2346\cdot 10^{-5}$	-1.4480	$2.2800\cdot 10^{-5}$	-1.4620
River water	$1.3877\cdot 10^{-5}$	-1.4473	$1.4560\cdot 10^{-5}$	-1.4233	$1.8910\cdot 10^{-5}$	-1.4540
Seawater	$2.0097\cdot 10^{-4}$	-1.5245	$1.9547\cdot 10^{-4}$	-1.5260	$9.5330\cdot 10^{-5}$	-1.5390

Corrosion rates v_{corr} [$\text{g}\cdot\text{cm}^{-2}\cdot\text{s}^{-1}$] at corrosion potential E_{corr}

Tab. 3

Environment	AZ91	AZ91HP	AZ63HP
Distilled water	$6.43\cdot 10^{-11}$	$4.51\cdot 10^{-11}$	$3.30\cdot 10^{-11}$
Normal water	$1.46\cdot 10^{-9}$	$1.57\cdot 10^{-9}$	$2.90\cdot 10^{-9}$
River water	$1.76\cdot 10^{-9}$	$1.85\cdot 10^{-9}$	$2.40\cdot 10^{-9}$
Seawater	$2.55\cdot 10^{-8}$	$2.48\cdot 10^{-8}$	$1.21\cdot 10^{-8}$

4. Conclusions

The corrosion attack is different between AZ91 alloy and AZ63HP alloy in distilled water. The reasons for it are structural differences between alloys. The corrosion products on the surface of γ phase are on magnesium base (MgO , $\text{Mg}(\text{OH})_2$) and they do not feature stability in distilled water. This layer breaks very easily. The anodic reactions are in the posts of film failure and the cathodes reactions are at the surface of corrosion products. The chemical composition of corrosion product is different on the surface of γ -phase ($(\text{MgAl}_x)\text{O}_y$, $(\text{Al,Mg})_m(\text{OH})_n$). The guard film (MgO , $\text{Mg}(\text{OH})_2$) is broken by these products. The reason for structural components drop out of γ -phase is galvanic corrosion on the

surface of AZ63HP alloy. The mechanisms of corrosion in normal and river water are the same. On the surface of specimens different products are formed (on the base of chemical composition of water) which can reduce or accelerate corrosion. By comparing results in river and normal water with those in distilled water we can see that corrosion rates are increasing in AZ91HP alloy and decreasing in AZ63HP alloy. The corrosion rate at AZ91HP alloy in river water was very high. The results from previous experiments showed that least resistance in industrial atmosphere have the AZ63HP alloys. This is conformable with results from the tests in river water, because river water was from industrial zone.

We measured the most positive corrosion potential in distilled water at all three alloys by potentiodynamic tests. Corrosion potentials were decreased in river and normal water and most negative potentials were in simulated seawater. The highest corrosion current occurred in simulated seawater in case of all three alloys. Aggressive chlorides in seawater create corrosion holes, increased active surfaces and corrosion rates are increased, too. Potentiodynamic tests indicate behaviour of magnesium alloys at the beginning of immersing tests. Potentiodynamic tests cannot record structural changes, which are created during long time immersing tests. Corrosion products are being created during immersing tests. They can increase or decrease corrosion rates.

Milan Sága

CONTRIBUTION TO THE SOLUTION OF ELASTIC-PLASTIC PROBLEMS

1. Description of the mathematical model

Considering ideal elastic-plastic material ($E_T = 0$) for one-dimensional cases, we can write

$$\begin{aligned} \sigma + B \cdot \|\sigma\|^{n-2} \cdot |\sigma \cdot \dot{\epsilon}| \cdot \sigma + \\ + C \cdot \|\sigma\|^{n-2} \cdot \sigma \cdot \dot{\epsilon} \cdot \sigma = A \cdot \dot{\epsilon}, \end{aligned} \quad (1)$$

where σ is the axial stress and ϵ is the total strain. The hardening effect is achieved by combination of Bouc - Wen's model with Suzuki - Minai's model, which is

$$\begin{aligned} \sigma &= \alpha \cdot E \cdot \epsilon + (1 - \alpha) \cdot z, \\ \dot{z} &= E \cdot \dot{\epsilon} - \frac{E}{2 \cdot \sigma_y^n} \cdot |z|^{n-1} \cdot |\dot{\epsilon}| \cdot z + \frac{E}{2 \cdot \sigma_y^n} \cdot |z|^n \dot{\epsilon}, \end{aligned} \quad (2)$$

where $\alpha = \frac{E_T}{E}$, z is the stress parameter and σ_y is the yield limit.

The program NONDYN for the solution of the mentioned problem was created in the programming language MATLAB. For the solution of non-linear differential equations it is modified by the Crank-Nicolson method to suit our own problem.

Let's solve a simple spatial triple truss (see Fig. 1) excited by harmonic force F .

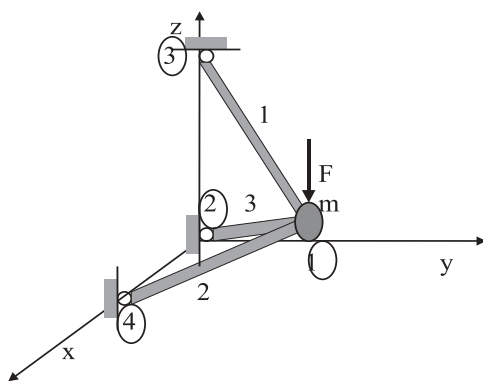

Fig. 1 FE 3-D model

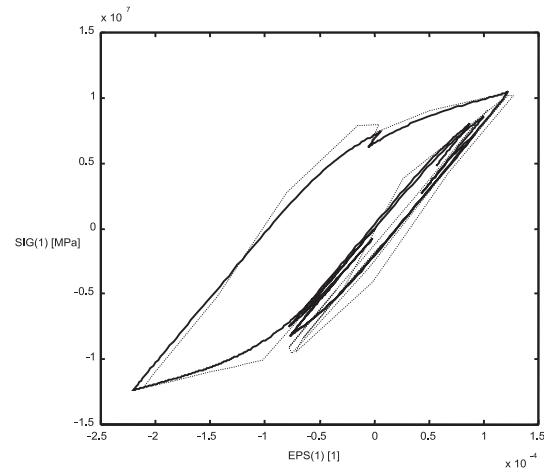

Fig. 2 Stress - strain relationship of the first element

2. References

- [1] SÁGA, M., GERMAN, R., GALČÍK, R.: *Solution of elastic-plastic problems in structural engineering*, NMCM 2000, Liptovský Ján, Slovak Republic (CD)

The paper was supported by the VEGA grant Nr. 1/7416/20

Vladimír Stuchlý – Peter Zvolenský – Juraj Grenčík – Roman Poprocký

RELIABILITY CENTRED MAINTENANCE AS A BASE FOR MAINTENANCE SYSTEM ON ŽSR

1. Introduction

In the existing system of railway vehicles periodic repairs carried out in accordance with the valid railway repair regulations, the main indicator for locomotives is the so-called mileage run, for wagons it is a time period. This approach is given by a long historical evolution and in principle by traditional way of using the planned-preventive system. Most of locomotive and wagon depots on ŽSR are defending their existence especially by carrying out all maintenance work. This is often done without real requirements and own technological possibilities on low technical and quality level, but it seems to be cost-effective comparing with price set by railway repair workshops.

Growing importance of maintenance is caused by operational-economical and technological influences. Besides, there are numer-

ous other environmental, health and safety requirements that are expected from maintenance. Growing complexity of production and service systems raises high demands on skills of maintenance workers.

2. Railway vehicles maintenance and maintenance organisation on ŽSR

Organisation of railway vehicle maintenance is being carried out in accordance with ŽSR regulation V25 "Regulations for repairs of electric and diesel locomotives" that underwent long evolution. Principal changes were done in 1967, 1975, 1982 and 1999.

Already in the first version of V25 regulation there is a definition: "A purpose of locomotive maintenance is to remove effects

of wear on vehicle components and preventively create conditions for failure-free operation between planned inspections and repairs. Basis of maintenance system is based on preventive planned inspections and repairs carried thoroughly and early enough, by which effects of wear are removed and conditions for failure-free and economic operation and for decreasing volume of repairing work are created”.

Maintenance of locomotives was basically divided into the following principal elements:

- a) Vehicle servicing in operation,
- b) Periodical inspections and repairs of vehicles,
- c) Unplanned repairs of vehicles.

Preventive maintenance system is based on the principle that periodical inspections and repairs should be carried out in such extent and quality, *so that to ensure failure-free, safe and economical operation between individual inspections and repairs while keeping given performance norm*. So they must be carried out in such an extent and in such quality so that the vehicles work economically in operation between two overhaul repairs as well as between repairs at a lower level.

That means that repair works at lower levels should remove effects of partial wear of vehicle components. Overhaul repairs should be done in such extent so that total vehicle wear would not exceed permitted operational limits.

It is interesting to follow trends in mileage norms for some locomotive series:

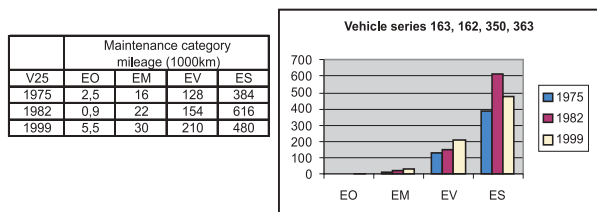

From the analysis it is evident that either already in 1975 the mileage norms were proposed so optimally that there was no need to make any changes, or there were not sufficient data needed for making changes.

The same trends could be observed also in case of passenger and freight wagons while there are efforts to change periodicity from time periods to mileage as it is in case of locomotives.

3. Maintenance information systems

ŽSR must search for new maintenance strategy. One of possible approaches, besides use of new methods (TPM and RCM) is

introduction of suitable maintenance information system for transport means and other facilities.

The Department of machinery maintenance engineering already in the 80-ties had worked out methods for implementation of reliability into the design of maintenance system. But later on we turned to the method of reliability centred maintenance – RCM, as it comprises the proper combination of statistic, historical and a-priori reliability (FMEA, FMECA and FTA).

Maintenance information system should assist in optimisation of extent and content of maintenance activities. In other words – maintenance information system should “force” a company to think about change of maintenance system and gradually focus attention to failure consequences and not to executing planned extent of maintenance works. When a company starts to think about implementation of maintenance information system, the competent managers should first of all think about goals they want to achieve by such a great change in a company. From goals, stated by competent managers, who have sufficient power, authority and ability to pursue new ideas, a project of implementation of new maintenance system should be done.

4. Tasks to be solved for improvement of railway vehicle maintenance

At present ŽSR are in the transformation process, which affects also maintenance system of rolling stock. The basic requirement is to create an effective maintenance system at minimum costs but to ensure high availability of vehicles. The transformation should bring increased reliability by adopting new maintenance system and advanced maintenance management system. This will be based on:

- analysis of needed vehicles in future in accordance with traffic volumes,
- analysis of vehicle parameters and costs for their operation (LCC)
- analysis of role of depots
- determination of structure, functions and activities carried out in depots,
- assessment of work effectiveness carried in depots and outside (outsourcing),
- maintenance costs in depots, their structure, types,
- methodology for making regulations,
- assessment of technological base (existing and required/useless machines and equipment),
- human resources – organisation, work description,
- information flows – analysis of necessary information, information systems,
- assessment of optimum number of railway depots under new situation, analysis of repair and maintenance technological level.

THE DEVELOPMENT OF TRAINING ROBOT SLR 1500

1. Introduction

The design of the robot SLR 1500 is angular. It has five degrees of freedom, three of them serve to position the end effector in the space and the remaining two determine its orientation with respect to the object being manipulated.



Fig. 1. The robot simulation

2. The control system and simulation software

The development was oriented on the design of simulation program equipment of robot, computer simulation possibilities – simulation of robot functions, motion and manipulation functions: graphic model of robot (mathematical 3D model, determination of edge visibility, kinematics bindings), the design of simulation algorithms, design of software and verification of correct function. The output of program: it is the control program for the SLR 1500 robot, which may be saved on a disk and inserted into memory again later.

3. Conclusion

The robot presents a complicated mechatronic system with several subsystems. In this time the development is oriented to the robot control system design with applying the artificial intelligence methods, mainly digital image processing and cognitive sensor systems.



FACULTY OF ELECTRICAL ENGINEERING

FACULTY OF ELECTRICAL ENGINEERING

Veľký diel, 010 26 Žilina, Slovak Republic
Homepage: <http://fel.utc.sk>, E-mail: dekan@fel.utc.sk
Phone: +421-41-5132051, Fax: +421-41-5131515

Dean - Assoc. Prof. Ján Michalík, PhD.
Vice-dean for Education - Assoc. Prof. Milan Trunkvalter, PhD.
Vice-dean for Research - Prof. Peter Bury, PhD.
Vice-dean for Development and International Co-operation
- Prof. Branislav Dobrucký, PhD.
Faculty's registrar - Ferdinand Choluj, M.Sc.

1. Introduction

The Faculty of Electrical Engineering was founded in 1953 as one of three faculties of the Railway College in Prague, and was re-established during restructuralization changes in 1992. At present the process of faculty development still continues and some new branches of educational, research and technological development complete the traditional educational orientations, namely: information technologies, power electronic systems and modern methods of electric networks control. The interdisciplinary branches as for example mechatronics, telecommunication management and biomedicine are also in progress.

Scientific-research activity is in the centre of attention of the Faculty apart from the educational activities, of course, as its development is a necessary prerequisite of the future development of the Faculty and is closely related with the quality of education. The most important forms of projects are international scientific projects and projects supported by the Scientific Grant Agency of the Ministry of Education (VEGA and KEGA projects). Institutional projects can also be important for the participation in domestic or international grant projects. A special attention is given to the co-operation with companies in the field of applied research that is very important from more points of view.

Scientific-research activity is carried out especially in the form of projects and its orientation is specified by activities within scientific-research activities of individual departments. The main results obtained during last five years are summarized in the following parts.

2. Profile and Structure of the Faculty of Electrical Engineering

2.1 Profile of the Faculty

The Faculty of Electrical Engineering originates back to 1992 after separation of the former Faculty of Mechanical and Electrical



Engineering. The departments representing the basis of the faculty have existed for some decades. They continuously created through their activities the main trend of the Faculty both in educational and scientific-research areas. Former activities of the departments were oriented mainly on technical aspects of classical transport and later tasks of communications in the form of technical operation of telecommunications increased.

At present the traditional activities are enriched with some changes characteristic for the development of science and technology in recent period. It involves especially areas of information systems, modern telecommunication technologies, development of power semiconductive systems and modern control of electric networks. The new interdisciplinary branches are also created, namely: mechatronics, telecommunication management, biomedicine engineering and specialization oriented on information systems in electroenergetics.

In the field of electric traction and energetics, the most important problem seems to be a task related to the modern traction drives for all kind of transport, then the system of modern methods of their control, supplying electric traction equipment with emphasis on their back influences on electric power systems. In the field of electroenergy the main emphasis is laid on control of electric power system, transmission and distribution of electric energy and electro-energetic feed of railways. In the area of problems connected with electric drives, the main emphasis is laid on study of new drives structures with new power factors and new kinds of their control; field of power electronic is developed.

The field of telecommunications, which has developed separately at the Department of telecommunication since 1967, is mainly oriented to questions of network and signals, numeric and impulse technology, transmitting and connecting systems, telecommunication networks, in recent years modern field of optoelectronics, digital connecting and transmitting systems, systems of data transmission, radio networks and digital signal processing have developed. In the future the main priority is going to be in the field of broadband networks. In the field of radio communication, it is the area of broadband of solid services, land and satellite mobile and radio networks. Next are optical communication systems.

In the field of control and information systems, the activity is mainly oriented to problems of increasing safety and efficiency of transmitting information within automation system of control of trans-

port, modernisation of safety facilities. Fields of safety and reliable transmission and processing of information as branches of information technologies are considered good prospects for future.

In the field of physics, except teaching basic physics, the main emphasis is laid on experimental control of elementary measurement of physical parameters, study of relevant physical phenomenon and methods of interpretation of experiments. Scientific work is oriented to study of facilities of condensed matters by acoustic and optical methods. Acoustooptical and acoustoelectrical phenomena, critical phenomena and phenomena at interfaces receive much attention, too. Study of wave fields and study in field of elementary particles are parallelly developed.

In the field of theoretical and applied electrical engineering, except teaching theoretical electrical engineering and electric measurement, scientific and technical activities are oriented mainly to optimisation of diagnostic systems in transport and diagnostic of electric traction machines. For some years the staff of the department have been solving problems of non-destructive investigation of electromagnetic and biomedical systems. From newer trends it is necessary to mention some questions from electromagnetic compatibility at chosen electrotechnic facilities, as well as some topics from mechatronics. The newest developed activity at the department is interdisciplinary Biomedical Engineering realized in cooperation with Jesenius Medical Faculty of Comenius University in Martin.

In the field of electronics and electrotechnology, the technical activity is oriented to the monitoring of quality and reliability of electronic components, materials and systems, control of quality and reliability according to IEC norms, application of programmable logical arrays, reconfiguring of circuits considering to computers, as well as diagnostic and analyses of failures and destructive analysis.

The mentioned profile orientations determine also theoretical basis offered by the departments. These also extend their offer of scientific subjects in certain study fields. Except teaching, all employees pay attention to scientific-research activity on basic level and also applied research.

The mission of the Faculty of Electrical Engineering is to provide the highest possible quality of education, training, research and consultancy, in order to meet the needs of individuals, communities and enterprises. The Faculty offers a wide range of courses in electrical engineering, from Bachelor degree courses and Master degree courses to Doctoral postgraduate courses, all of them full-time and part-time.

The accreditation commission – consultative body of the Government of the Slovak Republic carried out accreditation at the Faculty of Electrical Engineering on December 12, 2000 and according to presented materials and verification of facts, the Accreditation commission suggested and the Ministry of Education of the Slovak Republic consequently admitted the right for the Faculty of Electrical Engineering to perform the state final examination in three study subjects of bachelor study and four study subjects of engineering study. The Faculty also received the right to offer doctoral (PhD.) study, dissertation examinations and award an academic degree PhD. in five scientific fields.

The new harmonisation of study plans among faculties with related study programmes of internal regulations of the faculty (the Statute of Faculty, the Study and Exam Regulations, the Organisation Regulations, the Regulations of the Faculty Academic Senate, the Discussion Regulations of Scientific Board, general obligatory regulations) were prepared in 2002.

The Faculty of Electrical Engineering at the University of Žilina in Žilina has at present time the following competences:

1. to perform state final examinations in these study fields:
 - bachelor studies
 - Mechatronics
 - Telecommunication management
 - Electroenergetic engineering
 - engineering studies
 - Information and safety systems
 - Telecommunications
 - Electroenergetic and electrical engineering
 - with the following specializations:
 - Electric Traction
 - Electric Power Systems (Electro – energetics)
 - Electric Drives
 - Power Electronics
 - Biomedical engineering

2. to offer doctoral (PhD.) study, dissertation examinations and award scientific-academic degrees in the scientific fields:
 - 11-22-9 Physics of Condensed Matter and Acoustics
 - 26-02-9 Theoretical Electrical Engineering
 - 26-27-9 Telecommunications
 - 26-32-9 Electrical Engineering
 - with these specializations:
 - Power Electronics
 - Electric Machines and Apparatus
 - Electric Drives
 - Electric Traction
 - 38-01-9 Automation and Control
 - with specialization:
 - Process Control

2.2 Structure of the Faculty

Composition and structure of the Faculty was again reevaluated in recent years according to the analysis of difficult tasks especially in pedagogic and scientific fields. The Faculty of Electrical Engineering (FEE) has six regular departments and one associated department established in September 2002, namely:

- Department of Physics (DPH)**
- Department of Electronics and Electrotechnology (DEE)**
- Department of Theoretical and Applied Electrical Engineering (DTAEE)**
- Department of Power Electrical Systems (DPES)**
- Department of Control and Information Systems (DCIS)**
- Department of Telecommunications (DT)**
- Associated Department in Liptovský Mikuláš (AD-LM)**

The number of academic staff at the individual departments of the Faculty resulted from the analysis of educational and research activities and the number of academic staff positions at the departments is summarised in the following graph:

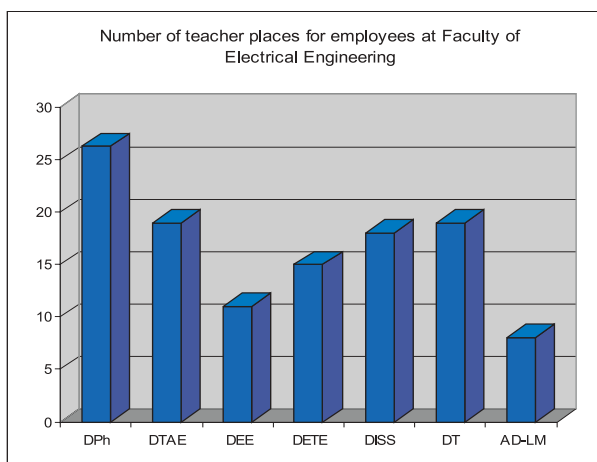

The academic staff is actively engaged in a wide range of research programmes funded by the government, industry or the Faculty of Electrical Engineering. Some departments are involved in projects of EU programmes, such as Leonardo da Vinci, SOCRATES, COST, COPERNICUS and 5FP. The Faculty of Electrical Engineering is well equipped with some special laboratories. These include mainly the following:

- Physics Principles Laboratories
- Acoustic Laboratory
- Optical Laboratory
- Electrical Principles and Electrical Measurements Laboratories
- Electronics Laboratories
- Telecommunications Laboratories
- Power Electronics Laboratory
- Electrical Machines Laboratories
- Discrete Control Engineering Laboratory
- Electrical Drives Laboratories
- Electric Power System Laboratory
- Electronics and Robotics Research Laboratory
- ISDN Laboratory
- Computer Control Laboratory
- Workstation with Graphicstation and Simulation Laboratory
- PC Classroom Laboratory
- HV - Electric Substation Laboratory
- PLC Controllers Laboratory
- Laboratory of Biomedical Engineering
- Laboratory of Image Processing and Analysis

The Faculty of Electrical Engineering has a wide range of high quality industrial scale computing facilities and sophisticated PC, UNIX-based software on the latest specifications, including CAD and E-CAD systems, simulation programmes, PSPICE based Design Lab Development, Programming System, CAD Design and Simulation Tools with PCB Layout, MATLAB with MAPLE, FUZZY and Neural

Network Toolboxes, SNNS Neural software package, MS Windows for Workgroups and MS Office Package and many others. The laboratory and computer facilities still require substantial upgrading. Several improvement projects have been completed or are under way. Some of the laboratories listed above have been equipped under the scheme of TEMPUS projects, the others under the co-operation with enterprises, or European partners, e.g. Deutsche TELECOM (ISDN Laboratory), ABB HV Technologies, etc.

2.3 Advances in Electrical and Electronic Engineering

The first issue of the *Advances in Electrical and Electronic Engineering* that was established by the Faculty of Electrical Engineering of the University of Žilina in cooperation with the Faculty of Mechatronics of the Alexander Dubček University in Trenčín was edited towards the end of 2002 as a scientific journal. The publishing of the journal creates a new opportunity for the latest scientific and research findings in the area of electrical engineering and electronics and also provides conditions for a closer cooperation among domestic institutions of similar orientation and in the future also international ones.

The journal will serve as a means of presentation of new results of research and science mainly in the areas such as energetics, power systems, information and communication technologies, safety systems, automation and control systems, mechatronics, electromagnetic theory and applications, applied physics and biomedical engineering. The journal will also provide opportunity for progressive industrial application presentations.

The establishment of the new journal will provide also the space for young science and research workers to present results obtained in both basic and applied research that should be subjected to critical evaluations. The journal will inform on awarded PhD degrees after a successful defence of the thesis.

We believe that the journal *Advances of Electrical and Electronic Engineering* will be an additional and permanently utilized source of the latest findings in the area of electrical and electronic engineering both for publishers and readers.

2.4 Development and Results in Scientific-Research Field of Faculty of Electrical Engineering

Scientific research is the second basic activity in addition to education in the Faculty and its development is necessary for future development of the Faculty and is also closely related with quality of education. Important types of research projects are international scientific projects and projects supported by the Scientific Grant Agency of Ministry of Education (VEGA and KEGA projects). However, the institutional projects can be important preparation for the entrance to domestic or international grant projects. A special attention is given to the co-operation with companies in the field of applied research.

Scientific-research work is mostly realized through the projects and their orientation is determined by scientific-research trends followed by individual departments. The main results obtained during last five years are summarized in the following sections.

ELECTRIC DRIVES AND ELECTRIC MOTORS

Department of Power Electrical Systems

The research tasks from many branches of power electrotechnics have been solved and well developed in co-operation of DPES in the field of electric drives especially with Prof. S. J. Dodds, University of East London, School of Engineering, GB, and with Dr. Utkin, Institute of Scientific Management of Russian Academy of Science. The collaboration led to setting-up a novel AC drive control named "Forced dynamic control".

After the first simulation experiments passed, the drive was realized for induction motors with a lower power level. Good results led to the cooperation with three possible producers (EVPÚ Nová Dubnica, Slovakia, ELVIC Moscow, Russian and MTE Leigh on Sea, GB) and to asking the European commission for an INCO-Copernicus project grant. The project duration will be three years with the target to develop novel kinds of electric drives for industry applications as well as the hybrid simulator for drives testing. Prof. Dodds was appointed the main coordinator and Prof. Vittek was the vice-coordinator.

In the frame of the UCODRIVE project the developed control algorithm was successfully applied to a synchronous drive. The original constant-torque first-order dynamics was improved to the second-order dynamics with the variable motor revolutions acceleration. The collaboration on the national level brought very good relations between EVPÚ and the University. A hybrid simulator with 3-phases nominal power inverter developed by EVPÚ was transferred to the University where the DPES completed it by a universal drive control system inclusive software. The task was continuously solved in the frame of the Slovak project grant VEGA. The synchronous motor vector control was extended by forced dynamics and a new synchronous reluctance drive control including forced dynamics was developed. A new application of the control methods for locomotive auxiliary drives was found in the frame of this research. [1-9].

Regarding electric machines, the research is focused to the parameters and performance investigation of the modern electronically-commutated electric machines such as PM brushless machines, switched reluctance machines, step machines, synchronous reluctance machines and inverter-fed induction machines. Excellent results were achieved with reluctance synchronous machines by creating a method for the new axial-laminated rotor design based on an analytical description of electro-magnetic field. A new rotor was constructed according to this method, which during work with the original stator shows improved characteristics – namely the output power, efficiency and power factor. A detailed analysis and properties examination of one type of the switched reluctance machine and its industry and electric traction applications is in progress. A great attention is given to parameters deter-

mination of converter-fed induction machines used for control parameters designation by deterministic and stochastic on-line and off-line methods. [1-16]

References

- [1] VITTEK, J., DODDS, S. J.: *Robust Cascade Forced Dynamics Control of Shaft Sensorless Synchronous Motor Drives*. Proceedings of the Third International Symposium "ELECTROMOTION'99", July 1999, Patras, Greece, Vol. 1., pp. 447-452 (in English)
- [2] VITTEK, J., ALTUS, J., DODDS, S. J., PERRYMAN R.: *Induction Motors Electric Drives with Forced Dynamics*. Proceedings of the Second IASTED Conference, "Control and Applications", July 1999, Banff, Canada, pp. 177-182 (in English)
- [3] VITTEK, J., ALTUS, J., BUDAY, J., MIKLO, J.: *Mrac Improves Performance of Induction Motor Drive with Forced Dynamics* Proceedings of "IASTED" Conference, "Intelligent Control and Systems", Oct. 1999, Santa Barbara, California (in English)
- [4] VITEK, J., ALTUS, J., DODDS, S. J. and PERRYMAN R.: *'Sliding Mode based outer Control OOP for Sensorless Speed Control of Permanent Magnet Synchronous Motor'* Proceedings of "8th IEEE MED" International Symposium on "Control and Automation", July 2000, Patras, Greece, CD-Rom.
- [5] VITTEK, J., ALTUS, J., BUDAY, J. and MIKLO, J.: *'Outer Sliding Mode Control Loop for Induction Motor drive with Forced Dynamics'* Proceedings of "IASTED" International Conference on "Intelligent Control and Systems", August 2000, Honolulu, Hawaii, pp. 244-249. (1/4)
- [6] VITTEK, J., ALTUS, J., DODDS, S. J. and PERRYMAN, R.: *'Vector Controlled Reluctance Synchronous Motor drives with prescribed closed-loop Speed Dynamics'* Proceedings of 11th EDPE International Conference on "Electric Drives and Power Electronics", Dubrovnik, Croatia, Oct. 2000, pp. 141-146.
- [7] VITTEK, J., DODDS, S. J.: *'Near Time Optimal Position Control of Electric Drives with Reluctance Synchronous Motor'*. 'EPE 2001' 9th European Conference on 'Power Electronics and Applications', Graz, Austria, August 2001, CD Rom.
- [8] VITTEK, J.; RAPŠÍK, M.; BUDAY, J.: *Shaft Sensorless Direct Vector Control of Induction Motor*. Proceedings of the 10th International Conference EPE-PEMC '02, Sept. 2002, Cavtat - Dubrovnik, Croatia, CD Rom
- [9] VITTEK, J., BUDAY, J., MIKLO, J., POSPÍŠIL, M., VAŇKO, D.: *Experimental Previewing of the Vector Control by the Drive with Asynchronous Motor with Forced Dynamics*. Proceedings of symposium for lecturer of El. Drives "SYMEP" Liberec, June 2002, pp. 44-49 (in Slovak)

- [10] HRABOVCOVÁ, V.; LIČKO, M.; RAFAJDUS, P.; MIHOK, J.; JANOUŠEK, L.: *An Improvement of Reluctance Synchronous Motor Quality Parameters*, International Conference on Electrical Machines, 28-30 August 2000, Espoo, Finland, Helsinki University of Technology, p. 1590-1594
- [11] HRABOVCOVÁ, V., MIHOK, J., JANOUŠEK, L., RAFAJDUS, P., HUDÁK, P.: *Analytical Approach to the Magnetic Field Distribution in Axially Laminated Reluctance Synchronous Motor (RSM)*. Proceedings of 4th International Symposium on Advanced Electromechanical Motion Systems, ELECTROMOTION '01, Bologna, July 2001, Volume II, pp. 361-366 (in English).
- [12] HRABOVCOVÁ, V., MIHOK, J., JANOUŠEK, L., RAFAJDUS, P., HUDÁK, P.: *Influence of Axially Laminated Rotor Arrangement on the Saliency Ratio of the 4-Pole Reluctance Synchronous Motor*. Proceedings of International Workshop on Electrical Machines Parameters, Cluj, May 2001, pp. 1-8 (in English).
- [13] HRABOVCOVÁ, V., MIHOK, J., JANOUŠEK, L., RAFAJDUS, P., HUDÁK, P.: *Axially Laminated Rotor Design of the 2P(Poles Reluctance Synchronous Motor)*. Proceedings of 6th International Conference on Engineering of Modern Electric Systems, Oradea, May 2001, (in English).
- [14] HRABOVCOVÁ, V.; RAFAJDUS, P.; HUDÁK, P.; FRANKO, M.; MIHOK, J.: *Design Method of Reluctance Synchronous Motor with Axially Laminated Rotor*. EPE-PEMC 2002, Cavtat & Dubrovnik (Croatia), 9-11 September 2002, p. P.1-P.8
- [15] RAFAJDUS, P.; HRABOVCOVÁ, V.; HUDÁK, P.; FRANKO, M.: *Torque Optimization of Switched Reluctance Motor*. Workshop on Variable Reluctance Electrical Machines, Technical University of Cluj (RO), 17th September 2002, (proceedings in printing)
- [16] HUDÁK, P.; HRABOVCOVÁ, V.; RAFAJDUS, P.; FRANKO, M.: *Analytical Approach to the Synchronous Reactance Calculation of the Reluctance Synchronous Motor*. OWD 02', Istebna - Zalozie (PL), 19-23 October 2002, p. 283-288.

B. Dobrucký – J. Altus

POWER ELECTRONICS, ELECTRO-ENERGETICS AND ELECTRIC TRACTIONS

Department of Power Electrical Systems

In the power electronics field, the research was oriented on the power electronics and electro-energetics synergy area. Special attention was paid to the influence of semiconductor converters in electric traction on energy supply network being solved in the frame of VEGA project "The research of Active Filters". Prof. Branislav Dobrucký is responsible for this task. Physical samples of the 1-phase and 3-phases active filters were built at the University with the EVPÚ Nová Dubnica support. The co-operation with EVPÚ continues successfully so that some device prototypes work in the Slovak electricity network at present. Other activities in power electronics are oriented to power loss reduction in various converter topologies, mainly soft-switched circuits such as resonant circuits and highly-stable power supplies. A special measurement instrument ICM1.1 was designed and produced by DPES for measuring the capacitance current in the 22 kV electricity network according to the Middle Slovak Power Plants, Ltd. order. [1-8].

The research in the electro-energetics branch is focused on upgrading the electric energy quality. The DPES is the only Department in Slovakia concerning the complex problems involving the quality of electric energy supply. The DPES-staff investigates the electric energy quality parameters in nearly all-important nodes of the Slovak electric energy supply network. Another important group of tasks is done for the electricity network control. The DPES co-operated by establishing the tertiary regulation in the Slovak energy

supply network. A significant work was done for setting-up the Slovak electricity network model for the time space from 2010 to 2015 enabling the network operation computation. The results enable to evaluate the energy transit possibilities of the Slovak energy supply network as well as to optimize the network operation in this period. [9-12].

In the electric traction area, the DPES helps in rationalization and modernization of electric traction equipment. The trains/vehicles movement PC-simulations for the traction fixed installations and rolling stock design optimization are very important research activity. These simulations are also used for the automatic train leading and target braking enabling energy supply savings systems (EMU series 471 ČD). The department participates in TEŽ (Tatra's electric railway) traction vehicle modernization. Very important function of the department is creation of Slovak Technical Standards and for the EN-CENELEC/TC9X-Standards adoption into the Slovak National Standards (STN) system.

References

- [1] HAVRILA, R., DOBRUCKY, B., BALAZOVIC, P.: *Space Vector Modulated Three-Phase to Three-Phase Matrix Converter with Unity Power Factor*, EPE-PEMC 2000, Košice, Slovak Republic, September 5-7, 2000

- [2] ROCH M., CABAJ P., JANOUŠEK, L.: "Active Filters as a Tool for Electromagnetic Compatibility of Power Systems Increasing", TELESCON 2000, Dresden, Nemecko, Máj 7-11, 2000
- [3] DOBRUCKÝ, B., BALAZHOVIČ, P., FILKA, R.; ABDALMULA, M. A. R.: *Robotic Servo-System with Sensorless Measurement of Initial Position of PMSM Motor using PC&ADSP 21062 Control*. Proceedings of the conference RAAD '01, Viedeň (AT), máj 2001, s. (CD-ROM)
- [4] HAVRILA, R., DOBRUCKÝ, B., BALAZHOVIČ, P.: *Matrix Converter Synchronous Motor Drive with Controllable Power Factor*. Proceedings of the conference EPE '01, Graz (AT), august 2001, s. (CD-ROM)
- [5] DOBRUCKÝ, B., RÁČEK, V., CABAJ, P., ROCH, M., KUČERA, R.: *A new Concept of Power Active Filtering for ac Traction Power Supply*. Zborník z konferencie EPE '01, Graz (AT), august 2001, s. (CD-ROM)
- [6] DOBRUCKÝ, B.; KIM, H., RÁČEK, V.; ROCH, M.; POKORNÝ, M.: *Single-Phase Power Active Filter and Compensator using Instantaneous Reactive Power Method*. Proceedings of the international IEEE conference Power Conversion Conference IEEE-PCC '02, Vol. 1, Osaka (JP), April 2002, p. 167-171
- [7] DOBRUCKÝ B.; FILKA R.; ABDALMULA M. A. R.; HOLČEK R.: *A New Optimisation Algorithm of Position Estimation for Zero- and Low Speed Range Using Magnetic Saliency Method*. Proceedings of the European conference about power electronics and motion control EPE-PEMC '02, Dubrovnik (Croatia), Sept. 2002, (CD-ROM)
- [8] BRANICKÝ, P.; BUKVIŠ, M.; DUBOVSKÝ, M., ONDREJKOVIČ, M.; FEŇO, I.; ŠPANIK, P.: *Practical Experience won by Capacitance Currents Measurement using the Artificially Generated Disturbance Current Method*. In: Proceedings of the international conference CIREN '02 Tábor (ČR), October 2002, pp. 1-11 (in Slovak)
- [9] POKORNÝ, M., NOVÁK, M., KOUDELA, P., DIOSI, T.: *Facilities for Voltage Control in Power System*, Medzinárodná vedecká konferencia Elektroenergetika 2000, Ostrava, September 2000, pp. 117-121
- [10] POKORNÝ, M., ALTUS, J., NOVÁK, M., OTČENÁŠOVÁ, A.: *Quality of Electric Energy Deterioration Caused by Small Appliances*, Wissenschaftliche Zeitschrift der Hochschule Mittweida, Band B: Moderne Energiesysteme, No. 6/2000, ISSN 1437-7624, pp. 93-99
- [11] GRIGER, V., GRAMBLIČKA, M., NOVÁK, M., POKORNÝ, M.: *Operation, Control and Supervision of Interconnected Power System*. EDIS, Žilina, 2001, p. 236 (in Slovak)
- [12] ALTUS, J., OTČENÁŠOVÁ, A.: *Experience with Measurements of Power Systems Effects in Slovakia*. In: Proceedings of the international conference CIREN '02 Tábor (CZ), October 2002, CD-ROM (in Slovak)

J. Dúha – M. Dado – R. Jarina

COMMUNICATION TECHNOLOGIES AND SERVICES

Department of Telecommunications

1. Investigation of Optical Fibres Parameters

The determination of optical fibres parameters using mainly the intermodal interference was the goal of the two EU projects COST 241 (1996-98) and lately COST 265 (2000-2002) solved by the Department of Physics and Department of Telecommunications.

The first stage of the project COST 241: Characterisation of Advanced Fibres for the New Photonic Network (prof. Dado – representative of SR) was oriented on measurements of transmission function and absorbance of Erbium doped optical fibres. The results were presented at COST 241 workshops in Aarhus (1996) and Budapest (1997)

Next stage, the project COST 265 (2000-2002): Measurement Techniques for Active and Passive Fibres to support Future Telecommunications, (prof. Dado – representative of SR) was pointed to measurements of cut-off wavelength, core symmetry and core diameter of optical fibres. The presented results enable to specify more

accurately measurement methods of optical fibres parameters. [1-7].

2. New Multimedia Technologies and Services

A research on new multimedia technologies at the DT is carried out in three directions.

The first direction presents research on network architecture and services for Interactive Information Systems focused on Cable Television (CaTV) [36-38]. Another direction presents an application of advanced multimedia networks to Security and Information systems [8-12]. The research incorporates also speech recognition tasks for interactive dialogue systems. A new method of speech analysis based on modulation cepstrum was successfully applied to robust isolated word recognition [13].

The third direction is an ongoing research in multimodal semantic analysis, audio-content based analysis and recognition of multimedia content [14].

Innovation of radiocommunication networks infrastructure was solved both within a national project and two EU funded TEMPUS projects. Methods of dynamic and hybrid channel allocation both to increase network capacity and reduced interference were investigated [43-45]. Information Process Management and Optimisation is adapted to the processes and multipoint routing in broadband Telecommunication Networks [18-19].

3. Circuits Designs

The research carried out in co-operation with the Czech Technical University (ČVUT) in Prague is supported by the Czech Grant Agency. The research is pointed to development of optimum-design methods suitable for modern analog circuits. They are realized in the form of mixed-mode switch-current circuits, where analog and digital parts are integrated together. A novel high-efficiency algorithm based on differential evolution algorithms was proposed [20-22]. This non-conventional solution provides better performance by suggestive decrease of the absolute influence of circuit elements and simplification of circuit structure in comparison to the conventional design methods. Recently, the research was extended by a design of the analog wave ARC filters that are derived from a wave description of the LC-prototype [23].

4. New Trends in Teaching Innovation at DT

An international cooperation and participation in the EU Tempus projects has strong influence on innovation and modernization of teaching as well as research facilities at DT. Two EU projects are worth mentioning: TEMPUS-TELECOMNET (1996-98) and TEMPUS-TELEEDUCA (1999-2001). The first one was solved by the Department of Telecommunication in the University of Žilina jointly with other two Slovak Universities (STU Bratislava - project coordinator, TU Košice) and UPC Barcelona and Politecnico di Torino. Research activities incorporate digital signal processing, telecommunication networks and services. Results were presented at the Tempus workshops (Barcelona, Bratislava, Smolenice) e.g. [13, 16]. A fund from the project helped to purchase and upgrade computing and laboratory equipment (image and audio processing, optical and radio transmission, ISDN, etc.). A support of Deutsche Telecom in building an ISDN laboratory is highly acknowledged. Very recently, the ISDN laboratory was extended by switching system S12 that was supplied by Alcatel Slovakia.

The project TEMPUS-TELEEDUCA was oriented to distance education and e-learning of employees of Slovak Telecom and the Department of Home Affairs of SR. The education institutions mentioned above together with Slovak Telecom and the Department of Home Affairs of SR participated in the project. A form of the study was chosen to utilize new information technologies. Web-based electronic study materials available via Internet and on CDs, were developed. More than 900 people have taken the courses that were developed within the project.

The DT also partially participated (together with FMI) in the following Int. projects: COST 239 (1996-98): Ultra-High Capacity

Optical Transmission Network, and COPERNICUS: High-speed Communication System Support. WDM solution for optical transport networks was introduced in [24-25].

References

- [1] KÁČIK, D., TUREK, I.: *Vyšetrovanie symetričnosti jadra optického vlákna pomocou merania offset kriviek*, *Jemná mechanika a optika*, 2002, pp. 244.
- [2] TUREK, I., KÁČIK, D., ČERNICKÝ, J.: *Vplyv ohybu na prenosovú funkciu optických vlákien a ich hraničnú vlnovú dĺžku*, *Jemná mechanika a optika*, 2001, pp. 227.
- [3] TUREK, I., MARTINČEK, I., DADO, M., ČERNICKÝ, S., *Interferencia vidov ako detektor homogenity optických vlákien*, *JMO* 7-8/1999.
- [4] DADO, M., TUREK, I., ŠTELINA, J., BITTERER, L., TUREK, S., GROLMUS, E., STIBOR, P.: *Sections from Optics for Technics* (in Slovak), EDIS Žilina, 1998
- [5] TUREK, I., MARTINČEK, I., STRÁNSKY, R.: *Interference of modes in optical fibers*, *Optical Engineering*, 39 (2000), str. 1304.
- [6] MARTINČEK, I., TUREK, I., DADO, M., GRONDŽÁK, K., ČERNICKÝ S., *Mode Interference in Optical Fibres*, *Komunikácie/Communications* 2/2000, pp. 4.
- [7] DADO, M., DROZDOVÁ, M.: *Using the NGN Service in e-commerce*, *International Symposium on Telecommunications - VITEL 2002*, 13.-14.May 2002, Portoroz, p.
- [8] VOLNER, R., BOREŠ, P., TICHÁ, D.: *CATV Architecture and Network Simulation*, *Proc. of the 6th Conf. on Electronic and Microsystem Technology, BEC '98*, Oct. 1998, Tallinn, Estonia, pp. 211-214.
- [9] ŽILKA, Z., VOLNER, R.: *Proposal of Optical CATV Network for Transmission of Distributive Services*, *Proc. of the 22nd Int. Conf. TSP'99*, Brno, Sept. 1999.
- [10] VOLNER, R., BOREŠ, P., TICHÁ, D.: *Network Model ATM-Based Broadband CATV*, *Proceeding of Conference BEC 2002*, Tallin TTU, 2002, pp. 343-346
- [11] VOLNER, R.: *CATV - Interactive Security and Communication System*, *IEEE Proc of the 34th Annual Int. Carnahan Conf. On Security Technology*, Ottawa, Canada, Oct. 2000, pp. 124-136.
- [12] VOLNER, R., TICHÁ, D.: *Main Security System of the First Highway Tunnel in Slovakia*, *IEEE Proc. of the 33rd Annual Int. Carnahan Conf on Security Technology*, Oct. 1999, Madrid, Spain, pp. 398-404.
- [13] JARINA, R.: *Speech Recognition without Necessity of Time Alignment*, *Proc. of the 4th Int. Workshop - TEMPUS Telecomnet ITTW '98*, July 1998, Barcelona, Spain, pp. 131-134.
- [14] JARINA, R., O'CONNOR, N., MARLOW, S., and MURPHY, N.: *Rhythm Detection for Speech-Music Discrimination in MPEG Compressed Domain*, *Proc. of the 14th IEEE International Conference on Digital Signal Processing DSP 2002*, Santorini, Greece, July 2002, pp. 129-132.
- [15] HRUDKAY, K., DÚHA, J.: *Cellular CDMA Systems*. *Telecommunication Services as a Market support*. STU Bratislava, May 1998, Bratislava, pp. 213-217.

- [16] DÚHA, J., HRUDKAY, K., BELOPOTOČAN, P.: *GSM Network and Traffic Telematics*, Proc. of the 4th Int. Workshop - TEMPUS Telecomnet ITTW '98, July 1998, Barcelona, Spain, pp. 106-109.
- [17] DÚHA, J., HRUDKAY, K., SLOVÁK, J., and KUBA, M.: *Mobile Systems*, TEMPUS TELEEDUCA Workshop, Barcelona, Spain, 2000.
- [18] VRBA, R., OLEJ, V., BLUNÁR, K.: *Hill Climbing, Simulated Annealing and Evolution Strategies for Optimisation Multipoint Routing in Broadband Telecommunication Networks*, Proc. of the 5th Int. Conf. On Soft Computing MENDEL'99, Brno, June 1999, pp. 149-155.
- [19] OLEJ, V., VRBA, R., BLUNÁR, K.: *Optimization of Multipoint Routing in Broadband Telecommunication Networks on the Basis of Evolution Stochastic Optimization Algorithms*, Journal of Electrical Engineering, Vol. 51, No. 7-8, pp. 182-188.
- [20] MARTÍNEK, P., BOREŠ, P., and TICHÁ, D.: *A Contribution to the Design of Filters Based on a Generalized Divider*. Proc. of European Conference on Circuit Theory and Design (ECCTD '97), Vol. 2. Technical University of Budapest, 1997, pp. 573-577.
- [21] TICHÁ, D., MARTÍNEK, P.: *Biquad Based on a Generalized Divider Structure*. Proc. of ECCTD '99, Torino, Italy 1999, pp. 229-232.
- [22] TICHÁ, D., MARTÍNEK, P.: *Biquad Based on a Generalized Divider Structure*. RADIOENGINEERING, vol. 11, no. 2, 2002, pp.18-25.
- [23] MARTÍNEK, P., TICHÁ, D., and VORLÍČEK, J.: *Switched-Current Analog Wave Filter*. RADIOELEKTRONIKA 2002 (CD-ROM). Bratislava. SUT, Faculty of Civil Engineering, 2002, vol. 1, pp. 1-4.
- [24] SLOVÁK, J., VACULÍK, M.: *The Use of the WDM Technique in Optical Transport and Access Networks*. Proc. of BEC 2000, Tallinn, Estonia, Oct. 2000, pp. 327-332.
- [25] SLOVÁK, J., VACULÍK, M.: *IP over WDM - the New Philosophy of the Optical Transport Networks*, Proc. of the 23rd Int. Conf. TSP 2000, Brno, Sept. 2000, pp. 41-44.

J. Zahradník – K. Rástočný – J. Spalek – M. Balážovičová

INFORMATION AND CONTROL – RELATED SYSTEMS ANALYSIS

Department of Control and Information Systems

1. Introduction

Research activities of the Department of Control and Information Systems (DCIS) are oriented to the sphere of information and safety-related system analysis and synthesis from theoretical models solving to answering the current short-term projects of operation including their implementation. There are many sectors of activities in which the DISS has exclusive position in the Slovak Republic, especially in expertise processing in the field of analysis and synthesis of railway interlocking systems.

The sphere of reliable and safe information transmission in control of selected critical processes both in safety-related systems for all kinds of transport, complex technologies and in security systems for protection of humans and property provides dynamic incentive for all the staff. Realisation of information services for operative control supported by automation and computer technology is critical in decisive branches of the national economy.

In research and scientific projects the DCIS co-operates in a long term with partners abroad, especially with the Technical University in Budapest (Hungary), the Technical University in Braunschweig (Germany), companies such as: Scheidt & Bachmann GmbH (Germany), AŽD Prague, s.r.o. (Czech Republic), SIEMENS Building technologies (Switzerland), etc.

2. Risk analysis and modelling of the control and transmission systems safety properties

Transitions of control systems for safety-related critical processes to a new technological level require the application of sets of models, which allow for the exact risk execution at critical process controlling and execution of the safety indicators of the control, information and transmission systems. The control task with fixed-end is set so that the integral criterion of the optimality is the value of the expectable risk at fixed value of effectiveness. The outputs of the modelling are comparable with the results of the present methods based on experiential principles. These kinds of models could be used in analysis and synthesis problems [1-7].

3. Formalisation and modelling of the control systems functional properties

The use of new technologies is accompanied with increasing the complexity of designed hardware and software solutions. Systems complexity and functional safety requirements call out a necessity of new approaches to functional requirements specifications. In this field, formal methods based on mathematical modelling, formal logic and graphical notations are applied. One of the perspective and well-known graphical notation is an object-oriented unified modelling language - UML. This language provides a wide range

of means (diagrams) for writing formalised function requirements specifications. In connection with some of standard formal methods UML-based specifications of control systems can be subject to formal verifications, too [8-10].

4. Artificial Intelligence Elements in Control of Critical Processes

Both basic and applied research in this field is oriented to the theory and taxonomy of the critical processes, their position in technological and manufacturing processes (both control and controlled) regarding the risk being used. The results of scientific and research activities in this area were verified by modelling and dynamic systems simulation in discrete state space in MATLAB – Simulink – Fuzzy Logic Toolbox environment. It is indicated, that using selected tools of artificial intelligence permits refining of the safety-related critical process controlling with quantified credibility value of the input variables and modification of the elementary control functions according to the present risk level of the given process [11-14].

References

- [1] KONČELÍK, V.; ŠOLTÝS, V.: *Procesorově řízený bezpečný odpojovač drenážních ochran úložných zařízení. Nová železniční technika č. 4/1999. ÚVAR Brno, s. 118-123. ISSN 1210-3942.*
- [2] KRBILOVÁ, I., RUSNÁK, P., TOMAŠOV, P.: *Information Protection in Flow Control Systems. Magyar távközlés, March (1999), pp. 40-41.*
- [3] MUZIKÁŘOVÁ, L.; FRANEKOVÁ, M.: *Digital Track Circuit Receiver Based on the Cross-Correlation Analysis – 33rd Spring International Conference Modelling and Simulation of Systems, MOSIS '99, Rožnov pod Radhoštěm, 27-29. 4. 1999, s. 209-216.*
- [4] RÁSTOČNÝ, K.: *Model for Safety Analysis of the Interlocking System. 3rd International scientific conference ELEKTRO '99, May 25 - 26, 1999 Žilina. Zborník s. 13-18. ISBN 80-7100-602-5.*
- [5] RÁSTOČNÝ, K.; ZAHRADNÍK, J.: *Relation Between Structure of an Interlocking System and Test Diagnostics Requirements. Periodica polytechnica ser. transp. eng. vol. 27, NO. 1-2. PP. 29-41 (1999) Univerzita Budapešť. ISSN 0303-7800.*
- [6] TOMAŠOV, P.: *Information Theory. Monografia, EDIS ŽU, Žilina, 1999, s. 256*
- [7] TOMAŠOV, P.; RÁSTOČNÝ, K.; ZAHRADNÍK, J.: *Parts of Model of Information and Safety Systems. Vedecký časopis Komunikácie č. 2/2000. ŽU v Žiline, s. 23-29. ISSN 1335-4265.*
- [8] JANOTA, A.; RÁSTOČNÝ, K.; ZAHRADNÍK, J.: *The Use of UML in Design of Railway Interlocking Systems. International scientific conference. The transport of the 21st century. Warszawa - Polska, 19-21.9.2001, s. 93-100.*
- [9] JANOTA, A.; RÁSTOČNÝ, K.; ZAHRADNÍK, J.: *UML a Formal Method Usable in Development of Safety-Related Systems. CSTIT 2001, Proceedings of the International Workshop on Computer Science and Information Technologies, Ufa, Russia, September 21-26, 2001, s. 194-198. ISBN 5-86911-342-3.*
- [10] RÁSTOČNÝ, K.; ZAHRADNÍK, J.; JANOTA, A.: *An Objekt Oriented Model of Railway safety-Related Control System. Vedecký časopis Komunikácie č. 4/2002. ŽU v Žiline, s. 32-39. ISSN 1335-4265.*
- [11] BALAŽOVIČOVÁ, M.: *Hypotheses Evaluation about the State of the Critical Processes. On-line Journal of Slovak Society for Cybernetics and Informatics, August 2002.*
- [12] FRANEKOVÁ, M.: *Simulation of Systems with a Digital Modulator/Demodulator in the MATLAB Environment. Chip 10 (2002). s. 170-172*
- [13] MOLNÁROVÁ, M., SPALEK, J.: *Fuzzy Monitoring of the Safety-Related Critical Processes. Časopis Híradástechnika 2001/9, HTE Budapest, s. 21-24, HU ISSN 0018 2028.*
- [14] SPALEK, J., MOLNÁROVÁ, M.: *The Use of Fuzzy Logic in Control of Safety-Critical Processes. Komunikácie 1, Scientific Letters of the University of Žilina, (1999). s. 13-17. ISSN 1335-4265.*

S. Kmeť – J. Čuntala – M. Hrianka

SYSTEM AND TECHNICAL APPROACHES TO QUALITY MANAGEMENT IN ELECTRICAL INDUSTRY

Department of Electronics and Electrotechnology

The aim of the research project solved in the department of electronics and electrical technology of the Faculty of Electrical Engineering since 1999 is a scientific contribution to providing and improving quality of products and services mainly in electrical

small and medium- sized enterprises. Quality of products and services even in electrical engineering is an important tool for competitiveness, exporting, increasing national economy effectiveness and improving life quality of our population. Development of sci-

entific knowledge of quality gives rise to such fundamental transformations in well-developed economies the access of which is changed fundamentally. Science orientated to quality management changes the structure of production force, perfects working means and technical-organizational changes connected with them, including the changes in qualification and organization of companies.

The PHARE project titled "Total Quality Management" was the point of departure to educative activities of our teachers in twenty electrical firms where the principles of total quality management - TQM were explained and practised in a progressive way to the extent of 56 hours in each company.

International collaboration in the given sphere was realized successfully within the framework of the Leonardo da Vinci project. Two workshops were arranged at the University of Zilina in the framework of the project. The experts from schools and industry of five West European countries took part in the workshops. The result of the project was significant from the viewpoint of common approach to the increasing performance of firms in the European area. The result was drawn up in collaboration also with the Slovak electrical firms, which applied the results. The evaluation of quality and reliability of the high voltage equipment produced conditions to realise the testing stand that was built in collaboration with Stredoslovenska Energetika a.s. Zilina. The grant KEGA being solved at the present is a continuing application of the achieved results in the field of university educational system by introducing the Quality Management Systems at the faculties of electrical engineering.

In the framework of the VEGA grant, which is coordinated by the Slovak Technical University Bratislava, the technical aspects of evaluating and increasing quality of microelectronic systems are elaborated further on. The researchers, under the management of assistant Professor PhD. Miroslav Hrianka, achieved significant results in image analysis, which are applicable in the biomedicine as well. [1-2]

Realization of the achieved results in the sphere of quality management consists mainly in creation and improvement of Quality Management Systems in SME, in the sphere of education of managers and auditors and in consultation activities for some companies. Practical realization of the achieved research results is particularly significant for standardization, metrology, safety and dependability, environment as well as for the preparation of experts for area of quality management in companies of electrical industry.

The titles as Total Quality Management, Quality Management in the Sector of Services, Providing and Improving Quality, Corporate Quality Management can be found among the publications issued for economic sector, and in one breath they are also the titles of textbooks. The details about Collaboration of the department in the area of quality management with companies and another universities can be found on the web-site www.kvalita.sk.

The research in the field of microelectronics in the Department of Electronics and Electrotechnology is oriented to applica-

tion of perspective programmable logic devices. One of the most significant project presents the small intelligent graphical microcomputer (Fig. 1). The heart of the microcomputer is built on a signal processor and programmable logic device. The electronic system was created by connection of two different architectures, microcomputer on one side and programmable device on the other side. This system gains high flexibility because its features can be adapted by reprogramming not only on structural but also on procedural level [3].



Fig. 1. IGC unit - view from component side

The Department of Electronics and Electrotechnology in the frame of the Universities programmes can use the access to the last CAE development means for Field Programmable Gate Arrays design provided by the world leaders producers - companies Xilinx and Altera. In this field of semi customize devices design we have worked out the joint projects of LON interface circuit design in an association with the company Datatherm s.r.o. as well as the semi customize communication module of optical network designed with company Elteco a.s.

The main goal of the team of Department is to continue the study and research in the field of programmable logic devices and their software implementations of reconfigurable applications in the branch of telecommunications and control systems.

References:

- [1] HRIANKA, M.: *Spatio-Temporal Thermal Analysis of Electronic Systems*, Proc. International Conference Applied Electronics 2002, West Czech University in Pilsen, pp. 93-96
- [2] HRIANKA, M., SLUSARČÍK, M.: *Quality Transmission of Additional Image Information by 2D Image Basis*, Proc. International Workshop IFAC, Programmable Devices and Systems Technical University Ostrava, February 11-13, 2003
- [3] ČUNTALA, J., CHUDÝ, A., URBAN, J.: *Small Graphical Controller Unit, PDS 2000 IFAC Workshop on Programmable Devices and Systems*, VŠB-Technical University of Ostrava, Czech Republic, February 8, 9 2000, pp. 173-177.

DIAGNOSTICS AND NON-DESTRUCTIVE TESTING

Department of Theoretical and Applied Electrical Engineering

1. Diagnostics Methods for some Electronics Equipment

The research project, whose main aim is to create a computer controlled open measurement system for continual insulation state monitoring of transformer, was solved. The attribute “open system” represents a possibility of the system adaptation for more type devices or measured quantities and outputs interpretation according to measured device. The priority in this case is to find relation between specific device parameters evolution and insulation state of device.

The transformer diagnostic system was developed in collaboration with the company Lambda Control s.r.o Liptovský Hradok. This diagnostic system (Fig. 1) can serve both for transformer producers and services. It is successfully installed in Calibration and Transformer Repair Company in Hlohovec ZSE, g.e. [1-7].



Fig. 1 The Transformer Diagnostic System

2. Non-Destructive Investigation in Electrical and Biomedical Applications

Within the framework of several projects solved at the Department of Theoretical and Applied Electrical Engineering two main problems were investigated. The first issue was connected with non-destructive testing of materials and especially with the electromagnetic acoustic transducer (EMAT) utilised for materials characteristics investigation. Especially the elastic anisotropy and defects position in the anisotropic aluminium sample and in t GaAs sample with thin metal layer were evaluated. Except the ultrasonic testing methods the electromagnetic non-destructive evaluation of conductive materials by eddy current testing was developed. The obtained results were published e.g. in [8-10]

The second investigated problem was in the field of biomedical applications where modelling and simulation of physiological dynamic systems by analogous electromagnetic characteristics were performed. The results and recommendations for computer aided non-invasive diagnostics for cardiovascular system were discussed [11-12].

Within the VEGA project “Monitoring, Processing and Modelling of Electric Signals of Biological Objects” the system for monitoring electric signals of biological objects on the basis of streamlined electronic parts was created, necessary set of sensors for monitoring electric signals of biological objects and possibilities of exploitation of new principle to obtain electric signals of biological objects were analysed. [13-14]

The problem of remote insulation state measurement of electrical machines was solved and the new measurement system was developed and verified [15-16]. This system under a test went in EVPU Nova Dubnica and was installed in Duslo Šafa Inc.

In the field of non-destructive detection of insulating degradation in power network and antenna systems the thermo-vision camera is used at the DTAE. Within the frame of the research project the camera is utilized for visualization and quantification of thermal effects, e.g. uncovered diagnostics, control and monitoring of product processes. Recently the thermo-vision technology has been used also for biomedical application [17-18].

Research activity established on EMC monitoring is also electromagnetic field detection and quantification of its influence on biological subjects. Electromagnetic field levels in control rooms for very high voltage power network and its influence on attendant staff were investigated and obtained results were evaluated according to valid STN, as well as the influence of mobile phones on human body was measured [19].

3. Design of Transport Vehicle Products

The research and development of the principles of synergy effect on mechatronical approach to the design of transport vehicles products applying CA. technologies in virtual reality design methods and development of cognitive unit of mechatronical system for software complete locomotive control were carried out, too.

The research and development of sophisticated diesel electric locomotives (DEL) – Virtual Reality Design (methodology and application, no-conversion data flow in design of products, Rapid

Prototyping Technology application in mechatronical concept, distance concurrent engineering in products development, etc.), progressive testing methodology of DEL and tuning software of DEL, modularisation and unification of locomotives parts and units (power-pack, complete locomotive control units for wide range of locomotive power, research and development of sophisticated no-barrier light vehicle railcar based on e-transport concept, transfer of technological knowledge to methodology of automotive products development, etc.), were the results of other projects oriented on mechatronics [20].

References:

- [1] MICHALÍK, J., GUTTEN, M., BEŇOVÁ, M., ŠIMKO, M., ŠEBOK, M.: *Control of the Hour Angle by Direct Current*. Technical Journal for Electrical and Power Engineering, 2, 2001, pp. 26–27.
- [2] GUTTEN, M., MICHALÍK, J.: *Method of Verifying of Short Circuit Currents Influences on Power Transformer Windings*. Advances in Electrical and Electronic Engineering, No1-2, Vol. 1, 2002, pp. 28–32.
- [3] MICHALÍK, J., GUTTEN, M.: *Review of Diagnostics and Measurements of Transformers*. Proceedings of 4th International Conference: New Trends in Diagnostics and Repairs of Electric Machines and Equipments, Žilina, 2002, pp. 215–218.
- [4] KUČERA, S., MICHALÍK, J., BOROŠKA, J.: *Hybride Untertagebergbaulokomotive und ihr Einfluss an die Arbeitsumgebung*. II. Międzynarodowa Konferencja Naukowo-techniczna „Napedy Maszyn Transportowych 98” PL, Gliwice, 1998, pp. 193–198.
- [5] KUČERA, S., MICHALÍK, J.: *Elektrische-traktion und ihr Einfluss an die Untertagebergbauumwelt*. Internationale Wissenschaftliche Konferenz Mittweida, D, 1998, pp. 143–147.
- [6] KUČERA, S., MICHALÍK, J., DOBRUCKÝ, B., MAKAROVIC, J.: *Progressive Control of Tractive Drive for Rapid Lifts*. 22th International Spring Seminar on Electronics Technology, Dresden, Germany, 1999, pp. 231–235.
- [7] MICHALÍK, J., GUTTEN, M., BEŇOVÁ, M., ZÁHORSKÝ, R.: *Diagnostic System of Transformers*. Technical Journal for Electrical and Power Engineering, CR, 2000, No 5, pp. 11–13.
- [8] ČÁPOVÁ, K., ČÁP, I.: *Material Anisotropy Investigation Using Anomalous Electromagnetic Generation of Acoustic Wave*. Electromagnetic Non-destructive Evaluation. Studies in Applied Electromagnetics and Mechanics 14, IOS Press (Elsevier), Amsterdam, 1998, pp. 74–81.
- [9] ČÁPOVÁ, K., ČÁP, I., FAKTOROVÁ, D.: *Special Problems of Electromagnetic Acoustic Transducer for Material Non-destructive Testing*. International Journal of Applied Electromagnetics and Mechanics 15, IOS Press, 2001/02, pp. 73–77.
- [10] ČÁPOVÁ, K., ČÁP, I., FAKTOROVÁ, D.: *Electromagnetics and Elastodynamics of Conducting Structures with Electromagnetic Acoustic Transducer*. Journal of Electrical Engineering, No. 9, 2002, pp. 53–56.
- [11] ČÁPOVÁ, K., BLAZEK, V., ČÁP, I., BUČKULIAKOVÁ, L.: *Physiological Fluid Systems Modelling and Visualization*. International Journal of Applied Electromagnetics and Mechanics 14, IOS Press 2001/02, pp. 377–380.
- [12] ČÁPOVÁ, K., BLAZEK, V., ČÁP, I., BUČKULIAKOVÁ, L.: *Non-linear Physiological Processes Modelling by Analogous Electromagnetic Systems*. Japanese JSAEM Studies in Applied Electromagnetics and Mechanics, 9, 2001, Japan, pp. 419–420.
- [13] NEVESELÝ, M., ŠPALDONOVÁ, D.: *Special Filters, Resonators and Oscillators with SAW*. Proceedings of the 6th conference: New Trends in Signal Processing, Liptovský Mikuláš, 2002, pp. 207–210.
- [14] ŠPALDONOVÁ, D., NEVESELÝ, M.: *Intrdigital Transducer with Slanted Fingers*. Journal of Electrical Engineering, No 53, 2002, pp. 153–157.
- [15] POLIAK, J.: *Analysis of the Influence of Commutation of Unidirectional Electric Machines on Telecommunication Devices*. Advances in Electrical and Electronic Engineering, No. 1–2, Vol. 1/2002, pp. 62–65.
- [16] POLIAK, J., VANÍK, V.: *Problematika diaľkového merania izolačného stavu elektrického stroja v zálohe*. Zborník prednášok z medzinárodnej konferencie Technická diagnostika stroja a výrobných zařízení DIAGO 2003, str. 288–291, ES VŠB-TU Ostrava, 02/2003
- [17] BOROŠKA, J., KUČERA, S., KUČERA, M.: *Possibilities of Increasing of Ecological Conditions in Mining Environment by Reconstruction of the Present Engine DH 30*. Proceedings of the International Conference, Katowice, Poland, 2002, pp. 33–37.
- [18] CHUPÁČ, M., ŠIMKO, M., ŠEBOK, M.: *Diagnostics of Antenna Systems of Radio Transmitters*. Proceedings of Conference DIAGO 2002, Ostrava, CR, pp. 230–233.
- [19] Šimko, M., Šebok, M., Chupáč, M.: *Utilization of Infrared Technology in Diagnostics*, Zborník medzinárodnej konferencie Diagon 2000, Zlín, CR.
- [20] [90] *Exhibition of DEL Code 772 – 40th International Machinery Fair in Brno (1998) (Czech Republic), 5th International Machinery Fair in Nitra 1998 (Slovak Republic)*

P. Bury – I. Jamnický

STUDY OF PHYSICAL PROPERTIES OF PERSPECTIVE MATERIALS USING ACOUSTIC METHODS

Department of Physics

Acoustical methods have been used for a long time at DPh to study physical properties of solid states. In last years the attention was oriented to the investigation of acoustoelectric and acoustooptical interaction in semiconductors and semiconductor structures to study deep centers (vacancies, on-site defects, self-interstitials, etc.) that can play an important role in both substrate materials quality and microelectronic device performance.

Recently, the acoustoelectric effect in semiconductor structures has shown to be a useful tool for the experimental study of deep centers and two basic modifications of acoustic deep-level transient spectroscopy (A-DLTS) were introduced. The former surface acoustic wave (SAW) technique uses a nonlinear acoustoelectric interaction between the SAW electric field and the free carriers in an interface region, which generates a transverse acoustoelectric signal (TAS) across the structure. Transient measurements of the rise or fall times of the resulting dc and hf part of the TAS have been used to study charged traps [1-2]. The latter longitudinal acoustic wave (LAW) technique uses an acoustoelectric response signal (ARS) observed at the interface of the semiconductor structure when a longitudinal acoustic wave propagates through the structure [2-4].

Both ARS and TAS are extremely sensitive to any changes in the space charge distribution in the interface region especially due to the trapped charge after an injection pulse has been applied. Their time development represents acoustoelectric transients, which reflect relaxation processes associated with the thermal recombination of excited carriers moving towards their equilibrium state. Using a method of computer evaluation of isothermal acoustoelectric transients by applying a data compression algorithm [5] the activation energies and corresponding capture cross-sections can be determined from transient measurements of acoustoelectric response amplitudes as a technique of A-DLTS. The technique of acoustic transient spectroscopy based on the utilization of space charge inhomogeneity in high resistivity semiconductors produced by non-uniform illumination can be used to bulk deep centers investigation, too. The space charge inhomogeneity can generate in proper conditions both the longitudinal and transversal or surface acoustic wave by applying a high frequency electric field [6]. The A-DLTS technique consists then in the analysis of the amplitude time development of such generated acoustic wave after the light is turned off and that is detected by the receiving transducer.

The principle of the A-DLTS technique as the acoustic spectroscopy technique using both SAW and LAW as well as the exper-

imental procedures based on the computer evaluation of isothermal acoustoelectric transients by applying a data compression algorithm and method of digital filtering by convolution has been applied for several kinds of semiconductor structures including Si MIS structures [1, 5], GaAs/AlGaAs heterostructures [1, 2, 8] and high resistivity semiconductors [6, 7] to determine deep center parameters and proved to be an effective method to study deep centers that can play an important role in substrate materials used for electronic devices.

Representative A-DLTS spectra of Cr-Doped high-resistivity GaAs obtained for various generated acoustic waves (fast transversal T1, slow transversal T2, longitudinal L and SAW) and illustrated in Fig. 1.

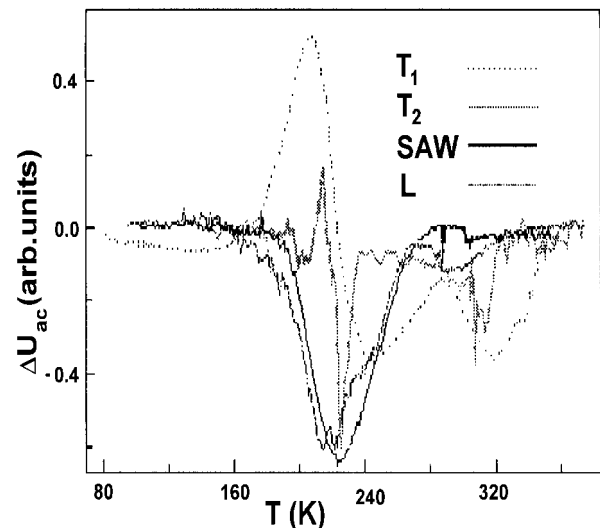

Fig. 1 A-DLTS spectra of Cr-doped GaAs obtained for various generated acoustic waves

Further attention was given to experimental study of glassy materials with the fast ion transport because they play an important role in a number of modern electrochemical devices, such as solid-state batteries, electrochromic displays, and sensors as well as for fundamental interest in their ion transport mechanisms. The ion conductive glasses have several advantages comparing with crystalline materials because of their easy preparation, their stability and the large available composition ranges.

It is known that the investigation of conductivity spectra of ionic glasses can reflect basic features of relaxation and transport mechanisms of mobile ions and the high ion conductivity at room temperature is the most important criterion which should be met by the fast ion conductive glasses. However, transport mechanisms can be investigated also by acoustic methods that can have some advantages comparing to electrical ones as the high sensitivity, absence of contact phenomena and so on.

The main purpose of acoustical investigation was to investigate ion transport mechanisms and to determine the relation between acoustical and electrical properties for various glass composition in glasses prepared in the systems CuI-CuBr-Cu₂O-M_mO_n where M_mO_n is P₂O₅ and/or MoO₃.

The experimental investigation of acoustical and electrical properties of ion conductive glasses in system CuI-CuBr-Cu₂O-(P₂O₅+MoO₃) represented by eight various samples showed an important influence of chemical composition and ion transport mechanisms and indicated more than one transport mechanism [9, 10]. The fact that activation energies determined from both electrical conductivity measurement and acoustical attenuation spectra have very similar values proved that the mechanisms can influence electrical and acoustical losses in ion conductive glasses.

References:

- [1] BURY, P., JAMNICKÝ, I.: Proc. 16th Int. Congr. on Acoustics, Vol. I, Seattle, (1998) 429.
- [2] BURY, P., JAMNICKÝ, I., RAMPTON, V. W.: Physica B 263-264 (1999) 94
- [3] BURY, P., JAMNICKÝ, I., ĎURČEK, J.: Phys. Stat. Sol. (a) 126 (1991) 151
- [4] JAMNICKÝ, I., BURY, P.: Phys. Stat. Sol. (a) 139 (1993) K35
- [5] BURY, P., JAMNICKÝ, I.: Acta Phys. Slovaca 46 (1996) 693.
- [6] BURY, P., HOCKICKO, P., JAMNICKÝ, I.: Proc. 17th Int. Congress on Acoustics, Rome, Vol. I, 2001, p. 154
- [7] BURY, P.: Proc. 16th Int. Congr. on Acoustics, Vol. I, Seattle, (1998) 431
- [8] BURY, P., HOCKICKO, P., RAMPTON, V. W.: Acta Phys. Slovaca (will be published in vol. 53, 2003).
- [9] BURY, P., JAMNICKÝ, I., JAMNICKÝ, M., HOCKICKO, P.: Proc. 17th Int. Congress on Acoustics, Rome 2001, Vol II., p. 152
- [10] BURY, P., HOCKICKO, P., JAMNICKÝ, M., JAMNICKÝ, I.: Proc. 32nd Int. Acoustical Conf. EAA Symposium, Banská Štiavnica 2002, p. 67

I. Turek – J. Štelina – C. Musil

EXAMINATION OF SELF-DIFFRACTION IN MAGNETIC FLUIDS AND PHOTOREFRACTIVE EFFECT

Department of Physics

The main attention was paid to experimental investigation of self-diffraction of two interfering Ar coherent laser beams in the samples of magnetic fluids based on water or kerosene. Using the simple description of the obtained results when the interference field creates a space periodic temperature grating by thermo-diffusion distribution of magnetic particles, good accordance with experimental results was achieved.

The time dependence of the diffracted beam intensity after the interference field is switched off informs about the diffusion process of the magnetic particle or aggregates forming the optical grating. The distribution of particles with respect to their size was determined. The self-structuralization of magnetic particles after application of homogeneous and strong illumination of magnetic fluid were observed [1-3].

The research project "Investigation of nonlinear optical and acoustooptical effects in condensed matter and fluids" involved the following issues:

1. The investigation of magnetic fluids based on single-domain particles Fe₃O₄ dispersed in kerosene or water and the temperal dyestuff dispersed in water. The experimental arrangement with Ar laser was used (Fig. 1).

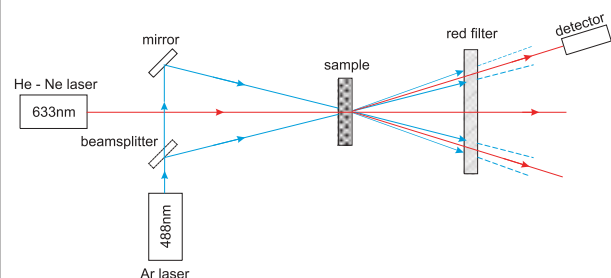

Fig. 1 Experimental set up for self-diffraction investigation.

The experiments confirm that the self-diffraction effect in samples of magnetic fluid is connected with the distribution of

colloidal particles and temperature modulation of refractive index, too. The quadratic dependence of time constant of disappearing first diffraction beam on grating constant was confirmed and its self structuralization of magnetic particles caused probably by negative Soret constant was observed.

2. The photorefractive effect was studied in LiNbO_3 . The optical field created by the interference of two coherent beams of Ar laser was recorded that arises due to the redistribution of space charge on at least two levels, which are presented in the gap.
3. The original nontraditional method of investigation of electron relaxation processes in surface electron states was made. The measurement connected with the generation of acoustic wave at the end of the depletion layer was made. The electron surface states were calculated, too [4].
4. The Si thin film and thin film doped by TiO_2 deposited on ceramic substrates were studied by X-ray profile analysis using the special program made for the separation of the diffusion and coherent scattering.

References:

- [1] TUREK, I., ŠTELINA, J., MUSIL, C., TIMKO, M., KOPČANSKÝ, P., KONARECKÁ, M., TOMČO, L.: *The effect of self-diffraction in magnetic fluids*, Jour. of Magnetism and Magnetic Materials 201 (1999) 167
- [2] FANIN, P. C., CHARLES, S. W., KOPČANSKÝ, P., TIMKO, M., OCELÍK, V., KONARECKÁ, M., TOMČO, L., TUREK, I., ŠTELINA, J., MUSIL, C.: *A comparative study of determination of ferrofluid particle size by means of rotation Brownian motion and translation Brownian motion*, Czechoslovak Journal of Physics, 51 (2001), 599–608
- [3] TUREK, I., ŠTELINA, J., MUSIL, C., KOPČANSKÝ, P., TIMKO, M., KONARECKÁ, M., POTOČOVÁ, I., JURÍKOVÁ, A., TOMČO, L.: *Self-diffraction of the light in magnetic fluids*, Czechoslovak Journal of Physics 52 (2002), Suppl. A, p. 273–276.
- [4] BRACINÍK, J., KEJST, J.: *Acoustic Technique for Study of the Surface Nonequilibrium Processes in Piezoelectric Semiconductors*, Acta Acustica, accepted for publication Nov. 10, 2002.

I. Turek

INTERMODAL INTERFERENCE IN THE OPTICAL FIBRES

Department of Physics

One of the main tasks of teamwork in the common optical laboratory of the Department of Physics and Department of Telecommunications devoted to fibre parameter is investigation of intermodal interference.

It is well known that if the wavelength of light introduced into an optical fibre is smaller than the cut-off wavelength λ_c of the LP_{11} mode, more than one mode can propagate in the fibre. The fact that these modes propagate with different phase velocities yields the effect of intermodal interference, which is manifested by adding an interference term to the signal consisting from the sum of intensities of the interfering modes.

If the signal at the end of the fibre is detected by a detector with sensitivity independent on coordinates, the interference term is zero because the eigenfunctions of interfering modes are orthogonal. But where the detection of the optical field is restricted on a matching place (Fig. 1) the interference term appears on the spectral dependence of the signal [1].

In Fig. 2 there are shown as examples spectral dependences of signals containing interference of the first and the second, and the first and the fourth modes in two different fibres. As it can be seen from the figure the characteristic “wavelength of interference

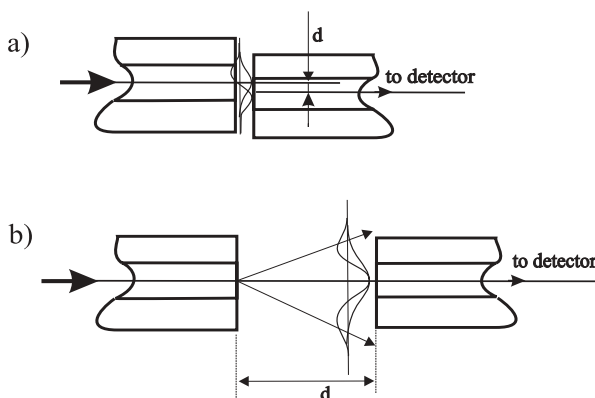

Fig. 1 The detection suitable for interference of symmetric and antisymmetric modes (a) and two symmetric modes (b)

centres” (marked as λ_{12} and λ_{14}) is different in different fibres. This fact indicates that intermodal interference can be used for diagnostic of the fibres.

Intermodal interference is very sensitive to the variation of refractive index profile. It allows one to discover changes of the

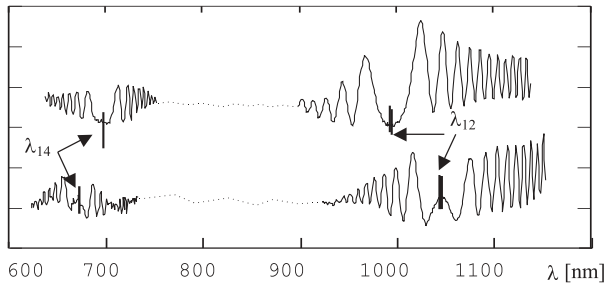

Fig. 2 The spectral dependence of signals containing interference of the first and the second and the first and the fourth modes in two different fibres

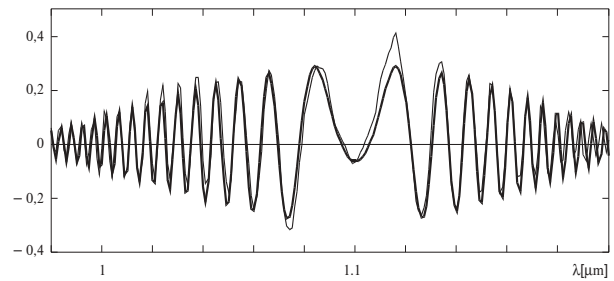

Fig. 3 Comparison of measured spectral dependence and dependence calculated assuming linear dispersion of the refractive indices

fibre parameters before a significant mutation of their customer parameters occurs [2].

A theoretical treatment showed that the ratio $L = \lambda_{12} / \lambda_{14}$ of experimentally measured values λ_{12} and λ_{14} can give an information about fibre refractive index profile [3]. Because the determination of the interference centres is not a difficult it can be used for control at the fibres fabrication. As the wavelength of the light can be measured with high precision the precise determination of periodicity of the interference term is possible. That can give another information about the fibre. The comparison of measured spectral dependence and dependence calculated assuming a linear spectral dependence of refractive index of core and cladding of the fibre (fig. 3) confirms it.

Assumption of quadratic dependence of the refractive indices can give accordance of these dependences in quite wide spectral region. The good accordance between measured and calculated curves means that the intermodal interference can be used also as a tool of dispersion determination [4].

The examples of use of the intermodal interference given in previous paragraphs do not represent all possibilities of intermodal investigation. Not either all topics of the group working in our laboratory but we hope that they illustrate results of the laboratory.

References

- [1] STIBOR, P., TUREK, I., DADO, M.: *Ověření vhodnosti transverzální offset metody pro určování parametrů optických vláken*, *Jemná mechanika a optika*, 1997, str 216.
- [2] TUREK, I., MARTINČEK, I., STRÁNSKY, R.: *Interference of modes in optical fibers*, *Optical Engineering*, 39 (2000), str. 1304.
- [3] TUREK, I., KÁČIK, D., PETERKA, P., GRONDŽÁK, K.: *Intermodal interference as a tool for optical fibre diagnostics, to be published in Recent Research in Optical Engineering*, Research Signpost, Kerala, India.
- [4] TUREK, I., KÁČIK, D., MARTINČEK, I.: *To the influence of the material dispersion on the intermodal interference in optical fibres*, To be published in *Communication*

I. Melo – M. Gintner

PHENOMENOLOGICAL STUDIES OF THE ROLE OF THE TOP QUARK IN THE STRONG ELECTROWEAK SYMMETRY BREAKING

Department of Physics

The goal of this project was to find signatures of the strong electroweak symmetry breaking at future electron-positron colliders. We namely looked for signatures of a new vector resonance ζ and a scalar resonance S in the process $e^+e^- \rightarrow \mu^+\mu^-$. We constructed Lagrangian that describes interactions of the new resonances with particles of Standard Model and found cross sections and event numbers for future e^+e^- collider working at energies above 800 GeV. We also found (in collaboration with CERN and

IEP SAS Košice) the relevant backgrounds for the signal process [1].

References:

- [1] Gintner, M., Melo, I.: *Resonances from strongly-interacting electroweak symmetry breaking sector at future e+e- colliders*, *Acta Physica Slovaca*, 51 (2001) pp. 139-149.



FACULTY OF CIVIL ENGINEERING

FACULTY OF CIVIL ENGINEERING

Komenského 52, 010 26 Žilina, Slovak Republic
Homepage: <http://svf.utc.sk>
E-mail: sekrdek@fstav.utc.sk
Phone: +421-41-7635651, 7634818
Fax: +421-41-7233502
SAO - Phone: +421-41-7635652, 7635653
SAO - Fax: +421-41-7233502

Dean: Prof. Ing. Ján Čelko, PhD.
E-mail: jcelko@fstav.utc.sk
Vice-dean: Prof. Ing. Karel Kovárik, PhD.
E-mail: kovarik@fstav.utc.sk
Vice-dean: Assoc. Prof. Ing. Libor Ižvolt, PhD.
E-mail: libori@fstav.utc.sk
Vice-dean: Assoc. Prof. Ing. Daniela Ďurčanská, PhD.
E-mail: durcan@fstav.utc.sk

The Faculty is accredited to educate students in the field of civil engineering (transport structures for construction design, reconstruction and maintenance of railway tracks, roads, highways, urban roads, bridges and tunnels). There are more than 1,000 students at the Faculty in daily courses, 27 PhD. daily students and 43 PhD. students in external form. The students from abroad can participate in both forms of study.

The Faculty solves theoretical problems of design for transport structures, modeling, strain analysis, computer-based strength calculations and traffic planning in its research and professional activities. Significant results are achieved in measuring and diagnostics of transport structures subjected to dynamic loading. Courses of study are realized in three levels: bachelor (3 years), master (2 years), PhD (3 years).

Courses of study:

Geodesy - only 1st level

Civil Engineering 1st level

- Railway Engineering 2nd level
- Roadway Engineering 2nd level
- Civil Engineering Structures 2nd level

Construction Management 1st and 2nd level

In civil engineering courses the student choose his/her master's program after finishing 1st level from the described programs. Graduates are granted a diploma in engineering and the academic degree of Engineer. The study is finished with a state final examination, and the defense of a diploma thesis.



The full-time PhD. study is organized after finishing the master's program in the following fields of study:

- Mechanics of Rigid and Flexible Bodies
- Theory and Construction of Engineering Structures
- Technology of Constructions
- Forensic Engineering.

The PhD. study is finished with a doctoral examination and presentation of a candidate's dissertation. Successful students are granted the degree of PhD.

Research Activities

More than 20 national and international research projects are being solved at the Faculty of Civil Engineering. They are concentrated to research of new types of transport constructions and to diagnosis and evaluation of existing structures under a dynamic load. The research activities are focused also on modernisation of highway network, railways and railways stations and on building constructions. Remarkable results have been achieved in the field of transport planning. Bilateral contacts of teachers of the Faculty with universities and research centres in Europe are also very intensive.

International relations and co-operation of the Civil Engineering Faculty

International relations of our faculty are now focused mainly to the participation in EU projects. As most of Slovak Universities we also participated in TEMPUS projects. These projects helped us to be acquainted with functioning of projects of the European Commission and they also broadened our contacts with European universities.

These contacts are now very useful as we participate in various scientific and mobility programmes.

The typical mobility programme is the SOCRATES-ERASMUS programme. Our faculty started with this programme in 1999 and now it serves to our students as one (and the most important) possibility to spend one semester of their study in some European university. We have very good contacts with our partners at the universities in Germany

and France, but unfortunately there are no such contacts with universities in UK. This is caused by low interest of English universities in the SOCRATES programme. Therefore our English speaking students are handicapped and frustrated. The frustration of our students is growing during the last two years because the amount of EU funding per one student is decreasing.

Another interesting part within the SOCRATES programme is the EUCEET project which is the network of European civil engineering faculties. Our faculty has participated in this project since the year 2001. The result of the project is a close co-operation with all participating faculties.

A similar EU programme LEONARDO has started at our University during this academic year. This programme supports practical stays of our students in EU factories and enterprises. We hope that the programme helps our students to deepen their practical knowledge and also their foreign language abilities.

Our university is now a co-ordinator of the programme INTRANSNET, focused on creating the network of transport research facilities in Europe and our faculty plays an important role in this project. This programme is a part of the 5th EU Framework Programme.

Besides the EU projects our faculty co-operates very closely with other civil engineering faculties, especially with the neighbour countries as e.g. the Czech Republic and Poland.

Departments of the Faculty

Department of Structural Mechanics

E-mail: kmchfstav.utc.sk

Phone: +421-41-7243343, 7635651-3

Teaching - Theoretical Mechanics, Static of Structures, Dynamics of Structures, Theory of Elasticity, Experimental Mechanics, Strength of Materials, Mechanics of Continuous Medium.

Research - Dynamics and Diagnostics of Civil Engineering Structures (Bridges, Roads, Highways and Railways), Wind Engineering, Seismicity and Environment.

Department of Geodesy

E-mail: kgdfstav.utc.sk

Phone: +421-41-7248012, 7635651-3

Teaching - Mapping, Geodesy, Cartography, Railway Geodesy, Cadastre of Real Estates, Theory of Errors, Information System of the Cadastre.

Research - Analytic Railway Projecting, Calibration of Geodetic Instruments, Vertical and Horizontal Movements, Theory of Confidence and Accuracy of Measurements.

Department of Geotechnics

E-mail: kgfstav.utc.sk

Phone: +421-41-763 56 51-3, 7643391

Teaching - Geology, Engineering Geology, Soils and Rocks Mechanics, Foundation, Underground Constructions and Tunneling, Hydraulics and Hydrology.

Research - Structural Analysis of Soils and Rocks, Mathematical Modelling (Slope Stability, Hydraulics and Ecology in Civil Engineering).

Department of Structures and Bridges

E-mail: kskmfstav.utc.sk

Phone: +421-41-7635651-3

Fax: +421-41-7241868

Teaching - Concrete Structures, Steel Structures, Concrete Bridges, Steel Bridges, Building Materials.

Research - Load Carrying Capacity of Steel and Concrete Structures and Bridges, Evaluation of Existing Bridges, Structure and Material Deterioration and their Effect on Bridge Structure Reliability, Utilisation of Composite Materials for Bridge Rehabilitation.

Department of Railway Engineering

E-mail: kzs @fstav.utc.sk

Phone: +421-41-7635651-3, 7243374

Teaching - Designing, Construction and Reconstruction of Railways, Station and Junctions, Railway Economy and Maintenance, Transport Construction Management.

Research - Design and Construction of High-Speed Railway Lines, Reconstruction of Railway Lines in Mining Areas, Railway Transport Noise.

Department of Highway Engineering

E-mail: kcsfstav.utc.sk

Phone: +421-41-7243351, 7635651-3

Fax: +421-41-7243351

Teaching - Road and Highway Design, Road Pavement, Road Maintenance, Urban Network Systems, Transport Engineering and Planning, Laboratories.

Research - Protection of Pavement against Frost, Highway Materials, New Materials for Mixtures, Pavement Evenness, Winter Maintenance, EIA.

Department of Building Engineering and Urban Planning

E-mail: kpsufstav.utc.sk

Phone: +421-41-7635651-3, 7645112

Teaching - Road and Highway Design, Road Pavement, Road Maintenance, Urban Network Systems, Transport Engineering and Planning, Laboratories.

Research - Building Heating Engineering, Building Acoustics, Environment, Physical Planning Problems and Building Law.

Department of Construction Management

E-mail: krsfstav.utc.sk

Phone: +421-41-7635651-3

Fax: +421-41-7243351

Teaching - Pavement Management System, Road Management and Economy, Civil Engineering Technology, Project Management, Laboratories.

Research - Highway Materials, New Materials and Technologies, Economy of Highway Network, Pavement Economy.

The Faculty accredited laboratories

The laboratories consist of five units.

Laboratory No. 1 is concentrated on a dynamic diagnosis of structures, bridges and structural materials. It also performs all types of prototype and conclusive tests of sleepers, means of fastening and rails.

Laboratory No. 2 performs technical diagnosis of structural constructions, bridges and materials. It also concentrates on performing loading tests of bridges.

Laboratory No. 3 carries out tests of aggregates, bituminous bonds and also a design of bituminous mixtures and controls their quality. It also performs tests of temperature conductivity of various materials. Basic properties of soils and measurements of its bearing are also performed in this laboratory.

Laboratory No. 4 concentrates on tests of bearing sleeper subsoil.

Laboratory No. 5 concentrates on tests of soils properties.

Ján Bujňák – Jaroslav Odrobiňák

BEHAVIOUR OF STEEL-CONCRETE COMPOSITE GIRDER

The rheological properties of concrete play significant role in stress redistribution through steel-concrete composite cross-section. A long-term experimental measurement of rheologic effects on continuous steel-concrete composite beam has been running during 200 days. The results were tested to both a non-linear time dependent computer aided computation and suggested a simplified approach. From this comparison it can be concluded that if shrinkage effects are separated, simplified approach is in good accordance with both the measured strains and the values obtained from ANSYS. Therefore, except for shrinkage influence, load stress prediction can be made by a simple calculation with sufficient accuracy, Fig. 1.

Composite beams, which consist of a steel girder and concrete slab, present optimal structural system with good exploitation of both materials. However, in a negative hogging region they are less effective due to concrete cracking. Slab cracking influences cross-section efficiency and durability of a whole structure.

For the purpose of experimental measurement, two physical models of composite girders were prepared. The experiment focused mainly on the formation and propagation of cracks in RC slab of composite girders under load inducing tensile stress in slab. The

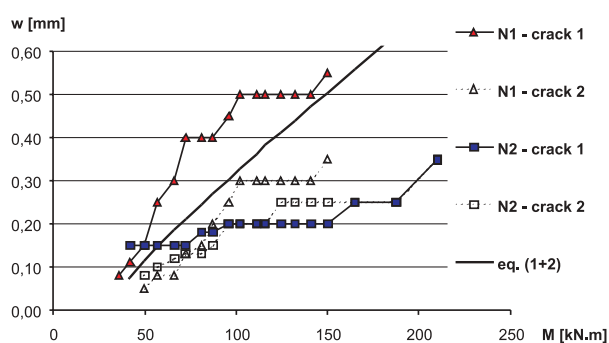

Fig. 2 Crack development and comparison with design

results showed a great influence of initial cracks in slab on crack propagation. The assumption of negligible influence of tension stiffening on the structure behaviour in the case of minimum amount of reinforcement was also confirmed. For a crack width, big variation can be clearly stated both within cracks in a slab and between each of two slabs, Fig. 2. Consequently, the prediction of a crack width and crack spacing seems to be difficult. The next step of the research would be testing a new approach (or updating

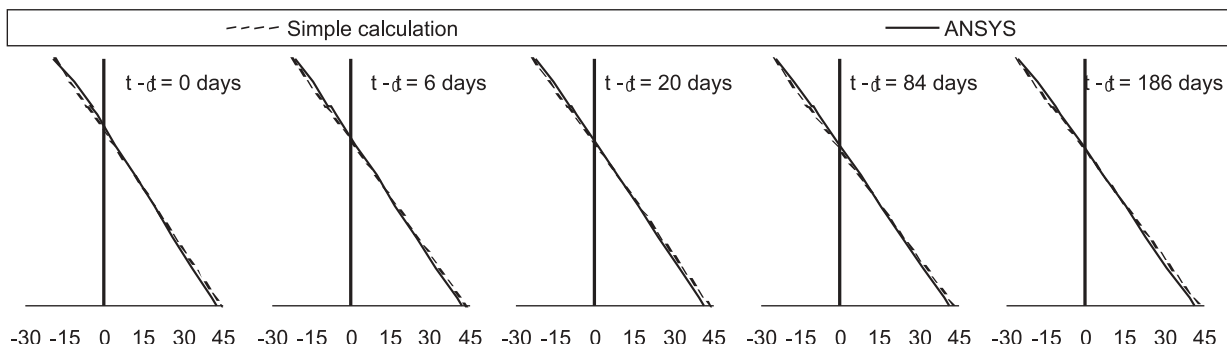

Fig. 1 Comparison of determined stresses in composite cross-section above middle support

the existing one) for prediction of a crack width and spacing in composite slabs. A comparison with a non-linear analysis in the ANSYS programme is in contemplation. Moreover, it seems to be substantial to continue the co-operation with Cracow University of Technology, where additional measurements on composite slabs affected by tension have been done.

In addition, a new progressive shear connection by perfbond strip was also studied in cooperation with this university. The dowel strength, which is very important for design of this type of shear connection, was specified on the basis of results of experimental tests.

Jana Ižvotová

CALIBRATION AS A PART OF CONTROL QUALITY SYSTEM IN SURVEYING

Implementation of quality management system into geodetic work becomes unavoidable part of assuring the quality of surveying processes in conformity with the norm ISO 9001. Because of this fact, a metrological infrastructure is built up in a geodetic laboratory to enable quality control with verifying and determining metrological characteristics of instruments used in geodetic work.

The process of metrological assurance depends on building technical facilities, verifying calibration technologies or making the new ones in conformity with required accuracy and reliability, setting up the suitable software for adjustment of a great number of results, etc. Concerning the geodetic instruments the calibration procedures consist most of all of determining the accuracy of instrument, which is represented with the standard deviation or systematic error.

Such a procedure was used in determining the periodical error of total station, which consists of comparing the measured distances with precise scale laying on the calibration basis with recording the laboratory atmospheric conditions. The presumption was to obtain the systematic error that can be found out along the wavelength of electromagnetic bearing wave as differences of measured distances and periodical curve adjusted with Fourier harmonic analysis.

Least square method and Fourier analysis used to adjust a number of measured data seem to be optimal from the point of view of statistical objectivity and accuracy. The results of the described

calibration technology involve not only a periodical systematic error that concerns mainly the electronic part of instrument, but also the value of additive constant of system instrument – prism, which have the systematic influence on measured distances, too.

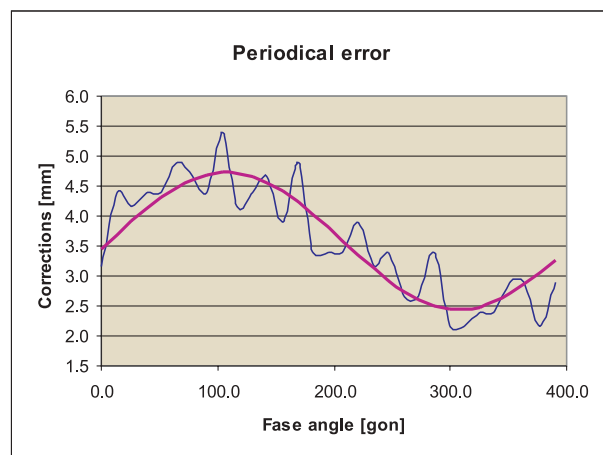

Concerning the results reached on the laboratory calibration basis till now, we can say that the technology to determine the systematic periodical error of distance instruments is reliable, in addition to the atmospheric conditions, technical support and method of statistical adjustment influence on results accuracy.

Ivan Malíček et al.

NEW CONSTRUCTIONS AND MATERIALS USED AT THE MODERNISATION OF RAILWAY TRACKS AND STATIONS AND THEIR INFLUENCE ON THE RAILWAY TRACK QUALITY

The subject of the grant project VEGA, solved during the years 2000 - 2002, was the research and verification of constructions and materials, which are designed and used in the process of modernisation of railway tracks and stations. The task was divided into 5 subtasks:

1. Construction of substructure for the optimised and modernised railway tracks
Responsible researcher: Assoc. Prof. Ing. Libor Ižvolt, PhD.
2. Verification of the construction of permanent way
Responsible researcher: Ing. Ján Špánik, PhD
3. New structural elements for turnouts on the modernised railway tracks
Responsible researcher: Ing. Mária Karabinová, PhD.
4. Railway connections and branches within the modernisation of the railway stations
Responsible researcher: Assoc. Prof. Ing. Janka Gombitová, PhD.
5. Influence of railway operation on the quality and durability of classical railway bed construction
Responsible researcher: Assoc. Prof. Ing. Milan Mikšík, PhD.

The preliminary results were, or will be, used in the area of creation of new norms and legislation, carried out by the members of the Department of Railway Engineering and Track Management, and within solution of specific problems of application research. The results were published in 44 research and scientific articles.

References:

- [1] Grant project No. 1/4148/97 Modernisation of Railway Tracks and Stations - using of new Constructions and Materials and their Influence at Track Quality.
- [2] Grant project No. 1/7409/20 New Constructions and Materials for the Modernisation of Railway Tracks and Stations and their Influence at Track Quality.



Map of modernisation of the Slovak Railways lines

Ján Špánik et al.

GEOMETRICAL POSITION AND ARRANGEMENT OF 1435 MM GAUGE RAILWAYS

A design and approval of design of the national norm STN 73 6360 Geometrical position and arrangement of 1435 mm gauge railways valid since September 1999, which specifies the basic technological parameters for designing and construction of railway tracks and stations and criteria for their control, operation and maintenance. The task for the Department of Railway Engineering and Track Management was specified by The Slovak Ministry of Transport, Posts and Telecommunications. The results were implemented by SÚTN Bratislava and in accordance with the norm the

railway tracks of 1435 mm gauge up to 160 km/h track speed are designed and operated.

The Change No1 in STN 73 6360 Geometrical position and arrangement of 1435 mm gauge railways.

In December 2002 the final proposal concerning the wording of Change No1 was submitted for the approval process, which extends the validity scope of the original norm for the 1435 mm gauge railway tracks for the speed up to 200 km/h.

Milan Mikšík – Ján Špánik

ENVIRONMENTAL ASSESSMENT OF EXHAUSTED MATERIAL FROM RAILWAY SUBGRADE

The Methodical Instruction No 18/1999 MDPaT SR, "Environmental assessment of exhausted material from railway subgrade" was published by MDPaT in co-operation with MŽP SR (Slovak Ministry of the Environment), and has been valid since September 1999. It was prepared by the members of the Department of Railway Engineering and Track Management on the base of solution of two tasks of applied research. The Methodical Instruction specifies the methodology for extraction of exhausted

material, procedure of its further processing, method and methodology of environmental assessment of that material. Nowadays on the base of that instruction the environmental quality of the railway subgrade material is being assessed before all works in which it is interfered into the subgrade as well as at the design preparation of the modernisation of the further sections of the Slovak railways network.

Janka Gombitová et al.

THE PLATFORMS ON THE RAILWAYS

Works on preparation and elaboration of the final draft, which were carried out by members of the Department of Railway Engineering and Track Management on the order of The Slovak Ministry of Transport, Posts and Telecommunications (MDPaT SR), were realised by SÚTN Bratislava that published the national

norm STN 73 4959 The Platforms on the Railways valid since December 2001. The norm specifies requirements for designing, construction and reconstruction of the platforms and related equipment of the 1435 mm gauge railway tracks up to 160 km/h track speed.

Ivan Malíček et al.

DESIGN OF RAILWAY STATIONS

The national designed norm STN 73 6310 “Design of railway stations - basic principles” stipulates principles for designing, modernisation and rebuilding of railway stations and turns-out and their equipment on the 1435 mm gauge railway tracks. The Slovak

Ministry of Transport, Posts and Telecommunications was sponsor of this task, the final realisation was provided by SÚTN Bratislava and the norm has been in force since December 2001.

Libor Ižvolt et al.

CHANGE OF THE BASIC ŽSR-S4 REGULATION RAILWAY SUBSTRUCTURE

In the Department of Railway Engineering and Track Management the following changes of annexes of this regulation were prepared:

Annex No. 7, Geotechnical exploration of the body of the substructure.

Annex No. 11, Use of the geosynthetics in the body of the substructure and in its formation.

Annex No. 12, Use of the geosynthetics in the railway subgrade.

Annex No. 20, Determination of the deformation module.

All the annexes were approved by the contractor and published as valid regulations and they determine rules for diagnostics of the construction of the railway subgrade and use of new materials at the construction and maintenance of the railway subgrade. These regulations are valid for all Slovak railway tracks and are used at the designing and maintenance works.

Verification of theoretical properties of new construction elements for the construction of railway subgrade and new materials are realised in the laboratory of the department.



Verification of deformation properties of a model construction of the railway subgrade on the large test stand of the Department of Railway Engineering and Track Management.

In the laboratory of the department there are large and small test stands enabling modelling, measurements and assessments of supposed quality of construction parts from a complex aspect in

real conditions. On the basis of positive results of assessment, further operational verification is proposed in operating conditions on the railway tracks.

Milan Mikšík et al.

TECHNOLOGICAL AND ENVIRONMENTAL CONDITIONS OF THE MATERIAL SUPPLY FOR THE RAILWAY BED CONSTRUCTION AND FOR THE RAILWAY SUBGRADE FOUNDATION LAYER

The task was solved by the staff of the Department of Railway Engineering and Track Management for the Slovak Railways. The results of the solution were realised as the company norm TNŽ 72 1514 Technological and environmental conditions of the material

supply for the railway bed construction and for the railway subgrade foundation layer, valid since July 2000 defining technical and ecological material properties of the railway subgrade construction layers.

Karol Potoček – Tomáš Potoček

ADDITIONAL WARMING OF A BUILDING FROM A POINT OF VIEW OF FINANCIAL RESOURCES EFFECTIVENESS

An important part of a building service value and necessary condition for its service is to provide thermal circumstances suitable for people staying and working inside or for technological processes carried out in the building. Current energetic situation presses users of heated buildings to decrease energy consumption for buildings' heating. The improvement of thermal-insulating properties of existing wrapping jacket of building can significantly help to fulfil this requirement.

Additional repair of wrapping jacket of building (warming) is then economically and thermal-energetically effective when during this repair will be achieved savings which equal or are higher than given financial resources for its making. It can be expressed by equations and graphically.

- a) for situations without inter-year price accumulation of energy
Fig. 1

$$K \leq \Delta m \cdot h \quad h = \frac{(1+i)^n - 1}{i(1+i)^n}$$

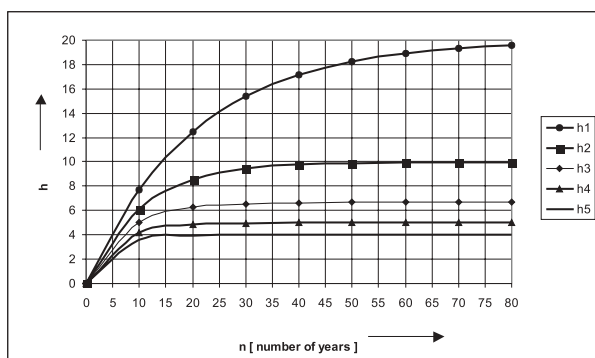

Fig. 1 Graphical illustration of the course h for different i and number of years n

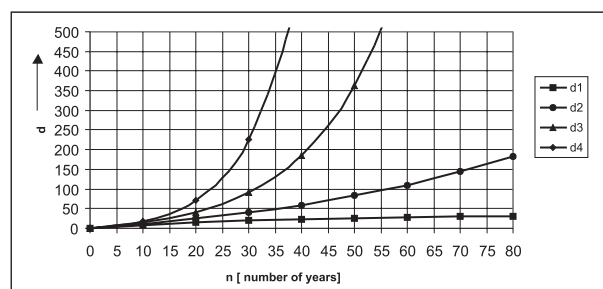

Fig. 2 Graphical illustration of the course d for i = 8% different r and number of years n

where i - discount investor rate (%), h_1 ($i_1 = 5\%$), h_2 ($i_2 = 10\%$),
 h_3 ($i_3 = 15\%$), h_4 ($i_4 = 20\%$), h_5 ($i_5 = 25\%$)
 n - number of years during which we gain annual decrease
of expenses for heating about Δm (Sk) per year

b) for situations with coefficient of yearly energy price increase
 r (%) Fig. 2

$$K \leq \Delta m \cdot d \quad d = \frac{1 + r - (1 + r) \left(\frac{1 + r}{1 + i} \right)^n}{1 - r}$$

d_1 ($r_1 = 5\%$, $i_1 = 8\%$), d_2 ($r_2 = 10\%$, $i_2 = 8\%$), d_3 ($r_3 = 15\%$,
 $i_3 = 8\%$), d_4 ($r_4 = 20\%$, $i_4 = 8\%$)

References:

- [1] POTOČEK, K. - POTOČEK, T.: *Zateplenie budovy z pohľadu efektívnosti vynaložených finančných prostriedkov*, Tepelná ochrana budov, Praha 2/2001, ISSN 1213-0907.

Karol Potoček - Tomáš Potoček

ADDITIONAL WARMING OF CIRCUMFERENTIAL WALLS OF HEATED BUILDINGS FROM WATER VAPOUR CONDENSATION POINT OF VIEW

A most serious problem for keeping circumferential wall quality and service life after its additional warming is water vapour condensation. Additional warming must be suggested so that water vapour cannot condensate in the wall. This is necessary for optimal circumferential wall service life.

In case we cannot eliminate water vapour condensation in the wall it is important to enable liquefied water vapour (which is from winter time) evaporate during summer or transient time from the wall.

This can be performed by suitable solution of wall construction. In this case relative ratio between ΣR_{d1} and ΣR_{d2} (Fig. 1) will be as follows:

$$G_K - G_V \leq 0 \quad (\text{kg} \cdot \text{m}^{-2} \cdot \text{rok}^{-1})$$

G_K - the quantity of liquefied water vapour ($\text{kg} \cdot \text{m}^{-2} \cdot \text{rok}^{-1}$)
 G_V - the quantity of evaporated water vapour ($\text{kg} \cdot \text{m}^{-2} \cdot \text{rok}^{-1}$)

Where

$$\Sigma R_{d1 \text{ required}} = n_{\text{necessary}} \cdot \Sigma R_{d2}$$

in which

$$n_{\text{necessary}} = \frac{\Delta p_{1k} - m \cdot \Delta p_{1v}}{\Delta p_{2k} - m \cdot \Delta p_{2v}}$$

and $\Sigma R_{d1} \geq \Sigma R_{d1 \text{ required}}$

The repair of circumferential wall performed by dint of this warming will reliably fit from the point of view of year humidity regime.

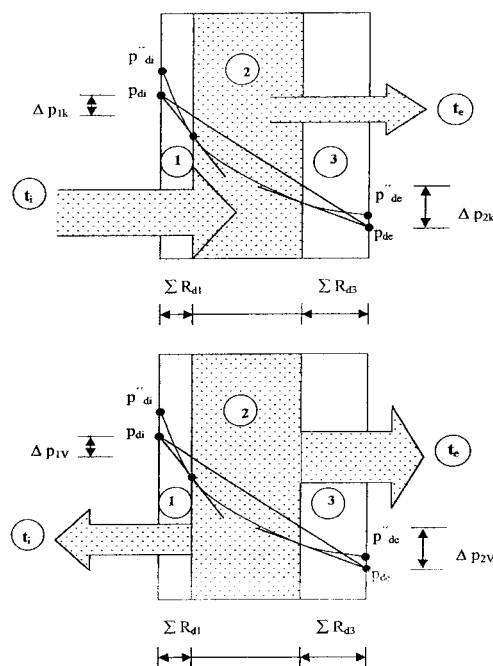

Fig. 1 Graphical illustration of the process of water vapour condensation and evaporation from the wall

References

- [1] POTOČEK, K., POTOČEK, T.: *Dodatočné zateplenie obvodových stien vykurovaných budov z pohľadu kondenzácie vodnej pary*, Tepelná ochrana budov, Praha 3/2002, ISSN 1213-0907.

EFFECT OF STIRRUPS SPACING CHANGE ON ACHIEVING LIMIT CRACK WIDTH

Cracks belong to deformation effects caused by action on reinforced concrete beams. They arise at the regions of maximum bending moments – vertical cracks, and at the shear regions – slant cracks.

A characteristic critical slant crack shows the maximum width from slant cracks. It was observed on reinforced concrete beams.

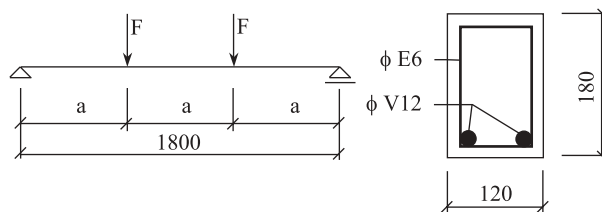

Fig. 1 Characteristics of tested beams

An original mathematical model was used to express a development of the slant crack width (for the chosen concerned parameters). The model is expressed by a general criterion equation:

$$\frac{w_{3q}}{a} = f \left(\frac{Q}{b \cdot h \cdot R_{b,exp}} \cdot \frac{A_{ss} \cdot R_{ss}}{A_{st} \cdot R_s} \cdot \frac{c}{s_s} \right). \quad (1)$$

The experimental data were processed to a mathematical relation by means of the criterion equation. By consecutive modelling, we obtained a relation which enabled to find out how the change of stirrups spacing would affect the development of crack width and at which value of shearing force $Q = Q_m$ the crack width would achieve the limit value $w_{q,lim} = 0.2$ mm.

Shearing forces Q_{lim} corresponding to the limit value of inclined crack width Table 1

Stirrups spacing s_s [mm]	0.05	0.06	0.07	0.08	0.09	0.10	0.11	0.12
Shearing force Q [kN]	37.56	31.29	26.82	23.47	20.86	18.77	17.07	15.64
$w_q = 0.2$ mm								

DIAGNOSTICS AND EVALUATION OF ROAD PAVEMENTS

The Department of Highway Engineering has paid much attention to questions of pavement serviceability and efficiency. Recent research activities of the department have related to diagnostics and evaluation of road pavements in term of skid resistance, evenness, surface state and bearing capacity.

The main problem solved in the area of skid resistance was a theoretical question of interaction pavement – tire. Results were used as a basis for the development of the technical regulation [1] for skid resistance measurements using SKIDDOMETER BV 11. The Slovak Road Administration (SRA) used this equipment for routine measurements. Skid resistance classification criteria for diagnostics by SKIDDOMETER BV 11 were carried out on the basis of comparison measurements with other evaluation methods.

New equipment for dynamic quantification of longitudinal unevenness was developed in the area of pavement evenness diagnostics. Profilograph GE simulates the model of a quarter car. The

parameter of dynamic transfer was calibrated through power spectral density and the model was verified by a comparison of measured and simulated values (Fig. 1). Next activities were realised in the area of road evenness diagnostic and evaluation:

Conversion among methods of skid resistance evaluation [2] Table. 1

Texture depth by sand patch test - h_p	Friction coefficient by portable skid resistance tester - f_k	Friction coefficient by Skiddometer - M_u
0.22	46	0.53
0.55	60	0.68
0.80	71	0.79

- analysis of longitudinal unevenness influence on dynamic response of the model of quarter car,

- simulations of dynamic response of real cars models,
- analysis of qualitative characteristics of IRI and marginal conditions of its measurement and evaluation.

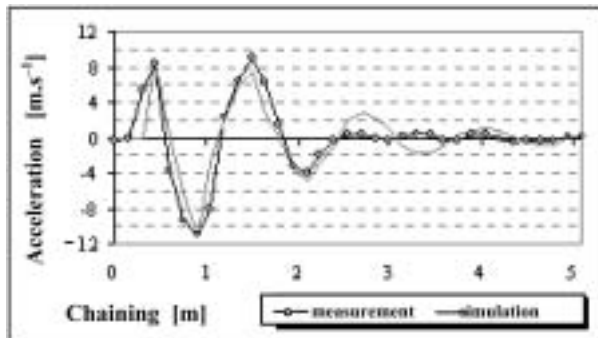

Fig. 1 Measured and simulated values [3]

All the results obtained in this field are in detail described in [3] and [4]. One of practical outputs is the technical regulation [5] for measurement and evaluation of asphalt pavement unevenness. Technical regulation is valid for PROFILOGRAPH GE, only.

Diagnostics and evaluation of asphalt pavements bearing capacity is an inseparable element of the Pavement Management System (PMS). Simulation of heavy vehicles impact to the pavement struc-

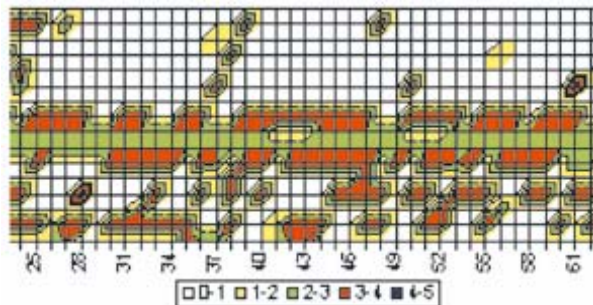

Fig. 2 Graphical interpretation of pavement evaluation

ture was carried out for the decision-making procedures intent on response to impulse load. Methods for determination of deformation characteristics of pavement layers from a deflection bowl, calculation of pavement residual life and necessary overlay were developed during research in this area. Practical output of these activities is the technical regulation of SRA for the measurement and evaluation of asphalt pavement bearing capacity using deflectometer FWD KUAB 2m - 150 [6].

Evaluation of road pavements according to their surface state is a diagnostic sphere where the department has been involved for the longest period of time. The products of research are methodologies for detailed visual surveys [7] and rapid visual surveys [8]. In addition the software for processing of collected data was developed at the department and the classification criteria related to pavements with asphalt concrete surface were defined.

References

- [1] Technical regulation *TP SSC 05/2000* - Measurement and evaluation of asphalt pavements skid resistance by SKID-DOMETER BV 11, SSC Bratislava, 2000 (In Slovak)
- [2] ČELKO, J. a kol.: *Surface characteristics of pavements*. Pavement serviceability. ŽU v Žiline, 2000 (In Slovak)
- [3] DECKÝ, M.: *Dynamic interaction vehicle - pavement from point of view of longitudinal evenness*, 2003 (In Slovak)
- [4] KOVÁČ, M.: *Longitudinal unevenness of pavements*, Thesis, 2003 (In Slovak)
- [5] Technical regulation *TP SSC 04/2000* - Measurement and evaluation of asphalt pavements unevenness by PROFILOGRAPH GE, SSC Bratislava, 2000 (In Slovak)
- [6] Technical regulation *TP SSC 03/2000* - Measurement and evaluation of asphalt pavements bearing capacity by FWD KUAB 2m - 150, SSC Bratislava, 2000 (In Slovak)
- [7] Technical regulation *TP SSC 02/2001* - Execution and evaluation of detailed visual surveys of asphalt pavements, SSC Bratislava, 2001 (In Slovak)
- [8] Technical regulation *TP SSC 07/2002* - Rapid visual surveys by VIDEOCAR. Execution and evaluation, SSC Bratislava, 2002 (In Slovak)

Jaroslav Šíma - Peter Polónyi - Peter Pisca

GEODETIC MEASUREMENT OF BRIDGE OBJECT DURING RECONSTRUCTION

The present condition of road infrastructure forces us to its repeated reconstructions. The bridge objects are first to repair from the safety aspect. One of them was bridge object No. 70-018 in Dolný Kubín. The bridge consists of two bridge fields. Emergency

condition of the bridge object forces the Slovak Road Administration towards its total reconstruction. For cross beam strengthening there was applied carbon fiber technology from SIKA Company. Because of the high traffic and no traffic diversions, the closing of

both traffic lanes was not possible; therefore the bridge reconstruction was carried out in several phases. The first phase consisted of the right traffic lane reconstruction and after finishing work the reconstruction was moved to the left traffic lane. Geodetic work follows the similar way.

The reference net consists of 9 points, which were arranged on the fixed objects outside the bridge and stabilized by marks. So they were not touched with the building activity. Observation points were stabilized by mortise marks in the basic construction of the armored concrete slab of the bridge according to designer's layout. 10 points were in every bridge span.

The method of geometric leveling from midpoint with technology of very precise leveling was used. For measurement the following digital instruments were used: NA 3003 and NA 2002 from LEICA Company, complemented with special code invar staffs GPCL3 and GPCL2.

The measurement was carried out in 6 phases according to

Table 1

Phase	Date	Activity
Basic	15. 7. 02	Original bridge
1.	18. 7. 02	Unload upper construction
2.	27. 7. 02	Activation of the laminations of the 2nd span
3.	6. 8. 02	Activation of the laminations of the 1st span
4.	6. 9. 02	Bridge with footpath
5.	12. 9. 02	Loading test



At the beginning of each phase of measuring the stability of the points of reference net was verified. After the calculation of the stability of the reference points we measured and interpreted the bridge object deformation as the cause of reconstruction influence. The deformations were measured on the remark points. The graphic representation of the deformation evolution on the left part of the bridge object is displayed in Figure 1.

Accuracy of determination of deformation is given by the analyses carried out after each phase of the measurement. It is characterized by posteriori mean error, m_0 [mm]. An analysis of the accuracy acknowledges that height changes higher than 0.4 mm were considered to be actual deformations.

The cooperation of the project engineer and geodesist is necessary during all reconstruction of the bridge object, where project engineer verifies theoretical values with the geodetic measurement. The whole reconstruction of the bridge took 2 month. At present, the reconstruction of the bridge is over and is open to traffic.

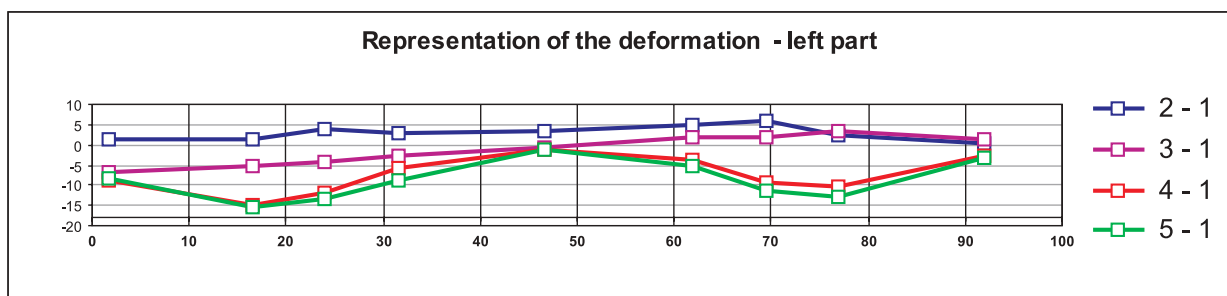

Ladislav Bitterer

MEASUREMENT OF LANDSLIDE DEVELOPMENT IN OKOLIČNÉ - HÁJ IN THE RAILWAY KOŠICE - ŽILINA IN 255,0-255,5KM

Since 1971, the department of geodesy of the University of Žilina has measured the flow landslide in Okoličné. Till now, 48 stages of measurements have been carried out.

All the surveying and calculations consists of: the reference points stability verification, the spatial position measurement of the observed points laying on landslide and interpretation of adjusted

spatial changes with the Test of null hypothesis. The observation of the shoot surface development and water regime condition is the important part of surveying work, too.

In the present time we use calibrated electronic theodolite TC 1700 Leica with unavoidable accessories. The least square method and other procedures of mathematical statistics are used to judge the reference point stability. In yearly stages of measurements the maximal points shifts produce the values under 10cm. The figure shows the approximation of positional changes development adjusted with polynomial 5°.

The measurement of landslide development in Okoličné is common project of University of Žilina and State geological institute of Dionysus Štúr, named: Particular monitoring system – geological factors, with subsystem: 01 – landslide and others slope deformation.

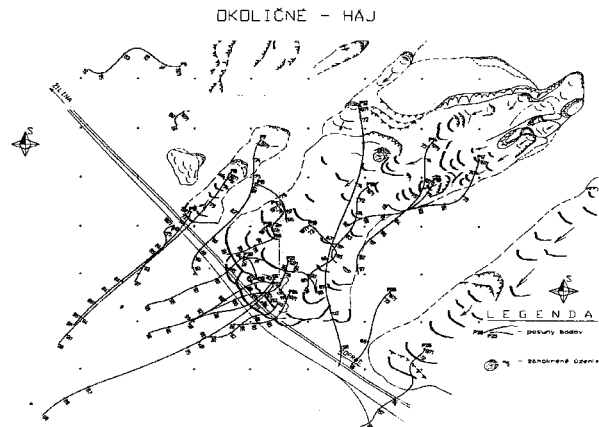

Ján Čelko – Eva Holeščáková

MODELLING OF TRAFFIC RELATIONS AT A REGION TERRITORY

When creating new area-administration units transport and traffic knowledge is a significant problem. First of all, it is because of flexible solution of traffic limitation allowing – in the case of traffic network sections diversion or enclosing and by different arrangements simulation with an optimal traffic repartitioning. The model allows choosing an optimal variant of solution and rounding to more economic useful solution of the regional traffic. In addition, the model can be used for traffic coordination and ordering, which could be very acceptable for the public transport regulation.

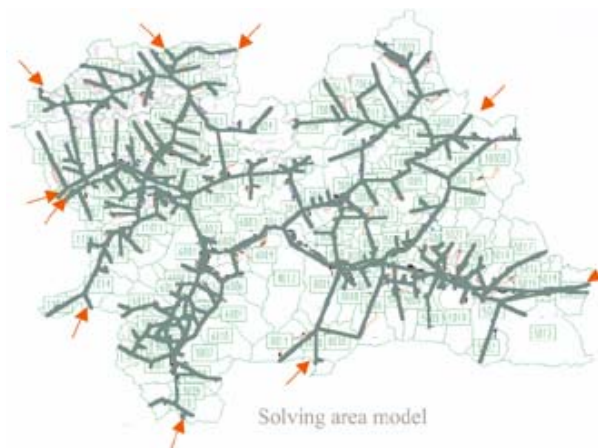

The VISUM software was used for solution. The software enables a modelling of the traffic systems, traffic load and the

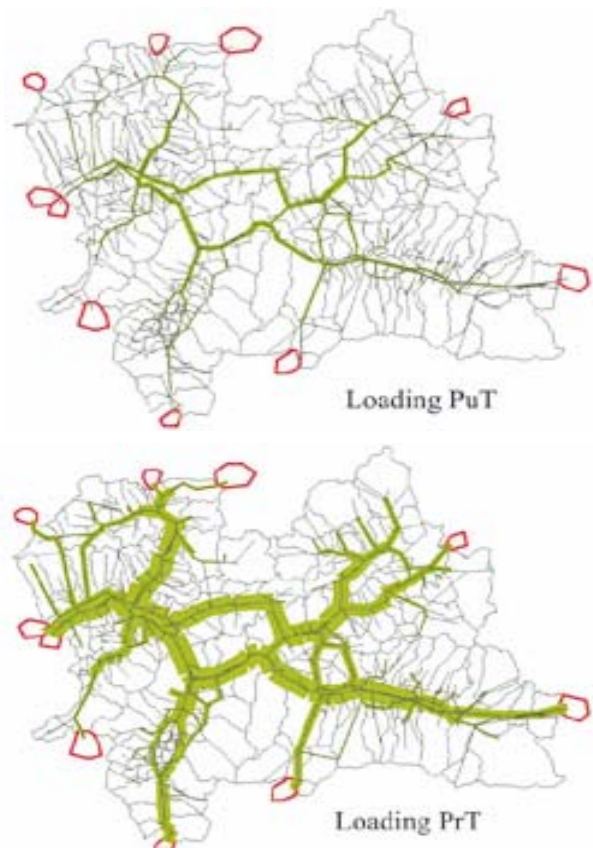

Jozef Štubňa

GEODETIC MEASUREMENT OF THE SHIFTS IN BARRAGES

Big and atypical constructions – barrages including – require supervision of their stability and functional reliability in time of the construction as well as in time of their working order. Geodetic methods of the shift measurement, because of giving quasi – absolute shifts in comparison with close and remote surroundings, give a reliable picture of the positional and level stability of the work. The staff of the Department of Geodesy, Faculty of Civil Engineering, University of Žilina have been measuring the positional shifts of the water construction Liptovská Mara from 1976 and the positional changes of the oldest gravitational dike the Orava barrage from 1997.

Methods of measurement. *The object of the barrage is characterised by the watched points, the position of which is appreciated in connection with relative points representing the close and remote surroundings. The shifts of the crown of the dike in horizontal direction are determined by the measurement from a deliberate line of sight for both barrages. The inspected points on the air front-side of the barrage are measured by trigonometric method. The inclination of the upper part of dam is determined by the pendulum and from the results of a very precise levelling. The shifts in vertical direction are measured by a very precise levelling.*

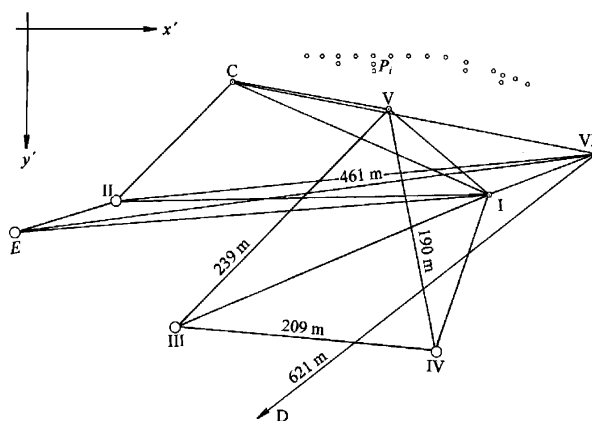

Trigonometric method. *The trigonometric method is applied to determine positional shifts of mentioned barrages that give objective results about inspected points but also the picture of close surroundings of an observed object. The supervised points are situated on the air side of barrage. Their horizontal shifts are judged with respect to relative /fixed/ points. The photo shows the view on Orava barrage – the net of relative and inspected points.*

The basis for determination of horizontal shifts is represented by a very precise measurement of angles on relative points on trigonometric net. The principle of trigonometric method is well known among the surveyors. The most important task in analysing the shift of inspected points is to determine the positional stability of relative points and to determine the shift of inspected points. The concrete information about the above mentioned barrages is published by the author in scientific geodetic journals. Geodetic measurement of shifts, sittings and inclinations together with other measurements belong to the most important methods in determination of stability of dams and other big constructions.

EFFECT OF DEGRADATION PROCESSES OF CONCRETE AND REINFORCEMENT ON THE REMAINING LIFETIME OF STRUCTURES

Durability and reliability of reinforced concrete bridge structures depends mostly on the environmental condition to which they are exposed. The most significant effect has acting air CO_2 and Cl^- . These factors cause corrosion of concrete and reinforcement decreasing lifetime of reinforced concrete structures. Corrosion of the reinforcement is the most frequent cause of reinforced concrete structures failures. The causes of reinforcement corrosion can be subdivided into chemical and electrochemical effects.

Corrosion is evoked by many factors. Chloride ions Cl^- from salts applied by winter maintenance of the roads and carbon dioxide CO_2 from environmental atmosphere are the most important from the viewpoint of reinforcement corrosion. Two basic types of reinforcement corrosion should be distinguished in concrete structures. General corrosion performs continuously over a substantial area of reinforcement. This is a relatively slow process, producing only a small reduction in the bar cross-section, but it causes substantial disruptions of the concrete cover. Localized corrosion is much more rapid than general corrosion. It leads to substantial local reductions in the bar cross-section. In the case of chloride ions diffusion into concrete, it shall be remembered, that con-

crete is neither an isotropic medium nor a homogeneous material. However, for many problems encountered in practice it is sufficient to consider concrete as a quasi-homogeneous material, where the diffusion of chloride ions of which can be considered using Fick's laws of diffusion.

The result of many studies of the relationship between various properties of hardened concrete and the long-term performance of concrete bridges showed a number of connections between concrete properties and performance under different environmental and traffic conditions. On the basis of these studies 5 bridges were randomly chosen. They were located in various places in the country on highway sections with various traffic and chloride loads and with an age composition. The results of calculation of the time t_0 , when chloride ions penetrate through the concrete cover achieving reinforcement and the corrosion starts are show in table 1.

Fick's diffusion laws are suitable methods for the forecast of future chloride penetration and for evaluation of the remaining lifetime of concrete bridges.

Table 1

Bridge No.	Chloride content [$\text{kg}\cdot\text{m}^{-3}$]		$C_s^{1)}$ [% by cont.wt.]	$D_c^{2)}$ [mm^2/year]	Concrete cover remaining ³⁾ lifetime t_0 [year]
	In 13 mm depth	in 45 mm depth			
1	17.01	12.51	0.190	669	1
2	20.63	7.06	0.281	71	12
3	17.80	14.23	0.193	919	1
4	24.39	10.80	0.314	106	10
5	19.28	10.92	0.233	182	5
average:			0.242	390	

¹⁾ C_s is maximum chloride content in the concrete surface (% of dry concrete weight)

²⁾ D_c is diffusion coefficient in mm^2/year

³⁾ Calculation are made with $C_{cr} = 0.0571$ % of dry concrete weight

EFFECT OF DEGRADATION FACTORS ON EXISTING BRIDGE RELIABILITY

The reliability of existing bridge structures is significantly affected due to many factors from which the reinforcement and structural steel corrosion together with effect of traffic action are the most important. In the case of concrete structure, the reinforcement corrosion is caused by concrete carbonisation, that is CO₂ diffusion to the concrete member. The reinforcement corrosion will begin after CO₂ penetration through the concrete cover and achieving reinforcement bars in time to (so called passive stage). Then the active stage of reinforcement corrosion begins affecting the reinforcement resistance significantly. The effect of reinforcement corrosion on the reliability of reinforced member was observed by means of parametric study using two models of passive stage length to calculation according to Schiessl [1] and Frey [2]. Loss of rein-

forcement diameter d_s [t] due to uniform corrosion was taken into account in accordance with Andrade model [3] and Thoft-Christensen model [4]. Results of the parametric study of time-variant reliability courses of reinforced member subjected to bending presented in [5] are partially shown in Fig. 1.

Effects of the traffic actions on bridges were observed on the real railway bridge structure by means of in-situ measurements supplemented by a computer simulation of train models passages over the computational model of bridge structure. The results of the stress response of the upper and bottom chord of the observed truss main girder were statistically processed and are shown in Table 1.

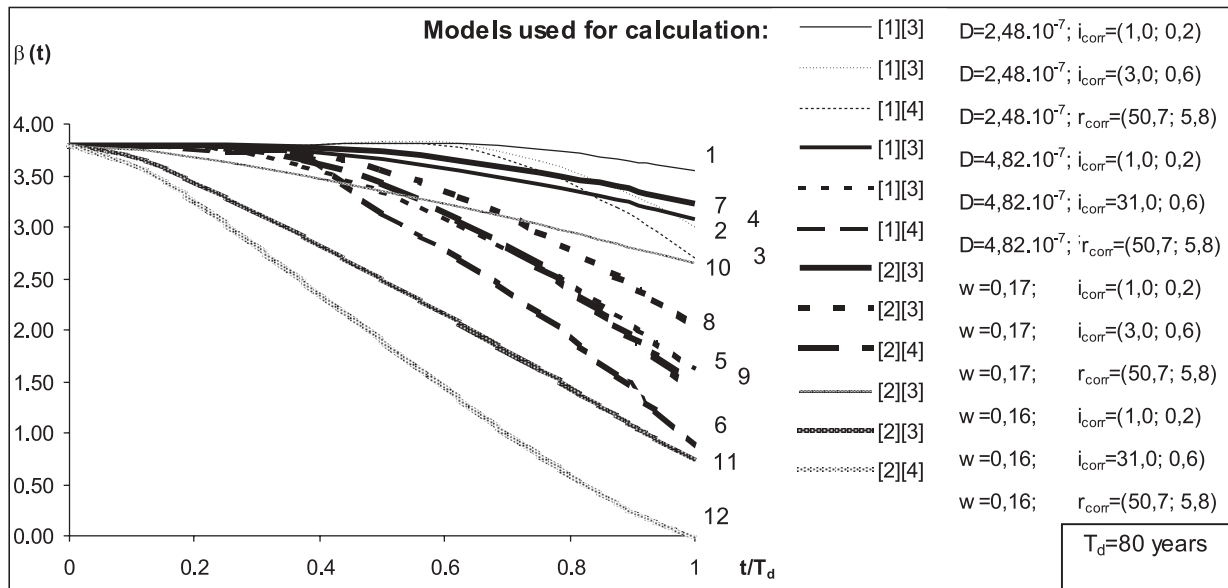

Fig. 1 Time-variant reliability index β [t] of the member subjected to bending under corrosion attack.

Statistical evaluation of traffic load effects

Table 1

Mean value		Standard deviation		Coefficient of variation		I - bias factor	
Bottom chord m_{sS4} [Mpa]	Upper chord m_{sH4} [Mpa]	Bottom chord s_{sS4}	Upper chord s_{sH4}	Bottom chord v_{sS4} [Mpa]	Upper chord v_{sH4} [Mpa]	Bottom chord I_{s4}	Upper chord I_{H4}
23.87	-32.84	4.58	6.66	0.19	-0.20	0.47	0.47

Using Rackwitz - Fiessler method of design point, the results of computer simulation were applied to determine values of partial safety factors for dead $\{\gamma_{FG} = 1,10\}$, long-term affecting $\{\gamma_{FQ} =$

1,20\} and traffic load $\{\gamma_{FT} = 1,20\}$ corresponding to the reliability level $\beta_t = 3,50$ [6].

References:

- [1] SCHIESSL, P.: *Einfluss von Rissen auf die Dauerhaftigkeit von Stahlbeton und Spannbetonbauteilen*. Deutscher Ausschuss für Stahlbeton, Heft 370, Berlin 1986
- [2] FREY, R.: *Untersuchungen der zwanzigjährige Carbonatisierung von Betonen*. Beton 43, 1993, Heft 3. p. 116-120.
- [3] ANDRADE, C., SARRIA, J., ALONSO, C.: *Corrosion Rate Field Monitoring of Post-tensioned Tendons in Contact with Chlorides*. International Conference "Durability of Building Materials and Components", Stockholm, 1996, p. 959-967
- [4] THOFT - CHRISTENSEN, P.: *Reliability Based Expert System for Bridge Maintenance*. Tekno Vision Conference, Denmark, 1992
- [5] KOTEŠ, P., VIČAN, J., SLAVÍK, J.: *Influence of Reinforcement Corrosion on Reliability of Existing Concrete Structures*. Communications 4/201, p. 41 - 49
- [6] VIČAN, J., LUČIVJANSKÝ, J.: *Traffic Actions and Traffic Loading Capacity of Railway Bridges*. International Conference "TESE '02", Ražské Teplice 2002, p. 151-156 (in Slovak)

Jaroslav Šima – Anna Seidlová

GEODETIC WORK IN CONSTRUCTION OF THE SKI JUMP K-90 IN THE HIGH TATRAS

Ski jumping or ski flying are attractive sports disciplines. Needless to say, both ski jumping and ski flying are dangerous. Therefore, ski jump profiles must meet universal parameters prescribed by the FIS. The working-out and application parameters have to be performed in compliance with the designs prepared by experts



of the FIS technical commission in collaboration with the TU in Munich. The basis is formed by the mathematical processing of soldering graphics vintage of competitions in the season 1996-97. Application parameters are preceded by precise measurements of the longitudinal profile in intervals of 1-2 m using a total station Leica 1700. The projected and adjusted profile of the ski jump reconstruction was traced in November 1998, making some arrangements during the world Universidad. In the years 2000 - 2001 the ski jump profile was repaired and its surface was covered with artificial material. The basic foundations are longitudinal and transversal wooden reinforcements. In the point of intersection it was needed to direct positional and level detailed items, and calculate their 3D position data. Comparing these coordinates with the project we determined the height differences that served for the setting of the whole gridiron.

The final deformations were adjusted in a numeric and graphic form following the worked-out digital model. After the rectifications (stabilization in a V- shape) the timbering was put. On the timbering artificial material was set, which enables the all-year-round operation of the ski jump profile K-90. It included 1760 points determined by means of a trigonometric method. The terrain work

was carried out within one day and the results were processed in two days' time.

The measurement accuracy is characterized by the standard deviation $m_{\Delta hp}$ that is calculated by means of the equation:

$$m_{\Delta hp} = \sqrt{m_{\Delta H}^2 + \left[(1 + \operatorname{tg}^2 \beta) \frac{d}{\rho^{cc}} \right]^2 m_{\Delta \beta}^2 + (m_{\Delta d} \operatorname{tg} \beta)^2}, \quad (1)$$

In the equation $m_{\Delta H}$ is mean error of height, β is vertical angle, $m_{\Delta \beta}$ is mean error of the measured vertical angles and $m_{\Delta d}$ is mean error of lengths. After substituting the least favourable values into the equation (1) $m_{\Delta hp}$ equals 4 mm for run-on tower and 3 mm for ski jump terrain. The total error is equal to duplex mean error and consequently we can say that both the above described surveying method and the total station (LEICA1700) are suitable for distinguishing the height changes in the ski jump profile which are higher than 8 mm. This accuracy corresponds to the demands concerning the accuracy for profile of the whole ski jump profile and confirms the right choice of the used technology as well as instrument.

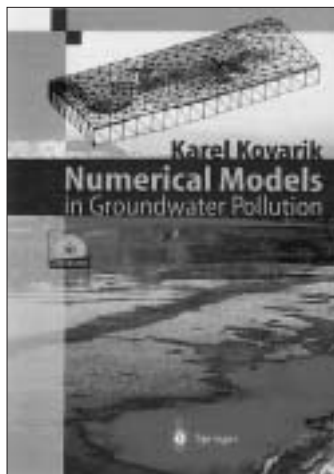

Numerical models in groundwater pollution

Karel Kovářik

- * Hardcover: 218 pages ; Dimensions (in inches): 0.56 x 9.50 x 6.37
- * Publisher: Springer Verlag; Book and CD-ROM edition (May 2000)
- * ISBN: 354066792X

Book Description

Mathematical models are effective tools to solve different tasks predicting pollutant movement. The finite difference method is the oldest, but still remains widely used in hydrogeological practice. However, this method is not very useful to construct new transport models because it cannot approximate the shape of remediation elements exactly. Therefore the book is concerned with the FEM (Finite Element Method) and BEM (Boundary Element Method), and also with the comparison of advantages of these methods in groundwater hydrology. The combination of the BEM and the random-walk particle tracking method, which seems to be a very useful tool to model the spread of pollution in groundwater, are also presented. The computer programmes were developed on the basis of theoretical backgrounds of these methods. They use the Visual C++ programming language for Windows 95/NT platform and will be included in the book.

Book Info

Discusses the basic equations of a groundwater flow and of the transport of pollutants in a porous medium. Concentrates on the fundamentals of numerical mathematics. Studies each method of numerical modelling separately, and more.

Keywords

Groundwater-Pollution-Mathematical models.

Pavement surface characteristics

Pavement operation ability

Authors: Ján Čelko, Martin Decký, Daniela Ďurčanská, Andrea Gavulová,
Milan Valuch, Peter Múčka

Publisher: University of Žilina, 2000
ISBN 80-7100-774-9

The authors present basic theoretical knowledge in the area of roughness, unevenness and surface state and their application at evaluation of operation ability of bitumen pavements. The book is designed for experts of highway engineering, students of technical universities, research workers, project engineers, investors and building contractors.

The publication contains basic knowledge gathered from scientific and research activities for many years and also practical experiences from the projects solving – project of Pavement diagnostic, project of creation and introduction System of pavement management.

The individual chapters deal with equipment for measurement of surface properties of pavements. In the final chapter there are monitoring parameters evaluated in mutual connection and also in connection users costs and also surface properties in relation to transport safety.



Pavements mechanics

Pavement and stabilization areas design

Authors: Ján Čorej, Martin Decký, Jozef Komačka, František Schlosser, Eva Remišová,
Milan Valuch, Andrea Gavulová, Peter Múčka

Publisher: University of Žilina, 2001
ISBN 80-7100-862-1

The publication is based on knowledge obtained from research projects solved by the staff of the Department of Highway Engineering. It synthesizes results from diploma and dissertation theses and various professional sources from the area of pavement constructions.

The book covers four characteristic areas and is divided into twelve chapters. The first part contains input data concerning pavement construction design, tensions and deformation calculation. The second part is devoted to pavement design. The third part contains pavement diagnostic and overlay. The final part pays attention to economic aspects of pavement design.

The publication was published with support of the grant agency VEGA: 1/3127/97 Theoretical questions of improvement of pavement operation ability and 1/41456/97 Analysis of pavement mechanics influence on their surface state.





Regional communication service

Analyses, sketches, studies

Authors: Tomáš Hollarek, Ján Čorej and col.

Publisher: University of Žilina, 2002

ISBN 80-7100-957-1

The monograph offers a theoretical basis and practical guide for analysis of the present regional communication service and method of its optimal solving. It explains visions of particular subsystems of the communication system and their assumptions, integrates terminology and on practical examples from the region of Žilina presents the most important approaches toward the design of the communication service in the observed region.

The book is written for traffic engineers, civil engineers, and engineers in areas of postal services and telecommunications, and information technology. It includes the design methods of the regional communication system, methods of assessment level of system quality, methods of finding the optimal service in the region.

The monograph is the result of activities within the framework of the project: C 519/2 "Model of regional communication service" solved at the University of Žilina in co-operation with the Research Institute of Transport in Žilina during the years 1998 - 2000.



Assessment of roads and highways impacts to environment

Noise and air pollution from road traffic

Authors: Daniela Ďurčanská, Ján Čelko, Martin Decký, Ferdinand Heseck, Ján Šimo, Milan Valuch, Anna Čajková

Publisher: University of Žilina, 2002

ISBN 80-8070-029-X

The publication presents designers various questions related with environment and traffic. The authors present basic theoretical knowledge in area of noise and air pollution impacts from traffic and their application in assessment and evaluation of the designed road lines.

The book was written on the base of knowledge gathered from scientific and research activities during many years and also on the base of practical experiences during solution of project documentations EIA. The attached CD contains examples, form and mode of EIA documentation processing. Also it includes photo-documentation of finished measures to reduce traffic impact on the environment.



FACULTY OF MANAGEMENT SCIENCE AND INFORMATICS

FACULTY OF MANAGEMENT SCIENCE AND INFORMATICS

Dean: Assoc. Prof. Karol Matiaško, PhD.
Phone: +421-41-5651014
Fax: +421-41-5652044
E-mail: dekan@fria.fri.utc.sk

Vice-deans:

Assoc. Prof. Vladimír Jamrich, PhD.

Phone: +421-41-5134107

E-mail: jamrich@fria.fri.utc.sk

Assoc. Prof. Matilda Drozdová, PhD.

Phone: +421-41-5134117

E-mail: hittmar@fria.fri.utc.sk

Prof. Jaroslav Janáček, PhD.

Phone: +421-41-5134106

E-mail: slovak@fria.fri.utc.sk

*The Faculty of Management at the University of Žilina was established in July 1990 as a result of a decision by the Academic Senate. In 1993 a new branch **Management and Information Systems** was created and in 1996 the name of the Faculty changed to the **Faculty of Management Science and Informatics (FMSI)**. This name more precisely reflects the importance of information technology in the profile and orientation of the Faculty.*

The Faculty primarily specializes in managing activities in extensive systems. These include problems of managing and optimizing the transfer of products, passengers and information, as well as the designing of integrated interactive information systems for decision making support including economic connections and technical background.

The Faculty is interested in control and information systems with application for management, and transport systems from small-sized networks, such as a firm or company, through medium-sized, such as a region, to large-sized networks.

Mathematical knowledge is an unavoidable condition in accomplishing the Faculty's goals. That is why the Faculty pays attention to applied mathematics and to designing mathematical models as a basis for algorithmic information, decision-making processes and their optimization.



Departments of the Faculty

The FMSI has eight departments and two facilities located outside Žilina, which create its professional structure. They are:

- Department of Mathematical Methods
- Department of Informatics
- Department of Macro and Microeconomics
- Department of Technical Cybernetics
- Department of Information Networks
- Department of Transportation Networks
- Department of Management Theories
- Department of Software Technologies
- Sub-Campus in Prievidza
- Sub-Campus in Ružomberok

Educational program of the Faculty

The educational program of the Faculty is divided into the following parts:

- **Bachelor's Degree** - this is a three-year study for high school graduates. Curricula in the first year of study are common with the study in Master's Degree. The students can choose this form of study either at the beginning or during the first year of study. The graduate obtains the degree of "**Bachelor (Bc.)**". After the completion of study, s/he can continue in the Engineer Programme if s/he meets the requirements for this form of study.
- **Master's Degree** - this is a five-year study for high school graduates. The study ends with a state exam and a defense of diploma thesis. Graduates obtain the academic degree of "**Engineer (Ing.)**".
- **Postgraduate Degree** - this doctoral study is for graduates awarded the degree of Ing. who decided to achieve qualification for their scientific work. The study lasts three years. The doctoral degree requires 3 semesters of advanced study, satisfactory completion of a comprehensive examination, then after 3 semesters, submission of a written dissertation work based on independent original research that must be a significant contribution to the field of study and an oral examination that is a defense of the dissertation research. The graduate obtains the scientific academic degree of "**Doctor of Philosophy (PhD.)**".

The doctoral study at the Faculty is provided in the following scientific branches:

- **Automation and Control, Specialization Technical Cybernetics**
- **Applied Mathematics**
- **Transport and Communication Technology**
- **Applied Informatics**

Continuing Education – this study is intended to increase knowledge in one of the branches related to the Faculty's orientation. The Faculty provides education with the following opportunities for citizens of various age:

- accredited qualification and requalification courses
- regular study (evening courses, weekend courses, modular courses)
- special short-time courses
- vacation and summer courses
- special training

In the educational activities for which the Faculty has been accredited (Information and Control Systems, Applied Mathematics and Informatics), the graduates obtain a corresponding certificate.

The Branches of Study at the Faculty

The Faculty provides study for Bachelor's and Master's Degrees in these branches of study:

- **Information and Control Systems**

This form enables its students to receive university education in scientific and specialized branches related to the management of large systems. The processes in extensive systems are under the control of various physical and economic rules and technical means for managing those processes which are mostly represented by computers. Graduates can be of use in the sphere of transport and communication, also in designing, managing and securing information and management systems in banks, government, tourism and in the building of information systems of cities and regions, modeling and designing their infrastructures, prognosticating their evolution, etc. During the first two years students are without specialization and study all together. After the first two years of study they can choose their branch of specialization from the following possibilities:

- **Applied Informatics**
- **Management**
- **Information and Control Technique**

for the Master's Degree,

or after the first academic year

- **Information Technology**

for the Bachelor's Degree

In 2001 Faculty obtained the accreditation for a new branch of study **Informatics** in Bachelor's Degree, which started in the academic year 2002 –2003.

- **Applied Mathematics**

The graduates can work at economic or technical universities or scientific and research institutions, as well as in development centers of large companies and consulting services. They can also continue in economic, technical and theoretical mathematical postgraduate studies. After two years of study the students can choose from one of following specializations:

- **Economic specialization**
- **Physical-Technical specialization**

Applicants for the Bachelor's and Master's Degrees are expected to have completed secondary general education with a school-leaving certificate. They are admitted to study at the Faculty in accordance with the results of their entry examinations in mathematics and physics or informatics.

Scientific and professional orientation of the Faculty

The Faculty is oriented to the following scientific fields:

- Analysis, synthesis and design of integrated information and control systems
- Creation of integrated systems for the support of decision-making, including its economic correlations and technical equipment requirements
- Management, marketing, logistics and enterprising in the general field of transport and communication systems
- Problem solving design in transport and communication systems and relative tasks of control
- Control and optimization of transportation of products and persons
- Control and optimization of database creation, transmission and data processing
- Analysis, synthesis and design of multimedia information systems
- Analysis, synthesis and design of geographical information systems
- Design and realization of simulation components for communication networks and systems
- Design and realization of technical means for information and control systems

List of Universities and Institutions cooperating with the Faculty of Management Science and Informatics

Universities:

- Technical University Dresden, (Germany)
- Technical University Braunschweig (Germany)
- Brandenburg Technical University Cottbus (Germany)
- University of Applied Sciences and Technology, Dresden (Germany)
- University of Applied Sciences Darmstadt, (Germany)
- University of Applied Sciences Leipzig, (Germany)
- Technical University of Vienna (Austria)
- National Institute of Telecommunication, Evry, (France)
- University of Poitiers (France)
- Linköping University (Sweden)
- University of Vaasa (Finland)
- Polytechnic Jyväskylä (Finland)
- Helsinki University of Technology (Finland)
- Molde University College (Norway)

- University of Essex (UK)
- University of Leeds (UK)
- University of Valencia (Spain)
- University of Gent (Netherlands)
- University of Ostrava (Czech Republic)
- University of Pardubice (Czech Republic)
- West Czech University (Czech Republic)

Institutions:

- Siemens Österreich (Austria)
- Alcatel (Austria)
- Österreichische Bundesbahn (Austria)
- Deutsche Telecom (Germany)
- Deutsche Bundesbahn (Germany)

- Scheidt & Bachmann (Germany)
- Siemens, A.G. (Germany)
- Siemens Business Services (Germany)
- Volkswagen, A.G. (Germany)
- SOFTGATE, GmbH, Erlangen (Germany)
- Schweizerische Bundesbahn (Switzerland)
- International Telecommunication Union (Switzerland)
- France Telecom (France)
- TDJ Harbin (China)
- CNET France (France)
- ESC Bordeaux (France)
- ETSI Nice, Sophia Antipolis (France)
- Object Consulting (Czech Republic)
- Czech Railways (Czech Republic)

Jaroslav Janáček – Petr Cenek – Ludmila Jánošíková – Luboš Buzna – Peter Bednár

THE DESIGN OF OPTIMAL TRANSPORTATION SYSTEM STRUCTURE

Department of Transportation Networks, Faculty of Management Science and Informatics

This topic of research concerns strategic decisions made by top management on the structure of a large sized system. Such a decision has great long-term impact on effectiveness of the system. The concerned systems do not include only the transportation system themselves but also many applications to one-to-many distribution system designs or many-to-many distribution systems. The set of the concerned systems may be also extended by various public administration systems, which spread over a large area. The structure of the systems is mostly determined by locations of important facilities, which is a common denotation of terminals, marshalling yards, airports or hubs, when transportation system is designed. When a distribution system is built up, then facility denotes warehouse or place where distributed goods are transhipped. Relating to a public administration system design, the facility means some office or administration center.

Strategic decisions are made under uncertainty concerning future costs, flows, demands and other parameters, which change in time and which can be only roughly estimated at the time when decisions have to be made. Furthermore, decision makers have to take into consideration conditions and impacts, which can be hardly quantified.

Our research was focused on *decision support tool development*, which should be able to find optimal decision for the system structure in the case when an objective function and associated constraints are given. The support tool should offer the solution to a decision maker and enable him to revise the constraints and

objective function. The tool has to enable a dialogue with the decision maker and perform it until a satisfactory solution is met.

A substantial part of our research consists of the implementation of a branch-and-bound method for a large-sized uncapacitated location problem and of investigation of the algorithm behavior when the algorithm is used for real-size network problem solving [9]. We compared the algorithm properties with Daganzo's continuous approximation approach and proved advantage of the branch-and-bound algorithm for one-to-many distribution system design. We extended the abilities of the algorithm by possibility to process uncertain input data, which are described using triangular fuzzy numbers [5]. The next issue was another extension of the algorithm for the p-median problem solution [3]. To be able to work out many-to-many distribution system design, we suggested an approximation of the associated quadratic objective function [7], which enabled to reformulate the quadratic problem to the uncapacitated location problem.

The above-mentioned results of the research, which was supported by the VEGA 1/4328/97 and 1/7211/20 research grants, were used for the following applications:

1. Analysis of the transport optimal forming of a region

This study was carried out when the public administration system of Slovakia was changed, to demonstrate the impact of



Fig. 1. Transport-optimal administration partition

various planned political decisions on the administration center accessibility [2], [8].

The same tool was used in another study to reduce the transportation network to a sensible size with the purpose to enable OD matrix determination [1].

2. Decision support tool for marshalling yard allocation

A transportation system, which has approximately the same number of primary sources as a number of customers, seems to be a marginal case of a distribution system. This case includes such instances as cargo railway system, which provides transport of carriages between railway stations. In these cases demands of customers form a matrix of yearly flows from sources to places of destination. The fact that the unit cost of transportation is smaller when bigger bulks of items are transported approves concentration of flows between different pairs of sources and customers to stronger flows at least on a part of their way. This flow concentration needs terminals in which transshipment of transported items is carried out and bigger bulks are formed or, on the other hand, where bulks are split into smaller groups designated to different customers.

In contradiction to classical distribution systems in which big bulks leave the primary source, another situation emerges in the many-to-many distribution systems. Primary sources send relative small bulks of items and it is useful to concentrate them to bigger bulks in the terminals located near the sources and then to send these bigger bulks to remote terminals and to split them there.

We restrict ourselves to the distribution system in which a customer-source is assigned to only one terminal and an exchange of consignments between the customer-source and other primary sources or customers is done via this assigned terminal.

We have designed a way of linearization using the proportional coefficient α . This problem was solvable in the time of several tens of seconds thanks to the specific structure of the system of constraints. This property enables repetition of the computational process for different values of α and obtaining a more precise result used in the decision support system completion [7].

3. Natural distribution centers identification

Frequency of the location

Tab. 1

q	2	3	4	5	6	total
Šaľa	6	0	0	0	0	6
Bratislava	10	9	10	10	10	49
Detva	1	2	4	4	5	16
Hlohovec	1	3	2	2	2	10
Humenné	4	4	0	0	0	8
Košice	0	1	3	3	3	10
Levice	1	3	2	2	0	8
Martin	0	0	1	1	1	3
Michalovce	0	0	4	4	4	12
Nitra	0	3	5	5	5	18
Nové Zámky	0	0	0	0	2	2
Poprad	3	4	6	6	6	25
Považská Bystrica	6	6	6	6	6	30
Prešov	8	6	5	5	5	29
Prievidza	5	2	2	2	2	13
Rimavská Sobota	5	4	2	2	1	14
Ružomberok	5	4	3	3	3	18

This application deals with the structure design of a general distribution system, which is considered to supply the area of the

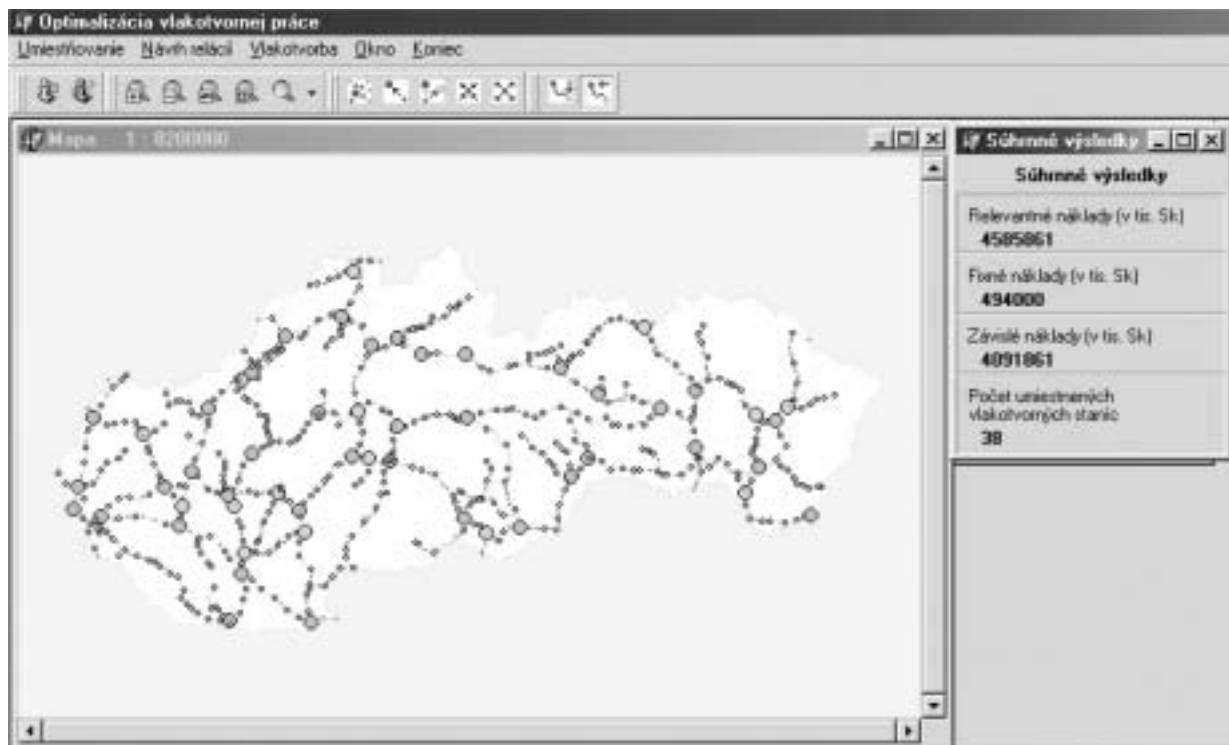

Fig. 2. A software tool for optimization of cargo services

Slovak Republic with a given sort of goods. The real density of population in the area is considered and it is assumed that the demand of goods is proportional to the number of inhabitants at the individual dwelling places. The goal of this contribution is to reveal a dependence of the distribution system structure on relative input unit costs under demographic and geographic characteristics of the Slovak Republic [3], [4].

The preliminary numerical experiments were carried out for the whole area of the Slovak Republic with 2906 dwelling places and with 70 possible sites of terminal location.

The ratio of unit cost of transport between a terminal and a customer and unit cost between a primary source and a terminal ranked from 2 to 6. The resulting natural distribution centers are plotted in the Table 1.

References

- [1] CENEK, P., JANÁČEK, J., JÁNOŠÍKOVÁ, E.: *Location of Transportation Districts at Modelling of Transportation processes in a region*. In: Communications - Scientific Letters of the University of Žilina, Vol. 3, No. 1-2, 2002, pp. 5-9
- [2] JANÁČEK, J.: *Transport-optimal Partitioning of a Region*. In: Communications - Scientific Letters of the University of Žilina, Vol. 2, No. 4, 2000, pp. 35-42
- [3] JANÁČEK, J.: *The Optimal Location Problem with the Conditional Flow Size*. In Proceedings of the 17th International Conference "Mathematical Methods in Economics", 14.-16.sept. 1999, Jindřichův Hradec, pp. 139-142
- [4] JANÁČEK, J.: *Analysis and Structure Design of Distribution Systems*. In Proceedings of the International Conference "Strategic Management and its Support by Information Systems", 8.-10. Sept. 1999, Horní Bečva, pp. 120-124
- [5] JANÁČEK, J.: *Location Problem under Uncertain Costs and Charges*. In: Proceedings of the 18th International Conference on Mathematical Methods in Economics. Prague, 13-15 Sept. 2000. ed.: Czech Society for Operations Research, Prague, 2000, pp. 85-90
- [6] JANÁČEK, J.: *Forming of Transport-optimal Region with Uncertain Weights of Regional Centres*. In: Proceedings of the conference „Quantitative Methods in Economics (Multiple Criteria Decision Making X), EU-Bratislava, The High Tatras, 30 Nov-2 Dec, 2000, pp. 77-82
- [7] JANÁČEK, J.: *Design and Analysis of Many-to-Many Distribution System*. In: Proceedings of the international scientific conference „Quantitative Methods in Economics, Dec. 5.-7. 2002, Nitra, pp. 119-123
- [8] JANÁČEK, J., JÁNOŠÍKOVÁ, E.: *Higher Territorial Units and Transportation Accessibility of their Centres*. In: Communications - Scientific Letters of the University of Žilina, Vol. 3, No. 1-2, 2002, pp. 66-72
- [9] JANÁČEK, J., KOVAČIKOVÁ, J.: *Comparing Dual Access Approaches for Exact solution of Location Problems*. Communications, Scientific Letters of the University of Žilina, 1999, No. 2, pp. 4-8

Valent Klíma¹ – Antonín Kavická¹ – Petr Cenek¹ – Lubos Sadlon² – Norbert Adamko¹ – Milos Zatko²

SIMULATION TOOL FOR TRANSPORT NODES DESIGN AND ECONOMISATION

Department of Transportation Networks¹, Department of Software Technologies²
Faculty of Management Science and Informatics

The tendency of creating and simulating 'digital worlds' can be observed and yields large-scale simulation models. The following features can be demanded from a large-scale simulation model: (1) the capability to reflect the behaviour of a real-world system in the required level of details, (2) the flexibility with respect to future modifications and extensions of the model, (3) an easy-to-comprehend way of presenting the results, (4) the user interaction with the simulation model, (5) the reusability of the simulation model and his components. The challenge is how to create such a simulation model in a limited amount of time and budget, especially when most of the demands are in conflict with each other.

An extended Agent Based Architecture (ABAsim) was developed as a method to achieve it. By means of this architecture, a simulation model that satisfies all above requirements can be created. Moreover, a library of models can be built, and by combining them, new models can be created.

Theoretical background

In the development of architecture of a simulation model, our methodology suggests first the creation of specialized agents responsible for solving defined problems. Further, it is necessary to define the structure of the simulation model itself. One of possible ways is to group individual components of proposed agents into layers according to their function. It seems to be convenient to separate components responsible for control and managerial tasks (managers) from components responsible for performing actions (effectors). Separation of control and processing parts of a simulation model makes the architecture more transparent and enables to exchange, if need arises, individual components with the high degree of flexibility. Thus, a simulation model consists of two layers: *management layer* with control and decision making properties and *processing layer*, consisting of effectors, which can be activated only by manager.

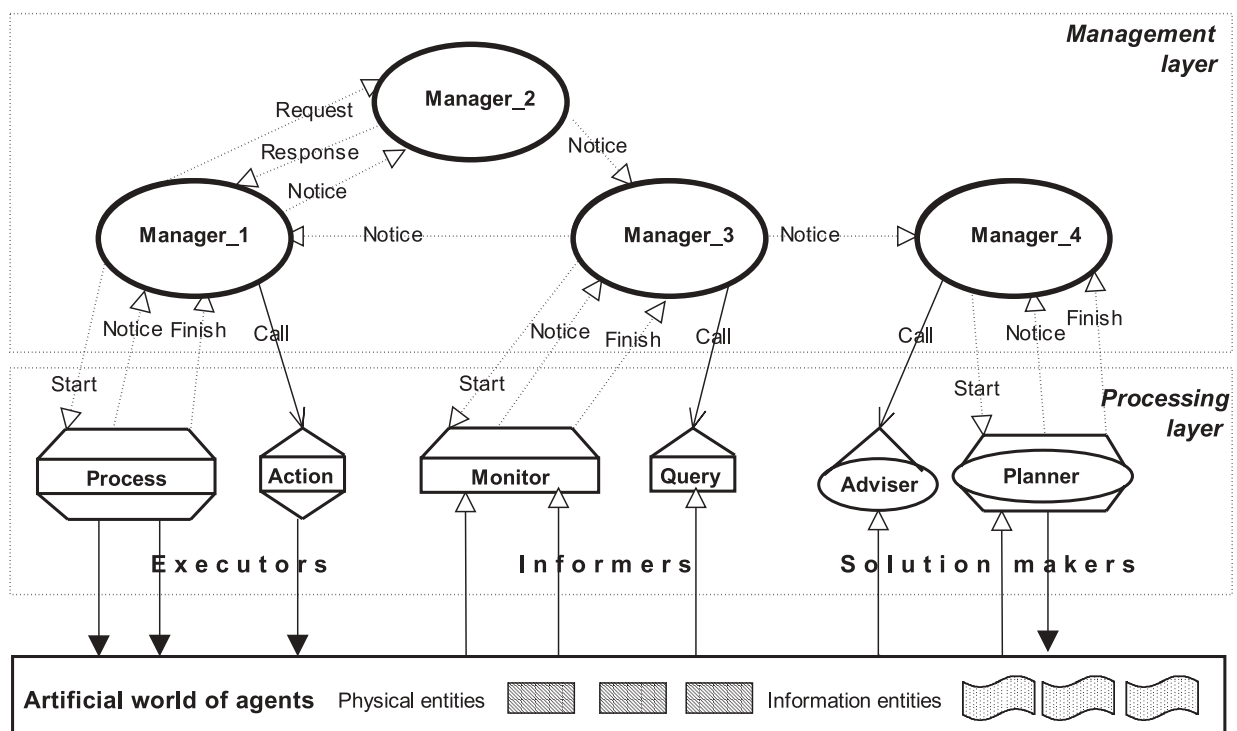

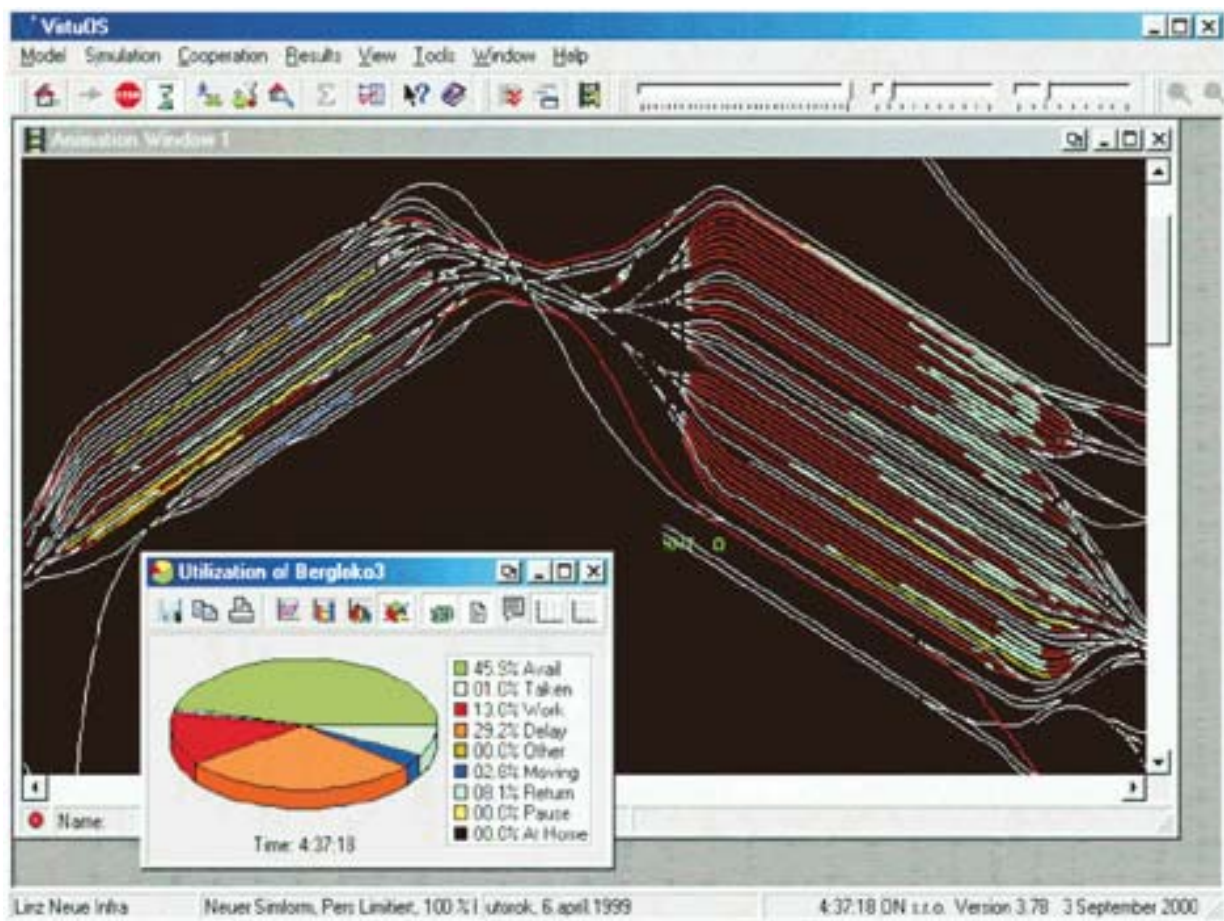

Both these layers are operating on entities. *Entities* are modelling elements of the real world and can be divided into *physical entities* and *information entities*. Physical entities are models of individual elements of the modelled system. Information entities concentrate information which is not bound to physical entities (are not their attributes) but which is necessary for the system control.

Simulation tool

As a research activity of the Faculty of Management Science and Informatics (partially sponsored by SBB Bern) a universal and detailed simulation model of transport node and its technological processes using ABASim architecture was developed. This model is understood as a tool which allows the user to examine all properties of an existing or just designed transport node in virtual (computer) environment instead of a real one. Transport nodes can be e.g. marshalling yards, stations for passenger transport, industrial sidings, container terminals, port terminals or ground traffic at airports.

The system is fully interactive and allows player's participation in decision-making. Running processes are animated and are shown on a precisely modelled node infrastructure. Here are some examples of problems which can be effectively examined by this

tool: designing optimal node infrastructure, development and verification of technological procedures, optimization of structure and usage of resources, examining impact of changes in surroundings on capacity and organization of transport node, training of dispatchers.

Projects

Simulation software based on ABASim was successfully used in this simulation studies:

Linz VBf Ost

Concentration of train forming activities from Linz region into the yard Linz VBf Ost after its essential reconstruction

Wien ZVBf

Concentration of train forming activities from Vienna region into the yard Wien ZVBf

Hamburg Alte Süderelbe

Verification of the changed infrastructure connected with the planned increased rate of train flow

Hagen Vorhalle

Technical modernisation of the yard Hagen Vorhalle

Oberhausen-Osterfeld

Technical modernisation of the yards

Lausanne Triage

Concentration of train forming activities from Lausanne and Geneve region into the yard Lausanne Triage

Basel Muttentz I

Technical modernisation of the yard connected with the planned increased rate of train flows

Mudanjiang (China)

Economisation of the operation of Mudanjiang marshalling and passenger station

Harbin (China)

Revision of efficiency of service processes

Žilina-Teplička

Simulation of a new operation within the new designed yard

BASF Ludwigshafen

Simulations of factory sidings processes within BASF

Volkswagen Bratislava

Simulations of factory transportation concept

SCA Laakirchen

Verification of the changed operation connected with the planned increased rate of transportation flows

References

- [1] KAVIČKA A., KLIMA, V.: *Simulation as a Support for Infrastructure Design and Planning Processes in Railway Junctions*. In: Proceedings of the Seventh International Conference COMPRAIL 2000, 11-13 September 2000, Bologna, Italy.
- [2] KAVIČKA, A., KLIMA, V., NIEDERKOFER, A., ZAŤKO, M.: *Simulation Model of Marshalling Yard Linz Vbf (Austria)*. In: Proceedings of The International Workshop on Harbour, Maritime and Logistics Modelling and Simulation, SCS Genoa, Italy, pp. 317-320, 1999.
- [3] KLIMA, V., KAVIČKA, A., ADAMKO, N.: *Software tool VirtuOs - simulation of railway station operation*, In: Proceedings of European simulation multicongress, SCS, Prague, 2001, pp. 84-88.
- [4] KAVIČKA, A., KLIMA, V.: *Simulations of railway station operation*, In: Proceedings of the World congress on Railway Research, Köln, Germany, 2001, The proceedings on CD-ROM.

Miroslav Hrnčiar

INTEGRATED NETWORK OF RTD ACCOMPLISHMENT

Department of Software Technologies, Faculty of Management Science and Informatics

The project IC 15-CT98-1003 IncoCopernicus - IntAccomp, was solved in the years 1998-2000 by the research workers mainly from the Faculty of Management Science and Informatics. The project was aimed at providing a uniform database structure and access methods across the interested countries (F, E, CZ, P, H, R, SK, LT, LV) which can promote exchange of information and support integration of the RTD community into the research structures of the European Union.

The second group of objectives was:

- to get evaluations of CE countries with respect to RTD as well as to socio-economic development;
- to get evaluations of relations between socio-economic conditions and RTD;
- to propose and investigate the methodology for such evaluations and its visualisation;
- to examine data analysis methods.

The research method applied by the Slovak partner involved the following activities:

- using some searching engines available on Slovak sites (Intranet of the University of Žilina);
- development and implementation of SQL interface tool for conversion of the data from national RTD databases to the IntAccomp data structure;
- co-operation in the testing process of the replication systems;
- design of a unified template for Success stories;

- development of a tool for questionnaires distribution, merging and presentation via Internet;
- co-operation in the socio-economic analysis of the RTD data from interested countries.

Methodology for socio-economic analysis

An approach based on a cluster analysis method has been used. According to the definition of distance calculation between clusters and distance calculation between objects, different methods based on the mentioned algorithm can be obtained. The distance between two objects was calculated as the square of Euclidean distance between two vectors, which correspond to these objects. A calculation came out from an average of distances between each object of the first cluster and each object of the second cluster.

In this task, z-transformation was used for the data regulation. To determine the criteria on the basis of which the clusters differ most each from other, the average values and standard deviations of the objects in individual clusters ($E_1, E_2, E_3, S_1, S_2, S_3$) were calculated. The parameter E_j is an average value of the criterion j and S_j is a standard deviation of the criterion j .

$$\frac{\sum_{j=1}^m \sum_{k=1}^m |E_j - E_k|}{\sum_{j=1}^m S_j}$$

For each parameter a "segregation coefficient" was calculated. The bigger the segregation parameter the better the clusters which are distinguishable by means of the given criterion. In this way the criterion which represents this criterion in the best way or which mostly influences the distribution of objects into clusters can be determined.

On the basis of the methodology mentioned above clustering to groups according to socio-economic criteria, criteria oriented to R&D, or the common criteria for both approaches was carried out. The weights of all the 19 criteria were considered to be equivalent. In the following step, by the means of the Statgraphics software tool, a cluster analysis was realized - distribution of objects (participating countries in the project IntAccomp) into three groups as well as identifying of relevant criteria. A Centroid method was used, distance metric - Squared Euclidean. Three different combinations of criteria were used:

- according to criteria 1-19 - all criteria, i.e., socio-economic as well as R&D ones
- according to criteria 1-6 - selected criteria oriented to general socio-economic characteristics of a country
- according to criteria 7-19 - criteria oriented to an R&D community.

Some results and conclusions

The data accumulated during the lifetime of the project as well as from success stories of a number of national enterprises were used to obtain some general conclusions. Thanks to the multinational character of the project, some conclusions can be proved to be nation-specific while others are (possibly) universally valid.

Having used a cluster analysis, the following results were obtained (see Tab. N°1).

An impact of criteria on distribution into clusters can be scored according to a value of a segregation coefficient. Values of this coefficient for individual criteria are in Tab. N°2.

According to this table, the criteria which have a crucial impact on the distribution to clusters can be named in the following order: 8, 7, 1 and 4. The Figures N°1 a N°2 present the results of mutual dependence on the most relevant criteria 7 - 8 and criteria 1-4.

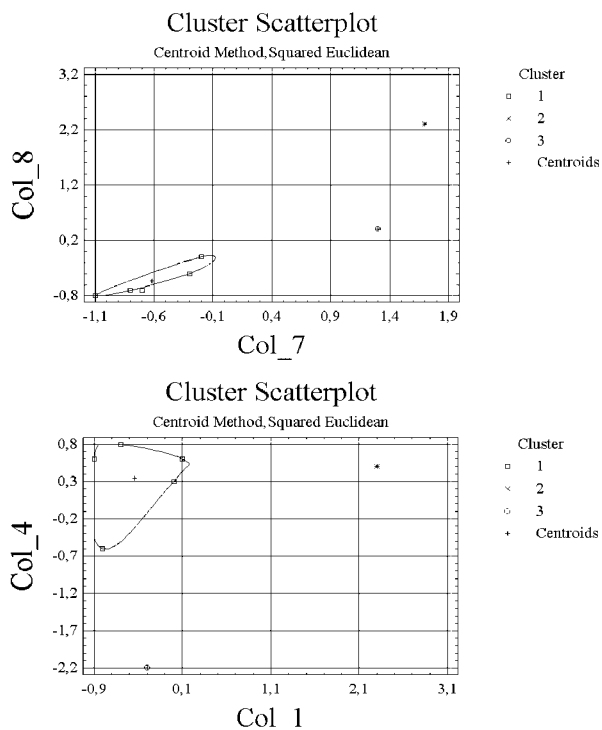

Figs. 1, 2: Distribution to clusters according to the criteria

References:

- [1] HRNČIAR, M., KOVÁČIKOVÁ, T., MATIAŠKO, K., HRKÚT, P., KAZDA, J: *IntAccomp Technical Reports SK Serie, N°1-8, 1998-2000*
- [2] KOLÁŘ, J., HRNČIAR, M.: *Actual Trends in Research Information Systems (RIS) Construction*, příspěvek na medzinárodnej konferencii I&IT, Banská Bystrica, 1999
- [3] HRNČIAR, M., ŠKVAREK, O: *Cluster Analysis for the Communication Quality Evaluation*, MI 2000, Conference of the Faculty of Management Science and Informatics, September 2000, Žilina

Tab. No1 - Results of Cluster analysis

Clustering according to the criteria	Clusters			The most relevant criteria
	1	2	3	
1 - 6 Socio-economic	CZ, HU, LV, LT, SK	PL	RO	Number of researchers,
7 - 19 RTD	CZ, HU, LT, SK	LV, RO	PL	Total number of employees,
1 - 19 General criteria	CZ, HU, LV, LT, SK	PL	RO	Gross domestic product in industry and services, Gross domestic product at current prices

Tab. No2 - Values of segregation coefficient

Criteria	1	2	3	4	5	6	7	8	9	10	11	12	13	14	15	16	17	18	19
Segregation coefficient	13.0	5.2	7.0	11.2	4.5	7.4	14.2	22.0	8.2	6.7	1.5	1.8	2.1	3.3	6.2	5.8	2.1	2.8	6.4

Ondrej Bartl

MODELLING OF DECISION PROCESSES UNDER RISK

Department of Software Technologies, Faculty of Management Science and Informatics

This part of scientific research activities of the faculty is represented by models building in the area of sequential decision making in an environment of risk for cost-effective operations management in manufacturing and services. The set of Markov and semi-Markov decision models built for inventory control problems together with optimization techniques from the theory of Markov decision processes provides efficient tools to determine cost-optimal policies for taking control actions in replenishment orders placement properly. Such an approach allows finding out control rules in single-item periodic-review inventory systems, where demand between consecutive reviews is a discrete random variable with either a finite or an infinite set of possible values. Review intervals between successive decisions on replenishment orders made at decision epochs when the current inventory position is reviewed specified a fixed duration. Discrete-time Markov decision models with finite state and action spaces were built for an optimal policy determination in periodic-review inventory systems with finite demand to handle alternatives with zero delivery lag both with [1, 2] and without [2] backlogging of demand as well as with positive (one review-interval) delivery lag with demand backlog [2]. If demand is represented by a Poisson process, then the set of possible values for demand size during a review interval in a periodic-review inventory system is infinite. This case was treated by a discrete-time Markov decision model with finite state and action spaces, when the cost structure reflects ordering, holding, shortage and rejection costs associated with the inventory system operation [3, 4, 5].

An inventory system where demand is represented by a Poisson process and delivery lag is a random variable depending on the quantity ordered, belongs to the class of stochastic discrete event dynamic systems. Decisions on replenishment orders are made at time points of discrete event occurrences. The corresponding semi-Markov decision model with finite state and action spaces were built [6, 7] for the optimal policy determination in stationary demand, delivery and financial conditions of the single-item inventory system operation. Some inventory systems require placing joint orders for two items. To find an optimal inventory control policy for such situations, the semi-Markov decision model with vector state and action spaces and finite sets of possible values of state and action variables were built [8]. Mutually independent Poisson process was considered to represent demand for particular items. The lead-time between the joint order placement and the corresponding joint delivery receipt was given by a longer time period of both individual random delivery lags dependent on the order size.

The problem when to dispatch a service car on a round trip to serve customers in the attraction area of a service centre is a problem

of sequential decisions made in an environment of risk if requirements for service form a Poisson arrival stream. A cost-effective control policy can be found using the semi-Markov decision model [9], where state and action variables range within finite sets of possible values.

Traffic control in the road lane closure case can be represented by sequential decisions on the number of vehicles released to move through the closure sector. Decisions are made by turns for one and the other direction with respect to the current situation in the queues of vehicles waiting on the road at both ends of the closure sector. To reveal an optimal traffic control policy, the semi-Markov decision model was built [10], where the sets of possible values for state and action variables are finite and vehicles are supposed to arrive in front of the closure sector in accordance with mutually independent Poisson processes.

The aforementioned decision models for dynamic operations management under risk were designed in the framework of the stochastic part of research projects "A Design and Operating Optimization of Logistical Chains" (in years 1997-1999) and "Models and Economic Optimization of Logistical Systems" (in years 2000-2002). The projects were supported by the Scientific Grant Agency of the Ministry of Education of the Slovak Republic and the Slovak Academy of Sciences under grants no. 1/4328/97 and 1/7211/20.

References:

- [1] BARTL, O.: *Decision Processes in an Environment of Risk*. In: Proceedings of the 17th International Conference on Mathematical Methods in Economics. Jindřichův Hradec, 14-16 Sept. 1999. Czech Society for Operations Research & University of Economics in Prague, Prague, 1999, pp. 11-18
- [2] BARTL, O.: *Inventory Control Markov Decision Models*. In: Second Scientific Conference „Effective Transport, the Way to European Union“. Section: 1. Transport Management, Marketing and Transport Policy, 2. Technology, Logistics and Informatics in Transport. Proceedings. Pardubice, 16-17 Sept. 1999. Jan Perner Faculty of Transport, University of Pardubice, Pardubice, 1999, pp. 371-376
- [3] BARTL, O.: *Cost Effective Control Policy for a Periodic-Review Inventory System*. In: Studies of the Faculty of Management Science and Informatics - University of Žilina, Volume 8. University of Žilina, Žilina, 1999, pp. 13-23
- [4] BARTL, O.: *Sequential Decision Making in Periodic-Review Inventory Control*. In: Proceedings of the 18th International

- Conference on Mathematical Methods in Economics. Prague, 13–15 Sept. 2000. Czech Society for Operations Research & University of Economics in Prague, Prague, 2000, pp. 1–6
- [5] BARTL, O.: *Ekonomicky efektívne riadenie zásob v podmienkach rizika. / Cost-Effective Inventory Control under Risk.* In: Communications - Scientific Letters of the University of Žilina, Vol. 2, 2000, No. 4, pp. 16–28
- [6] BARTL, O.: *Inventory Control under Risk with Discrete Event Dynamics.* In: Proceedings of the 19th International Conference Mathematical Methods in Economics. Hradec Králové, 5–7 Sept. 2001. Czech Society for Operations Research & University of Economics in Prague, Prague, 2001, pp. 7–12
- [7] BARTL, O.: *Sequential Inventory Control under Risk for Order Size Dependent Delivery Lags.* In: Studies of the Faculty of Management Science and Informatics – University of Žilina, Volume 9. University of Žilina, Žilina, 2001, pp. 1–17
- [8] BARTL, O.: *Joint Decision Making in Double-item Inventory Control under Risk.* In: Proceedings of the 20th International Conference Mathematical Methods in Economics. Ostrava, 3–5 Sept. 2002. Czech Society for Operations Research & Czech Econometric Society & Faculty of Economics, Technical University of Ostrava, Ostrava, 2002, pp. 7–18
- [9] BARTL, O.: *Round Trip Departures to Serve Customers under Risk.* In: Proceedings of the International Conference on Quantitative Methods in Economics (Multiple Criteria Decision Making X). The High Tatras, 30 Nov. – 2 Dec. 2000. Slovak Society for Operations Research & University of Economics in Bratislava, Bratislava, 2000, pp. 5–10
- [10] BARTL, O.: *A Traffic Control Decision Model in the Road Lane Closure Case.* In: Quantitative Methods in Economics (Multiple Criteria Decision Making XI). Proceedings of the International Conference. Nitra, 5–6 Dec. 2002. Slovak Society for Operations Research & Faculty of Economics and Management, Slovak Agricultural University in Nitra, Nitra, 2002, pp. 6–20

Štefan Hittmár – Jozef Strišš

SUPPORT AND DEVELOPMENT OF TRANSPORT MANAGEMENT

Department of Management Theories, Faculty of Management Science and Informatics

1. Methodology of Transport Strategy

The aim is to describe the methodology for creation and support of function strategy and business development in transport for 3 to 5 years period.

An objective scope of these activities is the development and purpose of transport business in conditions of the Slovak Republic in long-term horizon. Solution is mainly oriented on development of management, marketing, providing of transport services and related activities.

2. Training of Railway Management

In terms of the Conception of Railways of the Slovak Republic Management Education, we prepared training projects for low and middle management. The projects meet the need of scientific, functional and career growth of organisation employees.

The projects are divided into the following scientific modules: Management, Marketing, Finances, Controlling, Law, Quality Management. In term of specification the modules are created for employees of scientific units: Economics, Human Resources, Trade and Marketing and Operation.

The first year of training was held in the year 2001 and 314 attendants graduated, in the year 2002 there were 226 attendants.

3. Projects for Transport Management

Transport Process Management, co-operation with the University of Pardubice

The solution of the project is oriented on analysis and design of transportation processes rationalisation in the transport management. The aim of the solution is development of process management principles in transportation activities as the basis for a reengineering conception. Transportation processes will be radically renovated and reconstructed in the way that will lead to the so-called step improvement of transportation processes in terms of costs, service quality and speed.

Content – the general solution scope is the identification of transportation processes in logistic chains with the focus on transport subsystem. The process choice will be oriented on right processes, it means the processes oriented on benefit of customers, contributing with added value.

Development strategy in railway transport

At present there is no suitable methodological material available for the processing of business activities development for quality transportation services. There are no theoretical and methodological procedures for this activity. It is necessary for the railway transport to continue in the general and formal development and to create conditions for successful operation on the transportation market.

The solution of the project is the long-term development of the business in railway transport in the conditions of the Slovak Republic. The solution is oriented on main potentials of business activities: human resources, economics, commercial activities and marketing, information resources, management system and organisational structure etc.

Solution results – methodical and methodological material can be used especially for preparation and formation of basic strategic documents for business in the field of services providing on competition-oriented transportation market.

Management in communication systems (KOM-MAN) – grant project VEGA

For management in the field of communications (information, communication and transport systems), there are not any management bases elaborated. Apart from practical experience and references, it is necessary to deal with theoretical management base in the market economy.

The scientific project deals with an important and topical problem of information, communication and transport processes management from the point of view of economic science. The project analyses present management methods in those systems home and abroad, reviews internal and external conditions and formulate scopes for scientific base creation, the so-called *communication management* (subject, basic explanations, conceptions and definitions of research). On the basis of these analyses, the project defines and develops management methods, models and techniques used in complex conditions of communication systems and designs chosen algorithms of solution for structured and non-structured communication management tasks.

The project contributes to development of management knowledge base in communication systems (communication management).

Project: Networks of Excellence: “Railway Wheel Sets, Safety, New Materials and Technologies, Ecology, Law, Economy”, Silesian University of Technology in Katowice (Proposal for our participation in the Network of Excellence activities within the Sixth Framework Programme of the European Community for research, technological development and demonstration activities.)

We are planning the following activities aimed at disseminating of knowledge of the project:

Conferences and seminars:

- International seminars: Management in the railway transport – 2003
- International seminars: Management in the railway transport – 2004
- International conference on railway administrations agents from CEEC

Education:

- Educational project for the Slovak railway management – during 2003 and 2004

Projects:

- Decision Support Tool for Marshalling Yard Location
- Spatial Decision Oriented Intelligent System for Transport and Distribution Service Design

- Methodology of business activities development strategy in railway transport
- Motivation accent of human resources management processes
- Quality in process of customer relationship management

References:

- [1] HITTMÁR, Š., STRIŠŠ, J.: *Management and Marketing in the Railway Transport*. – scientific publication – monograph ŽSR a ŽU, (15,07 AH – 202 pages). Žilina: University of Žilina, 1997. ISBN 80-7100-403-0.
- [2] HITTMÁR, Š. et al.: *Management in Transport* – scientific publication – monograph ŽU, (18,11AH – 318 pages). Žilina: University of Žilina, 2001. ISBN 80-7100-784-6.
- [3] HITTMÁR, Š.: *Strategic objectives for railway system*. Scientific article. In: Proceedings of 6. International Symposium Žel ‘99 – Railways on the doorstep of the third millennium, Faculty of Management Science and Informatics at the University of Žilina, Žilina 1999. pp. 156-160. ISBN 80-7135-053-2.
- [4] HITTMÁR, Š.: *Strategic management in railway transport*. Scientific article. In: Proceedings of scientific seminar Management in railway transport ‘99. Žilina: Faculty of Management Science and Informatics at the University of Žilina, 1999. pp. 11-22. ISBN 80-7100-639-4
- [5] HITTMÁR, Š.: *Quality management in transport as service*. Scientific article. In: Proceedings of scientific seminar Management in railway transport ‘99. Žilina: Faculty of Management Science and Informatics at the University of Žilina, 1999. pp. 101-107. ISBN 80-7100-639-4.
- [6] HITTMÁR, Š.: *Services of railway freight transport* In: Proceedings of scientific seminar Management in railway transport 2000. Žilina: Faculty of Management Science and Informatics ŽU, Žilina 2000. pp. 29-31. ISBN 80-7100-764-1.
- [7] HITTMÁR, Š.: *Services of railway personal transport*. Scientific article. In: Proceedings of scientific seminar Management in railway transport 2000. Žilina: Faculty of Management Science and Informatics ŽU, Žilina 2000. pp. 32-36. ISBN 80-7100-764-1.
- [8] HITTMÁR, Š.: *Management model in transport*. Scientific article. In: Proceedings of scientific conference Transport within the globalisation times. Praha: Transport faculty ČVUT Praha., 2001. pp. 24-28. ISBN 80-01-02350-8.
- [9] HITTMÁR, Š.: *Management model in railway transport*. Scientific article. In: Proceedings of 7. International Symposium Žel 2000 – Railways on the doorstep of the third millennium Žilina: Faculty of Management Science and Informatics at the University of Žilina, 2001. pp. 73-78. ISBN 80-7135-055-9.
- [10] HITTMÁR, Š.: *Management in transport – scientific discipline?* Scientific article. In: Proceedings of conference Science about transport. Praha: FD ČVUT Praha, 2001. pp. 20-28. ISBN 80-01-02437-7.
- [11] HITTMÁR, Š.: *Methodology of organisation strategy creation*. Scientific article. In: Proceedings of international scientific conference Perspectives and needs of management in 21. century-section 2. Ostrava: Economic faculty VŠB TU Ostrava, 2002. pp. 24-31. ISBN 80-248-0187-6.

Books issued by the Faculty within the period 1998-2002

- Martin Fronc: KVANTITATÍVNE METÓDY (TEÓRIA HIER A TEÓRIA GRAFOV) - Quantitative Methods (Game Theory and Theory of Graphs)
- Miroslav Benedikovič et al.: PRÁCA V INTERNETE A INTRANETE - Work in Internet and Intranet
- Štefan Hittmár: PLÁNOVANIE V MALOM A STREDNOM PODNIKANÍ - Planning in Small and Middle Business
- Jaroslav Janáček: MATEMATICKÉ PROGRAMOVÁNÍ - Mathematical Programming
- Martin Klíma et al.: ŠIROKOPÁSMOVÉ SIETE - Broadwidth Networks
- Jaroslav Král: LOGISTIKA, RIADENIE DODÁVATEĽSKÝCH REŤAZCOV - Logistics, Supply Chain Management
- Štefan Hittmár: MANAŽMENT V DOPRAVE - Management in Transport
- Ludmila Jánošíková: PROGRAMOVANIE V JAZYKU SYMBOLICKÝCH ADRIES PRE 32-BITOVÉ PROCESORY INTEL - Assembly Language Programming for 32-bit Intel Processors
- Valent Klíma: ÚDAJOVÉ ŠTRUKTÚRY - Data Structures
- Dušan Marček: ANALÝZA, MODELOVANIE A PROGNOZOVANIE ČASOVÝCH RADOV - Analysis, Modelling and Prognosis of Time Sequences
- Karol Matiaško: DATABÁZOVÉ SYSTÉMY - Database Systems
- Jaroslav Janáček: OPTIMALIZACE NA DOPRAVNÍCH SÍTÍCH - Optimization in Transportation Networks
- Martina Blašková: RIADENIE LUDSKÝCH ZDROJOV - Management of Human Resources.



FACULTY OF SPECIAL ENGINEERING

FACULTY OF SPECIAL ENGINEERING

Ul. 1. mája 32, 010 26 Žilina
Phone: +421-41-7633320, 5620477, 7233613
Fax: +421-41-7234972
E-mail: dekanfsi@fsi.utc.sk

Academic officials of the Faculty:

Dean:

Prof. Ing. Pavel Poledňák, PhD.
Phone: +421-41-7233613
E-mail: polednak@fsi.utc.sk

Vice-Dean for education:

Assoc. Prof. Ing. Zdeněk Dvořák, PhD.
Phone: +421-41-7233613
E-mail: dvorak@fsi.utc.sk

Vice-Dean for research and science:

Assoc. Prof. Ing. Jaroslav Slepěcký, PhD.
Phone: +421-41-7233613
E-mail: slepecky@fsi.utc.sk

Vice-Dean for development and foreign relations:

Assoc. Prof. Ing. Stanislav Štofko, CSc.
Phone: +421-41-7233613
E-mail: stofko@fsi.utc.sk

The Faculty of Special Engineering of the University of Žilina was transformed from the Military Faculty of the University of Žilina. The previous faculty was established in 1952 and, at this time the Faculty was constituted as the Railway Faculty and a part of the Military Technical University in Brno, the Czech Republic. In 1953 the Railway Faculty was relocated to the Railway University in Prague, the Czech Republic and renamed the Military Faculty. This Military Faculty was in 1959 transferred to Žilina and became a part of the newly established Technical University of Transport. Today's name of the university is the University of Žilina.

Under the authority of the Ministry of Transport, Posts and Telecommunications of the Slovak Republic, the Ministry of Education of the Slovak Republic, the Ministry of Defense of the Slovak Republic, the Accreditation Committee of the Government of the Slovak Republic and by acclamation of the Academic Senate of the University of Žilina, the Military Faculty was on 9th February 1998 renamed to the Faculty of Special Engineering of the University of Žilina.



The Departments of the Faculty:

- Department of Crisis Management,
Phone: +421-41-7633320, E-mail: horacek@fsi.utc.sk
- Department of Fire Engineering,
Phone: +421-41-7633320, E-mail: olsar@fsi.utc.sk
- Department of Security Management,
Phone: +421-41-7633320, E-mail: reitspis@fsi.utc.sk
- Department of Technical Sciences and Informatics,
Phone: +421-41-7633320, E-mail: seidl@fsi.utc.sk
- Department of Military Transport,
Phone: +421-41-7633320, E-mail: maca@fsi.utc.sk
- Off-campus Institute in Košice,
Phone: +421-41-6771379, E-mail: fsi_ke@stonline.sk

The Department of Crisis Management is the main department to offer studies in the field of civil security. These studies are oriented and designed for solutions of crisis situations. They aim at various spheres of public administration, at business and finance, at social and environmental backgrounds.

The Department of Fire Engineering is the main department to offer studies in the field of fire protection. The studies are technologically oriented toward fire prevention and repressive activities, emergency tasks and work of fire brigades.

The Department of Security Management is the main department to offer studies in the field of security management. The studies are technologically oriented and are applied to the subjects of safety of persons and property and of object protection.

The Department of Technical Sciences and Informatics is an inter-sectional department and provides education for all the study programs, mainly in technical sciences, logistics, transport techniques and technology, informatics, automation, designing of engineering tasks, health safety and security of work.

The Department of Military Transport is the main department to offer studies in the field of military transport and military construction. Military studies will end their study programs in the year 2004.

Educational Activities

Educational programs and research tasks of the Faculty have managerial and technological orientation. Educational programs are oriented to the problem of:

- *risk and crises management applied in economy, public administration, transport and environment,*
- *solution of universal questions of national and public security,*
- *fire protection,*
- *rescue services,*
- *integrated systems of safety of objects and property,*
- *safety services and protection of objects of special importance,*
- *security information systems.*

The faculty offers the university education in all three levels of university education in these study branches:

- *Bachelor level:*
 - *Civil Security, specialization Security Management*
 - *Fire Protection*
- *Engineering level:*
 - *Civil Security*
 - *Civil Security, specialization Security Management*
 - *Fire Protection*
 - *Military Transport and Military Constructions*
- *Ph.D. level:*
 - *Military Transport and Military Constructions*
 - *Transport Machines and Equipment.*

The FSI offers different forms of lifelong education for officers working in government, public administration and in the fields of economy and social life.

The main aim of the FSI is to provide comprehensive theoretical and practical education, language skills and professional knowledge.

Currently FSI has 41 teachers, therefrom are five professors, 11 associate professors, 18 lecturers and seven assistants. The FSI employs four research workers and 15 clerks.

Tasks in educational activities

The goals of the FSI in the educational field for the near future are:

- *to prepare new study programs for accreditation,*
- *to make study programs more attractive,*
- *to offer new study subjects for students of other faculties of the University,*
- *to build special laboratories and to use new methods of e-learning.*

Research and science activities

The research and scientific work of the Faculty is oriented to solve problems related to the crises events in different spheres of social, natural and economic environment. Further, the research work is oriented to solve questions related to defense, civil security and inhabitants and property safety.

The main attention in research and science activities is given to:

- *solve theoretical and fundamental crisis management problems,*
- *investigate basic, the organizational and structural problems of crisis management in public administration,*
- *risk analyses and designing preventive actions,*
- *solve crises situations occurring in nature, economy and society,*
- *fire engineering, mainly to fire prevention and fire-stopping technology,*
- *solve live tasks in the frame of complex emergency system, to innovate the technology and technical means in fire protection,*
- *fire security of road tunnels and constructions,*
- *technical safety and fire protection of buildings and other facilities,*
- *solve tasks related to security protection of people, property and equipment,*
- *methods and technique of safety management,*
- *integrated safety systems,*
- *solve specific tasks in military logistics, oriented to military constructions, military transport,*
- *develop the transport infrastructure problems and to solve transport problems in crises situations.*

The Faculty teachers and researchers are involved in many scientific, research and expert tasks solutions through domestic or foreign grant agencies. They co-operate also with foreign partners on several international projects in various fields of risk and crises situations solution, in people and property safety and security.

SAFETY METHODS AND STANDARDS OF CLASSIFIED REALITIES PHYSICAL SECURITY

The study Safety Methods and Standards of Classified Realities Physical Security is the result of the Department of Security Management members work. It is a result of comparison of present attitudes to security standards of physical security creation and object security in the Slovak Republic but also in the Czech Republic, Poland, Germany and Austria. Some ideas found in NATO standards are also included in the study.

1. Solution description

Standards of physical security and object security (further only security standards) are instruments which can fulfil the following functions:

1. Complex and list of measures for object security in which classified realities are.
2. Basic document for audit of object security state in which classified realities are.

When formulating the security standards the following approaches are used:

1. The exploitation of points assessment method for object security state.
2. The exploitation of protection measures division method into depth with priority of time factor assessment.
3. List of required measures for objects' security according to their category and category of protected area.

Points assessment method can be used within security standards of object (physical) security in the Czech Republic. The list of security standards is divided into six basic spheres of protection measures. Protection measures in these spheres are point assessed and sum of point assessments of realised measures in these spheres functions as a standard for assessment of physical security quality.

According to the authors of this security standard, the security standards are designed as instructions for security risks management in a form of options enabling selection of the most suitable and financially the most effective combinations of security measures for security of classified information against illegal manipulation.

Assessment of time factor method is used in the document NATO C-M (2002)23 Annex „D“ Physical Security.

This document deals with information that program of physical security exploits the principle of “protection into depth” whose goal is to achieve the required slowdown of intruder advance.

Outer layers of physical security define as protected area and prevent illegal access into it.

The next layer detects an illegal access or an illegal access attempt and creates alarm signal for activation of guard-duty. The inside layer slows down the intruder's advance and creates time space for a guard unit to catch him. In case of physical that has been projected in this way, there is a clear relation between response time of guard - duty (T_{RO}) and slow-down time, which is caused by the system of mechanical blocks (T_S). It is necessary to fulfil this condition:

$$T_{RO} < T_S$$

Substantial condition for this method's application is installation of Intruder Detection System.

The Standard measures method is used in security standard of physical and object security, which is valid in the Slovak Republic, as well as in minimal standards for storage of the NATO classified information (*Minimum Standards for the Storage of the NATO Classified Information*) - annex D to C-M(2002)23, in *IT-Grunschutzhandbuch, Standard-Sicherheitsmaßnahmen*, which was issued by Federal Office for Security - BSI (Bundesamt für Sicherheit in der Informationstechnik), in *IT-Sicherheitshandbuch für die öffentliche Verwaltung*, which was issued by the Federal Ministry for Public Administration and Sport (Bundesministerium für öffentliche Leistung und Sport - BMÖLS) and in Poland, measures result from Act. from 22nd of January 1999 on protection of classified information (*Ustawa o ochronie informacji niejawnych*).

Working out of security standards, which will be used to provide the security of classified information is a result of this study. The structure of suggested security standards enables to create a variant system of protection measures according to local conditions (according to dislocation or object structure, according to risks and threats evaluation) by meeting requirements described in the Act No. 241/2001, as well as in the promulgation No.88/2002.

The system of protection measures is integrated into the following basic layers:

- Measures of external (perimetric) protection.
- Protection of object borders.
- Protection of protected space borders.
- Inside protection of protected space.

Subgroups of protection measures are chosen for security of protection measures, in particular, layers by exploitation of:

- mechanical blocks (MB),
- technical security facilities (TSF),
- physical protection.

Range and quality of the used MB, TSF used or usage of physical protection depend on the results of an object and protected area categorisation as well as on internal code in object or protected area (continuous presence of persons, rights of guard`s competence and so on are taken into account).

The gist of this attitude to projection of security standards is to enable creation of functional, effective and from financial point of view optimal protection system of classified information.

Point method was used for quantitative assessment of protection measures sufficiency. Depending on the existing conditions, this method enables to select such a combination of protection measures which fulfils the determined conditions most. The access algorithm to the selection of protection measures is illustrated in Fig. 1.

Minimal point values are determined for objects and protected spaces. These values must be achieved for a chosen degree of security of classified information. These point values were achieved by assessment of protection measures which are described in particular layers of object protection and protected space and

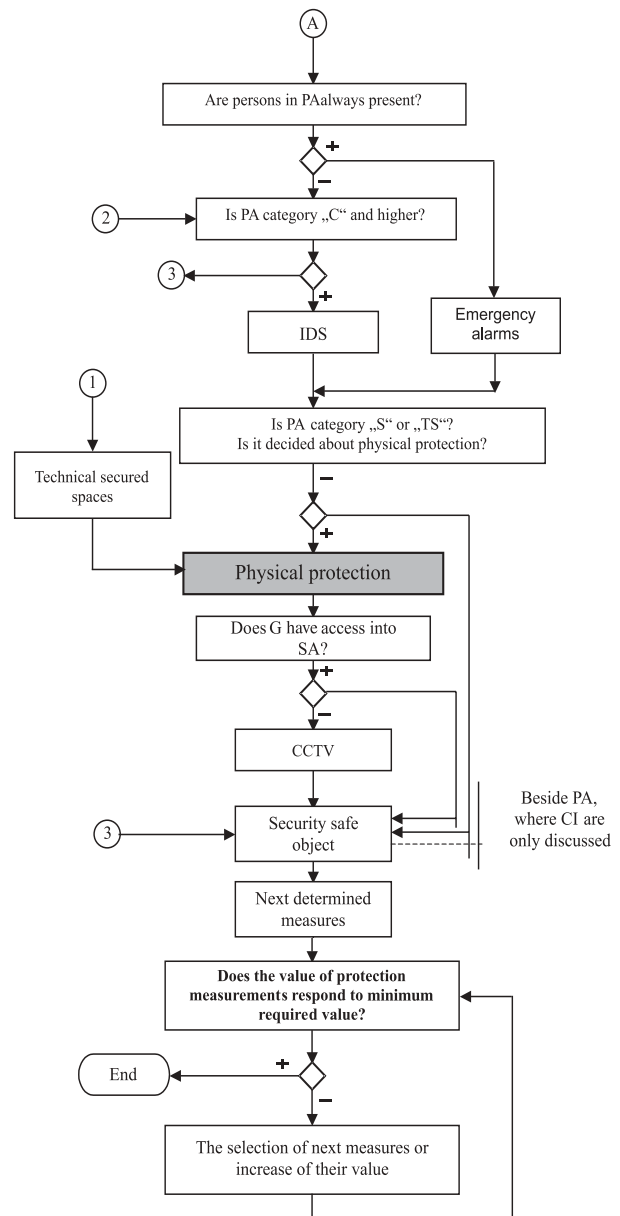
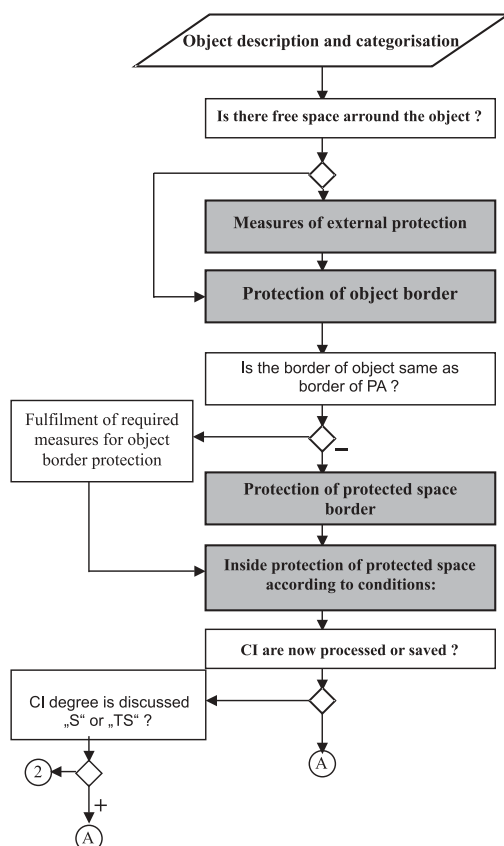

Explanatory text:

- CCTV - Camera set (Closed Circuit Television)
- PA - Protected Area (Security Area or Restricted Area)
- C - Degree of security (Confidential)
- IDS - Intruder Detection System
- G - Physical protection (Guards)
- S - Degree of security (Secret)
- TS - Degree of security (Top Secret)
- CI - Classified Information

Fig. 1. Algorithm suggestion for selection of security standards

they are from law regulations requirements (for the security of classified realities protection) defined as obligatory measures.

Furthermore, also next recommended measures are defined for the security of classified information protection security. When using these measures it is possible to achieve an increase of level of classified information protection. The chief or his deputy (security worker or worker of special workplace) decides on their usage according to results of the security risks analysis. These measures are described separately and they are not point assessed.

2. Results applied in practice and in education

The study was worked out following the requirement and order of National Security Office. It is determined to work out and assess standards for provision of physical and object security on those places, where classified information is found (stored, processed). Recommendation processed suggestions can be used for revision of current law standards and regulations for classified realities protection.

The methods and approaches used in a process of security standards preparation but mainly information obtained from their creation and application in other states will be also used in further research works in the sphere of risk security analyses.

Study results and information obtained are also available for the sphere of education in the Security Management specialisation.

References

- [1] Zákon č. 241/2001 Z. z. o ochrane utajovaných skutočností a o zmene a doplnení niektorých zákonov.
- [2] Vyhláška NBÚ č.88/2002 Z. z. o fyzickej bezpečnosti a objektivej bezpečnosti.
- [3] Bezpečnosť v rámci organizace Severoatlantické smlouvy (Security within the North Atlantic Treaty Organization). Dokument C-M (55) 15 (Final/konečná verze)
- [4] C-M (2002) 23. Annex 1, Enclosure „D“. Physical Security.
- [5] Zákon č. 148/1998 Sb. o ochrane utajovaných skutočností a o zmene niektorých zákonů (ČR).
- [6] Vyhláška NBÚ (ČR) č. 339/1999 Sb. o objektivej bezpečnosti.
- [7] Bezpečnostní standardy objektivej (fyzickej) bezpečnosti. Věstník NBÚ ČR, 2001.
- [8] IT - Sicherheitshandbuch für die öffentliche Verwaltung. BMÖLS, Österreich, 1998.
- [9] IT - Grundschriftshandbuch. BSI, Deutschland, 2001.
- [10] Ustawa z dnia 22 stycznia 1999 r. o ochronie informacji niejawnych.

Miloslav Seidl – Lenka Rošteková

QUALITY OF EDUCATION IN THE FIELD OF TRANSPORT LOGISTICS AND ITS MANAGEMENT

1. Description and principles of education

The project called “The Quality of Education in the Field of Transport Logistics and its Management” was registered, accepted and financially supported by the Cultural and Educational Agency of the Ministry of Education of the Slovak Republic till the time of its completion in the year 2002.

Logistics is a relatively new and perspective field of science and research of the present-day Department of Technical Sciences and Informatics. In recent years this discipline has become an integral part of all study programs realised at the Faculty of Special Engineering. The purpose of the project was to create a model of logistics education in general and specifically of transport logistics.

The basis of this project solving was a fact that the training of logistics and transportation logistics specialists is carried out simultaneously in several educational institutions. Traditional fields of study and sciences focussing on technology of individual kinds of transport form the base of the present-day education. Till the present time less attention has been paid to the impact of factors with high amount of risk on transport logistics principles application in crises situations.

The fundamental principle of this project solution was organisation of regular meetings of experts working in the sphere of education, science, research and practice with focus on highly specialised points of issue combined with interpretation of new information and with publication of monothematic outputs in a form of reports. Another purpose of this project solving was a creation

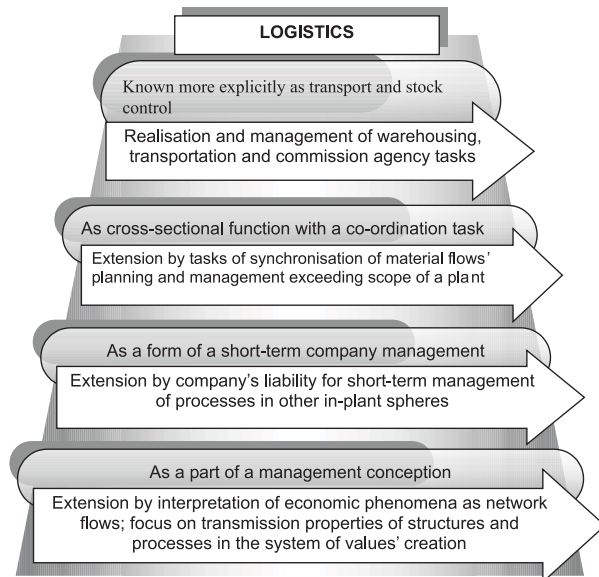

Fig. 1. Development of term logistic

of integrated study fund for university preparation of professionals working in the sphere of transportation logistics that could be used in broader context in various forms of life-long education.

2. Application of results in practice, education, and follow-up research

The most significant results achieved after this project's solving:

- Incorporation of the subject "Logistics" into compulsory subjects of all specialisations of the study fields "Civil Security" and "Fire Protection" and emphasis on this subject's importance by its higher assessment in a credit system,
- Equal position of Logistics in newly prepared study programs "Crisis Management of Transport" and "Security Management",
- Incorporation of the subject "Logistics" into alternative subjects of the doctorate study of the study field "Civil Security" and realisation of this subject's tutorial activities at the Faculty of Special Engineering,
- Incorporation of selected topics from the subject Logistics into lectures provided by the Faculty of Special Engineering at some other universities (FEM SAU Nitra, APF Bratislava),

- Teaching logistics grounds in a specialised education of the railway police personnel
- An offer of thematic tasks for graduation theses that would include solving of selected logistics' problems,
- Successful thesis defense of an external inceptor, which concerned points of issue of military transport,
- An offer of thematic tasks of doctorate study focussing on transportation logistics and admission of one internal graduant to solve these tasks
- Working out more than twenty papers on logistics' themes, which were presented at scientific conferences, including international ones,
- Organising conferences, dealing with logistics in transport topics, which included international participants,
- Publication of reports from conferences. These reports include the most important presentations.,
- Working on a textbook, expected year of its publication is 2003,
- Reinforcement and further development of co-operation between workplaces abroad, which focus on training and scientific work in the field of transportation logistics that would also include exchange programmes,
- To make use of the results when solving further scientific tasks:
 - Transportation Management in Crises Situations (project approved within Slovak-Czech co-operation),
 - Logistic provision of Evacuation (project approved and supported by Agency for Science and Technology ME SR)
 - Organisation of Railway and Road Transport in Case of Transport Route Impairment (project approved and supported by VEGA),
 - Methodology of Railway Transport Organisation in a Restricted Railway Space, which Originated by Transport Route Impairment (research project assigned and supported by MTPT SR),
 - Transport Provision in Case of Crises Situations and Creation of a System of Crisis Management in the department of MTPT SR (research project assigned and supported by MTPT SR).

References:

- [1] SEIDL, M.: *Úvod do logistiky* (1.časť). VF VŠDS, Žilina, 1993
- [2] SCHULTE, Ch.: *Logistika*. Victoria Publishing, Praha, 1994
- [3] SEIDL, M.: *Protokol o ukončení riešenia projektu KEGA*. FŠI ŽU, Žilina, 2003

Stanislav Štofko – Jacek Binda

BILATERAL CO-OPERATION PROJECTS IN THE SLOVAK – POLISH BORDER

The University of Žilina is a sympathetic member of the Community Association and another subjects of the Euroregion Beskydy, whose goal is particularly the bilateral co-operation development.

The region of Euroregion Beskydy represents the border region among Slovakia, Poland and Czech Republic with the centres in Žilina, Bielsko – Biala and Frýdek – Místek. Until the constitution of the Euroregion the international co-operation was on the level of self governed units based first of all on mutual relations of towns and villages. The idea of activation of international co-operation led the Lord Mayors and Mayors of the villages of Žilina Region to an interesting association of legal entities of the Beskydy Region. The association was founded in 1999 on the principle of voluntary membership, and was supported by the Regional Office in Žilina. The treaty of the Slovak-Polish Euroregion Beskydy was signed in the year 2000 and after mutual agreement was extended by the third part (the Czech Republic).

Euroregion Beskydy represents a territory covering the area of approximately 3,900 sq. km and with the population 780,000 inhabitants. Members of Euroregion are totally 133 partner villages and towns from Poland, Czech Republic and Slovakia (from Kysuce, Orava and Upper Povazie). From the Polish side e.g. Bielsko-Biala, Szczyrk, Żywiec, Jordanów; the districts Bielsko-country, Żywiec, Suski, from the Czech side Frýdek-Místek, Frýdlant nad Ostravicí, Šenov, Vratimov, Brušperk, from the Slovak side Bytča, Čadca, Kysucké Nové Mesto, Námestovo, Rajcecké Teplice, Turzovka and Žilina.

Six common expert groups are responsible for the project and its objectives. The main duty of the groups is identification of the possible ways of development of co-operation in particular fields. E.g. the section for tourist traffic, culture and sport continues in successful co-operation going on for several years under the name Beskydy without borders.

This lovely territory besides its favorable geographic setting, is characterized also with a quality of human potential with relatively high educational level and qualification structure, cultural niveau, abilities to economic co-operation, attractive natural settings with opportunities to winter sports, all-year-round tourism, thermal springs, and sufficient accommodation capacities for tourist traffic, and high afforestation of the territory.

The staff of the Faculty of Special Engineering and also the staff of Faculty of Operation and Economics of Transport and

Communications have been participating in the problem solution of border regions. The projects of international scientific-technical co-operation are being solved together with the Polish partner e.g. projects “Improvement of delivering transport, postal and telecommunication services in the border regions” and “Impact risks of some property taxes for the community financing.”

Some development aspects of the border regions are incorporated in the Economy development strategy of the Slovak-Polish border regions in years 2000–2006 that is made by Government centre of strategy studies.

In term of transport, for example the transmultimodal corridor Gdańsk – Poznań/Lodź – Žilina that knots to the corridor Terst – Bratislava – Žilina – Košice – Ukraine, creates good conditions for the economy activities development and for the territory development. The services improvement, in perspective of the common EU entry, is a resource to the border co-operation regions development.

Municipalities, which administer the local communication, contribute to the development of the transport infrastructure. Property taxes fall into important incomes of community budgets, their benefit covers a relevant part of community expenses. The participation in property taxes is directly dedicated to building, repairs and maintenances of local communications.

Property taxes, first of all immovable property tax dynamically create the community possibility to accommodate to the variant conditions and support opportunities for a dynamically business development in the community territory. Risk analysis dealing with property taxes in the Slovak Republic and Poland, and as well as their comparisons with some EU countries are being worked out.

References:

- [1] ŠTÁNSKY, P. ET AL: *Severozápadné Slovensko*. Žilina, Knižné centrum, 2002
- [2] ŠTOFKO, S.: *Euroregión Beskydy – cezhraničná spolupráca na česko-poľsko-slovenskom pohraničí*. Zborník medzinárodnej konferencie Ostrava: VŠB – TU, 2001.
- [3] ŠTOFKOVÁ, J., ACHIMSKÝ, K., ROSTÁŠOVÁ, M., ŠTOFKO, S.: *Program of economic and social activation of boundary areas..* Žilina, University of Žilina, 1998.

Crisis management in public administration

prof. Ing. Ladislav Šimák, PhD.

ISBN 80-88829-13-5, University of Žilina, 2001

The university textbook of Crisis management in public administration summarises the fundamental knowledge of theory of crisis management. The textbook acquaints the students with the history and origin of crisis management, defines the ground concept of theory of crisis management, determines operations, aims and tasks of crisis management and describes its institutional classification in public administration. In the textbook are also interpreted processes of prevention of crisis phenomena and principles, procedures and tools used at their solutions. The emphasis is laid on formation and implementation of crises strategies and on information protection of crisis management. The final chapter is devoted to economic crises, their impact on society and to possibilities of their solutions.

The textbook is written for students of daily and external forms of studies in educational specialisation of Civil security at the Faculty of Special Engineering of the University of Žilina. It is used also in education processes in other universities and in practice. The textbook is a basic vocational tool for crisis managers in public administration and in self-governments. It is used in the frame of various forms of lifetime education and in PhD studies.



Risk management

Prof. Ing. Jan Mikolaj, DrSc.

ISBN 80-88829-65-8

This monograph on risk management is a consequential publication to the previous textbook on Theory of risk issued at the Faculty of Special Engineering of the University of Žilina. The publication belongs to first-fruits on the professional Slovak book market. The risk question is narrowly connected with the behaviour of market economy but has much larger dimension. Risk is a part of social entity and so risk has to be identified in social environment as well as in existence and behaviour of every human being. Man and his activities run always over in specific natural and living environment where risk phenomena and occasions can be also found. The substance of risk consists in uncertainty of appearance and development of phenomena and has therefore causal characterization. Risk, that is not solved, directs toward crisis. The significance of every single risk is inevitable to be measured with adequate methods. Such methods shall be found, first of all, in their quantification and in probability of their appearance. Relevant methods are provided by mathematical analysis and calculus of probability.

This monograph is dedicated not only to academic students studying questions of safety and reliability systems but also to the wide range of practitioners who are dealing with risk tasks on professional level. It is a resource for further investigation of risk problems contained especially in observation of evolutionary characteristics of technology, economy and society development.

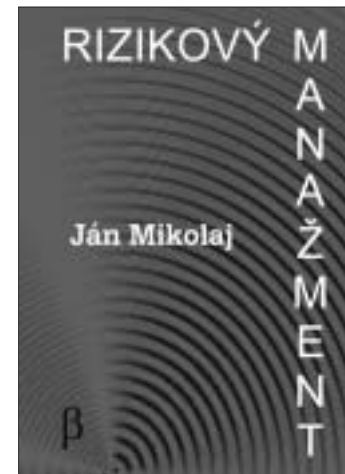



Crisis situations in railway building

doc. Ing. Jozef Reitšpis, PhD
doc. Ing. Jaroslav Slepecký, PhD
Ing. Marian Marcin, PhD

ISBN 80-88829-72-0, University of Žilina, 2003

This university level textbook gives the basic orientation in problems of renewal of railway tracks and objects of railway base during crisis situations. The structure and contents of the textbook is adapted to these problems. They are developed from the knowledge of extraordinary situations (war operations, floods, landslides, breakdowns of structure e.t.c.) It shows possibilities of different solutions in special conditions which can be assumed and shall be solved.

The textbook is written for students of master level study in the field of transport constructions. It deals with solution of crisis situations and securing of emergency work during crisis situations. The textbook utilizes contemporary laws and technical standards in mentioned fields such as renewal of railway tracks, objects of railway base in the frame of the Slovak Republic during crisis situations.



Building and technological preparation of constructions

Ing. Marian Marcin, PhD

ISBN 80-88829-55-0, University of Žilina, 2000

The textbook gives a principal orientation in preparation of transport construction realization. The premise of successful building and technological preparation from the point of view of a constructor is elimination of uneconomically slow and usually less rate ways of realizations. These depend on immediate free building devices and to them related time, technological and organizational structures.

The main contents of textbook forms building and technological preparation of constructions from the point of constructor maker. The accent is focused on building and technological projection of earth works in transport building. The text book is designed for engineering degree students of civil specialization, to building enterprises and to experts from practice.

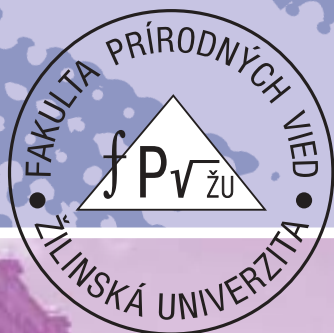

FACULTY OF SCIENCE

FACULTY OF SCIENCE

*Knowledge is but the struggle for knowledge.
And we are always equally far from and equally
near it.*

(Ramón Sender)

Hurbanova 15, 010 26 Žilina

Dean:

Assoc. Prof. RNDr. Miroslava Růžicková, CSc.

E-mail: ruzickova@fpv.utc.sk

Vice-dean for education:

PhDr. Radoslava Turská, CSc.

E-mail: turska@fpv.utc.sk

**Vice-dean for science, research and foreign relations Socrates
faculty coordinator**

PhDr. Anna Hlavňová, CSc.

E-mail: hlavnova@fpv.utc.sk

Vice-dean for development

Prof. Ing. Ivo Čáp, CSc.

E-mail: icap@nic.utc.sk

General information

The history of the Faculty of Science is relatively short - the Faculty was established in August 1998 with an objective to complete the former mostly technically oriented education with courses in humanities. Although the first departments of the newly created Faculty were departments of mathematics, other departments were gradually established and currently there is a wide range of subjects that can be studied in bachelor's or master's programs and one subject also in a postgraduate program.

Although there are several universities in Slovakia offering full degree programs in English Language and Literature and/or concentrating on training teachers there is a permanent shortage of qualified teachers of English. To improve the situation the management of the Faculty decided to design new five-year degree programs concentrating on training teachers of English and another subject, as for example, mathematics/information science/music/religious studies. Curricula and courses were thoroughly redesigned to meet new requirements and incorporate the experience of the rest of the world. The courses allow for the training of either primary school or secondary school teachers. The courses offered by the Faculty are diverse.



Bachelor's degree programs: Mediamatics

Master's degree programs: Applied mathematics

Teacher Training (English in combination with physics/music/information science/mathematics/religious science)

Postgraduate degree program: Applied mathematics

Apart from this diversity the Faculty promotes a relaxed and friendly atmosphere that facilitates learning and experience.

The faculty is located in the very heart of the town. It is a place where undergraduate education is a lively, flourishing enterprise which is given the highest priority by the Faculty community. The courses are designed to meet the needs of schools in the 21st century. Relaxed and friendly atmosphere makes the Faculty an ideal place to study. The faculty staff help students realize educational and social needs and develop skills that are at present in great demand.

Departments of the Faculty

The faculty consists of the following departments:

- The department of mathematical analysis and applied mathematics,
- The department of algebra, geometry and didactics of mathematics,
- The department of mathematics,
- The department of physical sciences,
- The department of pedagogy and psychology,
- The department of humanities and social sciences
- The department of English language and literature,
- The department of foreign languages.

From the beginning of its existence the Faculty has endeavored to create an integrated partnership model with very strong theory and practical links. It is generally accepted that mathematics and, particularly, applied mathematics is an expanding area. Knowledge of the latest ideas, techniques and computational approaches is essential for today's mathematicians, be they involved in industry, commerce or research.

The courses offered by the all three departments of mathematics provide detailed knowledge and skills in certain key areas of modern mathematics including data analysis, numerical analysis, mathemati-

cal statistics, partial differential equations, linear algebra, analytical geometry, computer geometry, didactics of mathematics, etc. Appropriate attention is paid to statistics with the objective to train graduates to develop and apply statistical techniques, probability, mathematical statistics, linear models and computer-oriented statistical methods. Students are expected to achieve a basic knowledge of statistics and research methods. There are also courses covering most areas of computer science, for example, computer architecture, data base and information systems, logic and computation, theory of computation, parallel algorithms, etc.

Whenever possible, theory that is presented is matched with an appropriate real-world application, to enable the learner to appreciate the scope of the new ideas being encountered.

The aim of the courses designed to train teachers is to develop knowledgeable, enthusiastic and forward-looking mathematics teachers, who are confident in their ability to learn and grow professionally.

The Department of Humanities and Social Sciences together with **the Department of Pedagogy and Psychology** offer courses in philosophy, general and development psychology, history of culture and arts, theory of communication, political sciences, sociology, school management, etc. Within courses in philosophy the students are required to gain and display thorough knowledge of the history and problems of philosophy and considerable analytical skills. In the area of political sciences the curriculum combines theoretical and functional courses in a broad range of topics.

The courses in education strongly emphasize an interdisciplinary approach to professional training in education – linguistic and psychological perspectives are especially represented.

In courses devoted to *mediamatics* the students are trained to apply the theories and methods of social science to problems in interpersonal and mass communications, visual communication and cultural analysis and media management and regulation.

The music section aims to provide a congenial and friendly environment in which both staff and students share jointly in the study of music, both practical and theoretical. Each student is encouraged to develop his or her particular interests and abilities to the utmost. Music can be taken as a single course (performing on the musical instrument) or in conjunction with English. Teaching is by means of lectures, small-group seminars, and individual supervision.

The graduate programs of **the section of religious studies** draw widely on religious traditions, philosophy of religion, religious ethics.

English has become the uncontested number one foreign language in popularity and prestige in Slovakia although historically the country belonged to the German and Hungarian cultural area and German used to be the most widely taught and spoken foreign language. Later, due to political situation, Russian was a compulsory foreign language in all types of primary and secondary schools and also in institutions of higher learning. Towards the end of the 20th century study of English reinvigorated and its popularity has only increased in recent years.

When the Faculty decided to launch programs focusing on training teachers of English it was necessary to set up **the Department of English Language and Literature** alongside with the existing Department of Foreign Languages, which has been an integral part of the University since its very beginning, i. e. for 50 years. **The Department of Foreign Languages** provides courses in languages for specific purposes for students of all the faculties. Students can choose from the following languages: English, German, Russian, Spanish, French or Italian. The newly set up Department of English Language and Literature offers students who want to be teachers a flexible five-year program that combines broad coverage of both English and American literature and linguistics, which are well balanced. The MA programs for teachers of English (+ other subject), cover practical language instruction (analytical reading, writing, grammar, phonetics), linguistics (theoretical grammar, language history, lexicology, semantics, pragmatics), literature (both English and American) and cultural studies (British and American).

The aim of linguistics is to establish a thorough grounding in the study of language, and to develop the student's own ability to weigh up issues and analyze problems. The students explore the role of language as a means of communication in society, the production and transmission of speech, the basic workings of the sound system, the grammatical rules and the negation of meaning in language, and how languages change and compare with one another.

All courses are taught in English and thus students continue to develop their English skills through their university years.

Teachers from the two departments work both on questions of applied linguistics and language teaching methodology. They also have worked on questions of language and literature with applications in the language teaching process. Although up to now, research has been of secondary importance some significant work has been done on corpus linguistics and lexicography and translations.

These results have started to prove the potential of the Faculty specialists of foreign languages in the eyes of the University academic community which has traditionally regarded foreign philologists as mere language teachers.

The Department of English Language and Literature currently offers in-service training for practicing teachers from Slovak bilingual secondary schools who are to teach special subjects, e.g. history, geography, mathematics, etc. in English.

The Faculty has signed several bilateral agreements to recognize the grades awarded by other institutions enabling both students and staff to move between universities (e.g. within the framework of Socrates program).

Computing services

Computing facilities are provided at all sites in an open access computer laboratory to support development of student-centred learning and teaching. The faculty workplaces are fully networked and connected to the Internet.

Significant activities of the Faculty staff

From a wide range of diverse activities carried out by the faculty teachers and research workers the following projects are worth mentioning:

Katarína Labudová – Pavol Labuda

LOCAL SOCIETY INITIATIVE POLYLOGOS

E-mail: labudova@fpv.utc.sk; pavolbartolomej@pobox.sk

*Three things are extremely hard: steel,
a diamond and to know one's self.*

(Benjamin Franklin)



Description and objectives of the initiative

Polylogos group was established in 2001 as a local social network of academics with the aim to explain fundamental categories and subjects of individual disciplines as a platform of effective communication and tolerance. The dialogue and explanation of these categories is considered to be an inevitable condition for transfer of knowledge in the range of individual academic disciplines in Slovakia. To accomplish these objectives, the group regularly delivers workshops; lectures and seminars and on-line conferences, organizes meetings with invited specialists of particular scientific areas (science, formal science, philosophy, theology).

Anna Tománková

LEONARDO DA VINCI II Project: Deutsch im Maschinenbau (DEUMA) CZ/01/B/F/LA – 134057

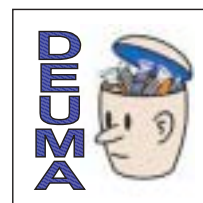

E-mail: tomankova@fpv.utc.sk

Description of the project

The project *Deutsch im Maschinenbau (DEUMA)* was approved by the European Commission in 2001 within the framework of LEONARDO DA VINCI II. Program. Its objective is to design a multimedia textbook of German for specific purposes. Participants in the project are from eleven different organizations from five countries. Five of the participants are from European member countries.

The DEUMA textbook is processed by means of multimedia software which was designed at the University of Tübingen that is also a partner of the project. The software is called *Telos Language Partner* and consists of preprogrammed multimedia patterns.

The textbook will cover nine topics focusing on mechanical engineering in a wider professional context so that the book can

be used in a wider spectrum of technically oriented schools. The textbook will be in two languages: in a target and mother language (German - Czech; German - French; German - Slovak). The final version will be provided in two versions: as CD and on the web.

The main domains agreed upon by experts after endless and numerous discussions are as follows:

- *Mathematics;*
- *Physics, mechanics,*
- *Materials,*
- *Connecting elements,*
- *Parts of machines – bearings,*
- *Parts of machines – gearboxes,*
- *Parts of machines – pistons and cylinders,*
- *Tools, apparatus, instruments,*
- *Interpretation of technical drawings.*

Each domain is further divided into a number of modules in which the main topic is presented in detail. Let us take the domain of Mathematics as an example:

- Module 1 - Sets of numbers.
- Module 2 - Calculation with natural numbers.
- Module 3 - Equations.
- Module 4 - Basic geometric vocabulary: point, straight line, half-line, line segment.
- Module 5 - Triangles, quadrangles, circles.
- Module 6 - Geometric bodies, cube, right parallelepiped, prism.
- Module 7 - Cone, tapered cone, cylinder, pyramid, sphere.

Each module contains:

- Introductory text with a video,

- Listening/reading comprehension exercises,
- Exercises to fix vocabulary,
- Grammatical exercises, etc.

Objectives of the project

- To provide a multimedia textbook of professional German;
- To combine classical foreign language teaching and learning with new technologies; thus promoting individual learning
- To support tele-tutoring as the next step in the above process,
- To widen, deepen and foster linguistic competences of Czech, French and Slovak learners using the above textbook thus improving their flexibility and better position in the European labor market.

Jozef Kúdelčík

THE MECHANISM OF NEGATIVE CORONA DISCHARGE IN ELECTRONEGATIVE GASSES

E-mail: kudelcik@fpv.utc.sk

Description and objective of the project

Electronegative gases as SF₆ and mixture N₂+SF₆, are widely used in many industrial devices, such as circuit breakers or gases insulating systems. The transmission from negative corona discharge to breakdown in these systems is unwelcome and elimination of this process depends on the understanding of the mechanism of

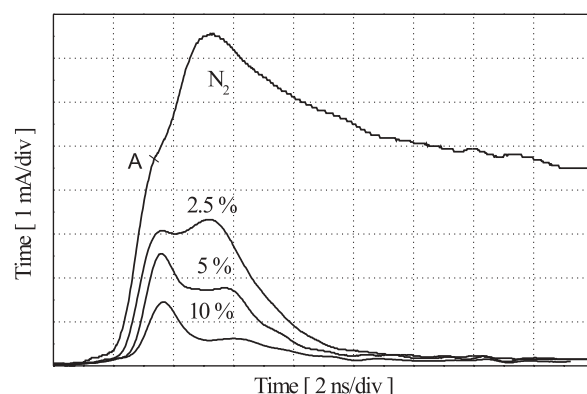

Fig. 1. Current pulse waveforms taken for various SF₆ admixtures at a gap voltage value 5 250 V and pressure 50 kPa (distance point-to-plane 12 mm a radius of the point 0.1 mm)

the initial stage of discharge. The initial stage of negative corona discharge is in the regime of Trichel pulses. Trichel mechanism presents wide and evident formation of cathode region at high pressure by streamer mechanism.

According to the streamer-based theory the stepped pulse leading edge, current pulses in N₂ and its mixture with low contents of SF₆ (Fig. 1), forms as follows: The initial current rises to the step (denoted by A) is due to a Townsend ionization mechanism fed by cathode secondary process (γ_p - emission). After decay the current rises due to the rapidly shrinking cathode fall region, the current begins to rise again because of the development of cathode-direct streamer-like ionization wave. The pulse maximum is attained just as the streamer reaches the cathode. Next quick current fall in mixture N₂ + SF₆ is due to negative space charge.

The above result interpreted in terms of streamer-based hypothesis suggests that the effect of adding >10% SF₆ to N₂ was primarily to quench the positive streamer ionization processes, while the effect of the Townsend multiavalanche ionization process was much less pronounced. One may therefore speculate that the strong streamer quenching in N₂ - SF₆ mixture has a very efficient corona stabilization effect. The effect of field emission on cathode graphite coating is important at pressure > 40 kPa.

Dalibor Blažek

THERMODYNAMIC STUDIES OF LOW DIMENSIONAL ISING MAGNETS

E-mail: blazek@fpv.utc.sk

We cooperate with the Department of Experimental Physics, Faculty of Science, University of P.J.Šafárik in Košice on studies of dipolar magnets. Our investigations have been focused on the $\text{KEr}(\text{MoO}_4)_2$ compound as an example of rare earth dimolybdates which represent dipolar magnets with a layered crystal structure. Previous thermodynamic studies of $\text{KEr}(\text{MoO}_4)_2$ in zero magnetic field B_0 have revealed that below the temperature of 2.5 K the model converges to the 2 dimensional Ising model with effective spin of $1/2$. A phase transition into the antiferromagnetic ordered state has been observed at Neel temperature of 0.955 ± 0.005 K. The analysis of specific heat data measured in the paramagnetic region in applied magnetic field parallel to an easy axis revealed deviations from the theoretical models. The discrepancies might be ascribed to the predominantly dipolar nature of magnetic correlations. On top of it, the heat capacity depends on the shape of the sample. In the figure there are developments of the heat capacity for four different samples, calculated at the temperature of 2.5 K. The shapes of samples are represented by their demagnetising factors N .

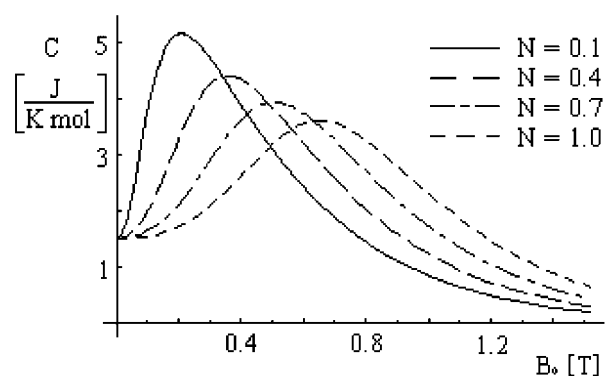

This research was supported by the Slovak Ministry of Education Grant No. 1/7473/20.

Anna Hlavňová – Vladimír Hlavňa

IS LANGUAGE THE FINAL BARRIER IN A SHRINKING WORLD?

Project UK/00/B/F/LA/129-019

Trans Europe Emergency Services Language Training Project



E-mail: hlavnova@fpv.utc.sk, vladimir_hlavna@kkvmz.utc.sk

Project objective

Recent international search and rescue operations have presented major difficulties in dialogue, information collation and technical understanding. This has caused operational difficulties and has emphasized the need for closer cooperation between potential countries.

How do emergency services improve cross-border support to emergency incidents/national disasters and ultimately assist in the

overall mobility of fire and rescue expertise? One way is by the development of language training within the emergency services.

Under the Leonardo da Vinci vocational training policy, Essex County Fire and Rescue Service, UK, together with six partner organizations, have been developing an innovative language training project known as Leonardo Emergency 112.



Description of the project:

This transnational training project aims to add value to international emergency service procedures, offering a more cost effective, efficient and professional response to the protection of life and property.

Emergency 112 aims to provide a basic building block for raising the awareness of, and the need for language/cultural interpretation of fire and paramedic terminologies.

It provides a multilingual training package of approximately 2,000 terms which will be available in CD-ROM, hard copy and on the web. The database is organized into a number of domains:

- Fire fighting,
- Medical rescue,
- Forest fires,
- Flashover,
- Special rescue,
- Hazmat.

The database is designed with a color-coded domain and sub-domain system for speedy reference. In addition to the basic terminology shown in the partner languages, training benefits will be enhanced by the addition of graphics to represent a term alongside an audio attachment.

Emergency 112 is capable of being developed much further with wider specialist terminologies, interpretation into additional languages and provision of interactive access. In reality, the project has almost infinite boundaries.

Miroslava Růžicková

SIGNIFICANT RESULTS OF RESEARCH IN THE FIELD OF MATHEMATICS

E-mail: ruzickova@fpv.utc.sk

In the beginning of our presentation we mentioned that the first departments of the Faculty of Science founded five years ago were two departments of mathematics. The original staff, who had worked at other faculties of the University, were gradually joined either by fresh graduates from various Slovak universities or by experienced and enthusiastic colleagues from other centers of mathematical research and education. At present the Faculty has three departments of mathematics and covers a wide range of mathematical disciplines thus representing a great potential of research workers. At the Faculty there are good conditions for the building of good research teams. The center of scientific activity is basic research whose results have been presented in numerous interna-

tional conferences and published in recognized professional journals.

Scientific and research activities in the departments of mathematics are diverse. The research in the field of *functional differential equations and their applications* follows the path marked by a reputable research school established by prof. RNDr. Pavol Marušiak, DrSc. The asymptotic and oscillatory properties of solutions of logistic differential equations with delay argument, neutral equations and systems, and singular differential systems are investigated. Oscillatory properties of functional integro-differential equations and their applications in mathematical models are also

studied. One of numerous important results of this research is the monograph written by P. Marušiak and R. Olach: *Functional differential equations*. At present, this research is supported by two grant projects.



Research in the field of *applied mathematics* deals with investigation of properties of logic models using the veracity coefficients. The methods of nonstandard analysis are used to join the process of logic. Functional and harmonic analysis is applied in works dealing with mathematical acoustics and also with special functions and orthogonal polynomials. Some researchers deal with numerical mathematics, especially with solution of partial differential equations using the mesh-less methods, and with their practical applications in the problems of vibrations of mechanical systems and in quantum physics.

Projects based on and supporting scientific and research activities of the staff:

- VEGA 1/5189/98 Functional spaces and their applications for solving nonlinear problems for partial differential equations (doc. RNDr. Ondrej Kováčik, CSc.)
- VEGA 1/5254/98 Oscillatory theory of ordinary and functional differential equations (prof. RNDr. Pavol Marušiak, DrSc.)
- VEGA 1/8055/01 Functional differential equations and their applications (doc. RNDr. Rudolf Olach, CSc.)
- VEGA 1/0026/03 Qualitative properties of functional differential and difference equations (prof. RNDr. Josef Diblík, DrSc.)
- International VTS project No. 22(025)/2000 Qualitative properties of solutions of functional differential equations and their applications. (doc. RNDr. Miroslava Růžicková, CSc.)
- International grant project SAV - CNR Integration in vector spaces equipped with additional structures (2001 - 2003) (doc. RNDr. Ján Haluška, CSc.).



INSTITUTE OF INFORMATION AND COMMUNICATION TECHNOLOGIES

INSTITUTE OF INFORMATION AND COMMUNICATION TECHNOLOGIES

Ústav informačných a komunikačných technológií
Moyzesova 20, 010 26 Žilina, Slovak Republic

E-mail: skruvt@uvt.utc.sk
Phone: +421-41-7245704
Fax: +421-41-5626961

Director: Ing. Jozef Mužík

The roots of keeping computers and information technologies at the University of Žilina go back to 1967, whilst the Computer Centre was established as an independent part of the Department of Mathematics and Descriptive Geometry at the Faculty of Mechanical and Electrical Engineering. In 1982, the Computer Centre was transformed into the Institute of Computer Technology. In that time the institute serviced great mainframes where all computational needs of the university were solved and the first steps toward the university network had been done as well. The institute gradually extended its services as new technologies were emerging. In the year 2003 this all led to the new transformation and renaming of the institute into the Institute of Information and Communication Technologies. At present the institute provides support for all activities tied up with the information and communication technologies at the University of Žilina. Many services, the list of which follows, are provided:

- help desk for students and university staff;
- control center and maintenance of smart cards;
- design, installation and maintenance of the University's networks;
- maintenance of the computers and their HW and SW equipment,
- support of servers, system and application software for the Integrated University Information System;



- consultancy to staff and students of exploitation of information and communication technologies in particular problems;
- negotiations of competitive software deals for the University;
- maintenance and expansion of the University's converged communication subsystem, (a combining of computer and telecom networks);
- representation of the University at the Slovak Academic Network association (SANET) and at many other meetings as requested;
- support of the University's Management Information System;
- advises and help regarding computer-related multimedia issues to staff and students;
- maintenance of computer labs for open access and booked classes;
- support for e-learning
- keeping documentation on the major software programs in use at the University.

The Institute of Information and Communication Technologies consists of the following teams:

- The Management Team
- The Communication Technologies Team
- The Computer Service Team
- The Application Software Team
- The Multimedia Technology Team

ACADEMIC METROPOLITAN NETWORKS AND SANET II

1. Introduction

The origins of the recent campus computer network of the University of Žilina stem from February 1991, when the Institute of Computing Technology (ICT) became the member of the EARN and EUNET organisations. The first functional network connection was accomplished by means of PC and modem (MNP 5, 2400 bps) and in June 1991 by connection of the mainframe computer EC1045 to the Regional computing centre at the Czech Technical University (CVUT) in Prague. This led to establishment of the EARN node in Žilina.

ICT participated in the founding of the Slovak Academic Network organisation (SANET), which was established in April 1991. After the end of the operation of the EC1045 mainframe and retreat of the over ecstatic hype from the easy accessibility of the stand-alone PCs and terminal connections, ICT was chosen by the top management of the University in March 1992 to design and construct the University backbone network (backbone UTC-Net, University of Transport and Communications Network). UTC-Net was conceived on the base of a multi-layer model, where the base layer forms the backbone. LANs of the Faculties form a higher level and the top layer forms the connection to SANET.

At the beginning, due to the lack of finance the circular topology was chosen. As the routers PCs 286/16 MHz or PCs 386SX/33 MHz were used, equipped with KA9Q software and 19,2 kbps modems Gandalf LDS 720, used for short distance connections. In the new NF University building structured cabling was laid. Router and DEC server interconnected the backbone and digital telephone exchange Alcatel 5200. This enabled the use of the "data over voice" service for telephones with RS 232 interface. UTC-Net started its round 'o'clock operation on 10. 7. 1992.

UTC-Net developed since that time in many of its quantitative and qualitative attributes. They are the increase of speed and quality of individual connecting elements, change to star topology and mainly the change of ways and quality of connection with permanent fixed lines, radio lines and optical cables.

2. SANET II

The start of SANET was not an easy task, mostly because of economic reasons. A lot of effort was necessary to ascertain approval of the finance for the operation of SANET, for the membership fees for international networking organisations and for the international connection to the Internet networking structures from the ever-thin budget of the Ministry of Education. The Gov-

ernment of the Slovak Republic by its decree No. 383/2001 decided to design and put into operation SANET II, the high-speed communication infrastructure with connection to the European communication network, connecting all the university centres in Slovakia. The Slovak government approved Decree no. 522/2001 on Policy of transfer to Information Society and joining of Slovakia to the of the eEurope+ initiative.

After reaching the end of the I. Stage of the SANET II project in the first half of 2002, the following results have been reached:

1. Universities in Slovakia are connected to trans-European information highways.
2. The elementary goal of the network – to enable access to quicker Internet to as large number students as possible – is accomplished.
3. One part of the Slovak academic network has reached the same transfer speed as the speed of the networks in the most developed European countries – 1Gbit/s.

The elementary objective of the project – to help with the development of the Information Society in the Slovak Republic, by means of providing availability of the high speed networking for scientific, educational and research purposes, development of new applications, e.g. those enabling an easier access to information resources in EU and Slovakia, development of new services, as teleconferencing, distance education, medical consultation centres, etc.

Connection to the Trans-European network, developed by the Fifth and considered of utmost importance by the recent Sixth Framework Programmes will be made possible by the development of the high-speed network infrastructure in Slovakia. This will provide possibility of better co-operation with scientific and academic institutions in EU and easier inclusion of Slovak institutions in the international research and development projects. This should provide for:

1. Access to numerous information resources (databases) developed and maintained by Slovak institutions, or international information resources kept in Slovakia.
2. Provision of multimedia communication channel in the framework of educational services provided by Universities and as support for national and international scientific conferences for information interchanges.
3. Distance education (e-learning), which in future will provide the possibility to increase throughput of Slovak education in all of its various forms and levels.
4. Development of medical consultation centres, for provision of qualified telemedical services.
5. Provision of access to supercomputing capacities in the specialised European supercomputer centres.

Among participating institutions in the SANET II project we can find universities, institutes of Slovak Academy of Sciences, research institutions, university hospitals and clinics. The access to SANET network is possible in 16 towns altogether in 21 nodes. The ultimate goal of the SANET II project is an optical backbone, connecting all university, educational and cultural centres, as: Bratislava - Trnava - Piešťany - Trenčín - Púchov - Žilina - Martin - Liptovský Mikuláš - Poprad - Tatranská Lomnica - Prešov - Bardejov - Michalovce - Košice - Rožňava - Rimavská Sobota - Lučenec - Banská Bystrica - Zvolen - Prievidza - Nové Zámky - Galanta - Dunajská Streda - Bratislava, by hired optical cables. The status of the SANET II network in January 2003 is shown in Fig. 1.



Fig. 1 SANET II January 2003

SANET as an institution is member of all important European networking organisations and since its conception participates in all projects of academic network infrastructure development in the EU framework, such as COSINE, ESSAT, TELESERV, EURO-PANET, INSIDE. Thanks to participation in these projects and co financing from the European sources it was in the past possible to finance the development of the SANET network. The project supposes to connect the high-speed infrastructure to trans-European network through the participation in the European consortium GEANT (Gigabit European Advanced Network Technology). The central node of the SANET network (at CVT STU in Bratislava) serves as a node of the GEANT network in Slovakia as well. The agreement concerning connection with speed of 155 Mbps, with possible increase to 2.5 Gbps has been signed already. To ascertain this international connectivity, 50 % of the costs are covered by grant from EU. Further connection to the global network will be made through transatlantic operator EBONE. Further development should lead to interconnection with academic networks of the neighbouring countries (Czech Republic, Austria, Hungary).

The big advantage of the SANET II project is the possibility of establishment of metropolitan networks in the University centres. The centres concerned are located in Bratislava, Košice, B. Bystrica, Nitra, Žilina and Trnava. It is supposed that the transfer speed in

the metropolitan networks should be 100 Mbps or 1 Gbps. It is suggested that such infrastructure can be developed with proprietary or hired cables with the Ethernet protocol use.

3. Academic metropolitan network of the University of Žilina

At the same time as the project SANET II started, the development of the *Academic metropolitan network of the University of Žilina* started as well. The development consisted of preparation and realisation of the university metropolitan network, transformation of the networks of faculties, based on thin and thick Ethernet technologies and definition of the base parameters of the university metropolitan network. New infrastructure should connect all-important localities of the University. The technology used should be financially accessible, reliable and should enable future upgrades of the network with minimum costs.

The first stage of the realisation of the metropolitan network started in the beginning of the 2002 and was concluded in November 2002, at the same time as connection to SANET II. The Metropolitan network connects Veľký Diel campus - Faculty of Management Science and Informatics - administration building - Faculty of Civil Engineering - Student dormitories - University library. In the Veľký Diel campus area the following buildings are reconnected to the network - the buildings NR, NS, new acquired building, technical building, Unimo H. During the first stage 7 710 m of optical cable was laid.

The Metropolitan network is based on the switched Ethernet technology. A physical layer is built with optical threads (single mode, multimode) as structured metallic cabling of Category 5. Switched Ethernet provides possibilities for required quality of service and granted bandwidth of 10/100Mbps for the end user. The backbone of the academic MAN in Žilina has 1Gb bandwidth. Such a breadth of the band makes possible e.g. transfer of 4 GB of data in 40 s, parallel transfer of about 100 videoconferences in real time, video on demand (in the cable TV quality), voice over IP - transfer of voice in a very high quality. The sites which are still connected by coaxial cable (shared 10Mb Ethernet) cannot use services or applications provided by the switched Ethernet technology to a full extent. The fulfilment of the 2nd stage of the metropolitan area network is scheduled for the year 2003. The project of connecting the Faculty of Special Engineering with optical cable and the Faculty Science with radio line to the Faculty of Civil Engineering node has been sent to SANET for approval.

The base parameters for the *Academic metropolitan network of the University of Žilina* were defined as follows: guarantee of bandwidth of 10/100Mb for the end user, Quality of Services (QoS) support, virtual networks support, multicasting support, central management of network, clustering, IP telephony, Video on Demand.

4. Broadband networks

4.1 QoS (Quality of Service)

Classical data networks, dedicated solely to the transfer of data, do not guarantee quality of the transport services. They developed independently of the voice services networks. Mostly the liberal environment, as compared with traditional telecommunication networks, usually monopolised by telecom operators, has fuelled rapid development of data networks. Continuous development and increase of available bandwidth and storage capacity in certain moment led to possibility of voice transfers over data networks. These technologies are either of the VoIP type (Voice over Internet Protocol), which “pack” digitised voice to IP protocol packets, or the VoFR type (Voice over Frame Relay), which “pack” digitised voice into the Frame Relay protocol frames. This possibility led to convergence of both types of networks. Recent data networks use the principle of switched packets. Transfers of voice and video however are very sensitive to transfer delays and jitter. For these reasons guarantee of transfer services became necessary. The term QoS (Quality of Service) came into use. Support of QoS is based on the idea that transfers speeds, intensity of errors and further transfer parameters are measurable entities and therefore there is possibility of their improvement and provision of guarantee on certain level. QoS especially concerns continuous (streamed) transfers of video and multimedia content in the broadband networks. In the networks it is very difficult to guarantee the use of common protocols based on the “best effort” principle. One possibility is to assign different priority levels to different types of data. These priorities enable packets with higher priority to pass through the inner nodes more quickly, than packets with lower priority. IP protocols do support use of priorities; its implementation in practice is rather rare. New ways of implementation are being searched. One of the possibilities is the use of MPLS protocol (MultiProtocol Label Switching), which speeds up the network traffic and gives possibility of its easier management. MPLS sets a specific path for a given sequence of packets, identifies the level set for each packet, which saves time necessary for the router to evaluate the address of the following node, to which the packet should be sent. The “Multiprotocol” designation in MPLS shows, that it can work with IP protocol, s ATM (Asynchronous Transport Mode) protocol and Frame Relay networking protocol. From the OSI reference model (RM OSI) point of view, protocol MPLS makes possible that more packets are routed in the second layer (switching) than in the third layer (routing). Another protocol which makes the switching in the third level of the RM OSI possible is the COPS (Common Open Policy Service) protocol. Transfer delay and jitter can be dealt also by other means. It is possible to use several reservation methods, which use the principle of putting aside (reserving) part of the transfer capacity available for transfers with specific requirements and demands. Reserved transfer capacity can be used according to the principle of circuit’s interconnection. With this kind of interconnection used also by ATM transfer technology, it is possible to guarantee required transfer parameters. Reservation of certain transfer capacity in the TCP/IP networks can be ascertained by the use of RTP protocols

(Real Time Protocol) and/or RSVP protocol (Resource Reservation Protocol).

4.2 Virtual networks

Data networks are used concurrently by a number of independent users. Their use of addresses from the common address space makes communication among them possible. At the same time the current throughput of the network is dependent of the concurrent requirements of the users. Some tasks and users require certain degree of intimacy while using the network and its services. It is possible with use of certain technologies to create “insulated” networks within network, thus giving the user the feeling of proprietary “private” network. This is a mere illusion, so these networks are designated as Virtual Private Networks (VPN). A part of the VPN illusion is the independent own address space and the possibility of direct communication only among the participants of the concrete VPN. Communication with other “external” network users is possible only through the defined (and guarded) gate. “Logical” illusion may be enhanced in practical application by “physical” illusion, granting its user certain bandwidths. The biggest advantage of VPN is the possibility to maintain security of data transfers. The mechanism which serve as illusion of private network providers may serve at the same times as information encoders, the information is then transferred in its encrypted form and decoded at the user side.

Utilisation of the data networks requires significant financial and human resources and know-how. As a good “saving” practice outsourcing may be used. It may take a form of one time activity, such as development of the data network, or continuous activity, such as operation of the network, user support etc. At the same time this can concern private data network, owned and used by a single user.

4.3 IP telephony

IP protocol transfer attributes are in no way ideal for the voice transmission. Despite this undisputable fact, this protocol is widely used for telephony over the data networks. It is mostly due to the fact that data networks are widely available and therefore this effort for their multiple use for voice services as well. Solutions based on the IP protocol are used not only for interconnection of the exchange nodes of the operators in the network backbones, but also for connection to the current end users. To ascertain coexistence between data transfers based on the IP protocol and “classical” telephony, their interoperability is necessary. This interoperability as well as telephony in the IP data networks is codified by standard H.323. This standard has been developed by the International Telecommunication Union (ITU) for multimedia communication in the LAN environment, based on packet transfer, regardless of the guarantee of Quality of Services (QoS). It tackles as compulsory part audio (voice) communication, in the mandatory part video and data communication. Standard defined for the

main elements supporting transfer of information in the packet networks:

- Terminals: These are the terminal nodes, enabling bidirectional communication in real time. Typical examples are “data phones”, but classical PC with the software packages such as Microsoft NetMeeting may be used.
- Gateways: These serve for interconnection with classical telephone networks, based on the principle of circuit connection. Standard H.323 concerns packet networks.
- Gatekeepers: This is an equivalent of telephone exchange for H.323 compatible networks.
- Multipoint Control Units (MCU): Ascertain communication in case of conference-like transfers (among multiple participants).

All terminals compatible with H.323 have to support point-to-point communication. Bidirectional communication between two terminals may be managed by administrator of the respective zone or by MCU. Information content of the conference may be sent to individual terminals using the point-to-point mode. Multicast type of transfers may be transformed to series of unicast type of transfers and sent to individual terminals without specific support on the side of the network topology. MCU may possibly function in reverse – they may serve as receptors of more than one unicast transfers of point to point type and produce one stream of multicast data, used for transfer of information from one source to multiple concurrent users.

4.4 Video on demand (VoD)

Competition for the user and (at the same time) customer is rapidly developing in the video service domain. TV stations broadcast their programmes 24 hours a day through the Internet, where their broadcasting servers are positioned as nodes in the backbone. Many of these servers function on the Microsoft platform (making reception with the help of the “free” MS Media Player possible). It is nowadays possible to choose from different transfer speeds available, which gives possibility to adjust the reception

to the actual bandwidth available. The video is shown in styled browser window the user side. In reality the player is embedded into the WWW page, showing downloaded or streamed video. There are still some problems with the players embedded into styled screen, e.g. with visibility of control buttons, with synchronous playing of sound track and with some codecs.

5. Conclusion

The practical implementation of the SANET II project provided possibilities for establishment and further development of academic metropolitan networks based on optical technologies. Technical limits of optical connections lie in the fantasy domain. As far as the network services are concerned, the throughput available makes services as software distribution by network, access to music files, videoconferencing, video on demand (VoD), Internet telephony (VoIP), and such possible. Concrete content on demand, enabling personalisation of the services may be provided. The term content networking begins with realisation of SANET II based on the optical connection to have its concrete contours.

References:

- [1] Horváth P., Druga P.: *Information and communication infrastructure – important priority of the process of the move towards information society*. In: Proceedings of the conference Infosem 2002, (in Slovak), Piešťany, 2002
- [2] Horváth, P.: *Project SANET II – realisation of high-speed academic data network for science, research and education*. In: Proceedings of the international conference – Information and communication technologies for all, (in Slovak), Bratislava, 2002
- [3] Zelem, J.: *Computer network of VŠDS – UTC-Net*, In.: Proceedings of the national conference Informatika '93, Information technologies and computing technology in educational institutions, pp. 197-200, (in Slovak), Bratislava, ÚIP ŠMT, 1993.

CETRA



**CENTRE FOR TRANSPORTATION
RESEARCH UNIVERSITY
OF ŽILINA**

CENTRE OF EXCELLENCE CETRA - TWO YEARS OF EXISTENCE

Assoc. Prof. Ing. Peter Fabián, CSc.
Prof. Ing. Ladislav Skýva, DrSc., academician
Lubica Kalúsová

CETRA - Ústav dopravy, Žilinská univerzita v Žiline
Moyzesova 20, 010 26 Žilina
Phone: +421-41-5620075
Fax: +421-41-5620075
E-mail: cetra@utc.sk
WWW: www.utc.sk/cetra

1. Introduction

CETRA - Institute of Transport at the University of Žilina has been selected for support by the European Commission within the "Support for Research Infrastructures in the New Associated States" project within the EU 5th Framework Programme. The support is oriented and used towards organisation of international conferences, workshops, participation in the international conferences and workshops, publication of research results and long-term working stages of scientific staff at CETRA.

At present, after two years of project duration, it is possible to evaluate and reflect on the project activities and achieved results. Establishment and activities of CETRA gain importance in connection with the opening of the EU 6th Framework programme and its first calls for project proposals in the defined priority areas. Apart from the main task, co-ordination of approved CeTra and INTRANSNET projects, CETRA is devoting most of its activities towards successful inclusion of the University of Žilina in the preparation of new 6th FP project proposals in the transportation domain and inclusion in the emerging pan-European Networks of Excellence.

2. EU approach to definition and establishment of centres of excellence in Europe

European Union (EU) started to use the term Centres of Excellence (CE) in the period of 1999-2000. EU published the



document *Towards...* [5] in January 2000. In this document the establishment of unified European Research Area is envisaged. As a supplement to this report (*Towards...* [5]) many other supporting materials, concerning the concept of CE have been published.

The approach visible in the EU documents may be characterised by narrowing of the CE concept to research and technology development. The kernel document *Action...* [3] proposes following simple CE definition: "Centre of excellence is a structure, doing research and technology development on the state-of-the-art level and from the viewpoint of measurable scientific output (including scientific education) and technological innovations". Important parts of this concept are:

- "Critical mass" of highly qualified scientific and developers staff, transparent structure (mostly based on existing research structures),
- Ability to integrate similar research domains and associate complementary skills,
- Ability to maintain high-level exchange of qualified human resources,
- Dynamic task of connected innovation system (added value of knowledge),
- High level of international recognition and connection to research and industrial environment,
- Appropriate level of financial stability and conditions of existence (good base for investment in human resources and establishment of partner relations),
- Financial resources not limited by time factor or public decision.

The impact in the EU working paper (*Centres...* [6]) is put on the ability of the competent Centre to gain qualified international human resources. In this document also the fact that there does not exist any precise definition of the CE and that the CE designation is often misused. According to this document, for the real CE following factors are the most important:

- a) CE is capable of providing work positions for highly qualified research staff (it is capable of attracting “high calibre” researchers),
- b) These researchers are capable of developing innovative ideas and technologies (which may lead to breakthroughs in respective scientific disciplines).

In the document, there are some characteristics given, based on the research conducted in the US. They compare successful research institution (which nevertheless does not qualify for the CE designation) with the “true” Centre of excellence – see Table 1.

Characteristics of the Centre of Excellence (CE) Table 1

Some basic characteristics of successful organisations	
made significant groundbreaking discoveries (and could be described as CE)	carrying out worthwhile research (but not constituting CE)
Multidisciplinarity or diversity of disciplines	Excessive diversity or hyper-diversity of disciplines
Easy communication between groups and individuals	Strong differentiation between departments
Strong leadership	Hierarchical authority
	Bureaucratic co-ordination

Source: Centres... [6] with reference to survey conducted by prof. Hollingsworth

In addition to what is summarised in Table 1, the paper concludes that “adequate financial resources, good organisation and infrastructure, are all necessary but they are not sufficient. Centres of Excellence depend ultimately on their ability to attract excellent researchers.” As far as the innovative performance is concerned, importance of researcher mobility is also emphasised by the OECD.

Based on earlier propositions (e.g. in [4]), the European Union assigns importance to the following issues in its new framework programme:

- centres of excellence should be explored,
- CE should become renowned (impact of CE should be maximised),
- capable centres should be integrated into networks (of excellence),
- integrated projects should also help the birth of CEs.

Benchmarking problems for CE designation are explored in great detail in the article of Borsi and Kedro [2]. The resulting proposal for criteria is summarised in Table 2.

The project supporting research infrastructures in the new associated states is part of the 5th FP. Within the framework of this project European Commission has chosen and supports 34 Institutions, designated as Centres of Excellence. Duration of the project is three years. The centres are located in 11 of 12 new associated states. 9 of the centres is located in Poland, 6 in Hungary, 4 in Romania, 3 in Bulgaria, Czech republic, 2 on Cyprus, in Slovakia, Slovenia and Estonia and 1 in Lithuania. They cover 8 broader scientific disciplines – biology (11 Centres), information society technologies (6), physics (5), mathematics (3), technology (3), social sciences and economics (2), medicine (2) and environment (1). From 34 supported CE, 23 are located at the Institutes of Academy of Science, 9 at Universities and 2 at other institutions. More about project CeTra and the Centre of Excellence located at the University of Zilina may be found in the article *Skyva-Fabián* [7], information on the activities of the project and their execution may be found in [1]. Topical information on the whole project supporting the Centres may be found at <http://www.cordis.lu/inco2/src/coe.htm>.

3. Overview of the achieved results

The activities of the CeTra project, coordinated by the Institute of Transportation – CETRA, Centre of Excellence recognized and supported by the EC, are described in detail in the Periodic reports, sent to Brussels by the end of each respective half-year planning period [1]. We would like to use this opportunity to

Proposed benchmarks of being excellent and being a centre

Table 2

Typology of innovative R&D	Being excellent	Being a centre
<ul style="list-style-type: none"> - single disciplinary versus interdisciplinary R&D - R&D based on major infrastructure (e.g. CERN) - university-industry collaboration - industrial applied R&D (e.g. GE lab) 	<ul style="list-style-type: none"> - appears in bibliometry - patents filed - doctorate and post-doc positions offered and occupied - number of research personnel and visiting scientists - number and volume of commercial contracts - number of spin-offs - international co-operation - networking 	<ul style="list-style-type: none"> - critical mass of researchers (either in a central location or virtually linked) - international impact - relationship with the legal entity that sells the innovation - social recognition
Qualitative and quantitative benchmarks for knowledge generation / utilisation / diffusion		

Source: Borsi-Kedro [2]

present in graphical form, how the Centre manages to fulfil the above mentioned requirements on “Centrality” and “Excellence”. The graphs show the results of the first two years of the three year long project (December 2001-May 2002). The respective half-year periods are designated by their number 1-4.

Fig. 1 shows number of scientific staff from EU and associated countries accepted for long-term working stays at CETRA and financed by the project grant. It is clear that CETRA is quite successful (so far) in this kind of activity, which is given the utmost priority by EC in the CE projects. In the last two periods stays with duration much longer than minimum 1 month (required by EC) appear. In total there were 33 persons with total length of 52 person-months participating in this kind of activity.

The graph in picture 2 depicts numbers of incoming and outgoing persons, participating in short term visits, conferences and workshops financed under the project grant. Some trips were covered only partially by the project, thus requiring co-financing by the involved institutions or individuals.

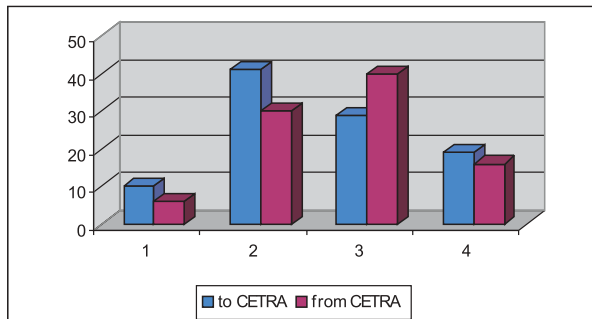

Fig. 2. Short-term stages of scientific staff supported by CeTra

Altogether there were 99 incoming persons and 92 outgoing persons. The countries of origin and destinations are shown in picture 3.

The project grant created the opportunity to support high number of international conferences and workshops held at CETRA. Altogether there were 13 conferences and 14 workshops fully or

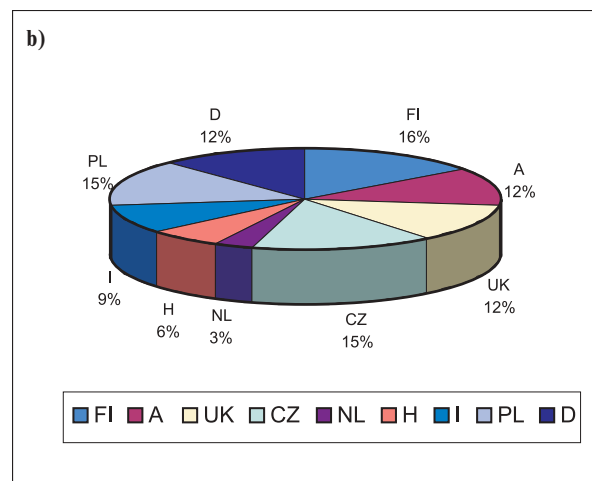
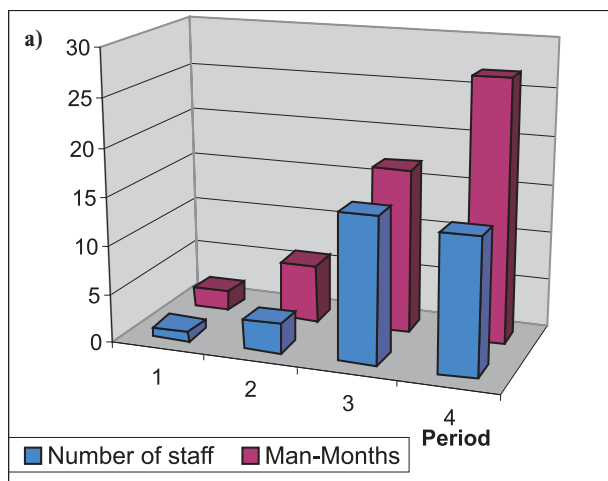

Fig. 1. Long-term stages of scientific staff supported by CeTra, according to (a) their numbers and (b) percentage according to country of origin

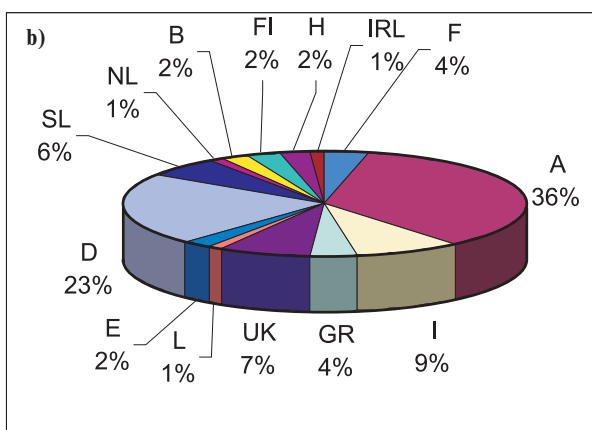
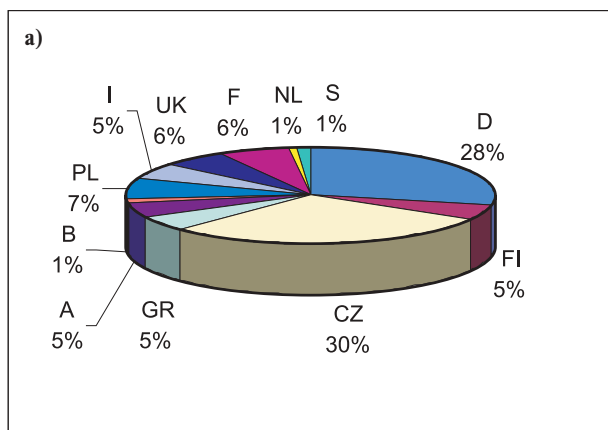

Fig. 3. Short-term stages of scientific staff according to (a) country of origin - incoming visitors and (b) destination - outgoing visitors

partially supported by the project. Their distribution in the past periods is shown in picture 4.

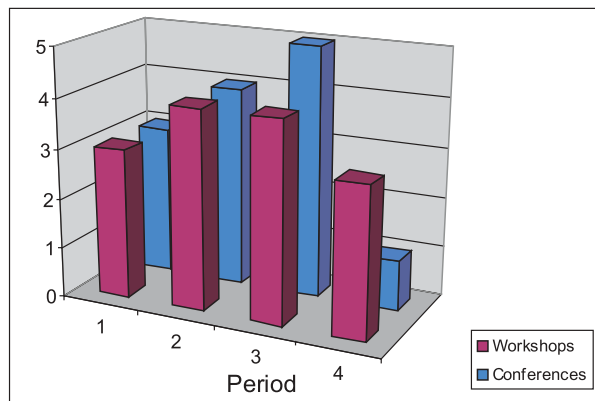

Fig. 4. Organisation of conferences and workshops supported by CeTra

In the *first period* there were held following conferences and workshops: Žel 2001, Elektro 2001, Quality 2001 - International Road Conference - Asphalt Pavements, Control and Simulation of Transportation Processes on a Microscopic Level, RTD on Development of Electric Traction Vehicles and Transport Production.

In the *second period* there were: Transcom 2001, Modernization of Railway Tracks, 4th National Productivity Forum, Transport in Urban Agglomerations, Radio Based Operation on Branch Lines, Safety Analysis of Interlocking and Signalling Systems, CEEC - Central European Educational Cycle for Designers and Technologists, 1st European Workshop on Material Flows Simulation.

In the *third period* there were: Žel 2002 - "Railways on the Edge of the 3rd Millennium", New Developments in the Field of Modelling, Control and Optimisation of Transport Processes, QUALITY - 2002: "The Technology of Roads Maintenance", Concrete and Concrete Structures, CEEC-Central European Educational Cycle for Designers and Technologists - 2nd part, Control and Simulation of Transportation Processes, Control and Management of Transportation Processes on Microscopic Level, Topical problems in Business and Road Transport.

In the *fourth period* there were: Modernisation of Railway Tracks, Aviation Training Safety Enhancement, Summer School of Fatigue of Materials, Traffic Effects on Environment.

Financial support for the project follows the path envisaged for all new 6th FP projects. Contracting institution (in our case the University of Žilina) receives an advance payment of approximately 40% of the commitment. The payment is made when the contract is signed by both parties (contractor and EC). The amount paid by the Commission as advance is to be considered as a "pre-payment" to allow a particular project to commence, but the advance amount shall need to be justified by costs submitted over the duration of the project. Given that 15 % of commitment must

be kept for the final payment, the costs claimed will be reimbursed only up to these 15 %. Only after the approval of final report, the final payment will be done, including eventually these 15 % of the initial commitment (even an amendment cannot change the initial amount of the grant). This scheme is certainly not very advantageous and only thanks to understanding and support from the University and financial support by the University and Ministry of Education, which helped to survive the Centre quite difficult moments and continue the project activities.

Apart from administration of the CeTra and another 5th FP project INTRANSNET (in the framework of the GROWTH programme) CETRA focuses its activities on preparation of involvement of University of Žilina in the 6th FP. This includes dissemination of the information on the 6th FP and preparation of the project proposals. With the CETRA character as Centre of Excellence the most prospective looks its incorporation in emerging Networks of Excellence.

4. 6th FP and networks of excellence

The most important parts of the 6th FP are integration of European research, restructuring of the European Research Area (ERA) and strengthening of its foundations.

The elementary principles of the new framework programme are oriented towards research in the chosen priority domains, co-ordination and simplification of bureaucratic processes and reaching of the structuring effect by co-ordination with other European, national and regional initiatives. Apart from traditional tools, known from the 5th FP initiatives, the main focus should be set towards implementation of the new tools as Integrated Projects and Networks of Excellence.

Networks of Excellence

The objective of the Network of excellence is to enhance gained level of excellence in concrete area of research by integration of critical mass of resources and expertise necessary for creation of top level European consortia of institutions. This consortium must form distinctive force in the respective research domain on the world level. Expertise should be used in the framework of network's joint programme of activities, which should be used for integration of the research capacity of the network participants and continuing improvement of the research activities.

Network of Excellence is a tool which should serve to strengthen the excellence by removing the existing scattering and separation of the European research. Main focus should be on development of permanent influence on the way, how the research in the respective research area is conducted. The fact that the investments are going into the consortia of excellent research workers should grant that the networks will improve conditions for further development of priority scientific disciplines, even if it is not their main mission. These networks should not behave as closed entities, increasing their own excellence within their partnership. The duty of each network is to disseminate excellence behind the

boundaries of the consortia with the use of dissemination activities and education of new scientific workers.

The network is conceived around the joint programme of activities - JPA. This programme contains activities which partners of the network should do together. Some of these activities are:

- Integration activities,
- Programme of jointly carried research,
- Excellence dissemination activities.

First calls for project proposals were published on 17. 12. 2002 and first proposals should be put forward in March or April 2003 (according with the concrete Calls). All information on 6th FP project proposals is available on www.cordis.lu/fp6, or on the National Contact Points web pages in the associated countries.

5. 6th FP and transportation research

As it has been shown, the priority research domains of the 6th FP do not explicitly mention transportation (apart from Aeronautics and Space research) and do not concentrate it to one priority theme. Similarly, as in the previous 5th FP, this research is scattered in different priority domains, for which the increase in efficiency, quality and safety of transport is inevitable. So we can find transportation oriented research themes in Information Society Technologies (IST), Sustainable Development, and Support for Research Infrastructures domains

The transportation sector is represented mostly by the following calls:

- New technologies and concepts for all kinds of surface transport (road, rail, water),
- Innovative technologies for design and production of products,
- Balance of various modes of transport and their integration,
- Safety enhancement in road-, rail- and water transport, congestion prevention.

Recently, in the whole Europe there is a lot of activity going on. Everybody who would like to step into the mainstream of the European research is trying to form consortia, capable of producing an answer to the recent first calls for project proposals within the 6th FP. CETRA is also wishing to continue with its role as research integrator and promoter and actively participate in preparation of Expression of Interest (EoI), which preceded the Calls and is recently involved in dissemination of the 6th FP ideas and preparation of participation in several Integrated projects and

Networks of Excellence. We hope that with the help of the University and co-workers in Departments and Faculties oriented towards transportation research our activities will lead to successful involvement in the 6th FP projects.

6. Conclusion

The Centre's of Excellence concept, as perceived by the European Commission, has been used for establishment and support of such research and development structures, as CETRA - Institute for Transport at University of Žilina. Natural expansion of this idea leads to the establishment of European Networks of Excellence, which are supposed to cover respective priority research domains, as defined by the European Commission. From the territorial point of view, they are supposed to include as broad as possible base of the top research establishments in the European Union and associated countries. Although the transport as such is not included in the priority domains, all kinds of transport are included in calls for project proposals in the defined domains. Start of the participation in the mainstream of the European research and becoming a partner in projects of the 6th FP is not simple. However, this goal should become an important part in the Development plans of all research institutions and in the work plan of all persons, responsible for research and development.

7. References

- [1] SKYVA, L., FABIÁN, P., KALÚSOVÁ, L.: *Periodic reports of the CeTra Project*, CETRA, 2001, 2002, 2003
- [2] BORSI, B., KEDRO, M.: *The „Centre of Excellence” Concept: Examples from the Literature and Practice of Some Countries*, internal materials of EU RECORD project, 2002
- [3] European Commission: Action for „centres of excellence” with a European dimension, Brussels, 2000
- [4] European Commission: Strategy for a real research policy in Europe, Brussels, January 2000.
- [5] European Commission: Towards a European Research Area. Communication from the Commission to the Council, the European Parliament, the Economic and Social Committee and the Committee of the Regions, Brussels, 2000
- [6] European Commission: Centres of Excellence in the EU - Attracting international talent. Policy Advice, Brussels, 2001
- [7] SKYVA, L., FABIÁN, P.: *CETRA a ERA*, in Proceedings of the conference INFOTRANS 2002, Univerzita Pardubice, 2002

COMMUNICATIONS – Scientific Letters of the University of Žilina Writer's Guidelines

1. Submissions for publication must be unpublished and not be a multiple submission.
2. Manuscripts written in English language must include abstract also written in English. The submission should not exceed 7 pages (format A4, Times Roman size 12). The abstract should not exceed 10 lines.
3. Submissions should be sent: **by e-mail** (as attachment in system Microsoft WORD) to one of the following addresses: *holesa@nic.utc.sk* or *vrablova@nic.utc.sk* or *polednak@fsi.utc.sk* **with a hard copy** (to be assessed by the editorial board) **or on a 3.5" diskette** with a hard copy to the following address: Zilinska univerzita, OVaV, Moyzesova 20, SK-10 26 Zilina, Slovakia.
4. Abbreviations, which are not common, must be used in full when mentioned for the first time.
5. Figures, graphs and diagrams, if not processed by Microsoft WORD, must be sent in electronic form (as GIF, JPG, TIFF, BMP files) or drawn in contrast on white paper, one copy enclosed. Photographs for publication must be either contrastive or on a slide.
6. References are to be marked either in the text or as footnotes numbered respectively. Numbers must be in square brackets. The list of references should follow the paper (according to **ISO 690**).
7. The author's exact mailing address, **full names, e-mail address, telephone or fax number, and the address of the organisation where the author works** and contact information must be enclosed.
8. The editorial board will assess the submission in its following session. In the case that the article is accepted for future volumes, the board submits the manuscript to the editors for review and language correction. After reviewing and incorporating the editor's remarks, the final draft (before printing) will be sent to authors for final review and adjustment.
9. The deadlines for submissions are as follows: September 30, December 31, March 31 and June 30.

POKYNY PRE AUTOROV PRÍSPEVKOV DO ČASOPISU KOMUNIKÁCIE – vedecké listy Žilinskej univerzity

1. Redakcia prijíma iba príspevky doteraz nepublikované alebo inde nezasielané na uverejnenie.
2. Rukopis musí byť v jazyku anglickom. Príspevok by nemal prekročiť 7 strán (formát A4, písmo Times Roman 12 bodové). K článku dodá autor **resumé** v rozsahu maximálne 10 riadkov (v anglickom jazyku).
3. Príspevok prosíme poslať: **e-mailom**, ako prílohu spracovanú vo Word-e, na adresu: *holesa@nic.utc.sk* alebo *polednak@fsi.utc.sk* príp. *vrablova@nic.utc.sk* (alebo doručiť na diskete 3,5") a **jeden výtláčok** článku na adresu Žilinská univerzita, OVaV, Moyzesova 20, 010 26 Žilina.
4. Skratky, ktoré nie sú bežné, je nutné pri ich prvom použití rozpísať v plnom znení.
5. Obrázky, grafy a schémy, pokiaľ nie sú spracované v Microsoft WORD, je potrebné doručiť buď v digitálnej forme (ako GIF, JPG, TIFF, BMP súbory), prípadne nakresliť kontrastne na bielom papieri a predložiť v jednom exemplári. Pri požiadavke na uverejnenie fotografie priložiť ako podklad kontrastnú fotografiu alebo diapozitív.
6. Odvolania na literatúru sa označujú v texte alebo v poznámkach pod čiarou príslušným poradovým číslom v hranatej zátvorke. **Zoznam použitej literatúry** je uvedený za príspevkom. Citovanie literatúry musí byť **podľa záväznej STN 01 0197 (ISO 690)** „Bibliografické odkazy“.
7. K rukopisu treba pripojiť **plné meno a priezvisko autora a adresu inštitúcie v ktorej pracuje, e-mail adresu** a číslo telefónu alebo faxu.
8. Príspevok posúdi redakčná rada na svojom najbližšom zasadnutí a v prípade jeho zaradenia do niektorého z budúcich čísel podrobí rukopis recenzii a jazykovej korektúre. Pred tlačou bude poslaný autorovi na definitívnu kontrolu.
9. Termíny na dodanie príspevkov do čísel v roku sú: 30. september, 31. december, 31. marec a 30. jún.



VEDECKÉ LISTY ŽILINSKEJ UNIVERZITY
SCIENTIFIC LETTERS OF THE UNIVERSITY OF ŽILINA
5. ROČNÍK – VOLUME 5

Šéfredaktor – Editor-in-chief:
Prof. Ing. Pavel Poledňák, PhD.

Redakčná rada – Editorial board:
Prof. Ing. Ján Bujňák, CSc. – SK
Prof. Ing. Karol Blunár, DrSc. – SK
Prof. Ing. Otakar Bokúvka, CSc. – SK
Prof. RNDr. Peter Bury, CSc. – SK
Prof. RNDr. Jan Černý, DrSc. – CZ
Prof. Ing. Ján Corej, CSc. – SK
Prof. Eduard I. Danilenko, DrSc. – UKR
Prof. Ing. Branislav Dobrucký, CSc. – SK
Prof. Dr. Stephen Dodds – UK
Dr. Robert E. Caves – UK
Dr.hab Inž. Stefania Grzeszczyk, prof. PO – PL
PhDr. Anna Hlavňová, CSc. – SK
Prof. Ing. Vladimír Hlavňa, PhD. – SK
Prof. RNDr. Jaroslav Janáček, CSc. – SK
Dr. Ing. Helmut König, Dr.h.c. – CH
Prof. Ing. Gianni Nicoletto – I
Prof. Ing. Ludovít Parilák, CSc. – SK
Ing. Miroslav Pfliegel, CSc. – SK
Prof. Ing. Pavel Poledňák, PhD. – SK
Prof. Bruno Salgues – F
Prof. Andreas Steimel – D
Prof. Ing. Miroslav Steiner, DrSc. – CZ
Prof. Ing. Pavel Surovec, CSc. – SK
Prof. Ing. Hynek Šertler, DrSc. – CZ
Prof. Josu Takala – SU
Prof. Dr. Zygmund Szlachta – PL
Prof. Ing. Hermann Knoflacher – A

Adresa redakcie:
Address of the editorial office:

Žilinská univerzita
Oddelenie pre vedu a výskum
Office for Science and Research
Moyzesova 20, Slovakia
SK 010 26 Žilina
Tel.: +421/41/5620 392
Fax: +421/41/7247 702

E-mail: *polednak@fsi.utc.sk*, *holesa@nic.utc.sk*

Každý článok bol oponovaný dvoma oponentmi.
Each paper was reviewed by two reviewers.

Časopis je excerptovaný v Compendexe
Journal is excerpted in Compendex

Vydáva Žilinská univerzita
v EDIS – vydavateľstve ŽU
J. M. Hurbana 15, 010 26 Žilina
pod registračným číslom 1989/98
ISSN 1335-4205

It is published by the University of Žilina in
EDIS - Publishing Institution of Žilina University
Registered No: 1989/98
ISSN 1335-4205

Objednávky na predplatné prijíma redakcia
Vychádza štvrtročne
Ročné predplatné na rok 2002 je 500,- Sk

Order forms should be returned to the editorial office
Published quarterly
The subscription rate for year 2002 is 500 SKK.

Jednotlivé čísla časopisu sú uverejnené tiež na:
Single issues of the journal can be found on:
<http://www.utc.sk/komunikacie>