

5

Péter Fodor – Ádám Marquetant  
POSÚDENIE STRATÉGIÍ TARIFIKÁCIE  
PRUŽNÉHO PREVÁDZKOVÉHO ZATAŽENIA  
NA KOMUNIKAČNOM SPOJI  
EVALUATION OF PRICING STRATEGIES OF ELASTIC  
TRAFFIC ON A SINGLE COMMUNICATION LINK

---

9

Ivan Feňo - Eduard Jadroň - Pavol Špánik  
RIADIACE OBVODY PRE SÉRIOVÝ, ČIASTOČNE  
REZONANČNÝ MENIČ  
CONTROL CIRCUITRY FOR A PARTIAL SERIES  
RESONANT CONVERTER

---

14

Rastislav Kuliha  
PRINCÍPY ZNIŽOVANIA RIZIKA  
RISK REDUCTION PRINCIPLES

---

19

Csaba Balázs - Judit Pfeifer  
ŠTRUKTURÁLNE A MORFOLOGICKÉ VYŠETROVANIE  
STARNUTIA HYDRÁTU KYSLIČNÍKA WOLFRÁMOVÉHO  
PRI IZBOVEJ TEPLOTE V ALKALICKOM VODNOM  
PROSTREDÍ  
STRUCTURAL AND MORPHOLOGICAL OBSERVATIONS  
ON TUNGSTEN OXIDE HYDRATES AGED AT ROOM  
TEMPERATURE IN ALKALI CONTAINING  
AQUEOUS ENVIRONMENT

---

26

Jana Václavková – Eudovít Kupča  
APLIKÁCIA SKÚŠKY TYPU SMALL PUNCH TEST PRI  
HODNOTENÍ DEGRADÁCIE VLASTNOSTÍ MATERIÁLOV  
TLAKOVEJ NÁDOBY REAKTORA  
A SMALL PUNCH TEST METHOD APPLICATION FOR  
THE EVALUATION OF REACTOR PRESSURE VESSEL  
MATERIAL PROPERTIES DEGRADATION

---

31

Octavian Pop – Tamás Máhr  
Tímea Dreilinger – Róbert Szabó  
ARCHITEKTÚRA DOJEDNÁVANIA ŠÍRKY PÁSMA  
V SIEŤACH DIFFSERV  
BANDWIDTH BROKER ARCHITECTURE  
FOR DIFFSERV NETWORKS

---

36

Luboš Buzna  
NÁVRH ŠTRUKTÚRY DISTRIBUČNÉHO SYSTÉMU  
S POUŽITÍM ÚDAJOV O SKUTOČNOM OSÍDLENÍ  
ZÁSOBOVANEJ OBLASTI  
THE DISTRIBUTION SYSTEM DESIGN PROBLEM  
APPLYING REAL SETTLEMENT DATA

---

41

Peter Koteš – Josef Vičan – Jiří Slavík  
VPLYV KORÓZIE VÝSTUŽE NA SPOHLIVOSŤ  
EXISTUJÚCICH BETÓNOVÝCH KONŠTRUKCIÍ  
INFLUENCE OF REINFORCEMENT CORROSION ON  
RELIABILITY OF EXISTING CONCRETE STRUCTURES

---

50

Róbert Tenzer  
GEPOTENCIÁLNY MODEL ZEME – APROXIMÁCIA  
TVARU ZEME, METÓDY TESTOVANIA  
GEPOTENCIÁLNYCH MODELOV  
GEOPOTENTIAL MODEL OF EARTH – APPROXIMATION  
OF EARTH SHAPE, GEOPOTENTIAL MODEL TESTING  
METHODS

---

59

Mária Franeková  
MATEMATICKÝ APARÁT PRE VÝPOČET PRAVDEPO-  
DOBNOSTI CHYBY DEKODÉROV BLOKOVÝCH KÓDOV  
MATHEMATICAL APPARATUS FOR ERROR  
PROBABILITY DETERMINATION OF BLOCK CODE  
DECODERS

---

65

Marian Josko - Marcin Jarmuzek  
HODNOTENIE ADHEZÍVNYCH SPOJENÍ MEDZI  
POVLAKOM A SUBSTRÁTOM S POUŽITÍM  
ULTRAZVUKOVEJ SPEKTROSKOPIE  
EVALUATION OF ADHESIVE JOINTS BETWEEN COATING  
AND SUBSTRATE USING ULTRASONIC SPECTROSCOPY

---

70

Dana Sitányiová  
VPLYV DEZINTEGRAČNÝCH METÓD NA VÝSLEDKY  
HUSTOMERNEJ SKÚŠKY  
THE INFLUENCE OF DISINTEGRATION METHODS ON  
TEST RESULTS FOR ASSESSMENT OF THE SOIL  
PARTICLE SIZE DISTRIBUTION

---

80

Janka Šestáková – Milan Mikšik  
EKOTECHNOLÓGIE PRI OPRÁVÁCH KONŠTRUKCIE  
PODVALOVÉHO PODLOŽIA  
ECOTECHNOLOGIES FOR THE RECONSTRUCTIONS  
OF RAILWAY SUBGRADE CONSTRUCTION

---



***Vážení čitatel,***

*Štvrtá medzinárodná vedecká konferencia TRANSCOM 2001 organizovaná taktiež ako aktivita v rámci projektu CETRA (Centre for Transportation Research, University of Žilina, Slovak Republic - Centre of Excellence supported by European Commission), sa uskutočnila v júni 2001 na Žilinskej univerzite v Žiline, Slovenská republika.*

*Základným zámerom konferencií TRANSCOM, organizovaných pravidelne každý druhý rok od roku 1995, je prezentácia vedeckých prác (z oblastí dopravy, spojov, strojárstva, elektrotechniky a stavebníctva) mladých výskumných pracovníkov, vrátane doktorandov do 35 rokov veku z univerzít, výskumných ústavov a praxe.*

*Viac ako 325 príspevkov (v anglickom alebo nemeckom jazyku) bolo reálne publikovaných v 7 zborníkoch konferencie TRANSCOM 2001 (zo zahraničia 174 príspevkov, Bulharsko, Česká republika, Fínsko, Juhoslávia, Nemecko, Maďarsko, Poľsko, Rumunsko, Rusko, Taliansko, Ukrajina, 50 príspevkov bolo z iných univerzít Slovenska a 104 príspevkov zo Žilinskej univerzity v Žiline).*

*Toto číslo Komunikácií, vážený čitateľ, je venované vybraným príspevkom (odporúčaných vedeckým výborom) zo 4. medzinárodnej vedeckej konferencie TRANSCOM 2001, Žilina, Slovenská republika.*

***Dear reader,***

*the 4-th International scientific conference TRANSCOM 2001, organised also as an activity in the framework of the CETRA project (Centre for Transportation Research, University of Žilina, Slovak Republic - Centre of Excellence supported by the European Commission), was held in the University of Žilina, Slovak Republic, in June 2001.*

*The main purpose of the conferences TRANSCOM organised regularly every two years since 1995, is a presentation of scientific works (from the fields of transportation, telecommunications, mechanical, electrical and civil engineering) of young research workers incl. PhD. students up to the age of 35 from universities, scientific institutions and industry.*

*More than 325 contributions were published in seven proceedings of conference TRANSCOM 2001 (174 contributions were from abroad, Bulgaria, Czech Republic, Yugoslavia, Germany, Hungary, Poland, Romania, Russia, Italy, Ukraine, 50 were from the universities of the Slovak Republic and 104 contributions were from the University of Žilina).*

*This volume of Communications is devoted to the selected contributions (recommended by scientific committee) of the 4-th International scientific conference TRANSCOM 2001, Žilina, Slovak Republic.*

*Otakar Bokůvka*

Péter Fodor – Ádám Marquetant \*

# POSÚDENIE STRATÉGIÍ TARIFIKÁCIE PRUŽNÉHO PREVÁDZKOVÉHO ZATAŽENIA NA KOMUNIKAČNOM SPOJI

## EVALUATION OF PRICING STRATEGIES OF ELASTIC TRAFFIC ON A SINGLE COMMUNICATION LINK

*Budúce siete s integrovanými službami, podporujúce viaceré triedy prevádzkového zataženia, budú vyžadovať zákaznické stratégie riadenia prístupu a zdieľania frekvenčného pásma, ktoré splnia rôzne požiadavky na zaručenú kvalitu služieb (QoS) alebo dátový tok a pružnosť služieb. Výsledky súčasného výskumu ukazujú, že je dôležité overiť riadenie prístupu volaní (CAC) pre pružné prevádzkové zataženie, nakoľko algoritmus CAC umožňuje napríklad zabrániť reláciám TCP pre nadmernú degradáciu priepustnosti [1], [2]. Aby bolo možné pre pružné volania určiť optimálny algoritmus CAC, overili sme na základe modelu spoja zavedeného v [2] pomocou Markovovej teórie rozhodovania rôzne stratégie tarifikovania. Ukážeme, že optimalizácia CAC maximalizuje nielen príjmy, ale tiež zvyšuje pravdepodobnosť blokovania prevádzky tokov s vysokou prioritou a QoS pružného prevádzkového zataženia, ak je tarifikačná funkcia použiteľná.*

*The future integrated service networks supporting multiple traffic classes will require customized admission control and bandwidth sharing strategies, which meet the diverse needs of QoS (Quality of Service)-assured (stream) and best-effort (elastic) services. Recent research results indicate that it is meaningful to exercise call admission control (CAC) even for elastic (best-effort) traffic, because CAC algorithms provide a means to prevent e.g. TCP sessions from excessive throughput degradations [1], [2]. Based on a model of a single link introduced in [2], we evaluate different pricing strategies assigned to elastic calls by determining an optimal CAC using Markov Decision theory. We will show that optimizing CAC not only maximizes average revenue, but also improves blocking probability of high priority stream traffic and QoS of elastic traffic as long as appropriate pricing functions are applicable.*

### 1. System Model

We formulate our system model following the approach described in [1] and [2].

**Traffic Model** We investigate a single link, to which two types of traffic classes offer load: *stream* and *elastic*. Stream traffic is supposed to represent a service with strict QoS guarantees (e.g. VoIP in IP or CBR in ATM), while elastic traffic models best effort-like services (e.g. TCP in IP, ABR in ATM). Stream calls are described by their arrival rate  $\lambda_1$ , departure rate  $\mu_1$  and peak rate  $B_1$ , and elastic calls by their call arrival rate  $\lambda_2$ , their ideal departure rate  $\mu_2$ , their peak rate  $B_2$  and minimum rate  $r_{min} * B_2$  ( $0 \leq r_{min} \leq 1$ ). Both types of calls arrive according to independent Poisson processes and the holding time for stream flows is exponentially distributed with mean  $\mu_1^{-1}$ . In case of elastic calls the number of bits to transfer is exponentially distributed with mean  $B_2 * \mu_2^{-1}$ . By ideal departure rate we mean that the actual *service ratio*  $r(t)$  of elastic calls in progress may fluctuate between  $r_{min}$  and 1, thus the service time increases accordingly. All elastic connections in progress on the link share the available bandwidth equally among

them [4]. A newly arriving call will be accepted if there is enough free capacity on the link by the compression of elastic flows (elastic flows can be compressed down to  $r_{min} * B_2$ ). If the available free capacity on the link is smaller than the minimum rate of the new call, then the flow will be rejected. When a flow departs elastic calls inflate their bandwidth consumption up to  $B_2$ .

**System Description** Let  $C$  denote the link capacity. The system under investigation (with the above assumptions regarding the arrival processes and holding times) is a Continuous Time Markov Chain (CTMC) whose state is uniquely characterized by  $(n_1(t), n_2(t))$  where  $n_1(t)$  is the number of stream calls and  $n_2(t)$  is the number of elastic calls on the link at time  $t$  ( $0 \leq n_1(t) \leq \lfloor C / B_1 \rfloor$ ,  $0 \leq n_2(t) \leq \lfloor (C - n_1(t)) / (r_{min} * B_2) \rfloor$ ). Let the state space  $S$ . The vector  $(n_1(t), n_2(t))$  uniquely specifies what service ratio  $r(t)$  of in-service elastic calls receive  $r(t) = \min[1; (C - n_1(t) * B_1) / (n_2(t) * B_2)]$ . In order to obtain the performance measure of this system we need to determine the CTMC's generator matrix  $Q$  and its steady state solution,  $\underline{p}$ . The non-zero transition rates of generator matrix are:

\* Péter Fodor, Ádám Marquetant

High Speed Networks Laboratory, Department of Telecommunications and Telematics, Budapest University of Technology and Economics, H-1117, Pázmány Péter sétány 1/D, Budapest, Hungary, Tel.: +36-1-463 2187 Fax: +36-1-463 3107  
e-mail: fodorp@ttt-atm.ttt.bme.hu, marquet@ttt-atm.ttt.bme.hu

$$q(n_1, n_2; n_1 + 1, n_2) = \lambda_1$$

$$q(n_1, n_2; n_1 - 1, n_2) = n_1 \cdot \mu_1$$

$$q(n_1, n_2; n_1, n_2 + 1) = \lambda_2$$

$$q(n_1, n_2; n_1, n_2 - 1) = n_2 \cdot r_2(n_1, n_2) \cdot \mu_2$$

according to call arrival or departure. The state probability vector

has to satisfy  $\sum_{j \in S} p_j = 1$ , and  $\underline{PQ} = \underline{0}$ . Let  $\underline{B}_i$  denote the blocking

probability vector of traffic class  $i$ .  $\underline{B}_i$  contains those states where a newly arriving call from traffic class  $i$  is blocked.

$$\underline{B}_1 = \{(n_1, n_2) \in S : (n_1 + 1, n_2) \notin S\} - \text{stream}$$

$$\underline{B}_2 = \{(n_1, n_2) \in S : (n_1, n_2 + 1) \notin S\} - \text{elastic}$$

Then the blocking probability of traffic class  $i$  is

$$P_i = \sum_{(n_1, n_2) \in \underline{B}_i} p_{(n_1, n_2)}. \quad (1)$$

To get the average holding time of elastic calls we need to know the mean number of elastic flows on the link from

$$E[n_2] = \sum_{(n_1, n_2) \in S} n_2 p_{(n_1, n_2)} \quad (2)$$

where  $n_2$  is the number of elastic calls in all state. From Little's formula the mean time an elastic call spends in the system is  $E[T_2] = E[n_2] / (\lambda_2 \cdot (1 - P_2))$  and the average service ratio of elastic flows is  $r_{avg} = 1 / (E[T_2] \cdot \mu_2)$ .

**Pricing Model** To represent that stream and elastic calls are of different value to the provider we also assume that both types of calls generate revenue that is a function of the occupied bandwidth. The link-wide instantaneous revenue accumulation rate  $\rho(t)$  is given by

$$\rho(t) = n_1(t) * B_1 + n_2(t) * B_2 * \varphi(B_2, r(t), r_{min}) \quad (3)$$

We assume that a unit stream bandwidth generates revenue with a unit rate, while a unit elastic bandwidth generates revenue with a rate proportional to  $\varphi$ .

**Optimal CAC Policy based on Markov Decision Theory** The simplest call admission policy (CAC) may be the one, which admits a new call whenever the link is capable to accommodate it (i.e. by compressing all elastic flows down to their minimum ratio  $r_{min}$ ). Note, that we will refer to this kind of CAC 'no Markov Decision' (*no\_MD*) in Section 4. We argue that there is a need to apply more sophisticated CAC policies with the following two reasons. First, the provider is seeking after to increase its income, therefore it is straightforward to price stream flows requiring strict QoS guarantees higher and prefer them whenever both stream and elastic flows aspire for admission. Second, users generating stream flows expect better service deservedly for their money.

We aim at finding a CAC policy that assigns to each system state a decision whether to admit or reject arriving stream and elastic calls so that the long-term revenue is maximized. To achieve our goals we apply Markov Decision theory [3], which algorithmically takes into account the revenue generation rate of different system states and yields the optimal solution in a finite number of steps.

## 2. Pricing Strategies

Formula (3) allows a multitude of pricing strategies to apply to elastic calls. We present two of them, which we think are relevant in the context of optimizing CAC to achieve maximum possible revenue for the provider and improve QoS and blocking probability of stream flows. First of all we introduce our underlying assumptions.

First, the price of a stream call's unit bandwidth should be higher than that of an elastic call to be able to satisfy strict QoS requirements by ensuring that only a fraction of users will claim to those services. Secondly, it is beneficial to price elastic calls requiring larger minimal service ratios  $r_{min}$  higher. (These calls have a larger percentage of their bandwidth guaranteed and are more like to stream calls.) Otherwise, subscriber may spare money by offering a wider band elastic call instead of an expensive stream call ( $B1 \approx r_{min} * B_2$ ). We have found two simple pricing strategies fulfilling the above requirements (see Fig. 1).

### 2.1. 'Linear' Pricing

The revenue generation factor of elastic traffic is directly proportional to the service ratio. (Represented as a line on Fig. 1, which would begin from the origin if we could decrease the service ratio down to zero) ( $\varphi_{lin}(t) = rev_{lin} * r(t) = k * r_{min} * r(t)$ ). This strategy fulfills both criteria mentioned above, provided constant  $k$  falls into range ( $0 < k \leq 1/r_{min}$ ). Note that different  $r_{min}$  values entail lines with different gradient on Fig. 1.

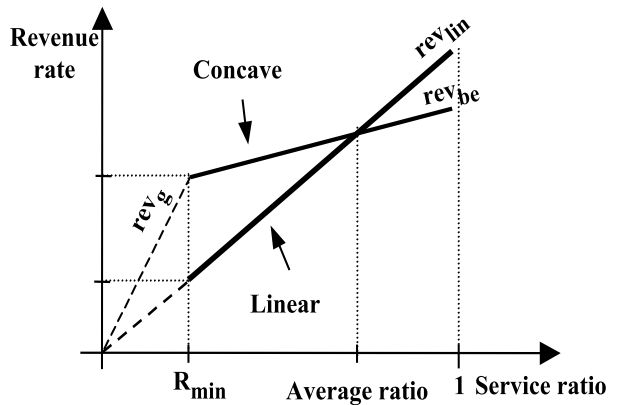

Fig. 1

## 2.2. 'Concave' Pricing

At the second solution this line is shifted up and its gradient is smaller than that of the other. In this case the revenue rate has two parts. One of them is a guaranteed rate, what the customer always has to pay. The best effort part has linear increment, which has to be paid when the service ratio is greater than the minimum service ratio.

( $\varphi_{con}(t) = rev_g * r_{min} + rev_{be} * (r(t) - r_{min})$ ), which meets the above mentioned requirements if  $0 \leq rev_{be} \leq rev_g \leq 1$ . So the curve must be concave, hence the name.

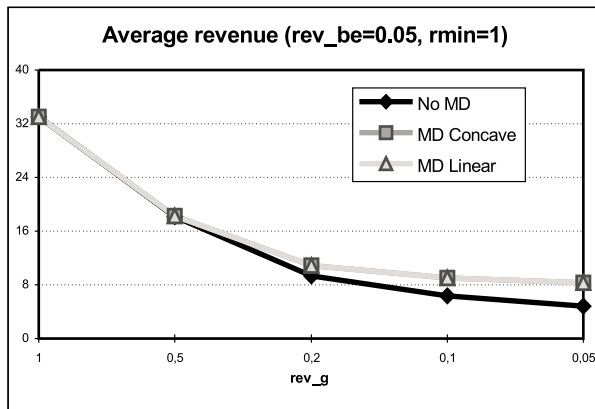

Fig. 2

## 3. Numerical Results

To evaluate the pricing strategies we investigated a single link of capacity  $C = 40$  Mbps. Stream calls with bandwidth demand  $B_1 = 8$  Mbps arrive with intensity  $\lambda_1 = 1 \text{ s}^{-1}$ , while elastic calls with bandwidth demand  $B_2 = 1$  Mbps (peak) arrive with intensity  $\lambda_2 = 8 \text{ s}^{-1}$ , where  $r_{min}$  decreases from 1.0 down to 0.2. The holding times of two traffic classes are assumed to be exponential with mean values  $1/\mu_1 = 1 \text{ s}$  and (ideally)  $1/\mu_2 = 4 \text{ s}$ . Aside from  $r_{min}$ , our moving parameters are  $rev_g$  (assuming values 0.05, 0.1, 0.2, 0.5, 1) and  $rev_{be}$  (assuming values 0.05, 0.2, 0.4). The offered traffic to the link is equal to its capacity in all our measurements, hereby we were modeling a good provisioned network (link). Our main measures of interest are long-term average revenue, stream and elastic class blocking probability and average elastic service ratio ( $r_{avg}$ ) and holding time. Fig. 2, Fig. 3, Fig. 4, Fig. 5 and Fig. 6 show these measures as the function of guaranteed revenue factor ( $rev_g$ ) for a fixed best-effort revenue factor ( $rev_{be}$ ) and minimal service ratio ( $r_{min}$ ) of elastic calls.

On Fig. 2, Fig. 3, Fig. 4, Fig. 5 and Fig. 6 we compare three kinds of CAC algorithms labeled 'no MD', 'MD concave' and 'MD linear'. 'no MD' stands for the simple CAC that does not take into account revenue generation rates of calls, but works on an is-enough-bandwidth basis (see Section 2.). The other two CAC's are outcome applying the Markov decision optimization in the same

environment (with the same elastic  $r_{min}$ ) as in case of the respective 'no MD' CAC, using respective pricing strategies as input to the optimization. To be able to compare the *linear* and *concave* pricing strategy we first apply the 'no MD' CAC and based on the resulting average elastic service ratio ( $r_{avg}$ ) we calculate the gradient of the linear strategy ( $rev_{lin}$ ) as the function of concave parameters as follows:  $rev_{lin} = (rev_g * r_{min} + (r_{avg} - r_{min}) * rev_{be}) / r_{avg}$  (see Fig. 1). Thus, under 'no MD' both strategies will produce the same average revenue (they 'offer' the same amount of revenue to the network).

Fig. 2 shows the average revenue of the link in function of guaranteed revenue factor ( $rev_g$ ) of elastic calls. Naturally, the greater is the  $rev_g$ , the greater is the long-term average revenue. This figure also reveals that Markov Decision is only capable of effective increase average revenue when elastic flows are much lower priced ( $rev_g$  is close to 0.05), however, at the price of much higher elastic blocking probabilities. Comparing two pricing policies in terms of guaranteed revenue rate of elastic calls there is no sufficient variance.

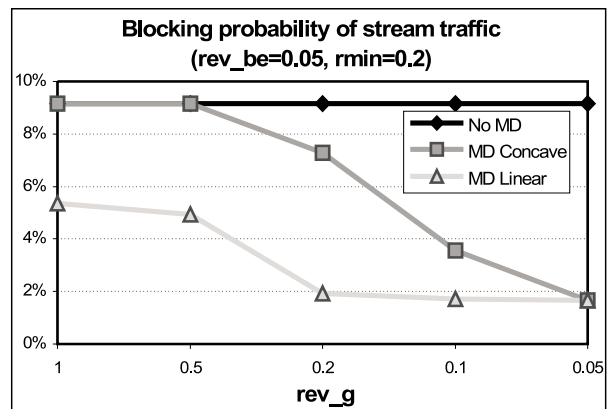

Fig. 3

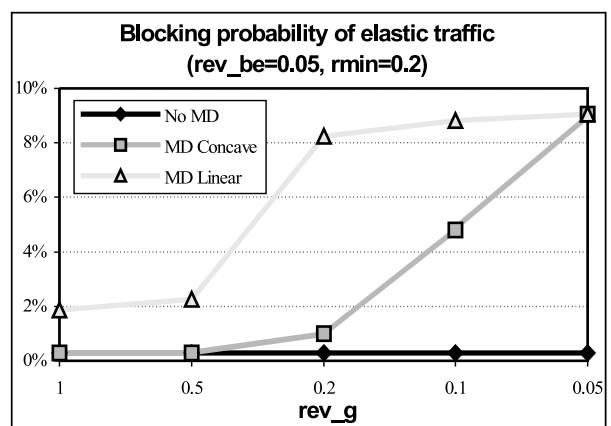

Fig. 4

Fig. 3 and Fig. 4 show interesting results. Even if there is no considerable average revenue increase with MD, the blocking probabilities are much more effected. Without MD, stream calls have

much higher blocking probability than elastic calls. MD, however, decreases the blocking probability of stream traffic, while that of elastic flows will be increased. We just mention that by applying MD elastic average service rate ( $r_{avg}$ ) has been increased providing better QoS to elastic flows (Fig. 5).

In linear pricing case the blocking probability of stream calls decreased more than when using the concave pricing policy. Analogously, blocking probability of elastic calls increased more by the linear policy. These results are caused by two phenomena. The MD algorithm is blocking elastic flows even if there was place for them on the link to admit newly arriving stream calls with higher probability. Elastic calls can expand more in the meantime therefore the average rate of service ratio shifts right. In linear pricing case this expansion generates the same per unit bandwidth revenue as if we admitted more elastic calls with smaller service ratio. However, in case of concave pricing, increase of average service ratio would result in lower per unit-bandwidth revenue, since the gradient of its revenue generation factor is smaller. So, the smaller is the service ratio of elastic flows priced concave, the greater is the long-term average revenue of the link. Therefore the algorithm considers the probability of arriving a new great-revenue stream call of less value, which causes greater blocking probability for stream traffic.

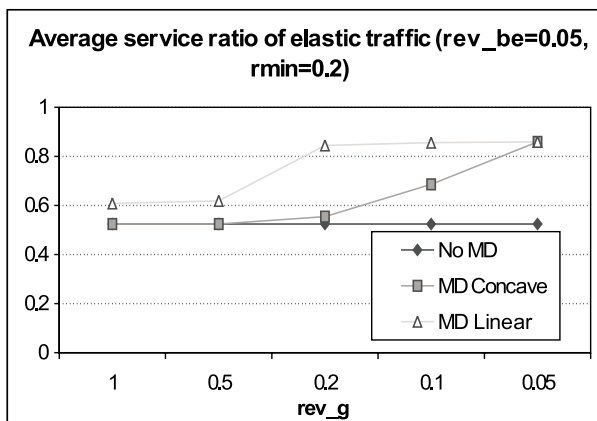

Fig. 5

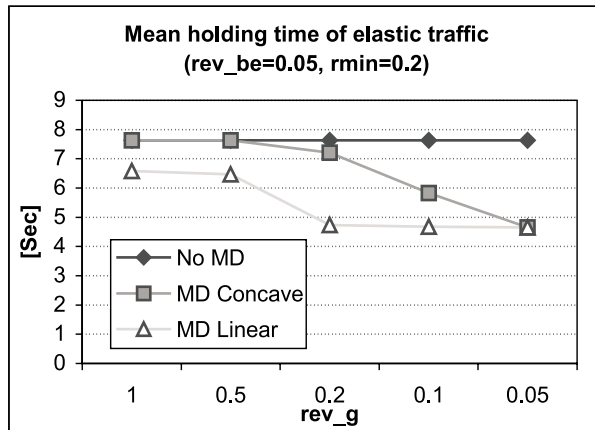

Fig. 6

Fig. 5 shows the average service ratio of elastic flows. In accordance with the above mentioned phenomena if the revenue factor of guaranteed part is much higher than that of the best effort part, in case of concave pricing strategy MD tries to keep the average service ratio of elastic calls near minimum service rate. In the linear pricing case this ratio increased much more since more elastic calls are blocked. If the guaranteed part is lowly priced then the effect of second phenomenon diminishes, therefore the concave curve approximates to linear. Fig. 6 shows the mean holding time of elastic calls, which is really for subscribers. It is inversely proportional to the average service rate, therefore in linear pricing case the mean time that an elastic call spends in the system is smaller than in concave pricing case.

#### 4. Conclusion

In this paper we studied pricing policies for elastic flows to be applied on a communication link accommodating stream and elastic calls. First, we showed a model that is able to describe the dynamics of the link and then presented elastic pricing policies which in combination with Markov Decision optimization can yield better blocking probability measures for high priority stream traffic and maximize revenue of network provider.

#### 5. References

- [1] Rudesindo Núñez Quejia, Hans van den Berg, Michel Mandjes: *Performance Evaluation of Strategies for Integration of Elastic and Stream Traffic*
- [2] G. Fodor, E. Nordstrom and S. Blaabjerg: *Revenue Optimization and Fairness Control of Priced Guaranteed and Best Effort Services on an ATM Transmission Link*, ICC'98, vol 3, pp. 1696-1705, Atlanta, GA, USA, 1998
- [3] Henk C. Tijms: *Stochastic Models - An Algorithmic Approach*, John Wiley & Sons, Chichester, 1984
- [4] Shigang Chen, Klara Nahrstedt: *An Approach to Pricing and Resource Sharing for Available Bit Rate (ABR) Services*, in Proceedings of Euro-Parallel and Distributed Systems Conference (Euro-PDS '98), Vienna, Austria, July 1998, pp.163-168

Ivan Feňo - Eduard Jadroň - Pavol Špánik \*

# RIADIACE OBVODY PRE SÉRIOVÝ, ČIASTOČNE REZONANČNÝ MENIČ

## CONTROL CIRCUITRY FOR A PARTIAL SERIES RESONANT CONVERTER

Príspevok predkladá riešenie riadiaceho obvodu pre nový vysokofrekvenčný DC-DC menič vhodný pre aplikácie vo výkonovom rozsahu niekoľko kilowatov. Zapojenie výkonovej časti meniča je založené na sériovom polomostovom rezonančnom meniči. Rezonančný jav sa vyskytuje len počas časti periódy činnosti meniča. Počas každej polperiódy meniča sa transformuje na sekundárnu časť diskretný energetický impulz. Tým je umožnené riadenie meniča zmenou jeho pracovnej frekvencie. Menič sa vyznačuje spínaním pri nulovom napätí (ZVS) a vypínaním pri redukovanom prúde pre hlavné polovodičové spínače a komutáciou pri nulovom prúde pre usmerňovacie diódy. Tieto vlastnosti predurčujú menič pre IGBT, pričom sa môže dosiahnuť vyššia pracovná frekvencia s relatívne pomalými prvkami. Predpokladaná účinnosť meniča je vysoká počas malej aj veľkej záťaže, pričom rozsah výstupného napätia je dvojnásobný oproti konvenčnému polomostovému sériovému rezonančnému meniču. Jadro článku pozostáva z PSpice modelov jednotlivých častí meniča a zo simulačných výsledkov, ktoré boli dosiahnuté ich použitím.

A control circuit for a new high-frequency DC-DC converter, suitable for application in a few kilowatts range, is presented. The converter topology is based on a half bridge series resonant converter, i. e. having only two switches. Resonance occurs only for a part of each switching cycle, and a discrete energy pulse is transferred to the load every half cycle, rendering a variable frequency controller for controlling the output power. The converter features zero-voltage turn-on and snubbed turn-off at reduced current for the switching devices, and zero current commutation of the rectifier diodes, making it suitable for IGBT switches operating at a switching frequency higher than 20 kHz. The efficiency of the converter is supposed very high under full load and low load conditions, while the dynamic output voltage range is two times larger than that of the conventional half bridge Series Resonant Converter. PSpice Model presents the entire converter and control circuit.

### 1. Introduction

In a number of applications, such as battery chargers and traction, the static power converter operates at full load for a small proportion of an operating cycle. Though most full load efficiencies are high in modern switch mode power converters, the efficiency drops significantly under small load conditions, and the overall efficiency over the full cycle can be low. This phenomenon can be attributed to transformer magnetization losses, switching losses, and for most resonant and/or soft switching converters, additional conduction losses due to circulating currents. In addition, when charging totally discharged batteries, the voltage must be increased, and a specified current has to be provided before the voltage reduces to its normal value and full load current is applied. Commercial battery chargers (50/60 Hz ferro-resonant technology) cannot provide any current at a sufficiently large voltage, and it is consequently not possible to charge batteries in the mentioned condition. Furthermore, if a square wave converter such as a half bridge converter should be used and be designed to provide a sufficiently high output voltage, it will operate under a low switching duty cycle at full power output. This will lead to poor

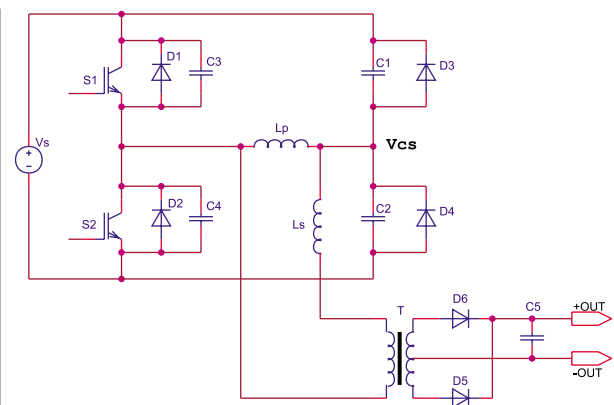

Fig. 1 Power circuit

full load efficiency because of the bad utilization of the semiconductor switches, especially when using MOSFET's. This problem is also commonly encountered with modern DC welding power supplies, where a high voltage is required to draw an arc, while a lower output voltage is required during welding.

\* MSc. Ivan Feňo, MSc. Eduard Jadroň, Associate Professor Pavol Špánik, PhD.

Department of Electrical Traction and Energetics, Faculty of Electrical Engineering, University of Žilina, Veľký diel, 010 26 Žilina, Slovak Republic,  
Tel.: +421-41-565 2231, 565 2231, 513 2175  
E-mail: feno@kete.utc.sk, ej@edo.spsmt.sk, spanik@fel.utc.sk

## 2. The ZVS Partial Series Resonant Converter (PSRC)

The PSRC is a new variation of the well-known Series Resonant Converter (SRC) in the half bridge configuration. The only topological differences are the addition of a clamping diode parallel to each of the two resonant capacitors, and the inclusion of a parallel inductance  $L_p$ , as shown on Fig. 1. The clamped capacitor voltage limits the voltage stresses of the capacitors, which is an important improvement regarding cost and reliability, especially at higher power levels.

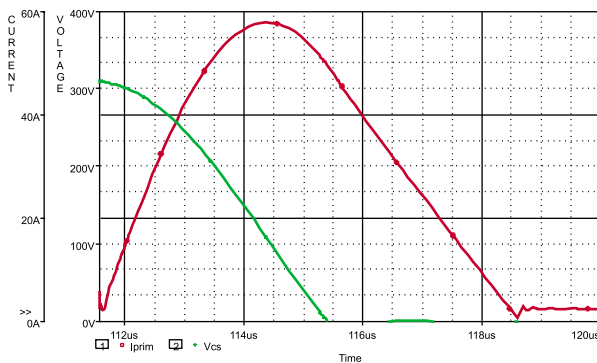

Fig. 2 Voltage  $V_{cs}$  and  $I_{prim}$  current in PSRC circuit

The additional parallel inductance  $L_p$  is used to commutate voltage  $V_d$  when both switches ( $S_1$  and  $S_2$ ) are turned off, and therefore obtaining ZVS. In the conventional SRC, ZVS can only be achieved with the switching frequency always higher than the resonant frequency of the resonant tank ( $L$  and  $C$ ).

This requires either a high switching frequency or large reactive components, when considering that the switching frequency has to be varied over a large range to have sufficient control of the output power, with the minimum switching frequency at 20 kHz. The PSRC, however, achieves ZVS with the switching frequency always lower than the resonant frequency of the resonant tank ( $C_1$ ,  $C_2$  and  $L_s$  in Fig. 1), resulting in a significant reduction in size of the reactive components, and of the transformer.

Switching conditions are very favorable for diodes  $D_3$  and  $D_4$ , since the large resonant capacitors,  $C_1$  and  $C_2$ , effectively act as snubbers. The rectifier diodes,  $D_5$  and  $D_6$ , experience very low switching losses due to the sinusoidal transformer current, resulting in soft switching for all semiconductor devices in the power circuit. Therefore, slower and cheaper devices could be used at high switching frequency ( $> 50$  kHz).

The main feature of the ZVS PSRC operation is the fact that  $V_{cs}$  swings from  $V_s$  to zero volts, or vice versa, during every half-switching cycle. The resulting voltage and current waveforms for the half-switching cycle with  $S_2$  being switched on are as shown in Fig. 2. Note that the initial condition for  $V_{cs}$  for this particular half-switching cycle is  $V_{cs} = V_s$ .

The first part of a switching cycle consists of a resonance interval with current being conducted by the two resonant capacitors ( $C_1$  and  $C_2$ ),  $L_s$ ,  $L_p$  and  $S_2$ . First part is followed by the discharging interval during which the energy stored in  $L_s$  is discharged into the combination of  $C_5$  and the output. Lastly, there is the freewheeling interval during which  $S_2$ ,  $D_4$  and  $L_p$  only conduct current. Turn-off of  $S_2$  can occur during the freewheeling

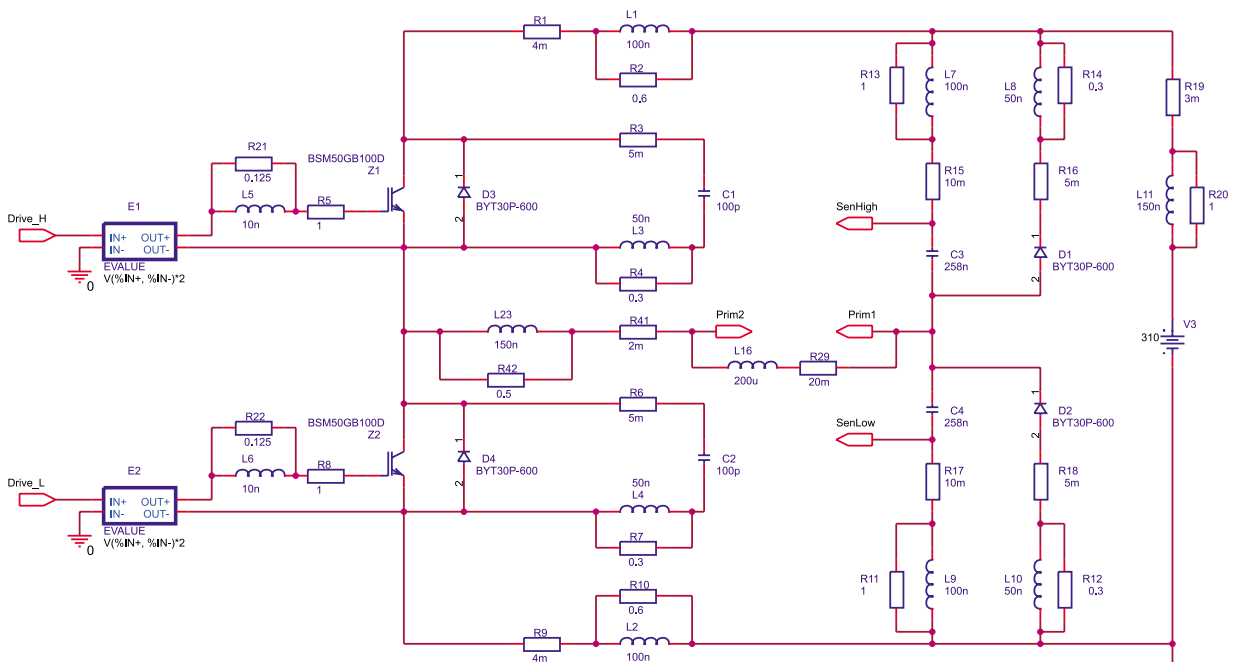

Fig. 3 Primary part simulation model schematic

interval, with commutation of the switch current to C3 and C4, resulting in low turn-off losses. C3 and C4 will therefore conduct  $I_{prim}$  until D1 clamps  $V_d$  to  $V_s$  and S1 can then be turned on, obtaining ZVS. All the energy stored in the resonant capacitors, C1 and C2, will therefore be transferred to the output each time the two switches are commutated (i.e. every half-switching cycle). This results in the (1) equation for the output power, where  $f_s$  is the switching frequency. The average output power is controlled by simply varying the switching frequency, provided that  $V_{cs}$  does a full excursion between the positive and the negative supply during each half switching cycle, while C1 and C2 resonate predominantly with  $L_s$ .

$$P_{OUT} = (C_1 + C_2)V_s^2 f_s \quad (1)$$

The latter implies that the output voltage  $V_{out}$  must be lower than half the supply voltage  $V_s$ , when assuming normalized transformer turns ratio. The parallel inductance  $L_p$  is much larger than the series inductance  $L_s$ . Inductors,  $L_s$  (the leakage inductance) and  $L_p$  (the magnetizing inductance), and the transformer (T) are

integrated into one physical structure, resulting in a minimum number of components.

At high output voltages, i.e. when  $V_{cs} > V_s/2$ ,  $V_{cs}$  is partly resonated by  $L_p$  at reduced frequency, and the output power is therefore reduced. Under no load conditions,  $V_{cs}$  is commutated by  $L_p$  alone, and the output voltage  $V_{out}$  is then equal to the supply voltage  $V_s$ , divided by the transformer turns ratio.

### 3. The Control Circuit Description

Based on operational principles and welding requirements, control circuit has been designed and all the power part and control part simulation models has been built for PSpice A/D software. Fig. 5 presents control part, Fig. 3 shows primary power part and secondary part is shown on Fig. 4. To "time" the circuit, voltage controlled ramp generator is used that employs operational amplifier integrator. When ramp reaches certain voltage level, a comparator changes its state and switching devices commutation can occur. In this moment, ramp generator is reset and next cycle starts

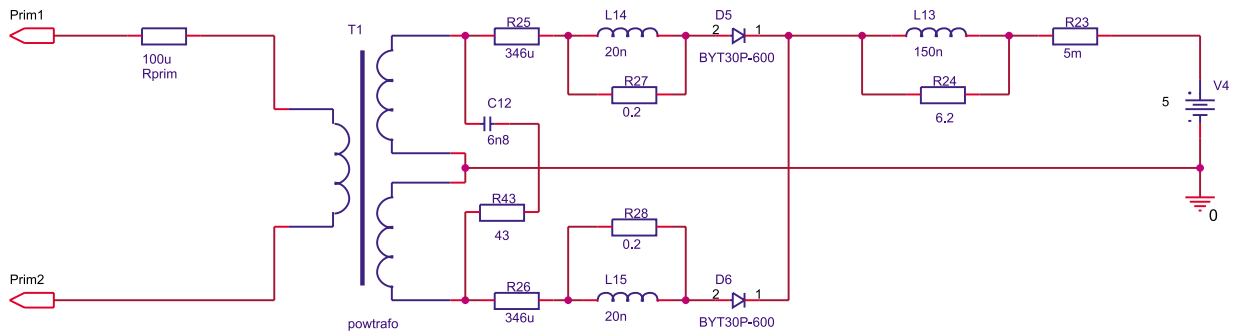

Fig. 4 Secondary part simulation model schematic

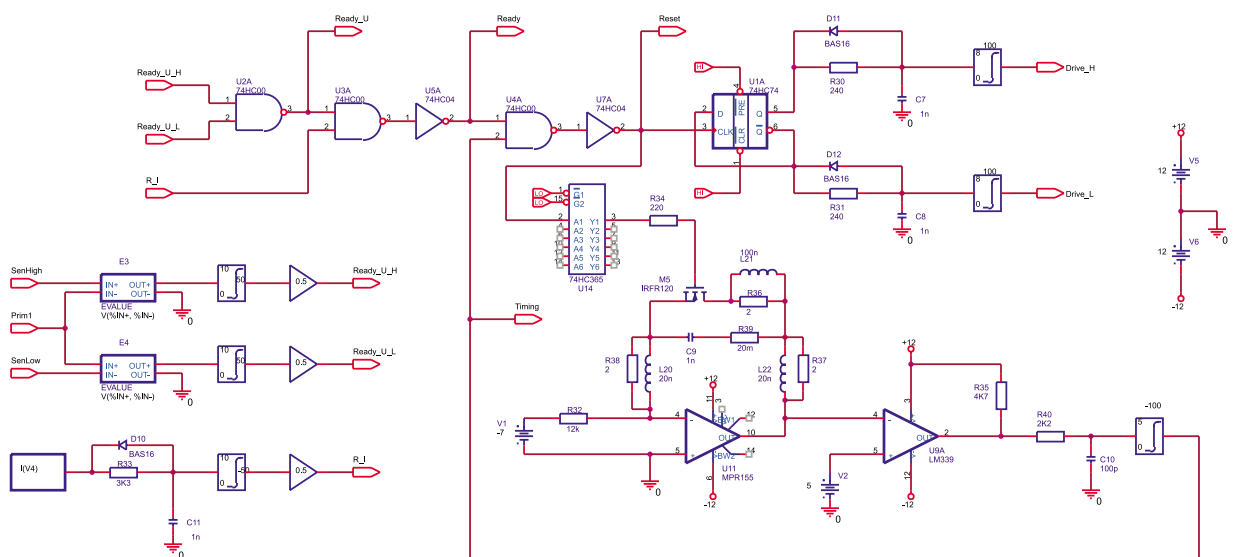

Fig. 5 Control part simulation model schematic

circuit timing. The slope of the ramp is defined by control voltage that in turn determines switching frequency, and hence, output power of the converter.

However, in the case of light load condition,  $V_{cs}$  voltage doesn't exhibit full transient from  $V_s$  to zero (and vice versa) before timing is finished and, hence, commutation has to be delayed to obtain a full energy pulse conversion. Therefore, the circuit features a voltage checking part, which tracks  $V_{cs}$  voltage (Fig. 5, 3). Due to this fact, a reset signal for the ramp generator is gated by "Ready-V" signal.  $V_{cs}$  checking part that has been mentioned above provided this signal.

Next, in a heavy load condition, output current doesn't decrease so fast and circuit timing is finished before current in power switches decays to zero. The circuit has therefore next watching part for output current tracking which generate "Ready-I" signal. This signal provides delay to ramp reset too and ensures zero current state for commutation.

#### 4. Circuit waveforms

A simulation model for power circuit consisting of a primary and secondary power part in conjunction with a control circuit has been designed and built for PSpice A/D software.

Left side part on Fig. 6 shows  $V_{cs}$  voltage and rectified current (rectifier diodes current sum). Right side part presents voltage across and current through  $S1$ . Waveforms are valid for output voltage equaled to 0.31 times supply voltage  $V_s$  (transformer turns ratio  $N1/N2 = 4$ ). In this case  $V_s = 310$  V,  $V_{out} = 24$  V,  $I_{out} = 97$  A, switching frequency  $f_s = 55$  kHz. Peak switch current reaches 58 A; voltage across switch doesn't pass 320 V. Peak output rectifier current reaches 215 A; current downslope value is 55 A/ $\mu$ s. A commutation interval is determined by timing circuit therefore switching frequency is constant if load is lightly changed.

Fig. 7 presents the same waveforms as previous figure but output voltage  $V_{out}$  is forced to 5 V. Other values are  $V_{in} = 310$  V,  $I_{out} = 135$  A, switching frequency  $f_s$  is set to 26 kHz by current

tracking circuit that delays reset signal for integrator circuit since switch current decays slowly. Peak switch current reaches 72 A; voltage across switch doesn't pass 321 V. Peak output rectifier current reaches 283 A; current downslope value is 21 A/ $\mu$ s.

Fig. 8 shows the waveforms for output voltage  $V_{out}$  forced to 60 V. Other values are  $V_{in} = 310$  V,  $I_{out} = 19$  A, switching frequency  $f_s$  is 26.1 kHz due to voltage tracking circuit that checks  $V_{cs}$  for full swing from  $V_s$  to zero and vice versa. Peak switch current is 18 A; voltage across switch doesn't pass 320 V. Peak output rectifier current reaches 85 A; current downslope value is 39 A/ $\mu$ s.

#### 5. Conclusion

The Zero Voltage Switching Partial Series Resonant Converter provides the following advantages for use in arc welding applications, when being compared with present technology being used in commercial inverter welders:

- High open circuit voltage, equal to the supply voltage  $V_s$  when assuming a normalized transformer turns ratio.
- 50 % switching duty cycle with an output voltage lower than half  $V_s$ , with normalized transformer turns ratio.
- Very low conduction and switching losses due to ZVS, and sinusoidal switch current, resulting in snubbed turn-off at reduced current
- Obtain ZVS with the switching frequency lower than the resonant frequency, reducing the size of all the active components, including the transformer.
- Sinusoidal transformer current, minimizing copper losses.
- Low switching losses for the clamping diodes and for the rectifier diodes, further reducing semiconductor losses.
- Naturally constant power load line when the output voltage is less than half  $V_s$  (normalized transformer turns ratio).

In contrast to almost all commercial DC welders, the output of the PSRC is derived from a capacitor. This results in the fastest possible current rise rate at arc initiation, because the inductance of the welding cables is the only component that limits the rate of rise of the output current.

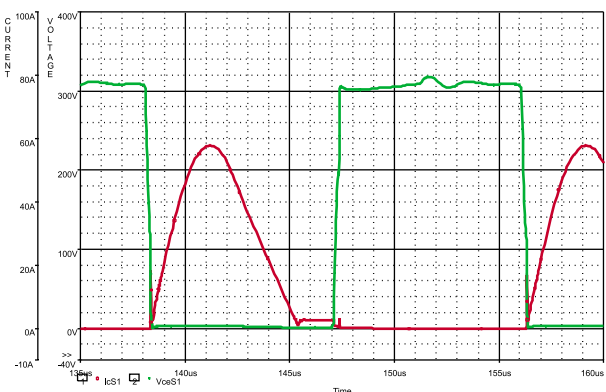
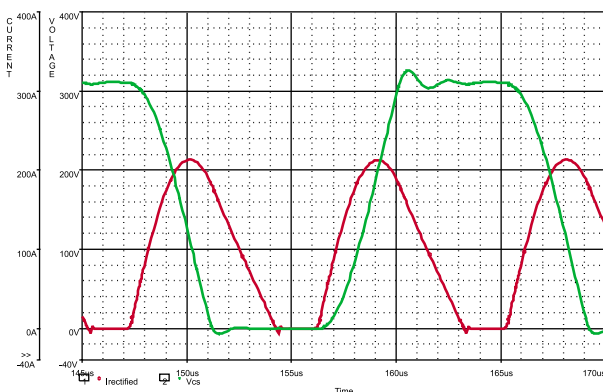

Fig. 6 Key waveforms for  $V_{out} = 24$  V

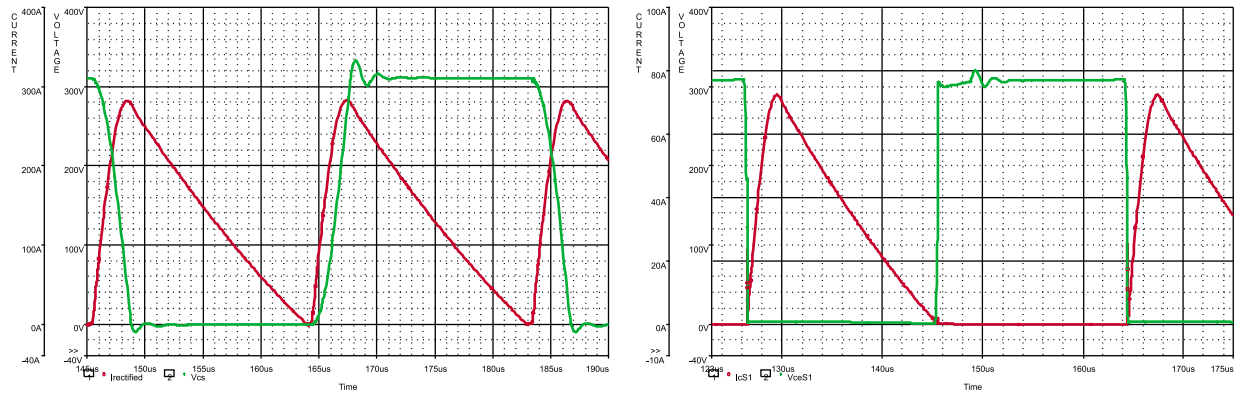

Fig. 7 Key waveforms for  $V_{out} = 5\text{ V}$

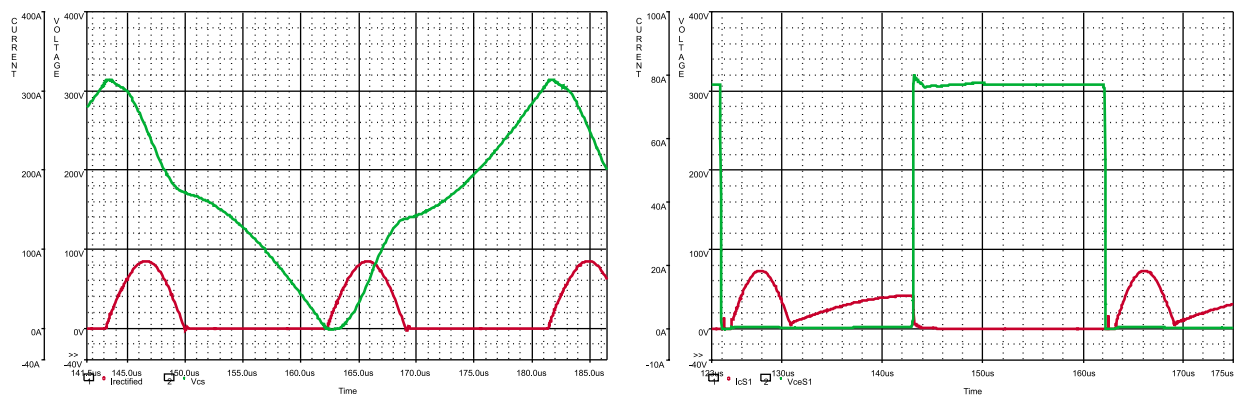

Fig. 8 Key waveforms for  $V_{out} = 60\text{ V}$

## 6. References

- [1] Theron, P. C., Ferreira, J. A.: "A new Partial Series Resonant Converter for efficient DC to DC conversion" PCC Yokohama Proceedings, Tokio, Japan, April 1993, pp 171-176
- [2] Theron, P. C., Ferreira, J. A.: "The Partial Series Resonant Converter: A new DC to DC converter with good light load efficiency". IEEE-IAS Conference, 1993
- [3] Kováčová, I., Kováč, D.: *Výkonové tranzistory MOSFET a IGBT*, ELFA, Košice 1996
- [4] Dzurko, P., Dudrik, J., Vyšňny, P.: "Behavior of Arc Welder with high frequency LCC resonant Converter", EPE-PEMC - 2000 Conference, Košice

Rastislav Kuliha \*

# PRINCÍPY ZNIŽOVANIA RIZIKA

## RISK REDUCTION PRINCIPLES

*Uvedené princípy sú spôsoby overovania miery rizika pre spojité systémy, s časovými vzorkami pre pozorovanie stavu systému. Navrhnutá neuronová sieť kopíruje plochú funkciu výkonu, na ktorú sú aplikované niektoré štatistické postupy pre zisťovanie miery spoľahlivosti.*

### 1. Úvod

Každá činnosť, ktorej sa človek venuje, prináša istú mieru rizika pre neho, aj pre jeho okolie. Jej veľkosť sa dá ovplyvniť na úrovni fyzikálnych dejov v systéme. Svoj význam má tiež štatistický model.

### 2. Funkcia stavu a výstupná funkcia

Všetky dynamické systémy sa dajú opísať sústavou rovníc (1.1). V kritickej oblasti je  $A(t, \mathbf{x}, \mathbf{u}) < 0$ , nezávisle od  $\mathbf{u}$ , pri podmienke, že  $\mathbf{x}$  je vychýlené z  $\mathbf{x}_M$  (hranica bezpečnej oblasti) o viac ako  $\epsilon$ .

$$\frac{d\mathbf{x}}{dt} = A(t, \mathbf{x}, \mathbf{u}) \quad (1.1)$$

$$\mathbf{Y} = \mathbf{C} \cdot \mathbf{x} + \mathbf{D} \cdot \mathbf{u}$$

Je to požiadavka inherentnej bezpečnosti, teda že systém by sa mal brániť vonkajším nepriaznivým vplyvom riadenia a samovoľne začať znižovať energiu v určitom stupni svojho vývoja, ak má vlastnosť bezpečnosti vrodenu. Ak sa systém považuje za lineárny v určitom čase  $i, \delta$ , s maticami  $\mathbf{A}$  a  $\mathbf{B}$  pre prvú rovnicu (1.1) a stav  $\mathbf{x}$  je odvodzovaný z výstupnej premennej  $\mathbf{Y}$ , pri súčasnom pôsobení neželanej väzby výstupu na riadenie  $\mathbf{u}$ , označeného ako matica  $\mathbf{D}^p$ , rozdiel  $\epsilon$  medzi dvomi po sebe pozorovanými vektormi  $\mathbf{Y}$  je podľa (1.2).

Pri procese riadenia reťazovej reakcie je bezpečný stav systému pri minimálnom výkone, ale je tu najväčšie riziko prechodu reaktora do kritického stavu na okamihových neutrónoch, so strednou dobou života  $l_s$ . Zjednodušená rovnica pre nárast počtu neutrónov  $n$ , pri koeficiente reaktivity  $k_{ef}$ , je podľa (1.3). Je to rovnica nezhromažďujúca absorpčné mechanizmy, pozri [1].

$$\epsilon(i+1) = \delta \cdot \mathbf{C} \cdot \mathbf{A} \cdot \mathbf{x}(i) + \delta \cdot \mathbf{C} \cdot \mathbf{B} \cdot \mathbf{u}(i) + \mathbf{D}^p \cdot (\mathbf{u}(i+1) - \mathbf{u}(i)) \quad (1.2)$$

*Various ways are applied for the attestation of a risk degree for a continuous system, with time samples for observation of the state. The neural network has been designed. The parameters of reliability have been calculated for flat power function.*

### 1. Introduction

Every human activity brings about risk not only for the subject involved in it but also for its environment. A degree of risk can be influenced respecting physical actions in the system. The statistical model has also its importance.

### 2. State function and output function

All dynamic systems can be described by a set of equations (1.1). In a danger zone there is a transition matrix  $A(t, \mathbf{x}, \mathbf{u}) < 0$  independently on  $\mathbf{u}$ , on condition that  $\mathbf{x}$  is deflected from  $\mathbf{x}_M$  (border of safe area) more than allowed.

$$\frac{d\mathbf{x}}{dt} = A(t, \mathbf{x}, \mathbf{u}) \quad (1.1)$$

$$\mathbf{Y} = \mathbf{C} \cdot \mathbf{x} + \mathbf{D} \cdot \mathbf{u}$$

This is an inherent safety demand. The system should resist outside negative command impacts. Next it should spontaneously begin to scale down energy, by which to pass to a safer state. For the first equation (1.1) the system which can be considered approximately as linear in certain time  $i, \delta$ , is described as  $\mathbf{A} \cdot \mathbf{x} + \mathbf{B} \cdot \mathbf{u}$ . State  $\mathbf{x}$  is derived from the output variable  $\mathbf{Y}$ . The difference  $\epsilon$  between two consecutive vectors  $\mathbf{Y}$  with consideration for output effects of unwanted control coupling  $\mathbf{D}^p$  is according to (1.2).

The process of control of a chain reaction isn't in a safe state if the reactor works on the minimum power [1]. Since the danger that reactor passes to the critical state on prompt neutrons with a mean life  $l_s$  is the highest. It is necessary to control the system carefully in this period. A simplified equation for accumulation of thermal neutrons  $n$  if reactivity factor is  $k_{ef}$ , is expressed in equation (1.3). It is an equation which includes no absorptive mechanics.

\* Ing. Rastislav Kuliha

Department of Information and Safety Systems. Faculty of Electrical Engineering, University of Žilina, Veľký diel, NF-307, 010 26 Žilina, Slovak Republic, Tel.: +421-41-5133251, E-mail: kuliha@fel.ute.sk

$$\frac{dn}{dt} = \frac{k_{ef} - 1}{l_s} n \quad (1.3)$$

Chybná informácia o počte tepelných neutrónov  $n$  a zásah riadenia, napr. zmena  $k_{ef}$  z 1 na 1,01 ak je pomer okamihových neutrónov k tepelným vyšší, a teda aj  $l_s$  menšia, napr.  $10^{-5}$ , má za následok taký nárast  $n$ , že reaktor sa stane neriaditeľný. Vychádza z toho maximálna rýchlosť posunu regulačných tyčí a inherentné vlastnosti bezpečnosti, ako je pokles reaktivity  $k_{ef}$  s teplotou, tiež zmierňujú nárast výkonu.

### 3. Statický model sériového koľajového obvodu

Vlastnosť inherentnej bezpečnosti nemusí byť postačujúca. Je dôležité znížiť pravdepodobnosť jeho zlyhania. Pri úvahe o bezpečnosti sústavy je potom dôležitá jej základná logická funkcia, bez dynamických zmien. V dvojrozmernom priestore sa dá analyzovať model sériového koľajového obvodu (obr. 1). Správanie je závislé od sily  $F$ , pôsobiacej na návěstné relé, s hraničnou hodnotou pre príťah  $F_h$  a prúdu prechádzajúceho koľajovým obvodom  $J$ . Jeho hodnoty pre pritiaženie a odpadnutie kotvy sú  $J_{min}$  a  $J_{max}$ , pre relé  $J$ . Ak je sila  $F$ , väčšia ako  $F_h$ , svieti zelená. Ak je prúd  $J$  väčší ako  $J_{min}$ , znamená to prítomnosť vlaku. Sila  $F$ , stlačenia kontaktov relé  $N$ , by mala byť potom menšia ako  $F_h$ .

Každému bodu stavového priestoru sa dá priradiť úroveň bezpečnosti. Nie je náročné zostaviť takéto priradenie a odhadnúť systém majúci rovnakú funkciu, ktorého štruktúra je odhadnutá a parametre vypočítané z množiny pozostávajúcej z  $n$  dvojíc  $m$ -rozmerných vstupných a im zodpovedajúcich  $k$ -rozmerných výstupných vektorov. Z tréningovej množiny sa dajú odhadnúť váhy a prahy neurónovej siete (NN), kritériom minima energie  $E$ . Tvori ju súčet rozdielu štvorcov (2.1) medzi skutočnou hodnotou  $S_i$  a očakávanou hodnotou výstupu  $O_i$ . Štruktúra s 2 neurónmi v skrytej vrstve s prahmi  $v_j$ , a 1 výstupným, s prahom  $\phi$ , a váhami synáps  $w_{oj}$  a  $v_{ij}$  je na obr. 2.

$$z_1 = t(\vartheta_1 + v_{11}f + v_{21}j)$$

$$z_2 = t(\vartheta_2 + v_{22}f + v_{21}j)$$

$$\frac{dn}{dt} = \frac{k_{ef} - 1}{l_s} n \quad (1.3)$$

A false report about the number of thermal neutrons  $n$  along with a bad intervention of the control system can cause that it will be impossible to restrict the chain reaction, e.g. by the  $k_{ef}$  change from 1 to 1.01. Considering that the ratio between prompt neutrons and thermal neutrons is higher than allowed then the  $l_s$  is less, e.g.  $10^{-5}$ , the accumulation  $n$  in a time unit is very abrupt. The reactor begins to be uncontrollable. That can be seen in (1.3). But properties of an inherent safety as loss of reactivity with temperature, mitigate the accrual of power. The mechanism of the active safety can be defined by the equation (1.3) - limitation of speed of regulation bars.

### 3. A static model of a serial railway track circuit

The property of the inherent and active safety needn't always be sufficient for the global safety. It needs also monitoring of the system reliability. It means to determine its break down possibility. It is important considering the safety the basic logic function without dynamic alterations. A serial railway track circuit model can be analysed with regard to two variables  $F$  and  $I$ . This model is shown in Fig. 1.

Behaviour of this system depends on the force  $F$  which acts at a signal relay with a limit account for the ballast  $F_h$  and on the current  $I$  that flows through the circuit. Its values for pull and defection of the relay  $J$  are  $I_{min}$  and  $I_{max}$ . If its force  $F$  is above the measure  $F_h$ , the green signal must be flared. If  $I$  is greater than  $I_{min}$ , that represents a train's attendance. Afterwards the force  $F$ , which presses the contact of the relay  $N$  should be less than  $F_h$ .

A safety level can be assigned to any point of a state space. It isn't difficult to arrange a function determining a level of safety of every point at the state space. That function can be realised, for instance, by the system, whose structure was adjusted and the arguments were calculated from the aggregate  $N$  couple  $m$ -dimensional input and  $k$ -dimensional output vectors corresponding to them.

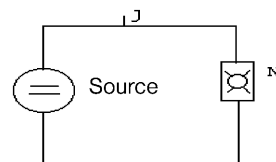

Obr. 1. Kontakt relé  $J$ , ktoré vypína zelené svetlo

Fig. 1. Contact relay  $J$  that open green light

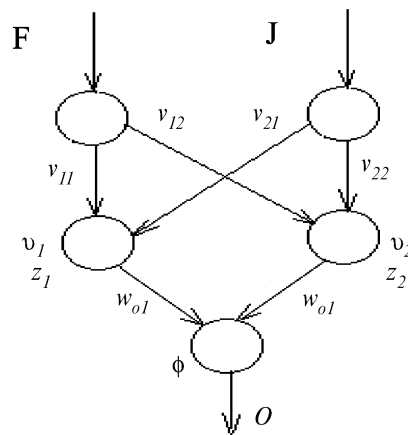

Obr. 2 NN, s výstupmi 2. vrstvy  $z_1$  a  $z_2$

Fig. 2 NN, with output of second layer  $z_1$  and  $z_2$

$$z_1 = t(\vartheta_1 + v_{11}f + v_{21}j)$$

$$z_2 = t(\vartheta_2 + v_{22}f + v_{21}j)$$

$$E = \frac{1}{2} \sum_{k=1}^n (S_k - O_k)^2 \quad (2.1)$$

$$t(x) = \frac{1}{1 + \exp(-x)}$$

$$S = t(\varphi + w_{1o}z_1 + w_{2o}z_2)$$

$$E = \frac{1}{2} \sum_{k=1}^n (S_k - O_k)^2 \quad (2.1)$$

$$t(x) = \frac{1}{1 + \exp(-x)}$$

$$S = t(\varphi + w_{10}z_1 + w_{20}z_2)$$

Zmena veľkostí prahov  $\varphi$  v  $i+1$ . kroku môže prebiehať podľa (2.2),  $\mu$  je momentový člen ( $\mu = 0.5 \div 0.7$ ),  $\lambda$  je rýchlosť učenia ( $\lambda \cong 0.1$ ). Rovnako sa postupovalo pri výpočte ostatných prahov a váh.  $E$  je nutné najskôr derivovať podľa  $S$ , potom podľa  $\varphi$ , ako závislú premennú. Viac je možné sa dozvedieť v [3].

$$\varphi^{i+1} = \varphi^i - \lambda \frac{\partial E_i}{\partial \varphi} + \mu \cdot (\varphi^i - \varphi^{i-1}) \quad (2.2)$$

#### 4. Funkcia výkonu G

Systém je v stavovom priestore v bezpečnom stave, ak je jeho funkcia výkonu  $G$  kladná. Pravdepodobnosť nebezpečného stavu je definovaná podľa [4] ako (3.1).

$D$  je priestor, v ktorom je  $G$  kladná. Pre koeficient spoľahlivosti  $\beta$  platí (3.2):

$$p_f = p(G(X) < 0) = \int_D f_X(X_1, X_2, \dots, X_n) \cdot dx_1 dx_2 \dots dx_n \quad (3.1)$$

$$\beta = \frac{E(G(X))}{\sigma_{G(X)}} \quad (3.2)$$

$E$  je stredná hodnota funkcie  $G$ ,  $E(G(X)) = G(m_1, m_2, \dots, m_n) = G(\mathbf{m})$  uvažovaná ako jej veľkosť pre bod  $\mathbf{m}$ , ktorý je strednou hodnotou stavového priestoru.

$$\sigma_{G(X)}^2 \cong \sum_{j=1}^n \sum_{i=1}^n \left| \frac{\partial G(X)}{\partial X_i} \frac{\partial G(X)}{\partial X_j} \rho(X_i, X_j) \right| \quad (3.3)$$

$\sigma_{G(X)}$  je rozptyl a  $\rho(X_i, X_j) = E[(X_i - \bar{X}_i) \cdot (X_j - \bar{X}_j)]$  je koeficient kovariácie [2].

Ak je v priestore  $X$  možné uvažovať hladkú funkciu  $G$ , sústavu je možné opísať sigmoidálnou funkciou výkonu, napríklad podľa (3.4).

$$G(x) = \sum_{i=1}^N u_i \prod_{j=1}^n \frac{1}{1 + S_{jin} e^{x_j - x_{ji} \min}} \frac{1}{1 + S_{jix} e^{-(x_j - x_{ji} \max)}} \quad (3.4)$$

$$\frac{\partial G(x)}{\partial x_k} = \sum_{i=1}^N u_i \frac{S_{kix} e^{-x_k + x_{k \max}} - S_{kin} e^{-(x_k + x_{ki} \min)}}{(1 + S_{kix} e^{-x_k + x_{k \max}}) \cdot (1 + S_{kin} e^{-(x_k + x_{ki} \min)})} \prod_{j=1}^n \frac{1}{1 + S_{jix} e^{-(x_j - x_{ji} \max)}} \frac{1}{1 + S_{jin} e^{x_j - x_{ji} \min}} \quad (3.5)$$

$n$ : rozmernosť priestoru, na ktorom je definovaná funkcia  $G$ ,  
 $N$ : počet oblastí, na ktorých je funkcia  $G$  definovaná svojou úrovňou,  
 $u_i$ : veľkosť funkcie  $G$  na oblasti  $i$  je kladná alebo záporná, podľa rizika,  
 $S_{jin}$ : príznak nárastu prierezu v  $i$ -tej oblasti v smere osi  $j$ ; ak existuje skok  $u_{imin} \rightarrow u_{imax} \Rightarrow S_{jin} = 1$ , inak je 0

The balances and bias of neural network (NN) can be adjusted from the training set (NN) by the criterion of the mini power  $E$ . Therefore, the energy contains the sum of square differences between the actual output  $S_i$  and anticipation sample  $O_i$  from the training set, according to (2.1). If there are more specimens than the total energy is sum of energy for all specimens. Fig. 2 gives us the structure with two neurons in a hidden layer with bias  $v_i$ , one neurons in a output layer, with the biasmeasures  $\varphi$ , if the balances of synapses are  $w_{ij}$  and  $v_{ij}$ . The relationship between the bias mass  $\varphi$  at  $i+1$  and at  $i$  in every time step is by (2.2). The sign  $\mu$  is a cell of moment ( $\mu = 0.5 \div 0.7$ ) and the  $\lambda$  is a rate learning ( $\lambda \cong 0.1$ ). The other bias and balances must be calculated as well but they must be in (2.2) instead of  $\varphi$ . The trouble is that we must differentiate  $E$  at first after  $S$  and afterwards after  $\varphi$ , respectively  $w_{ij}$ ,  $v_{ij}$  or  $\vartheta$  as a dependent variable. It needs to come on like that for the calculation of the parameters by a back propagation method. More about that can be seen in [3].

$$\varphi^{i+1} = \varphi^i - \lambda \frac{\partial E^i}{\partial \varphi} + \mu \cdot (\varphi^i - \varphi^{i-1}) \quad (2.2)$$

#### 4. The Power function G

This method was applied also in [4]. The system situated in a safety status at a state space, if its power function  $G$  is positive. The probability of its transition to a dangerous state  $p_f$  (3.1) and the reliability coefficient  $\beta$  (3.2) are defined in the following way:

Let  $E$  be a mean value of the power function  $E(G(X)) = G(m_1, m_2, \dots, m_n)$  and  $\mathbf{m}$  a vector mean values of components from the state space.

$\sigma_{G(X)}$  is a dispersion of the variable  $X$ ,  $\rho(X_i, X_j) = E[(X_i - \bar{X}_i) \cdot (X_j - \bar{X}_j)]$  is the covariation coefficient [2]. The safety of the system can be defined by the exponential power function (3.4).

$S_{jix}$ : priznak poklesu prierezu v  $i$ -tej oblasti v smere osi  $j$ ; ak existuje skok  $u_{imax} \rightarrow u_{imin}$ , inak je  $S_{ix} = 0$ .

Pre funkciu na obr. 4 a oblasť ( $F > F_h, J < J_{min}$ ), na obr. 3 je  $i = 4$ . Teda  $S_{J4n} = S_{F4n} = 1, S_{J4x} = S_{F4x} = 0$ . Ale pre  $i = 3$ , ( $F < F_h, J > J_{min}$ ), je  $S_{J3n} = 0, S_{J3x} = 1, S_{F3n} = 1, S_{F3x} = 0$ .

$x_{ji \min}, x_{ji \max}$ : body na osi  $j$ , v ktorých nastáva prechod  $u_i u_{imax} \rightarrow u_{imin}$  resp.  $u_{imin} \rightarrow u_{imax}$ .

Pre tento prípad je počet oblastí  $N = 5$  a existujú dve stavové premenné  $F$  a  $J$ , teda  $n = 2$ , pričom hodnoty funkcie  $G$  môžu byť podľa obr. 3.

Funkcia výkonu  $G$  podľa (3.4) je na obr. 4. Je východiskom pre NN so 6 skrytými neurónmi, ak vstupné vzory sú z priestoru  $(J,F)$ . Odozva skutočnej NN je na obr. 5. Chyba  $E$  bola ako na obr. 6. Najvhodnejšie je zvýšiť čas výskytu systému v bode  $(0,10)$  priestoru  $(J,F)$ , (obr. 7). Taký

$I_{\min}$	+	-
$I_{\max}$	+ -	+
	+ - -	+

$F_h$

Obr. 3 Hodnoty funkcie  $G$ . Podľa počtu znamienok „+“ a „-“ je určená približná veľkosť funkcie výkonu  
Fig. 3 Values of the power function  $G$ . It is according to number of signs

$S_{jix}$ : the decrease attribute for a cross section of the area  $i$  in direction of the axis  $j$ . If there is a jump  $u_{imax} \rightarrow u_{imin}$  for this area  $u_i \Rightarrow S_{jix} = 1$ .

For the function in Fig. 4 and area ( $F > F_h, J < J_{min}$ ), Fig. 3, is the number of the area  $i = 4$ . Thereafter  $S_{J4n} = S_{F4n} = 1, S_{J4x} = S_{F4x} = 0$ . But for area  $i = 3$ , ( $F < F_h, J > J_{min}$ ),  $S_{J3n} = 0, S_{J3x} = 1, S_{F3n} = 1, S_{F3x} = 0$ ,

$x_{ji \min}$ : the point in this axis  $j$  at which a jump  $u_{imax} \rightarrow u_{imin}$  is determined for  $u_i$ ; when we describe point  $x_{ji \max} : u_{imin} \rightarrow u_{imax}$ .

For this case is number of area  $N = 5$ , (3.4). There are two variables of state  $F$  and  $J$ , hence area dimension is  $n = 2$ , and values of  $G$  can be seen in Fig. 3.

Fig. 4 gives us the power function  $G$  by the formula (3.4). This function is a source for NN with 6 hidden neurons, if the input models are from its area  $(J,F)$ . The response of actual NN (Fig. 5) is not accomplished. The weights are in Tab. 1. The error  $E$  calculating in

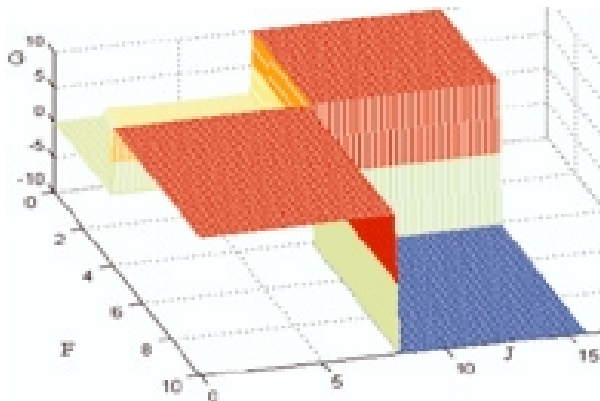

Obr. 4 Funkcia výkonu  $G$   
Fig. 4 Power function  $G$

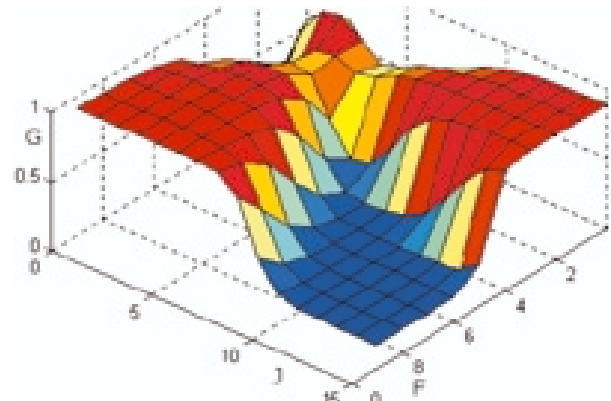

Obr. 5 Odozva NN pre 160 vzorov  
Fig. 5 NN reaction for 160 samples

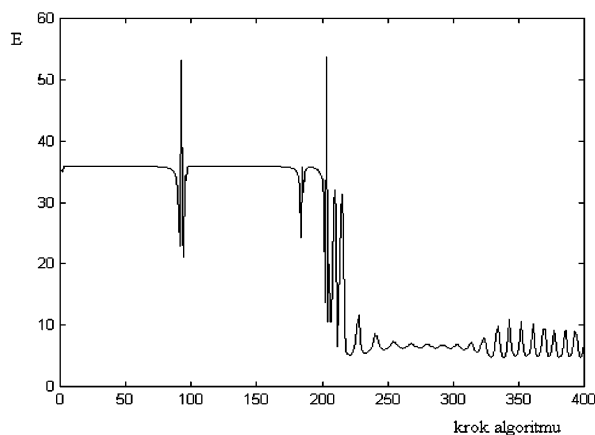

Obr. 6 Energia pre iterácie od 0 do 400  
Fig. 6 Energy for iteration for steps from 1 to 400

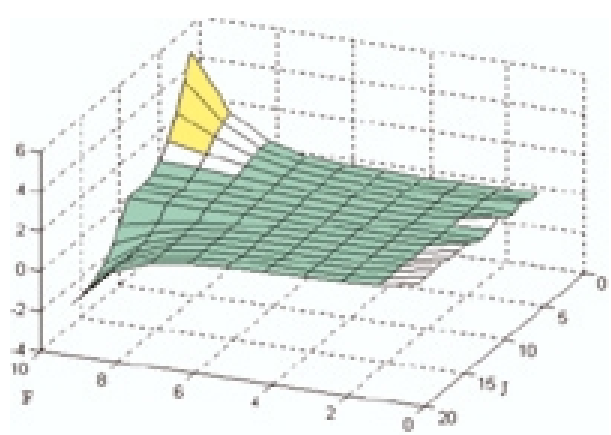

Obr. 7 Funkcia  $\beta$ , pri malom štatistickom rozptyle  
Fig. 7 Reliably coefficient  $\beta$  for a little statistical dispersion in every point

stav by bol z hľadiska spoľahlivosti najpriateľnejší, ale prevádzka by bola slabá, stále by svietilo červené svetlo.

Výsledok algoritmu pre najoptimálnejšie váhy, ak sú začiatkové hodnoty zvolené z normálneho rozdelenia, je v tab. 1. Označenia sú ekvivalentné obr. 2, len počet skrytých neurónov je vyšší. V skrytej vrstve je 6 neurónov.

Parametre NN

Tab. 1

$w = (1.0287 \quad 0.9086 \quad 3.7054 \quad 2.4374 \quad 1.3019 \quad 3.5697)$ $v = -5.3882$ $v = \begin{pmatrix} -0.7918 & 0.6228 \\ -0.7364 & 0.5455 \\ 0.7354 & 0.9761 \\ -1.8929 & 0.8742 \\ -1.4530 & 1.1581 \\ 1.0960 & -4.1485 \end{pmatrix}$ $\varphi = (-1.0084 \quad -0.7046 \quad -4.6716 \quad 7.0999 \quad 0.8789 \quad 1.0774)$
---

## 5. Záver

Prvky aktívnej bezpečnosti zaručujú riadenie s dostatočnou rezervou pri neprítomnosti vrodenej bezpečnosti systému. Vychádza z pozorovania stavu. Matica  $D^p$  (1.2) môže byť príčinou skreslenia stavu systému pozorovaného na výstupe  $Y$ . Funkcia  $G$  zostavená podľa (3.4) je vhodná aj pre viac rozmerov a pre tréning viac ako dvojjstupových NN.

## 6. Literatúra - References

- [1] KLIK, F., DALIBA, J.: *Jaderná energetika*, ČVUT, Praha 1995
- [2] SADOWSKI, W.: *Matematická štatistika*, Alfa, Bratislava 1975
- [3] KVASNIČKA, V., KRÁL, A., FARKAŠ, I.: *Úvod do teórie neurónových sietí*, IRIS, Bratislava 1997
- [4] BENMANSOUR, A., ABDALLAH, MASROURI, et AUVINET, G.: *Analyse fiabliste du comportement axial des conduites d'assainissement*

all steps in the back propagation algorithm is in Fig. 6. The best for the reliability is to advance the time occurrence system at the point (0,10) of area (J, F), (Fig. 7). It is also little effective, because the action circuit is active in the area  $G > J_{min}$ . The exit from the algorithm, hence optimal balances, if the initial amounts of the values are from a normal distribution is in tab. 1. Marks are equivalent Fig. 2; only the number of the hidden neurons is higher. There are 6 units in the hidden layer.

Parameters of NN

Tab. 1

$w = (1.0287 \quad 0.9086 \quad 3.7054 \quad 2.4374 \quad 1.3019 \quad 3.5697)$ $v = -5.3882$ $v = \begin{pmatrix} -0.7918 & 0.6228 \\ -0.7364 & 0.5455 \\ 0.7354 & 0.9761 \\ -1.8929 & 0.8742 \\ -1.4530 & 1.1581 \\ 1.0960 & -4.1485 \end{pmatrix}$ $\varphi = (-1.0084 \quad -0.7046 \quad -4.6716 \quad 7.0999 \quad 0.8789 \quad 1.0774)$
---

## 5. Summary

The objectivity of observation of a real system state depends on the vector  $D^p$  in (1.2) which can cause distortion of the system state  $x$ . The attribute of inherent safety warrants mitigate a bad control. It is suitable to apply a neural network for a better safety supervision. The  $G$  function (3.4) is suitable for the point of the input for a training set.

Csaba Balázsi – Judit Pfeifer \*

# ŠTRUKTURÁLNE A MORFOLOGICKÉ VYŠETROVANIE STARNUTIA HYDRÁTU KYSLIČNÍKA WOLFRÁMOVÉHO PRI IZBOVEJ TEPLOTE V ALKALICKOM VODNOM PROSTREDÍ

## STRUCTURAL AND MORPHOLOGICAL OBSERVATIONS ON TUNGSTEN OXIDE HYDRATES AGED AT ROOM TEMPERATURE IN ALKALI CONTAINING AQUEOUS ENVIRONMENT

*V príspevku je analyzovaný proces starnutia zrn kysličníka wolfrámového ( $H_2WO_4 \cdot H_2O$ ) pri izbovej teplote pripravený metódami Freedmana [J. Am. Chem. Soc. 81 (1959) 38 B4.] ([Na] zvyšok < 10 ppm) a Zoherom a Jacobsonom [Kolloidchem. Beih. 28-6 (1929) 167] ([Na] zvyšok < 10 ppm). Porovnávajú sa tieto dve prípravné metódy a charakteristiky starnutia. Zistené boli vretenovité tvary - Zoherov typ zrn má silnú tendenciu k morfolologickej zmene závislej od veľkosti pH obklopujúceho vodného roztoku. Rastrovacía elektromikroskopia (SEM) a Fourierova transformačná interferenčná spektroskopia (FTIR), ktorej štúdie sú prezentované, ukazujú na vysokú štruktúrálnu a morfológickú stabilitu Freedmanovho typu zrn, čo môže byť zmenené prítomnosťou alkalických iónov. Bolo zistené tiež isté vmiešavanie katiónov.*

*The room temperature ageing process of tungsten oxide hydrate ( $H_2WO_4 \cdot H_2O$ ) grains prepared by the methods of Freedman [J. Am. Chem. Soc. 81 (1959) 3834.] ([Na]residual  $\leq 10$ ppm) and Zoher and Jacobson [Kolloidchem. Beih. 28-6 (1929) 167.] ([Na]residual  $\geq 100$ ppm) has been studied. A comparison between two preparation methods and ageing characteristics is given. It is found that spindle shaped - Zoher type grains have a strong tendency to morphological conversion depending on pH value of surrounding aqueous solution. Scanning electron microscopy (SEM) and Fourier transform infrared spectroscopy (FTIR) studies have shown that the high structural and morphological stability of Freedman type grains can be altered by presence of alkali ions. Moreover, some incorporation of cations was observed.*

### 1. Introduction

Tungsten oxide hydrates are important basic materials for the tungsten industry involving the production of carbides, hard metals, heavy metals and electronic materials [1]. Due to the wide interest in science and large applicability in modern technology, numerous investigations were made on them. Several decades earlier this compound was successfully nominated as the parent phase for metastable hexagonal tungsten oxide representing an optimal substance in intercalation chemistry [2]. Starting from the same basic material with considerably high level of persistent background chemical impurity (residual sodium) and deliberately added organic residue, besides the hexagonal form another metastable polymorph, the cubic tungsten oxide with enlarged stability range was prepared in our laboratory [4]. In the latest reports new interesting properties came to light of already realized or prospective tungsten compounds, which could be easily synthesized from tungsten oxide hydrates [5]. Localized high critical temperature ( $T_c$ ) superconductivity was found on the surface of sodium doped tungsten oxide by Levi et al, thus initiating a potential candidature for tungsten oxides among superconductive materials which could revolutionize transportation, communications and could have impact

to several branches of industry. All of these observations enhance the necessity to control the alkali content and to establish the role of alkali concerning preparation processes and properties of derivatives. Other up to date applications such as electrochromic, photochromic and gasochromic devices using tungsten oxide as the basic-active material have attracted worldwide interest in recent years [6, 7, 8, 9]. These phenomena are related to color changes induced in selected materials by reversible electro-, photo-, gasochemical processes. The color changes result from the generation of different electronic absorption bands in the visible region, which is correlated to redox states switching. In commercial production for example, electrochromic or photoelectrochromic (electrochromic/solar cell sandwich constructions) windows, variable reflectance (antidazzle) mirrors for automobiles are already realized applications [6]. However, still uncertainty remained relating the mechanism of chromism phenomenon, such as long-term degradation and sensitivity against environmental conditions [8, 10]. Electro-, photo- and gasochromic devices are realized mainly by thin film processing, assuring porous structures and columnar morphologies for insertion host, enhancing ion mobility. Comparing the properties of films with bulk materials (grains in powder form) may result in new, surprising facts [9]. Continuing our study

\* Csaba Balázsi, Judit Pfeifer

Research Institute for Technical Physics and Materials Science, Hungarian Academy of Sciences, Hungary, Budapest XII., Konkoly-Thege út 29-33.  
Mail to: H-1525 Budapest-114, P.O. Box 49, E-mail: balazsi@mfa.kfki.hu

on ageing tungsten oxide hydrate grains [11], in this paper we present results on long-term observations of tungsten oxide hydrate grains in aqueous environments containing various alkali ions  $\text{Li}^+$ ,  $\text{Na}^+$ ,  $\text{K}^+$  and  $\text{NH}_4^+$  with various concentrations.

## 2. Experimental method

*Zocher (Z) type preparation.* A typical Z preparation is presented in Table 1.  $\text{Na}_2\text{WO}_4 \cdot 2\text{H}_2\text{O}$  was dissolved in deionized water (70 g/l) and the solution was cooled to 5 °C. 1N hydrochloric acid solution (18 % in excess of equimolar reaction) cooled to the same temperature was added to the solution in several doses. The mixture was stirred (120 rpm, blade:  $52 \times 30 \text{ mm}^2$ ) for 1.5 hr in an ice bath and for 0.5 hr at room temperature. The precipitate was separated by centrifuging (5000 rpm). Washing of the precipitate was carried out by addition of water to the precipitate at room temperature followed by stirring and keeping the solid particles dispersed in the liquid. At the end of a washing step the mixture was centrifuged. Several washing steps were applied. After each washing step samples from the centrifuge were dried in exsiccator at room temperature and passed for investigations. The washing conditions were varied by the variation of the volume of the washing liquid, the stirring time and the duration of the washing steps, the effective time while the precipitate was contacted with the washing liquid. After each washing step samples with their mother liquids were collected to ageing analysis. In the case of Z preparations duration of one and two month was chosen for ageing observations. Properly cleaned polythene, or Teflon laboratory vessels and tools, deionized water ( $2 \mu\text{Scm}^{-1}$ ) and analytical grade reagents were used for the experiments.

*Freedman (F) type preparation.* Tungstic acid hydrate samples were prepared following the preparation route of Freedman [12] for comparison (Table 1). Washing of these precipitates was carried out by 0.1N HCl solution on filter. Stirring and centrifuging were

not used for the preparation of these samples. For long-term ageing investigations the tungsten oxide hydrate gels were mixed with water or alkali tungstate solutions and allowed to stay under solutions in polypropylene containers. The following alkali tungstates were deliberately added to solutions: potassium tungstate ( $\text{K}_2\text{WO}_4 \cdot 2\text{H}_2\text{O}$ ), sodium tungstate ( $\text{Na}_2\text{WO}_4 \cdot 2\text{H}_2\text{O}$ ), lithium tungstate ( $\text{Li}_2\text{WO}_4$ ) and ammonium metatungstate ( $(\text{NH}_4)_6\text{H}_2\text{W}_{12}\text{O}_{40} \cdot 2 \cdot 6\text{H}_2\text{O}$ , with  $\text{WO}_3$  %: 91.3%,  $\text{NH}_3$  %: 3.35 %). The suspensions in containers were regularly re-mixed by hand shaking. Four months and 24 months ageing times were chosen for the F suspensions at room temperature.

*Characterization of samples.* The pH values of the washing liquids were also determined. The procedures of the sodium analysis have been described earlier [16]. X-ray powder patterns were recorded at room temperature in a Guinier focusing camera using  $\text{CuK}\alpha$  radiation ( $\lambda = 0.154051 \text{ nm}$ ). Infrared absorption spectra were taken by BOMEM MB-102 FT-IR spectrophotometer equipped with DTGS detector, at a resolution of  $4 \text{ cm}^{-1}$ , in the range of  $400\text{-}4000 \text{ cm}^{-1}$ ; 2 mg/g KBr pellets were used. The morphology of the solid products was studied by scanning electron microscopy with a JEOL-25 microscope. Samples of the strongly adhering powder for SEM have been prepared by controlled dispersing of the powder in deionized water [13]. Droplets of the mixture were poured on conductive specimens and after drying covered with a layer of sputtered gold.

## 3. Results and discussion

Evolution of morphology of Z type particles during ageing process is presented in Fig. 1. Spindle shaped morphology of  $\text{H}_2\text{WO}_4 \cdot \text{H}_2\text{O}$  particles (Fig. 1a) do not represent the final stage of morphology conversion. On longer interaction with liquid (long term ageing at room temperature) fine microsteps develop around the edges of the spindle shaped particles which finally transform

Table 1  
Summary of the preparation conditions for typical Z and F type grains. The concentration of Na is determined by atomic absorption spectroscopy, crystallographic structure by Guinier patterns and FTIR measurements [13]; drying: in exsiccator at room temperature.

Sample	Precipitation conditions			Washing conditions			Product of preparation		
	Quantity of starting $\text{Na}_2\text{WO}_4 \cdot 2\text{H}_2\text{O}$ [g]	Temperature of precipitation [°C]	Number of washing steps	Volume of washing liquid [ml]	Stirring	Centrifuging, 5000 rpm	Time of interaction in one step [h]	XRD Guinier	[Na] in solid [ppm]
Z	10.5	5	5	600	mechanical, 120 rpm, 15 min	3 min	~ 1	$\text{H}_2\text{WO}_4 \cdot \text{H}_2\text{O}$	200
F	16.5	25	3 by 0.1N HCl on filter	2000	none	None	0.12	$\text{H}_2\text{WO}_4 \cdot \text{H}_2\text{O}$	< 10

Samples Z were prepared similarly to the method reported by Zocher [14]; Sample F1 was prepared following the method of Freedman [12]

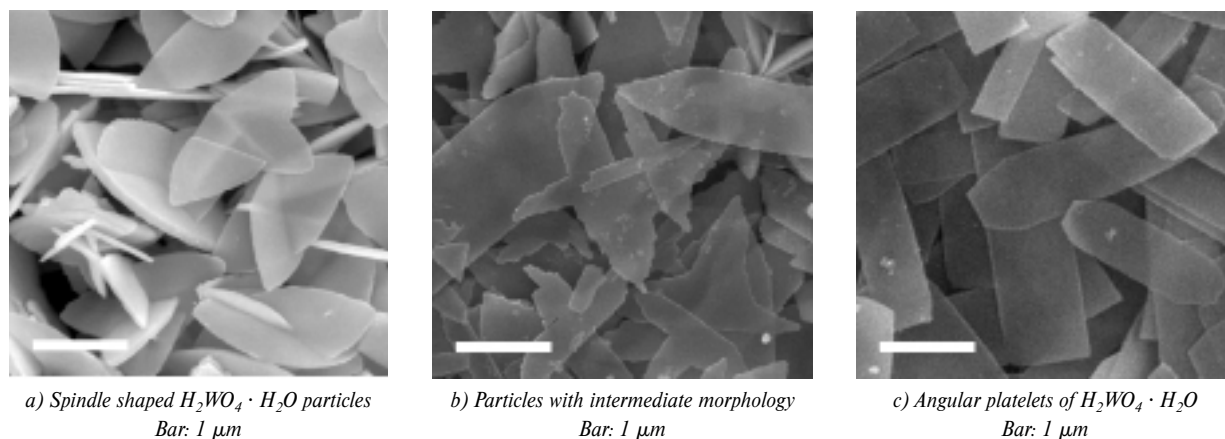

Fig. 1

into angular platelets as it was earlier observed [23] and studied by us in details [3,13]. Particles of  $H_2WO_4 \cdot H_2O$  with deteriorated spindles and intermediate morphology are shown in Fig. 1b. In Fig. 1c well-developed angular platelets represent the final morphology of  $H_2WO_4 \cdot H_2O$  observed after one month in aqueous ambient at room temperature. In earlier reports [3, 11] the pH values were identified, which accurately have described the ranges for morphological changes of Z, type particles. Shape conversions occurred in a pH band from 2.9 to 3.6 during one month ageing, and an enlarging tendency for pH band was observed from 2.8 to 4.9 in the case of two month ageing process [11].

Details about F type particles ageing characteristics can be followed in Table 2. Adhered irregularly shaped submicron grains of freshly prepared F preparation are shown in Fig. 2a. Similar to Z type particles well developed rectangular platelets can be observed after two month ageing in alkali ion free aqueous ambient (Fig. 2b). After 4 and 24 months of ageing on infrared spectra of the un-doped sample a structural conversion, dehydration of  $H_2WO_4 \cdot H_2O$  to  $WO_3 \cdot H_2O$  can be followed (Fig. 3). Room temperature

FTIR absorption bands assignments of the ageing products are presented in Table 3. At ageing of the grains in ammonium tungstate solution the transformation of the grains into new phase(s) are shown in Fig. 2d. After 4-month contact at room temperature between tungsten oxide hydrate grains and  $NH_4^+$  solution a peak at  $1400\text{ cm}^{-1}$  has appeared (Fig. 4b). This peak can be observed after 24 months contact at the same concentration as well (Fig. 4c). A change (breaking of bonds) in  $W = O$  and  $W - O - W$  bonds at lower vibrations than  $1200\text{ cm}^{-1}$  can also be noticed (Table 3.) Moreover, in the case of sample with higher concentration (Fig. 4d) even after 4 months aging one can observe a strong peak at  $1400\text{ cm}^{-1}$ . In this case the vibration changes below  $1200\text{ cm}^{-1}$  -presenting degradation of material- are more clearly shown. We found the peak at  $1400\text{ cm}^{-1}$  evolved in the case of  $S_1/[Li^+]$  sample as well, but with lower intensity than presented in the  $NH_4^+$  case. In solutions with  $Na^+$  and  $K^+$  only a small peak is developing at  $1400\text{ cm}^{-1}$  and the degradation of crystalline phase is more pronounced. According to reference [17], we assign this peak at  $1400\text{ cm}^{-1}$  with modes of adsorbed  $OH^-$ , the pair of this vibration being overlapped with stronger vibrations of struc-

Summary of ageing conditions for F type particles. Samples  $S_1/[Li^+]$  and  $S_1/[Na^+]$  dissolved in the alkali tungstate solutions after a few days.

Table 2

Sample	$H_2WO_4 \cdot H_2O$ g	Added alkali tungstate solution		pH immediately after mixing	pH after 2 months
		Volume ml	Concentration of alkali ion, N		
$S_{undoped}$	0.72	76		2.34	2.23
$S_1/[NH_4^+]$	0.72	50	0.095	2.49	2.59
$S_2/[NH_4^+]$	0.72	28	0.017	2.12	2.00
$S_1/[K^+]$	0.72	50	0.095	6.88	6.28
$S_2/[K^+]$	0.72	30	0.016	3.61	3.92
$S_1/[Na^+]$	0.72	50	0.097	6.42	6.22
$S_2/[Na^+]$	0.72	30	0.016	3.61	4.42
$S_1/[Li^+]$	0.72	50	0.095	5.96	6.33
$S_2/[Li^+]$	0.72	30	0.016	3.31	5.06

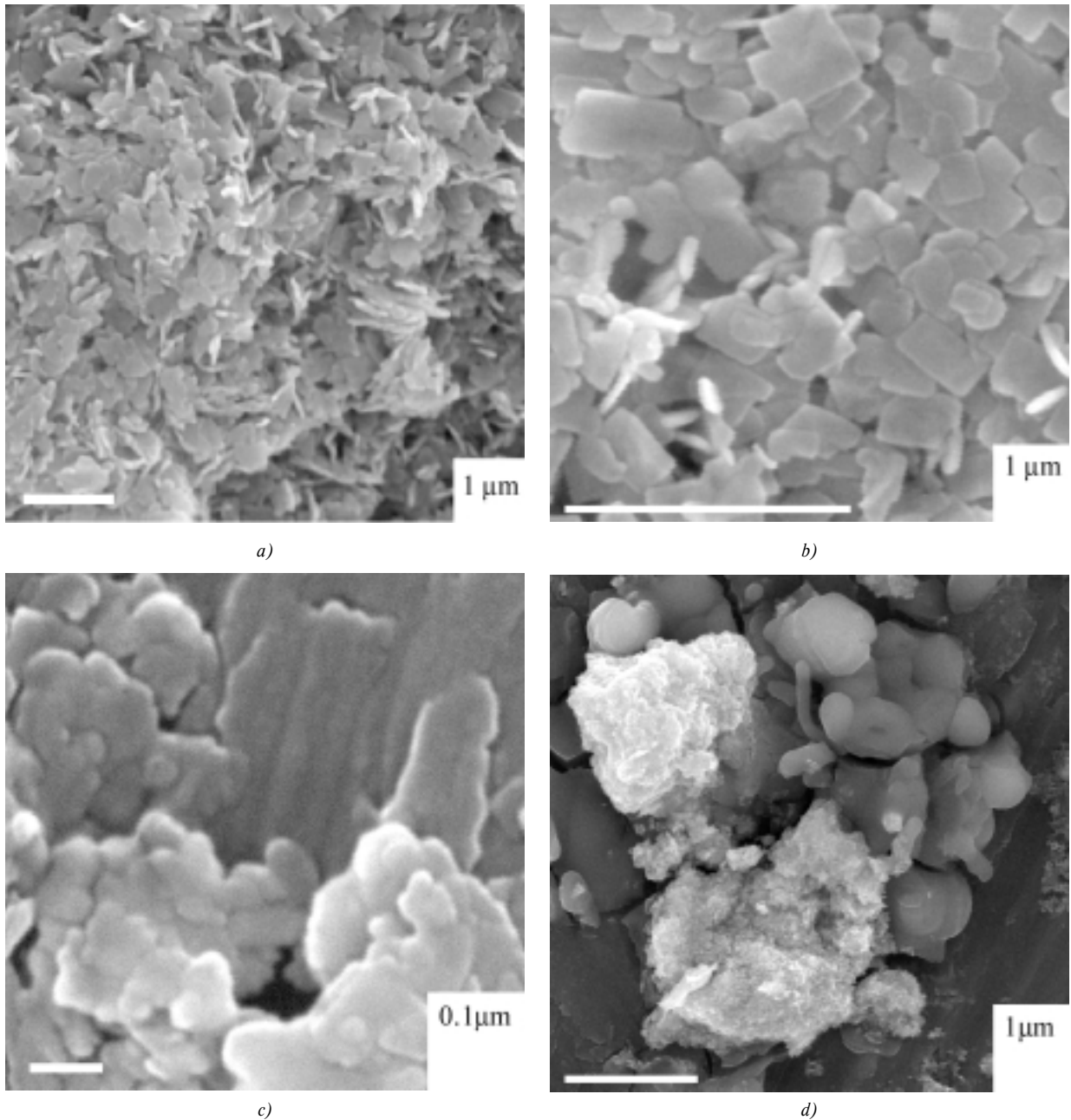

Fig. 2.

tural water in our case (in the range of  $3000\text{-}3600\text{ cm}^{-1}$ ). On the basis of IR spectroscopic measurements we consider that this peak is an indicator for the presence of alkali ions in solution. In this regard is interesting to recall some of the discussions about several ion insertion studies [8,18,19]. J-G. Zhang et al. [18] considered the following ion-exchange reaction at  $\text{Li}^+$  insertion in  $\text{WO}_3$  films, for small  $x$  values in  $\text{Li}_x\text{WO}_3$ :  $(\text{W} - \text{OH}) + \text{Li}^+ \rightarrow (\text{W} - \text{OLi}^+) + \text{H}^+$ . They found a diffusion coefficient for  $\text{Li}^+$  higher in the presence of humidity than in dry environment. In agreement with our observations, their IR measurements also showed

a peak at  $1400\text{ cm}^{-1}$ , but discussions about it were not given. Papaefthimiou et al. constructed an efficient electrochromic (EC) device with significant contamination of  $\text{H}_2\text{O}$  and  $\text{OH}^-$  shown in their IR and XPS (X-ray photoelectron spectroscopy) measurements. They note that diffusion coefficient is high in presence of  $\text{OH}^-$  radicals during  $\text{Li}^+$  intercalation process. The irreversibility of this process however (when most of the exchangeable  $\text{OH}^-$  radicals are exhausted) may lead to degradation of EC device. Not surprisingly, we found in ageing products the  $1400\text{ cm}^{-1}$  peak well developed in the case of  $\text{Li}^+$  which has the smallest ionic radius,

Room temperature FTIR absorption bands assignments of the ageing products, drying: in exsiccator at room temperature.

Table 3

Assignations Sample	$\nu$ HOH (H <sub>2</sub> O)	$\delta$ HOH (H <sub>2</sub> O)	$\nu$ W = O	$\nu$ O-W-O	$\delta$ O-W-O	W-OH (W-OHNH <sub>4</sub> )	Reference
S <sub>undoped</sub> 4 month ageing	3536 3374 3177	1605	1005 940 910	682 630	425 377		
S <sub>undoped</sub> 24 month ageing	3424	1626	945	665	-		[17]
S <sub>1</sub> /[NH <sub>4</sub> <sup>+</sup> ] 4 months ageing	3549 3409 3195	1630	1010 947 922 918	785 721 671	(426)	<b>1406</b>	[17, 20, 21]
S <sub>2</sub> /[NH <sub>4</sub> <sup>+</sup> ] 4 months ageing	3549 3407 3204	1630	1009 947 926	719 659	466	<b>1410</b>	[17, 20, 21]
S <sub>2</sub> /[NH <sub>4</sub> <sup>+</sup> ] 24 months ageing	3557 3434 3208	1636	1010 954 951	681	(466)	1410	[17,20,21]

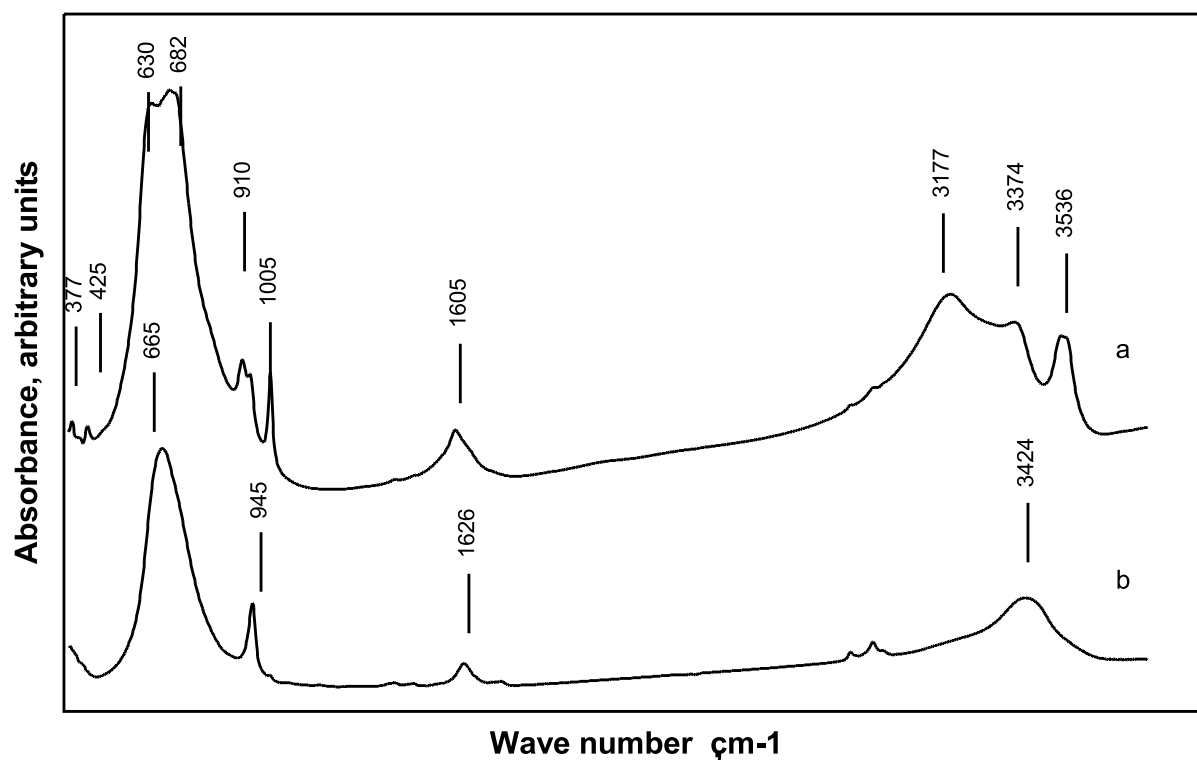

Fig. 3.

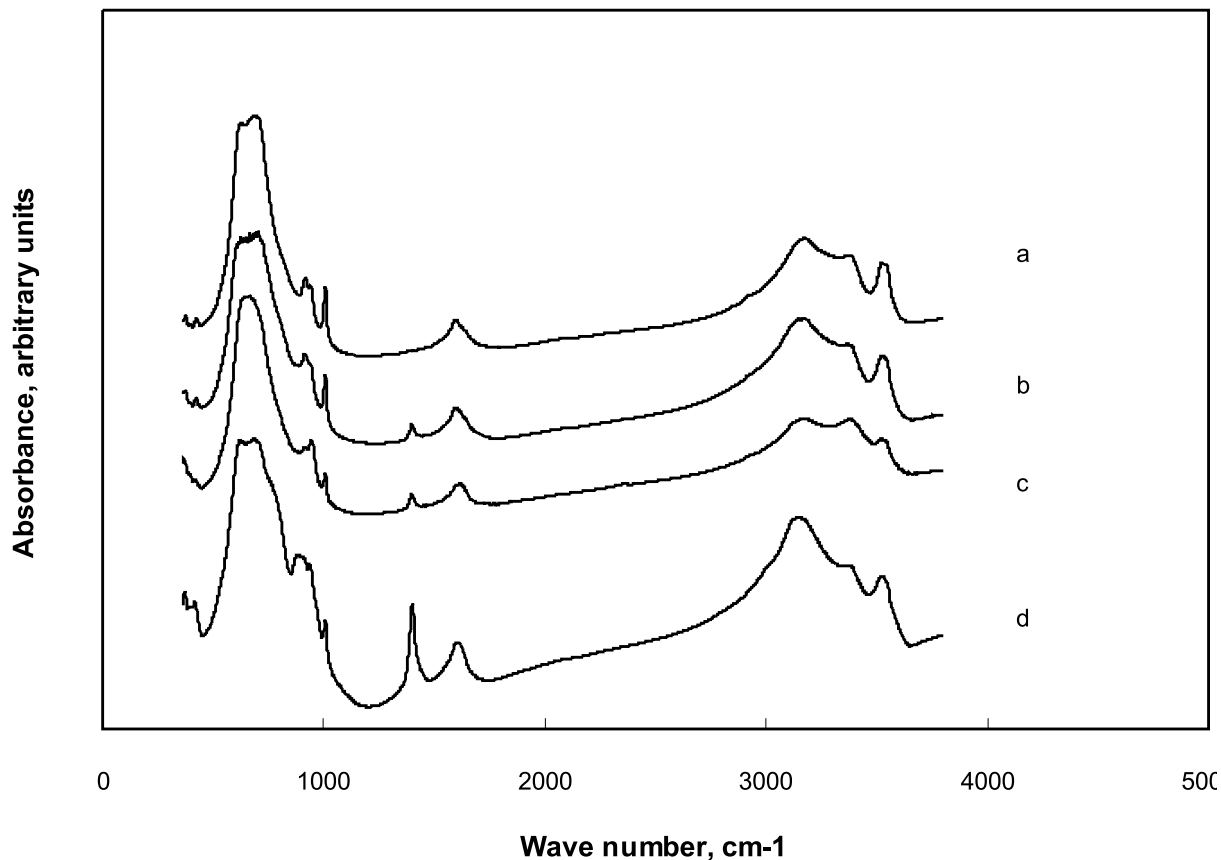

Fig. 4.

60(+1) pm. In the case of  $\text{NH}_4^+$  that has ionic radius larger than  $\text{Na}^+ - 95(+1)$  pm and  $\text{K}^+ - 133(+1)$  pm we should consider the role of large amount of proton species chemically present on neighboring places close to tungsten-oxygen octahedral units ( $\text{WO}_6$ ). In our opinion this fact could explain the increasing peak intensity with increasing ion concentration (Fig. 4). Judeinstein and Livage [24] have recently measured a lithium diffusion coefficient 10-100 times greater for  $\text{WO}_3$  monohydrate than for anhydrous  $\text{WO}_3$ . The authors assumed that water molecules were strongly involved in the ionic conduction mechanism (e.g.  $\text{Li}^+$  ions in  $\text{WO}_3 \cdot \text{H}_2\text{O}$  remain close to the water molecules in the interfoliar space, whereas the whole oxide is affected in the anhydrous oxide). Cheng et al. and Gui et al. have published IR data for ammonium tungstate compounds  $(\text{NH}_4\text{OH})_x \cdot \text{WO}_3$  ( $0.13 < x < 0.33$ ) and  $(\text{NH}_4)_{0.25}\text{WO}_3 \cdot 1/3\text{H}_2\text{O}$  revealing a well-developed peak at  $1400 \text{ cm}^{-1}$ . Summarizing the presented literature data and our FTIR results it can be concluded that ageing at room temperature in alkali solutions resulted in incorporation of alkali ions into the tungstate structure,  $\text{NH}_4^+$  represents the most relevant case in our examinations.

#### 4. Conclusions

Zocher and Freedman type acidic precipitation of tungsten oxide hydrate grains have been performed. Considerable differences have been found between Z and F type preparations. High morphological and structural stability of F type grains can be altered by the presence of alkali ions in solution. The grains develop into a more regular shape in un-doped low pH ambient. In the presence of cations the preservation of the grain shape, the intergrowth of grains and the full recrystallization depend on the chemical character (and concentration) of the cation. On long-term observations a peak at  $1400 \text{ cm}^{-1}$  is developing on IR spectra. Compared with literature this peak should be assigned with  $\text{W} - \text{OH}$  vibration, but taking into consideration the insertion processes more likely with  $\text{W} - (\text{OHNH}_4)$  vibration. The important role of  $\text{OH}^-$  radicals should be underlined.

*The study was performed within a research program supported by the Hungarian National Research Fund (OTKA, grants no. T 032730) and János Bolyai Research Foundation.*

#### 5. References

- [1] SHUBERT, W. D.: *Refractory Metals Hard Mat.*, 11 (1992) 151.
- [2] FIGLARZ, M.: *Prog. Solid State Chem.* 19 (1989) 1.

- [3] BALÁZSI, Cs.: *Materials Structure*, Bull. Czech-Slovak Cryst. Ass. Vol. 6, Nr. 2 (1999) 135.
- [4] BALÁZSI, Cs., FARKAS-JAHNKE, M., KOTSIS, I., PETRÁS, L., PFEIFER, J.: *Solid State Ionics* 141-142 (2001) 411-416.
- [5] LEVI, Y., MILLO, O., SHARONI, A., TSABBA, Y., LEITUS, G., REICH, S.: *Europhys. Lett.*, 51 (5), (2000) 564-570.
- [6] GRANQUIST, C. G.: *Handbook of Inorganic Electrochromic Materials*, Elsevier, 1995.
- [7] LAMPERT, C. M.: *Sol. Energy Mater. Sol. Cells.* 52 (1998) 207.
- [8] PAPAETHIMIOU, S., LEFTHERIOTIS, G., YIANOULIS, P.: *Solid State Ionics* 139 (2001) 135-144.
- [9] DELICHERE, P., FALARAS, P., FROMENT, M., GOFF, A. H-L.: *Thin Solid Films* 161 (1988) 35-46.
- [10] LAMPERT, C. M.: *Sol. Energy Mater. Sol. Cells.* 6 (1999) 449.
- [11] BALÁZSI, Cs., PFEIFER, J., TÓTH, A. L., MIHÁLY, J.: *Proceedings Transcom '99*, S6, 59-62.
- [12] FREEDMAN, M. L.: *J. Amer. Chem. Soc.* 81, 3834 (1959)
- [13] BALÁZSI, Cs., PFEIFER, J.: *Solid State Ionics* 124 (1999) 73-81.
- [14] ZOCHER, H., JACOBSON, K.: *Kolloidchem. Beih.* 28, (6), 167 (1929)
- [15] GERAND, B., NOWOGROCKI, G., FIGLARZ, M.: *J. Solid State Chem.*, 38, 312-320, (1981)
- [16] PFEIFER, J., GUIFANG, C., BUXBAUM, P. T., KISS, B. A., FARKAS-JAHNKE, M., VADASDI, K.: *J. Solid State Chem.* 119, 90-97 (1995)
- [17] DANIEL, M. F., DESBAT, B., LASSEGUES, J. C., GERAND, B., FIGLARZ, M.: *J. Solid State Chem.* 67, 235-247 (1987)
- [18] ZHANG, J. G., TRACY, C. E., BENSON, D. K., DEB, S. K.: *J. Mater. Res.*, Vol. 8, No. 10. (1993)
- [19] DINI, D., DECKER, F.: *Electrochimica Acta*, Vol. 43, Nos 19-20, (1998) 2919-2923.
- [20] CHENG, K. H., JACOBSON, A. J., WHITTINGHAM, M. S.: *Solid State Ionics*, 5 (1981) 355-358.
- [21] GUI, C., SHANG-CI, Y., JUAN, Z.: *J. Cent. South Univ. Technol.*, Vol. 31, 6 (2000) 502-505.
- [22] MARCEL, C., TARASCON, J. M.: *Solid State Ionics*, 143 (2001) 89-101.
- [23] FURUSAWA, K., HACHISU, S.: *Sci. Light* (Tokyo), 15 (1966) 115. I and II.
- [24] JUDENSTEIN, P., LIVAGE, J.: *J. Chim. Phys.* 90 (1993) 1137.

Jana Václavková – Ľudovít Kupča \*

## APLIKÁCIA SKÚŠKY TYPU SMALL PUNCH TEST PRI HODNOTENÍ DEGRADÁCIE VLASTNOSTÍ MATERIÁLOV TLAKOVEJ NÁDOBY REAKTORA

### A SMALL PUNCH TEST METHOD APPLICATION FOR THE EVALUATION OF REACTOR PRESSURE VESSEL MATERIAL PROPERTIES DEGRADATION

*Príspevok popisuje stanovovanie základných mechanických vlastností materiálov tlakovej nádoby reaktora (TNR) pomocou skúšky typu „small punch test“. Najväčšou výhodou skúšok tohto typu sú malé rozmery vzoriek, a teda nízka spotreba často originálneho skúšobného materiálu.*

*Použitím skúšky small punch test môžeme stanoviť nasledovné hodnoty základných mechanických vlastností:*

- medza klzu a medza pevnosti v ťahu,
- prechodová teplota vrubovej húževnatosti,
- lomová húževnatosť.

*Táto metódika skúšania je súčasťou Nového programu overovacích vzoriek, koordinovaného VÚJE Trnava, a. s. Program sa zaoberá hodnotením vlastností materiálov TNR jadrovej elektrárne staršieho typu V-1 v Jaslovských Bohuniciach. V príspevku je popísaná metódika vyhodnocovania výsledkov, metalografická príprava malých vzoriek, a aj porovnanie výsledkov skúšky small punch test s výsledkami štandardných skúšok mechanických vlastností.*

*In this paper we describe a new non-standard method for estimation of the reactor pressure vessel (RPV) materials mechanical properties by a small punch (SP) test. The great advantage of the SP test method is a low volume of test samples.*

*Using this method it is possible to obtain the following data of basic mechanical properties:*

- the yield stress and ultimate tensile strength,
- ductile-brittle transition temperature,
- the fracture toughness value.

*This method has been involved in the VÚJE project “New Surveillance Specimen Program for Jaslovské Bohunice V-1 nuclear power plant (NPP)” (NSSP). This paper describes the basic information about a testing procedure, metallographic preparation of test samples and comparison between results from standard tests and this new testing method.*

#### 1. Introduction

Presently, there has been a number of investigations on the evaluation of mechanical properties of various alloys using the small punch test method [1-3, 6].

Small punch testing methods are very popular now due to the:

- low consumption of the original testing material,
- relatively simple evaluation,
- possibility of using universal and cheap testing machines,
- uniformity of specimen for the several type of testing procedures.

However, the details of the method employed by individual research teams have differed somewhat from one to the other according to:

- specimen size and shape,

- punching tool (ball or rod),
- configuration of testing holder,
- number of specimen for one type of material, etc.

Most of research teams used this method for mechanical properties of metallic materials evaluation, but relatively few investigations have dealt with irradiated specimen [6].

Various standard tests are available for the determination of mechanical properties such as tensile strength, ductile-brittle transition temperature and fracture toughness, which are required for the structural integrity assessment of NPP components. In order to study irradiation damage, small samples are required because there are limitations on a sample size in irradiated material testing evaluation. SP samples have a great advantage in reducing the radioactivity of the irradiated materials for their small volume.

\* Ing. Jana Václavková, doc. Ing. Ľudovít Kupča, CSc.

VÚJE Trnava Comp., Okružná 5, 918 64, Trnava, Slovak Republic, Tel.: ++421-805-5991564, 5991560, Fax: ++421-805-5991502,

E-mail: vaclavkova@vuje.sk, kupca@vuje.sk

The SP procedure has also advantage for the determination of material properties, which are highly dependent on the local microstructure (e.g. heat affected zone).

## 2. Basic information on a small punch test method

### 2.1 Outline of the test

Figure 1 shows the set up for the small punch test. The principle of our testing procedure is penetration of the disk sample by hemispheric rod [5]. Disk shaped sample has 8 mm in diameter and 0.5 mm in thickness (Figure 2). The specimen holder consists of a lower and upper die and holder body. Using this specimen holder, the specimens are prevented from cupping upward during punching and therefore, the plastic deformation is concentrated in the region below the punch rod. Using a relatively simple system with recorders of the load and deflection values, we can obtain the following data of basic mechanical properties:

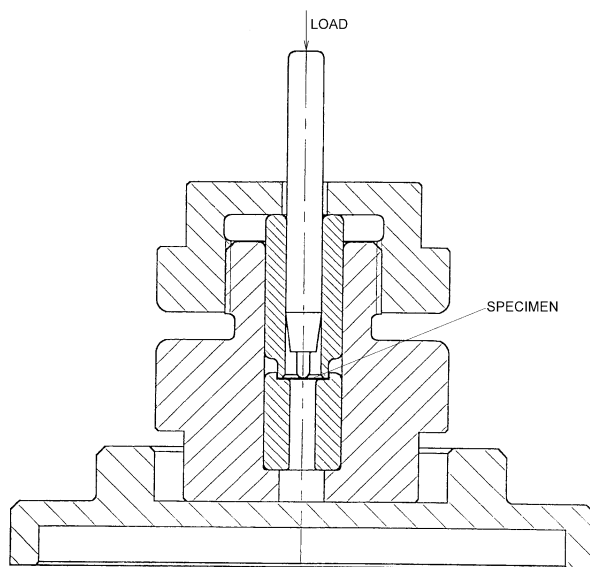

Fig. 1. The set up for the SP test procedure

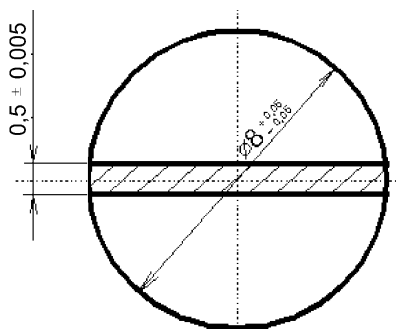

Fig. 2. The SP sample dimensions

- The yield stress and ultimate tensile strength at room temperature, which are correlated well with the parameters  $P_y$  and  $P_{max}$ , respectively.  $P_y$  and  $P_{max}$  are the loads corresponding to the yield and maximum strength of testing material.
- Ductile-brittle transition temperature (DBTT) measured by a Charpy test can be predicted from the results of temperature dependence of small punch energy (SP energy) determined from the area under the load - deflection curve.
- Fracture toughness  $J_{IC}$  can be evaluated using equivalent fracture strain  $\bar{\epsilon}_{gf}$ .

### 2.2 Apparatus

The testing is performed on a universal test machine INOVA TSM 10, equipped with load recorder, crosshead speed recorder, and data recorder for registration of load-deflection curves. Special fixture is used for the fixing of specimen and realization of SP test. For the low-temperature test, special temperature chamber cooled with liquid nitrogen vapor or liquid nitrogen is used[8].

### 2.3 Evaluation method of the base mechanical properties

#### 2.3.1 Tensile properties

A typical load-deflection curve is shown in the figure 3. The loading force  $P$  at initial localized plastic strain is  $P_y$  and load maximum,  $P_{max}$ , can be related to the yield strength and the ultimate tensile strength, respectively. The empirical linear relationships can be expressed by equation:

$$\sigma_{y, \max} = kP_{y, \max} + q \quad (1)$$

where  $k$ ,  $q$  are constants obtained from comparing small punch results and results from the standard tensile test on the reference material.

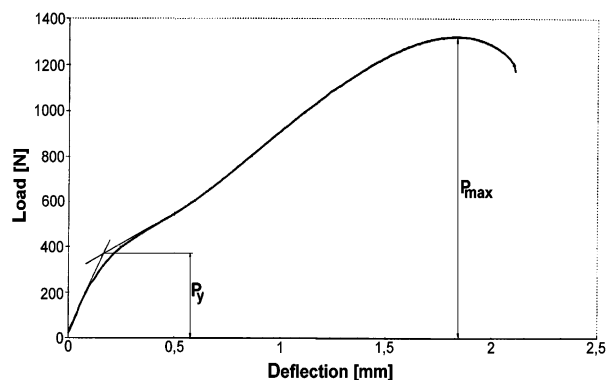

Fig. 3. Typical load-deflection SP curve for 15Ch2MFA material

### 2.3.2 SP Energy and SP ductile-brittle transition temperature (SPDBTT)

SP energy is estimated from the area under the load-deflection curve up to the fracture load or maximum deflection. Numerical integration method is used for the estimation. SPDBTT is defined by temperature at the energy level

$$SPDBTT = (SP_{max} + SP_{min})/2 \quad (2)$$

where  $SP_{max}$  and  $SP_{min}$  are energies at the upper and lower shelves, respectively. SP energy was analytically related with the ductile-brittle transition behavior by several authors. SPDBTT is approximately linear correlated with DBTT measured by a Charpy test using formula:

$$TT_{SP} = \alpha \cdot DBTT \quad (3)$$

where  $\alpha$  is correlation coefficient [6].

### 2.3.3 Fracture toughness

According to Mao et al. [3]  $\delta^*/t_0$  is related to the equivalent fracture strain  $\bar{\epsilon}_{gf}$  by equation:

$$\bar{\epsilon}_{gf} = \ln(t_0/t^*) = \beta (\delta^*/t_0)^2 \quad (4)$$

where  $t^*$  is the minimum thickness at the fracture portion and  $t_0$  is initial thickness of specimen,  $\beta$  is a constant, and  $\delta^*$  is the maximum deflection at fracture.  $J_{IC}$  can be estimated by a correlation between  $\bar{\epsilon}_{gf}$  and  $J_{IC}$  obtained for testing material.

## 3. Application of the small punch test for NSSP

### 3.1 Materials

The experimental materials were base material, weld metal and heat affected zone of the RPV 15Ch2MFA steel. From this type of material we prepared samples, which have been irradiated in power reactor in Jaslovské Bohunice V-2 NPP unit 3 [4, 9].

### 3.2 Sample preparation

The testing results are extremely dependent on the quality of specimen preparation. Samples are polished by one of the following methods:

- manually polish on the polishing papers for final thickness,
- grinding on the horizontal machine and then manually polish on the papers.

We have tested a new effective polishing method of the SP sample preparation, using the metallographic polishing machine on the special abrasive disks, which is illustrated on the figure 4. Three special holders are used for the fixation of four samples in each holder.



Fig. 4. Metallographic polishing machine with special holders

### 3.3 Testing conditions

Yield strength and ultimate tensile strength are evaluated by ambient temperature. The fixing torque is less than 5 Nm. Crosshead speed was 2 mm/min. For the evaluation of the ductile-brittle temperature, we used special cooling chamber. Testing was performed in the range temperatures from 77 K to ambient temperature. Temperature precision is controlled by system of the three thermocouples. Crosshead speed was higher (3 mm/min) than for tensile testing to achieve the constant temperature during the single test. For the evaluation of the fracture toughness value, we used cross section measurement of the sample after the penetration. Fracture thickness portion and initial thickness of specimen were measured by image analyzer procedures.

### 3.4 Correlations and examples of the initial state RPV materials results for NSSP

Correlations of SP parameters with the tensile properties for the base material and weld metal are described in Ref. [6]. Both SP and standard tests were done at room temperature.  $P_y$  and  $P_{max}$  correlate well with yield strength and ultimate tensile strength, respectively.

Table 1 summarizes the results from SP test for tensile properties estimation.

SP results for estimation of the tensile properties for the 15Ch2MFA steel

Table 1

Material	$P_{max}$ [N]	$P_y$ [N]	$R_m$ [MPa]	$R_e$ [MPa]	$R_m^*$ [MPa]	$R_e^*$ [MPa]
base material	1274	316	657	512	641	525
weld metal	1298	318	602	479	589	467
HAZ	1328	330	685	540	-	-

\* average results from standard tests

Example of the temperature dependence of SP energy for the base metal RPV is shown on the figure 5. In this case, SPDBTT is defined as the temperature corresponding to the middle energy between the energy at the intersection of the two fitting curves and energy at 50 K.

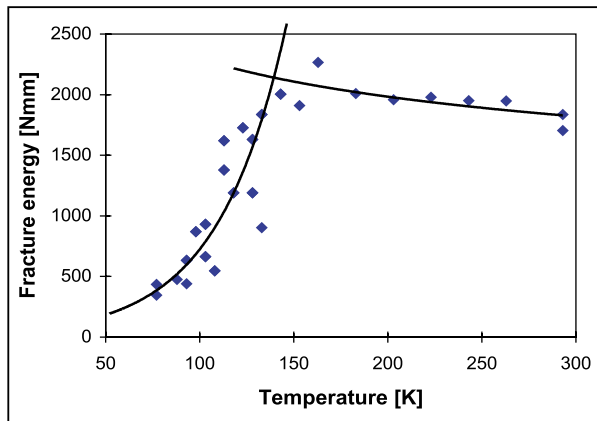

Fig. 5. Temperature dependence of the SP energy for 15Ch2MFA

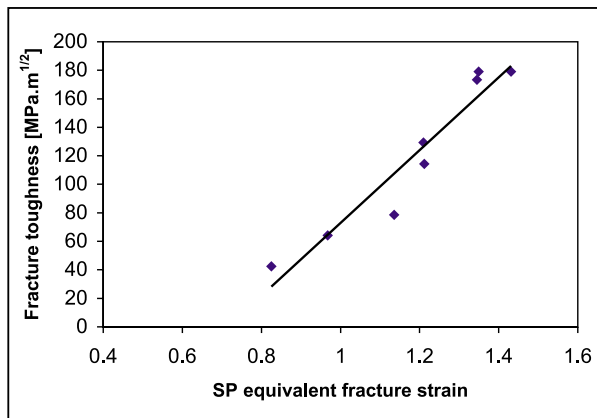

Fig. 6. Correlation between  $J_{IC}$  and  $\bar{E}_{gf}$  for the weld metal RPV

Transition temperatures from standard Charpy-V tests and small punch tests are summarized in the table 2.

## 5. References

- [1] CORWIN, W. R., HAGGAG, F. M., SERVER, W. L., EDS.: *Small Specimen Test Techniques Applied to Nuclear Reactor Vessel Thermal Annealing and Plant Life Extension*, ASTM STP 1204, Philadelphia, 1993
- [2] CORWIN, W. R., ROSINSKI, S. T., E. VAN WALLE, EDS.: *Small Specimen Test Techniques*, ASTM STP 1329, West Conshohocken, 1997
- [3] MAO, X., SHOJI, S., TAKAHASHI, H.: "Charakterization of Fracture Behaviour for Small Punch Test by Combined Recrystallization Eich Method and Rigid Plastic Analysis", *Journal of Testing and Evaluation, JTEVA*, Vol. 15 No.1, 1987, pp.30-37,
- [4] KUPČA, L., PROVAZNÍK, J.: "Preparation of the Experimental Material for NSSP Project Realization", Round Robin Exercise on WWER-440 Weld Metal Irradiation Embrittlement, Annealing and Reembrittlement, Technical Report of VÚJE Trnava a.s. No. 0360/43/99, 30.11.1999
- [5] VÁCLAVKOVÁ, J., KARÁSEK, J.: "Experimental Evaluation of the Reference Curve for Yield Stress and Ultimate Tensile Strength Estimation of the 15Ch2MFA Steel by Small Punch Test", Technical report No. T14/2000 Vitkovice, Jun 2000. (in Slovak)

Transition temperatures for materials from NSSP

Table 2

Material	Charpy-V test			SP test
	$TT_{KCV50}$ [°C]	$TT_{PHL}$ [°C]	$TT_{\Delta B}$ [°C]	$TT_{SP}$ [°C]
BM	-43	-16	-	-15.2
WM	-15.4	-12.9	1.2	-15.5
HAZ	-	-	-	-35.2

Value of  $\bar{E}_{gf}$  was calculated using equations from chapter 2.3 using both formulas. For the weld metal RPV,  $J_{IC}$  obtained from standard test versus  $\bar{E}_{gf}$  calculated from these equations is plotted in figure 6. This curve will be used for evaluation of the  $J_{IC}$  shift after irradiation in the NSSP [3]. Table 3 summarized fracture toughness values measured on ambient temperatures by standard test on the COD samples and by small punch test.

Fracture toughness values measured on ambient temperatures for NSSP materials

Table 3

Material	$J_{IC \text{ standard COD}}$ [MPa.m <sup>-1/2</sup> ]	$J_{IC \text{ SPT}}$ [MPa.m <sup>-1/2</sup> ]
BM	-	369
WM	179	163
HAZ	-	306

## 4. Conclusions

From the experiments follow these main conclusions:

- SP test methods are suitable for basic mechanical parameters like tensile properties, evaluation of DBTT or fracture toughness.
- The great advantage of SP test methods is a low consumption of experimental material and possibility to use this method for irradiation experiments in power reactors.
- Geometry of specimen is convenient for properties evaluation of the heat-affected zone.

Main goal for the future is to standardize SP method for industrial applications.

- [6] VÁCLAVKOVÁ, J., KUPČA, L., BŘEZINA, M.: *Small punch test method application for the estimation of the material properties degradation*, CO-MAT-TECH 2000, Trnava 2000.
- [7] BAIK, J. M., KAMEDA, J., BUCK, O.: "Development of Small Punch Tests for Ductile-Brittle Transition Temperature Measurement of Temper Embrittled Ni-Cr Steels", The Use of Small-Scale Specimen for Testing Irradiated Materials, ASTM STP 888, W.R. Corwin, G.E. Lucas, Eds., American Society for Testing and Materials, Phil., 1986, pp.92-111.
- [8] SOJKA, J., BALON, O., PANNA, J.: "Zařízení pro hodnocení mechanických vlastností malých vzorků pomocí penetračních testů za normální teploty a za snížených teplot" (Popis a návod k obsluze), Vitkovice a.s., Ostrava 1998.
- [9] IAEA: *TC Project RER/9/035 „Round - Robin exercise on WWER-440 RPV weld metal irradiation, embrittlement, annealing and re-embrittlement”*, Vienna, Austria, Nov. 1996.

## RIEŠENIE KRÍZOVÝCH SITUÁCIÍ 2002

Fakulta špeciálneho inžinierstva Žilinskej univerzity v spolupráci s Ministerstvom hospodárstva Slovenskej republiky organizuje v dňoch 22. a 23. mája 2002 *VII. medzinárodnú vedeckú konferenciu Riešenie krízových situácií v špecifickom prostredí*

Konferencia sa bude rokovať na plenárnom zasadnutí a v štyroch sekciami:

- Sekcia č. 1: Krízové riadenie a krízové plánovanie
- Sekcia č. 2: Požiarna ochrana a záchranné služby
- Sekcia č. 3: Bezpečnostný manažment - ochrana osôb a majetku
- Sekcia č. 4: Ľudský činiteľ v krízovom riadení

Konferencia sa uskutoční v priestoroch Žilinskej univerzity.

Všetkých záujemcov srdečne pozývame.

## CRISES SITUATIONS SOLUTION 2002

The Faculty of Special Engineering of the University of Žilina in cooperation with the Ministry of Economy of the Slovak Republic is organizing from 22 to 23 May, 2002 the *Seventh International Scientific Conference devoted to Crises situations solution in specific environment.*

The conference will proceed in plenary session and in these four sections:

- Section No. 1: Crisis management, crisis planning
- Section No. 2: Fire prevention and safeguarding services
- Section No. 3: Security management - people and property protection
- Section No. 4: Human factor in crisis management

The conference will be held at the University of Žilina.

All interested are cordially invited.

### Sekretariát konferencie:

Fakulta špeciálneho inžinierstva Žilinskej univerzity v Žiline

### Secretary of the conference:

The Faculty of Special Engineering of University of Žilina, Slovakia,

Ing. Ladislav Novák, PhD.

Ul. 1. mája 32, B-27, SK-010 26 Žilina, Slovakia, Tel.: ++421-41-7633320, ex. 242, 244, Fax: ++421-41-7234972,  
E-mail: novak@fsi.utc.sk, www.utc.sk/fsi/

Octavian Pop – Tamás Máhr – Tímea Dreilinger – Róbert Szabó \*

# ARCHITEKTÚRA DOJEDNÁVANIA ŠÍRKY PÁSMÁ V SIEŤACH DIFFSERV

## BANDWIDTH BROKER ARCHITECTURE FOR DIFFSERV NETWORKS

*Bandwith Broker (BB) je automatizovaný manažér zdrojov v architektúre diferencovaných služieb. Riadi alokáciu zdrojov podľa požiadaviek na kvalitu služby v rámci jednej alebo následných domén podľa dostupných zdrojov a kontraktu o kvalite služby, ktorý bol dohodnutý medzi zákazníkom a poskytovateľom služby. Ak je použité multidoménové riadenie zdrojov, systémy dojednávania šírky pásma vyjednávajú navzájom v mene iniciátora služby. Navyše sa tieto systémy tiež zúčastňujú v komunikácii tranzitných domén koordinovaním dohôd o kvalite služby poskytovanej na rozhraní medzi doménami. Boli navrhnuté rôzne architektúry BB a niektoré z nich boli dokonca aj implementované. Všetky sú ale len v predbežnom štádiu alebo neriešia podstatné problémy, ako napr. obojsmerná alokácia zdrojov. V tomto článku navrhujeme BB architektúru, ktorá má funkcie riadenia pre autorizáciu, podporuje kvantitatívne a kvalitatívne služby, dojednáva obojsmernú alokáciu zdrojov a podporuje riadenie zdrojov, ktoré je nezávislé od výrobcu, t. j. nevyžaduje žiadne úpravy softvéru alebo hardvéru v chrbticových smerovačoch.*

*A Bandwidth Broker (BB) is an automated resource manager in the Differentiated Services architecture. It manages Quality of Service resource allocation requests within a single or successive DiffServ domains based on the available resources and on the Service Level Agreements formerly negotiated between the customer and its service provider. If used for multi-domain resource management, BBs negotiate among each other on behalf of the service initiator. Additionally, BBs also participate in transit domain communication by coordinating SLAs across domain boundaries. Various BB architectures have been proposed in the recent years, some of them even have been implemented, but all of them are in a preliminary stage or do not address important issues such as bi-directional resource allocation. In this paper we propose a BB architecture that includes policy manager functions for authorization, supports quantitative and qualitative services, handles bi-directional resource allocation and features a vendor-independent resource allocation approach, i.e., neither software nor hardware modification of core routers are required.*

### 1. Introduction

Internet quality of service insurance has attracted substantial interest in recent years, because the best-effort service quality currently offered by the Internet does not meet requirements of real-time applications appearing on the market. Therefore, service providers are finding it necessary to offer their customers various levels of service. Continuing research has yielded two approaches for providing *Quality of Service (QoS)*. The *Integrated Services (IntServ)* architecture [2] differentiates services on a per-flow basis. The *Differentiated Services (DiffServ)* [1] [3] architecture, on the other hand, divides the network into domains with their own resources and aggregates traffic flows into classes to avoid the scalability problem of IntServ caused by the per-flow differentiation.

In this architecture QoS enforcement is basically realized by two entities [1]: *core routers* that are located internally in a DS domain without any interface to the outside world, and *edge*

*routers* that connect one DS domain to a node in another DS domain or in a domain that is not DS capable. According to the former separation core routers only handle IP packets according to their pre-assigned service classes attempting to provide the required quality. On the other hand, edge routers realize the storing of flow related information and most of the complicated functions e.g. policy control and flow classification.

In the DS architecture two service models are distinguished, where the *service* is the overall treatment of a defined subset of a customer's traffic within a DS domain or end-to-end. In the *absolute service*, the user is assured of the requested performance level at the expense of strict admission control functions. Accordingly, requests are rejected if there is not enough available resource to accommodate the new service without violating the quality of already existing services. With *relative services*, users are only assured of relative differentiation; which can be provided without explicit admission control function by some active queue management algorithms or packet schedulers.

\* Octavian Pop, Tamás Máhr, Tímea Dreilinger, Róbert Szabó

High Speed Networks Laboratory, Department of Telecommunications and Telematics, Budapest University of Technology and Economics, H-1117, Pázmány Péter sétány 1/D., Budapest, Hungary, Tel.: +36-1-463 2187 Fax: +36-1-463 1763, E-mail: [pop, mahr, dreiling, szabor]@ttt-atm.ttt.bme.hu

The *Internet Engineering Task Force* (IETF) has also developed RFCs that not only describe the above mentioned DiffServ functional architecture, but standardize some externally observable forwarding attributes called *Per-Hop-Behavior* (PHBs) of a DiffServ-compliant node.

Efficient use of absolute services implies signaling: customers should be able to signal their demands to the service provider. There is an obvious need for on-demand call admission control mechanisms to admit connection requests to the network based on available resources in the network. Following a positive acknowledgement edge routers must be configured accordingly. A policy manager should further authenticate and check the authorizations of each service requester based on the SLAs. *SLA (Service Level Agreement)* [1] is a service contract between a customer and a service provider that specifies the service customer should receive, where the customer may be a user organization or another DS domain. Flows traversing multiple DiffServ domains can only be served by enabling communication among successive *Internet Service Providers* (ISPs). All of these functions can be achieved by entrusting the resources of each DiffServ domain to a centralized manager agent called a *Bandwidth Broker* (BB) [6].

Figure 1 shows a sample network scenario [4]. Roughly, if user A wants to reserve resources for sending data to user B, he will send a request to the BB1. BB1 checks the SLA of user A (*policy server function*) and if authentication and permissions are adequate BB must check resource availability in its domain (*call admission control*). Since the reservation is initiated for multiple domains in our case, there is a need for communication between BB1 and BB2 (*inter-domain communication*). Note that BB2 also has to make the call admission control for its own domain to establish end-to-end reservation. Finally, the BB1 configures the edge routers to classify the user A data into the appropriate class.

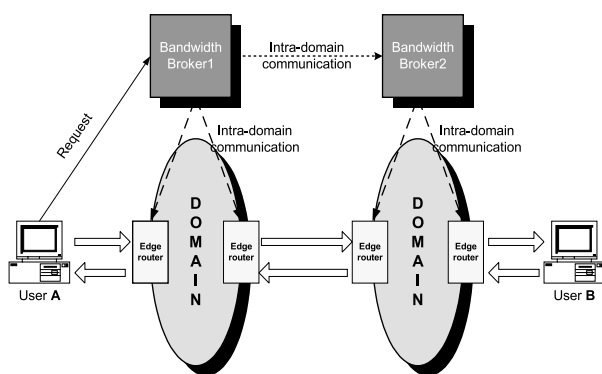

Fig. 1. Bandwidth Broker in a DiffServ domain

Our goal was to design and implement a Bandwidth Broker architecture for a Linux-based DiffServ test bed. We designed and added to our BB a resource reservation scheme that requires neither software nor hardware upgrades in core routers. There already exists a similar idea independently developed and presented in [7], however the method to determine the reservation path for flows was not sufficiently elaborated or presented. There-

fore, we created and implemented a lightweight route discovery technique that is independent from the underlying routing protocol and the domain topology. Our proposal also handles path changing in a network. Another important issue is the problem of reservations for *destination requested flows (backward reservation)*, i.e., where the service requesting entity acts as a sink for a QoS flow while the sender is unaware of QoS signaling. Note that most candidate QoS applications require either bi-directional or such a destination requested flow, e.g. Internet telephony or video-on-demand. To the best knowledge of the authors neither the problems of reservation for destination requested flows nor their possible solutions are discussed in the literature. However, in our proposal we address this problem too.

In what follows, section 3 outlines our BB architecture. It covers the supported services and the necessary QoS forwarding mechanisms as well as our proposed resource allocation technique. We present our resource reservation signaling focusing on the proposed path discovery scheme for call admission control and the backward resource reservation method. Section 4 sets forth some implementation issues and finally we conclude the work in section 5.

## 2. The proposed BB Architecture

### 2.1. Supported Services

Our objective was to concentrate on two very typical services, one in the absolute, and one in the relative service group. Our first supported service is a *Virtual Leased Line* (VLL), the second, a relative one, is called *Better than Best Effort* (BBE), which is based on *assured forwarding* per-hop-behavior (AF-PHB) [12]. The VLL service, based on *expedited forwarding* per-hop-behavior (EF-PHB) [13] offers guaranteed bandwidth, delay and jitter characteristic for real-time applications. In contrast, BBE offers only three packet dropping levels that assure a higher-level class always has a lower dropping probability than a lower-level class. Since network resource usage cannot grow unbounded beyond the actual capacity, for VLL service it is necessary to support call admission control. In contrast, BBE requires no additional mechanisms, but the forwarding function, which itself assures the necessary relative service differentiation. BBE is only effective with applications using TCP, because it contains flow and congestion control mechanisms allowing active queue management algorithms to take back transmission rates by dropping packets. This way congestion results an unfair competition for resources between TCP and UDP flows [14]. Applications expected to potentially use VLL service in the future will require resource allocation from and/or to the service requester.

In order to use any of the VLL and BBE services users have to reach an agreement (SLA) with the service provider.

### 2.2. Call Admission Control

*Connection admission control* refers to the process performed by BB of admitting connection to the network based on available

resources in the network. As we mentioned before, VLL requires a strict admission control scheme.

### 2.2.1 Distributed vs. centralized Call Admission Control

Some schemes use *hop-by-hop (distributed) methods*, where the overall decision is the sum of successive decisions performed locally at each node along the path that the flow traverses. Notable example protocols are RSVP (Resource reSerVation Protocol) [8] and Boomerang [9]. This scheme has two major drawbacks. First, this is vendor-dependent and each router has to support the same function to be effectively deployed. Second, timing considerations also need to be addressed: routers knowing of free resources in other routers on a timely basis could result in greater network utilization.

Alternatively, one may *centralize the admission control decision* for an administrative domain. However, this requires the BB to be aware of the flow's path and resource availability along this path. We solved this problem as follows: the BB determines the path in question via a lightweight route discovery method. Since this uses an IP's record route feature (a mandatory part of the protocol), this does not break compatibility with other routing protocols, and does not require modification of hardware/software in routers. This brings up another problem: change in the routing tables of domain routers is harder to handle. One may use an SNMP trap, but this requires the routers and topology maintenance of the domain. We propose to check the routes of active connections periodically instead. This also does not require modification of core router software/hardware.

### 2.2.2. Measurement vs. reservation based admission control

The decision may be based on *measurements*, this is mainly adequate for a centralized scheme. Edge routers may measure some performance metrics in a DiffServ domain and the results may directly determine the acceptance or rejection of new connections. The measurements can also be made on an end-to-end basis by checking the resource availability with probe traffic [10] [11]. The other alternative is to use a *reservation based admission control*, i.e. the used/available resources are tracked and allocation requests are rejected accordingly. We have used this kind of call admission as the VLL service must provide hard guarantees for real-time applications thus one cannot risk the overbooking here.

## 2.3. Resource Reservation Signaling

Resource reservation signaling consists of two sub-parts: route discovery and resource reservation for self-destined flows.

### 2.3.1. Route discovery signaling

We named our proposed route discovery scheme used along the call admission control to *Discover Forwarding Path (DFP)* mech-

anism and works as follows. Customers demand services by passing *Resource Allocation Requests (RAR)* messages to their BBs. The RAR contains the required service type, traffic descriptor (for VLL), destination address, ingress edge router, flow direction and time duration of service reservation. The customer may pass the RAR to the IP address of the BB. In our method, customers send the RAR to their ingress router, which in turn forwards it to the BB of the domain. The RAR of the user can thus omit the ingress edge router address; the edge router itself will add it to the RAR packet (Figure 2, messages #1 and #2). Upon the reception of a new RAR message in the BB, it asks the ingress edge router (message #3) to send a special empty IP packet with the *IP record route* option preset toward the flow's destination. This DFP packet follows the path that the flow will take. All core routers add automatically their used outgoing interface address to the DFP packet (Figure 2 messages #4, #5 and #6). Egress edge routers must capture these DFP packets before leaving the domain to turn it back to the BB (Figure 2, message #7). The BB now knows which router interfaces' utilization have to be checked and accepts/rejects the flow accordingly.

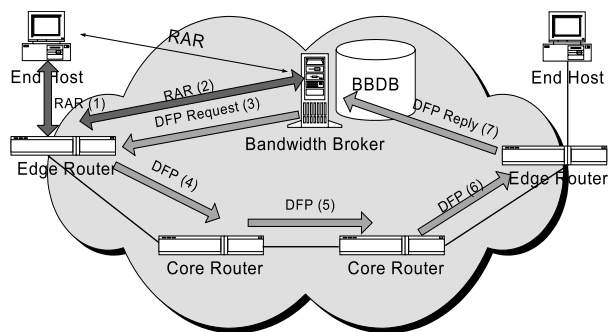

Fig. 2. Route discovery method

## 2.4. Backward resource reservation

We designed resource reservation signaling with resource reservation going from a sender to the service requester (backward direction) in mind. This is not a trivial venture, as initially nothing prevents destination-originated flows (service requester) from having different paths from source-originated flows. Technically, any resource reservation must be started from the source's domain and not from the service requester's. The RAR is then sent to the destination domain's BB, and therein lies our problem: the destination domain's BB does not have global network topology knowledge. Our ICMP-based solution is presented in Figure 3.

The numbers in figure 3 depict the following sequence of events:

1. User sends the RAR to its BB (through ingress edge router) for a flow having the destination the user itself.
2. BB belonging to the user's domain sends this request in a special marked ICMP-ECHO *request* packet to the flow source.
3. The source end-host automatically replies with an ICMP-ECHO *reply* packet

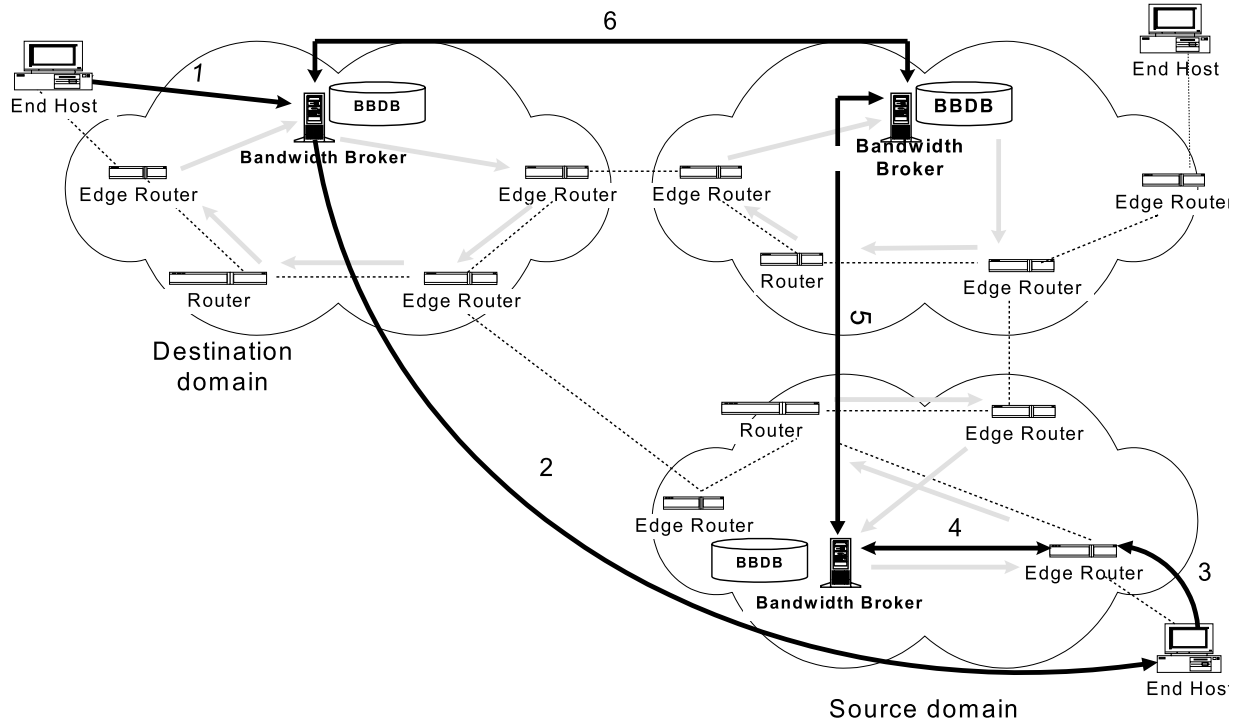

Fig. 3. Backward resource reservation

4. The source's edge router catches this packet, as it is a special marked ICMP-ECHO *reply*. Then, the withdrawn request is sent to the BB of the source domain.
5. This BB performs local Call Admission Control (CAC), and sends the request to the neighboring domain.
6. The BB of the neighboring domain also performs local CAC, and the request gets back to the destination domain. The BB of the destination domain - depending on the collected information and its resources - may accept or reject the request.

### 3. Implementation issues

Both our BB functions and the edge router control plane functionality are implemented in C programming language, while the policy database is stored in PostgreSQL.

Our BB implementation exhibits a modular architecture. The two pluggable modules are the *SQL module* and the *DFP module* that are connected to the core by predefined interfaces and can be exchanged. This is useful, if we for instance implemented a new

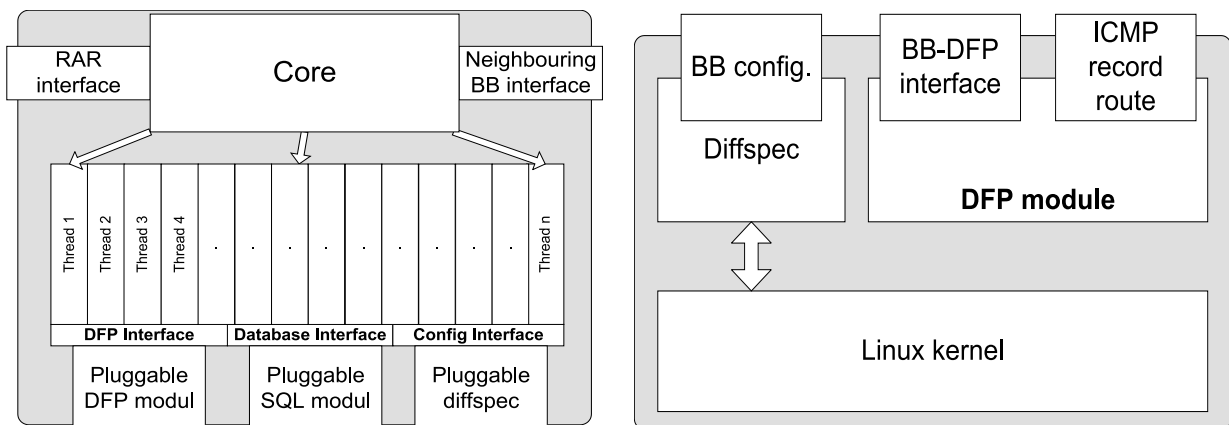

Fig. 4. BB and edge router implementation

DFP method or if one wants to replace the database server. The SQL module gives abstract access to a database and different implementations of the interface functions allow a given database to fit in the architecture seamlessly.

The BB core has two socket interfaces, which is supported to reach its services. One interface we defined for users to communicate with through the edge routers and one for neighboring BBs. Connection requests arrive to these sockets and the core runs threads for each request. The inter-domain request handling thread is not yet designed because there are considerations that interoperability issues should also be considered toward different vendor implementations. The user request handling thread accomplishes the CAC decision task after receiving the RAR from the user.

The edge router software consists of two parts. One of them is the *diffspec* daemon for configuring QoS mechanisms developed at University of Kansas [5] that handles the diffserv configuring requests of the BB (configures filters, meters, etc.). The other is the DFP handler that consists of two more processes. One to receive the DFP requests from the BB (ingress edge router) and send the IP addresses to the BB (egress edge router), while the other one launches the DFP packet (ingress) and catches them up (egress).

#### 4. Conclusions

In this paper we have presented a Bandwidth Broker (BB) architecture. In the BB approach to DiffServ networks a centralized automated resource manager performs admission control, resource provisioning and other policy decisions.

Our proposed architecture manages QoS resource allocation requests arriving at a DiffServ domain based on available resources and SLAs in effect among users and ISPs. Hence our BB provides policy and resource-based call admission control, as opposed to other proposed solutions.

Since we chose the centralized call admission model, we designed and implemented a lightweight route discovery technique. This is independent from the underlying routing protocol and domain topology, solves the path-changing problem by periodic queries and it does not require any modification of core router software.

We proposed a possible implementation of resource reservation for destination-requested flows, i.e., a backward resource reservation, based on ICMP-ECHO messages. At the best information of the authors neither the former problem nor its solutions are discussed in the literature.

#### 5. References

- [1] BLAKE, S., BLACK, D., CARLSON, M., DAVIES, E., WANG, Z., and WEISS, W.: *An Architecture for Differentiated Services*, IETF RFC 2475, December, 1998.
- [2] SHENKE, S., WROCLAWSKI, J.: *General Characterization Parameters for Integrated Services Network Elements*, IETF RFC 2215, 1997.
- [3] BERNET, Y., BINDER, J., BLAKE, S., CARLSON, M., CARPENTER, B. E., KESHAV, S., OHLMAN, B., VERMA, D., WANG, Z., WEISS, W.: *A Framework for Differentiated Services*, IETF-draft, <http://www.ietf.org>, 1999.
- [4] NEILSON, R., WHEELER, J., REICHMEYER, F., HARES, S.: *A Discussion of Bandwidth Broker Requirements for Internet2 Qbone Deployment*, August, 1999.
- [5] <http://www.ittc.ukans.edu/~kdrao/845/>
- [6] NICHOLS, K., JACOBSON, V., ZHANG, L.: *A Two-bit Differentiated Services Architecture for the Internet*, Internet-draft, 1999.
- [7] ZHI-LI ZHANG, ZHENHAI DUAN, LIXIN GAO, and YIWEI THOMAS HOU: *Decoupling QoS Control from Core Routers: A Novel Bandwidth Broker Architecture for Scalable Support of Guaranteed Services*, Sigcomm 2000
- [8] BRADEN, R., ZHANG, L., BERSON, S., HERZOG, S., JAMIN, S.: *Resource ReSerVation Protocol (RSVP) - Version 1 Functional Specification*, IETF RFC 2205
- [9] FEHÉR, G., NÉMETH, K., MALIOSZ, M., CSELÉNYI, I., BERGKVIST, J., AHLARD, D., ENGBORG, T.: *Boomerang - A Simple Protocol for Resource Reservation in IP Networks*, IEEE WS on QoS Support for Real-Time Internet Applications, Vancouver, Canada, June 1999
- [10] VIKTÓRIA ELEK, GUNNAR KARLSSON and ROBERT RÖNNGREN: *Admission Control Based on End-to-End Measurements*, IEEE INFOCOM 2000
- [11] BIANCHI, G., CAPONE, A., PETRIOLI, C.: *Throughput Analysis of End-to-End Measurement-Based Admission Control in IP*, IEEE INFOCOM 2000
- [12] HEINANEN, J., BAKER, F., WEISS, W., WROCLAWSKI, J.: *Assured Forwarding PHB Group*, IETF RFC-2597, 1999.
- [13] JACOBSON, V., NICHOLS, K., PODURI, K.: *An Expedited Forwarding PHB*, IETF RFC-2598, 1999.
- [14] SALLY FLOYD, KEVIN FALL: *Promoting the Use of End-to-End Congestion Control in the Internet*, IEEE/ACM Transactions on Networking, August 1999.

Luboš Buzna \*

# NÁVRH ŠTRUKTÚRY DISTRIBUČNÉHO SYSTÉMU S POUŽITÍM ÚDAJOV O SKUTOČNOM OSÍDLENÍ ZÁSOBOVANEJ OBLASTI

## THE DISTRIBUTION SYSTEM DESIGN PROBLEM APPLYING REAL SETTLEMENT DATA

*Obtížny spôsob získavania skutočných hodnôt vstupných parametrov je problematickým miestom návrhu štruktúry distribučného systému. Pre návrh štruktúry distribučného systému je v tomto článku použitá metóda spojitaj aproximácie. Hlavný prínos článku je v použití skutočných dát o osídlení okolia okresných miest, ktoré pokladáme za miesta vhodné na umiestnenie terminálu. Použitím týchto údajov získame podrobnejší model distribučného systému pre metódu spojitaj aproximácie. Umiestnenie jednotlivých terminálov určíme pomocou metódy využívajúcej schémy.*

### 1. Úvod

Úloha návrhu štruktúry distribučného systému je viacúrovňový rozhodovací problém. Úroveň rozhodnutia závisí od predpokladanej doby platnosti daného rozhodnutia. Počet a umiestnenie terminálov definujú strategické rozhodnutia. Rozhodnutia o pridelení zákazníkov a vozidiel ku terminálom sú určené na taktickej úrovni. Na operatívnej úrovni sa rozhoduje o časových a priestorových rozvrhoch vozidiel.

Terminál je miesto v distribučnom systéme, ktoré umožňuje manipuláciu a skladovanie distribuovaného tovaru. Tovar je nakladaný a vykladaný na vozidlá a presúvaný v rámci prekladiska. Predpokladáme, že každá jednotka tovaru na svojej ceste z primárneho zdroja k spotrebiteľovi prejde práve cez jeden terminál. Článok nadväzuje na vyjadrenie nákladov vznikajúcich v distribučnom systéme podľa Daganzo [1]. Hlavná snaha spočíva v čo najväčšom zrealnení priemernej vzdialenosti spotrebiteľa od terminálu, ktorá vystupuje vo vyjadrení dopravných nákladov. Toto spresnenie dosiahneme, keď použijeme skutočné údaje o osídlení Slovenskej republiky.

Vypočítame priemernú redukovanú hustotu rozmiestnenia obyvateľstva v závislosti od vzdialenosti zákazníka od možného umiestnenia terminálu (v našom prípade sú možnými umiestneniami terminálov všetky okresné mestá). Minimalizovaním takto spresnenej účelovej funkcie získame veľkosť plochy  $I$ , ktorú je optimálne obsluhovať z terminálu za uvedených predpokladov. Počet terminálov určíme podelením celkovej plochy plochou  $I$  a zaokrúhlením tejto hodnoty. Konkrétne umiestnenia terminálov získame pomocou prístupu využívajúceho schémy, ktorý je bližšie popísaný v Buzna [4].

*The complicated way of obtaining true values of entry parameters is a weaker part of distribution system design problem. This paper uses a continuous approximation approach to identify an optimal number of terminals. It is focused on applying real settlement data obtained from close surroundings of towns that are suitable for placing terminals. This more detailed information about settlement is used to obtain a more precise model for continuous approximation. The schemes location procedure is here used for a location of terminals.*

### 1. Introduction

In the distribution system design problem decisions are made at several levels. The level of the decision depends on time durability for which a decision is made. The number and terminal location are defined at a strategic level. Decisions about customers and vehicle allocations are assigned on a tactical level. Vehicle routes are designed at an operation level.

The terminal is a place in distribution system, where it is possible to tranship and store items. Items are loaded and unloaded at vehicles here and they are moved intraterminally. We assume that items pass exactly through one terminal during their transit from a primary source to a customer. This topic is based on a cost expression according Daganzo [1], the main goal is to obtain a more precise formulation of average distance from the terminal to a customer, which is used in the total cost expression. We can obtain this more detailed expression, when we use real data about the Slovak Republic.

We compute an average reduced spatial customer density, which depends on a customer distance from feasible terminal location (in our case that are all district towns). We will minimize this more detailed cost function and we will search a size of the influenced area, which is optimal, when all suppositions are satisfied. We obtain the exact number of terminals by dividing the total area by the influenced area. We determine the towns, in which terminals should be allocated by a procedure using schemes, which are described in Buzna [4].

\* Ing. Luboš Buzna

Faculty of Management Sciences and Informatics, University of Žilina, Moyzesova 20, SK-01026 Žilina, Slovak Republic

## 2. Metóda spojitých aproximácií

Princíp tejto metódy spočíva vo vyjadrení celkových jednotkových nákladov na dopravu, vznikajúcich pri preprave tovaru od primárneho zdroja až ku konečnému spotrebiteľovi, ako funkciu terminálom ovplyvnenej plochy  $I$ . Terminálom ovplyvnená plocha má kruhový tvar a terminál je umiestnený v strede tohoto kruhu. Predpokladáme, že všetky uvažované oblasti majú rovnakú veľkosť. Namiesto celkových nákladov za uvažované časové obdobie použijeme vyjadrenie jednotkových nákladov, ktoré má tento tvar:

$$f(I) = f_T(I) + f_o(I) + f_i(I) \quad (1)$$

Kde  $f_T(I)$  sú náklady vznikajúce v termináli (náklady na zriadenie terminálu a náklady na manipuláciu). Tieto náklady si môžeme vyjadriť nasledovne:

$$f_T(I) = \frac{f}{\lambda I}, \quad (2)$$

kde  $f$  predstavuje súčet fixných nákladov s manipulačnými nákladmi. Priemerná intenzita požiadaviek spotrebiteľa v  $[t/km^2.rok]$  je označená ako  $\lambda$ . Predpokladáme, že  $\lambda$  je na celej ploche oblasti  $R$  konštantná.

Náklady  $f_i(I)$  sú spôsobené dopravnou prácou pri zásobovaní terminálu z primárneho zdroja a nákladmi spôsobenými viazaním kapitálu v tovare počas jeho skladovania v termináli. Pre vyjadrenie týchto nákladov je potrebné urobiť tieto predpoklady. Predpokladáme, že trasy vozidiel majú tvar, primárny zdroj - terminál - primárny zdroj a tiež to, že vozidlá sú vždy plne naložené. Potom môžeme tieto náklady vyjadriť nasledovne:

$$f_i(I) = \frac{2n_1r_1(I)}{K_{1max}} + \frac{c_{1h}K_{1max}}{\lambda I}, \quad (3)$$

kde  $n_1$  sú jednotkové náklady na jeden kilometer jazdy vozidla zásobujúceho terminál,  $r_1(I)$  je priemerná vzdialenosť terminálu od primárneho zdroja. Ak predpokladáme obdĺžnikový tvar zásobovanej oblasti  $R$  s dĺžkou dlhšej strany  $L$  a polohu primárneho zdroja na kratšej strane obdĺžnika v polovici jej výšky (obr. 1), potom:

$$r_1(I) = \frac{L}{2} \quad (4)$$

O dopravnom parku zásobujúcom terminály budeme predpokladať, že je homogénny a že  $K_{1max}$  je maximálna kapacita vozidla,  $c_{1h}$  sú náklady na kapitál viazaný v jednej jednotke tovaru za plánovacie obdobie.

Poslednou zložkou nákladovej funkcie (1) sú náklady spôsobené zásobovaním spotrebiteľov z terminálu. Vyjadríme ich nasledovne:

$$f_o(I) = \frac{2n_0r_0(I)}{K_{0max}} + \frac{c_{oh}K_{0max}\delta}{\lambda}, \quad (5)$$

kde  $n_0$  sú jednotkové náklady na jednotkovú vzdialenosť vznikajúce pri zásobovaní spotrebiteľov,  $r_0(I)$  je priemerná vzdialenosť spo-

## 2. Continuous approximation approach

The principle of this approach is based on the expression of a total transport cost between the primary source and customers as a function of size of a terminal influenced area  $I$ . The terminal influenced area has a round shape and the terminal is situated in the middle. We assume that all the considered areas of each terminal have an equal size. Instead of the total cost during the time period we will use a proportional cost, which belongs to the pass a one item through the distribution system. This cost has the following form:

$$f(I) = f_T(I) + f_o(I) + f_i(I) \quad (1)$$

In the expression,  $f_T(I)$  is terminal cost (rent and handling cost for terminal). We can estimate  $f_T(I)$  by the following expression:

$$f_T(I) = \frac{f}{\lambda I}, \quad (2)$$

where  $f$  is sum of rent and handling costs. An average demand density rate [item/km<sup>2</sup>.year] is marked with symbol  $\lambda$ . We consider that  $\lambda$  is constant for the whole area  $R$ .

The inbound cost  $f_i(I)$ , which is caused by transport operations between the primary source and terminals and contains also pipeline inventory cost. If we want to express this cost, the following assumptions must be made. We assume that vehicle routes have the form of the primary source - terminal - primary source and vehicles travel fully loaded. Then  $f_i(I)$  can be expressed in the following way:

$$f_i(I) = \frac{2n_1r_1(I)}{K_{1max}} + \frac{c_{1h}K_{1max}}{\lambda I}, \quad (3)$$

where  $n_1$  is cost per vehicle - kilometer from the primary source to terminal and  $r_1(I)$  is an average distance from the primary source to terminal. We consider elongated shape of the area  $R$ , which is rectangular with length  $L$ . When the primary source is located by the edge in half of its height (Fig. 1), then:

$$r_1(I) = \frac{L}{2} \quad (4)$$

We suppose that the fleet i.e. vehicles traveling from the source to terminals is homogenous. The vehicles are capable to carry  $K_{1max}$  items. We consider that  $c_{1h}$  is a holding cost per item-day.

The last part (1) is an outbound cost expressing a delivery cost for customers from the terminal. We can write:

$$f_o(I) = \frac{2n_0r_0(I)}{K_{0max}} + \frac{c_{oh}K_{0max}\delta}{\lambda}, \quad (5)$$

where  $n_0$  is cost per vehicle-kilometer from the terminal to a customer and  $r_0(I)$  is an average distance from the terminal to a cus-

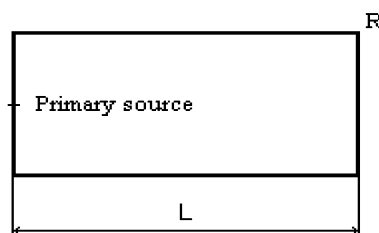

Obr. 1  
Fig. 1

trebitela od terminálu (jej popis je obsahom ďalšej kapitoly),  $K_{0\max}$  je maximálna kapacita vozidiel zásobujúcich spotrebiteľov,  $c_{oh}$  je cena kapitálu viazaného v jednej jednotke tovaru počas zásobovania spotrebiteľov (často  $c_{oh} = c_{1h}$ ) a  $\delta$  je priemerná priestorová hustota obyvateľstva (celkový počet obyvateľov rozpočítaný na celkovú plochu zásobovanej oblasti  $|R|$ ).

### 3. Priemerná vzdialenosť zákazníka od terminálu

Ak predpokladáme, že obsluhovaná oblasť  $R$  je rozdelená na rovnaké kruhové oblasti a terminál je umiestnený v strede týchto kruhov, potom môžeme priemernú vzdialenosť spotrebiteľa od terminálu vyjadriť v každej z oblastí nasledovne:

$$r_0(I) = \frac{\int_I d(x_r, x)h(x)dx}{\int_I h(x)dx}, \quad (6)$$

kde  $h(x)$  je hustota rozmiestnenia obyvateľov na ploche (počet zákazníkov na jednotku plochy),  $h(x)$  si vyjadríme v závislosti od vzdialenosti od terminálu  $r$ , teda budeme predpokladať, že body ležiace na kruhoch so stredom v mieste terminálu majú rovnakú hustotu osídlenia.

Pre všetky okresné mestá SR (okrem špecifickej Bratislavy a Košíc), ktoré považujeme za kandidátov na umiestnenie terminálu, sme zvolili počiatkový polomer kružnice 5 km, ktorý sme postupne zväčšovali o 0,3 km a v jednotlivých medzikružiach sme spočítali redukovanú hustotu osídlenia (počet zákazníkov - obyvateľov žijúcich v medzikruží podelený obsahom medzikružia). Redukovaná hustota osídlenia okolia mesta je hustota osídlenia, ktorá do okolia mesta (kandidáta na umiestnenie terminálu) nezapočítava obyvateľov miest, ktoré majú väčší počet obyvateľov ako je polovica počtu obyvateľov mesta, pre ktoré redukovanú hustotu vypočítavame. Pre toto obmedzenie sme sa rozhodli hlavne preto, lebo nepredpokladáme, že pri zásobovaní budeme voziť tovar z menších miest do väčších, ale skôr naopak. Získali sme takéto údaje o všetkých 69 okresných mestách, spriemerovali sme ich a vyhladili pomocou kľzavých priemerov a hľadali sme pre ne metódou najmenších štvorcov čo najlepšie analytické vyjadrenie. Pričom sme museli brať do úvahy tvar výrazu (6) a jeho integrovateľnosť. Ako najvhodnejšia sa ukázala funkcia:

$$h_a(r) = \frac{1}{ar + b} \quad (7)$$

pre hodnoty parametrov  $a = 0,000444$  a  $b = 0,017647$ . Výsledok zobrazuje graf č. 2. Výpočet hustoty sme uskutočnili pre 80 kilometrové okolie miest, čo pri teoretickom celkovom pokrytí plochy SR kružnicami zodpovedá trom kružniciam.

Hustotu  $h_a(r)$  sme získali priemerovaním redukovanej hustoty a preto nezodpovedá skutočnému počtu obyvateľov. Prepočítali sme  $h_a(r)$  tak, aby zodpovedala pre  $r \in (0,80)$  tretine počtu obyvateľov SR.

tomer (next chapter gives more details about  $r_0(I)$ ),  $K_{0\max}$  denote a maximum capacity of vehicles supplying customers,  $c_{oh}$  is a holding cost per item-day (usually  $c_{oh} = c_{1h}$ ) and  $\delta$  is a uniform spatial customer density [customer / area] (it is a total number of customers divided by the total size of area  $|R|$ ).

### 3. Average distance from customer to terminal

When we assume that the total area  $R$  is divided to equally circuit areas and terminals are situated in the middle of circles, then we can express the average distance from a customer to the terminal in the following way:

$$r_0(I) = \frac{\int_I d(x_r, x)h(x)dx}{\int_I h(x)dx}, \quad (6)$$

where  $h(x)$  is a spatial customer density (number of customers per unit area). We express  $h(x)$  as a function of distance customers from the terminal  $r$ . We will assume that points situated at the circle, which has its center in the terminal, have an equal spatial density.

For all district towns (without specific areas of Bratislava and Košice), which are candidates on the terminal, we chose an initial radius of circle a 5 km, we increased step by step this radius by 0.3 km and we computed a customers density rate in rings (number of customer - inhabitants divided by an area of ring). A reduced customer spatial density is a density of settlement in the surroundings of a town (candidate on terminal), which doesn't add customers situated in a town with more inhabitants than a half of inhabitants living in the studied town. We decided for this restriction, because we didn't consider to supply a bigger town from a smaller town. We obtained the data from all 69 district towns, we made averages and effaced this average curve with running averages. With the smallest square approach we found an analytic approximation of this curve, we had considered the formula (6) and its integral. The following formula fits our purpose best:

$$h_a(r) = \frac{1}{ar + b} \quad (7)$$

where parameters have the settings  $a = 0.000444$  and  $b = 0.017647$ . These curves are depicted in the Fig. 1. The computation we made for town circles surroundings with a radius of 80 km. To cover the Slovak Republic with those circles we would need three circles.

The  $h_a(r)$  was averaged and reduced and it is not equivalent to a real number of customers. We adapted  $h_a(r)$  to one third of inhabitants of SR for  $r \in (0,80)$ .

$$h(r) = \frac{1}{ar + b} + N = \frac{1}{0.000444 \cdot r + 0.017647} + 57,43 \quad (8)$$

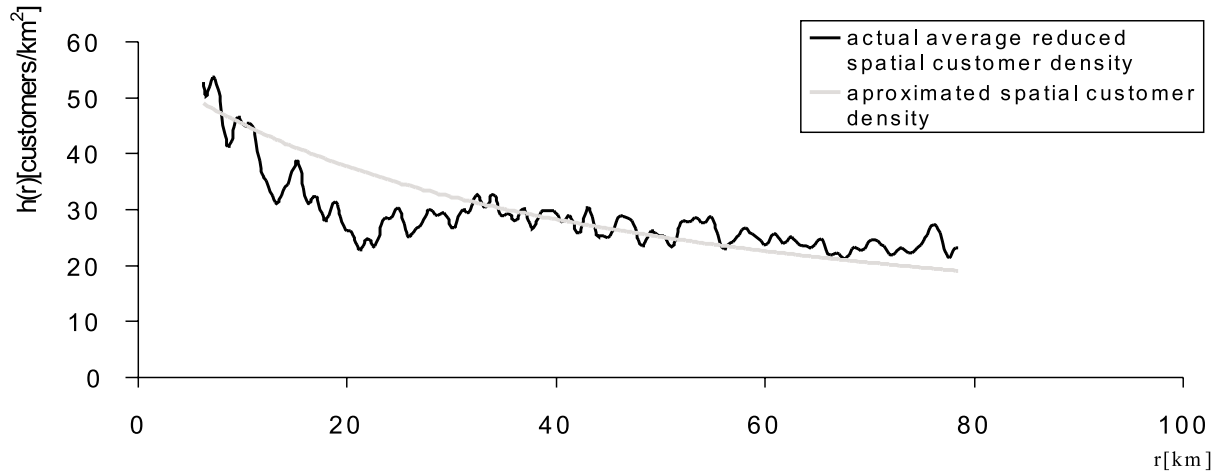

Obr. 2  
Fig. 2

Takto sme získali výsledný tvar hustoty osídlenia, ktorý sme použili pri výpočte priemernej vzdialenosti spotrebiteľa od termiálu, potom (1) bude mať tvar:

We obtained the final form of the spatial customer density function and we can use it for enumeration average distance customers from the primary source, then (1) has the following form:

$$f(I) = \frac{f}{\lambda I} + \frac{n_1 L}{K_{1\max}} + \frac{c_{1h} K_{1\max}}{\lambda I} + \frac{2n_0 \int_0^{\sqrt{\frac{1}{\pi}}} \left( \frac{r^2}{ar+b} + Nr^2 \right) dr}{K_{0\max}} + \frac{c_{oh} K_{0\max} \delta}{\lambda} \quad (9)$$

#### 4. Výpočtové experimenty

Použili sme rovnaké hodnoty vstupných parametrov ako v článku Buzna [4], aby sme získali lepšiu možnosť porovnania výsledkov s predchádzajúcim menej podrobným prístupom. Oblasť má plochu  $|R| = 49034 \text{ km}^2$  a dĺžku  $L = 418 \text{ km}$ . Maximálna kapacita vozidiel  $K_{1\max} = 80 \text{ t}$  a ich dopravné náklady sú  $n_1 = 10 \text{ Sk/km}$ , spotrebiteľa sú zásobovaní autami s maximálnou kapacitou  $K_{0\max} = 2,5 \text{ t}$  a ich náklady na dopravu sú  $n_0 = 5 \text{ Sk/km}$ . Priemerná priestorová hustota rozmiestnenia zákazníkov je  $\delta = 102,04 \text{ zákazníkov/km}^2$  pre SR a  $\lambda$  sme si určili ako  $\lambda = 3,4 \text{ t/(km}^2 \cdot \text{rok)}$ . Ostatné koeficienty sme predpokladali takto,  $c_{oh} = c_{1h} = 2000 \text{ Sk/(t.rok)}$  a  $f = 1\,500\,000 \text{ Sk}$ . Analytické vyjadrenie pre  $I^*$  sa nám nepodarilo nájsť, tak sme sa uspokojili s numerickým riešením. Graf č. 3 zobrazuje závislosť nákladovej funkcie (9) a nákladovej funkcie podľa článku Buzna [4], ktorá nezohľadňuje nerovnomerné osídlenie.

#### 4. Numerical experiments

We used the same entry parameters as Buzna in [4], to get a better possibility for comparison of results with a previous non-

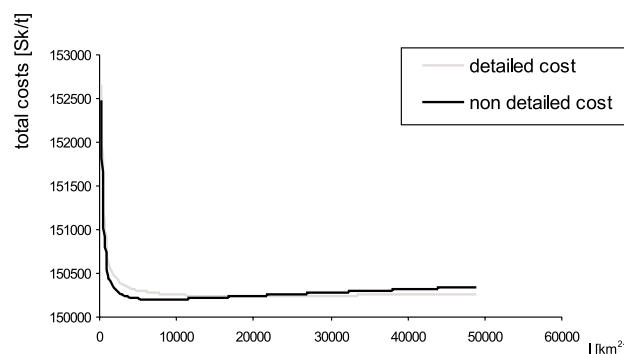

obr. 3  
Fig. 3

detailed approach. The region has an area  $|R| = 49034 \text{ km}^2$  and the length  $L = 418 \text{ km}$ . The maximum capacity of vehicles  $K_{1\max} = 80 \text{ t}$  and their  $n_1 = 10 \text{ Sk/km}$ , customers are supplied with vehicles capable of carrying  $K_{0\max} = 2.5 \text{ t}$  and their  $n_0 = 5 \text{ Sk/km}$ . The uniform spatial customer density is  $\delta = 102.04 \text{ customer/km}^2$  for SR and  $\lambda$  is determined as  $\lambda = 3.4$  (item

per year and square kilometer). Other coefficients we supposed this  $c_{oh} = c_{1h} = 2000 \text{ Sk/(item.year)}$  and  $f = 1\,500\,000 \text{ Sk}$ . We haven't found an analytical expression for  $I^*$ , we have satisfied the numerical solution. In fig. 2 are depicted cost (9) and non-detailed cost from Buzna [4].

Optimálna plocha zásobovaná z jedného terminálu, ktorá minimalizuje nákladovú funkciu (9) je pre dané vstupné údaje  $I^* = 19600 \text{ km}^2$ , čo zodpovedá trom terminálom. Postup umiestňujúci požadovaný počet stredísk na súvislej ploche využívajúci schému, ktorý je popísaný v Buzna [4], umiestnil terminály do týchto miest - Trnava, Zvolen a Gelnica.

## 5. Záver

Hlavným cieľom tejto práce bolo spresniť návrh štruktúry distribučného systému. Pri výpočte boli použité skutočné údaje o osídlení zásobovanej oblasti, ktoré boli spracované popísaným spôsobom. Z uvedených výsledkov vyplýva (pozri graf č. 1), že v blízkom okolí väčších miest je vyššia koncentrácia osídlenia, ktorá postupne so vzdialenosťou od terminálu klesá. Pretože hustota osídlenia nie je rovnomerná,  $r_0(I)$  je menšia, a preto aj celkový počet stredísk vyšiel menší (optimálny počet stredísk za predpokladu rovnomernej hustoty osídlenia pre dané vstupné údaje je šesť).

The optimal  $I^*$  is 19 600 km<sup>2</sup>. It corresponds to three terminals. The schemes location procedure described in Buzna [4] located terminals to Trnava, Zvolen and Gelnica.

## 5. Conclusion

The main goal of this paper was to obtain a more precise procedure to design the structure of distributions system. We used real data about settlement of the influenced area, which we treated in a described way. From the results we can see (Fig. 1) that in the closed surroundings towns the concentration of a settlement is bigger. The concentration is gradually descending with the distance from town. Because the concentration is not uniform the  $r_0(I)$  is smaller and the total number of the terminal is smaller too (optimal number of terminals for uniform density of settlement is six for this entry data).

## 6. Literatúra - References

- [1] DAGANZO, C. F.: *Logistics System Analysis*. Springer Verlag Berlin 1991, 1996, 341 s.
- [2] JANÁČEK, J.: *Tvorba regionů a výběr regionálních center*. In: Zborník príspevkov z medzinárodnej konferencie "Public Administration 2000", Lázne Bohdaneč, 23- 25.10.2000 s.81-85
- [3] JANÁČEK, J.: *Analysis and structure design of distribution systems*. In: proceedings of the International Conference "Strategic Management and its Support by Informations Systems", 8-10 Sept. 1999, Horní Bečva, p. 120-124
- [4] BUZNA, L.: *Návrh štruktúry distribučného systému pomocou spojitěj aproximácie* In: Zborník príspevkov medzinárodnej konferencie „Kvantitatívne metódy v ekonómii a podnikaní“, 29-30 marec 2001, s. 429-435
- [5] JANÁČEK, J., KOVÁČIKOVÁ, J.: *Exact Solution Techniques for Large Location Problems*. In: Proceedings of the Mathematical Meth. in Economics, Ostrava, Sept. 9-11, 1997, pp. 80-84

Peter Koteš – Josef Vičan – Jiří Slavík \*

# VPLYV KORÓZIE VÝSTUŽE NA SPOĽAHLIVOSŤ EXISTUJÚCICH BETÓNOVÝCH KONŠTRUKCIÍ

## INFLUENCE OF REINFORCEMENT CORROSION ON RELIABILITY OF EXISTING CONCRETE STRUCTURES

*Kvalita a trvanlivosť betónových konštrukcií sú ovplyvňované veľkým množstvom degradačných vplyvov. Článok sa zaoberá koróziou výstuže a jej vplyvom na spoľahlivosť existujúcich betónových konštrukcií. Pre zistenie vplyvu boli použité dva modely pre výpočet pasívneho štádia a dva modely pre výpočet aktívneho štádia. Na výpočet časovo závislej odolnosti konštrukcie sa použil pravdepodobnostný prístup. V závere článku je znázornená zmena pravdepodobnosti poruchy konštrukcie v čase a jej zodpovedajúci index spoľahlivosti v dôsledku korózie výstuže.*

### 1. Úvod

V súčasnosti sa naša krajina pripravuje na začlenenie do Európskej únie. Jedným z mnohých procesov, ktorý tejto snahe má pomôcť, je rozvoj dopravnej infraštruktúry.

Rozvoj dopravnej infraštruktúry je založený na jej modernizácii. Tento proces si vyžaduje veľké investície na dokončenie výstavby diaľnic a opravu existujúcich komunikácií. Avšak, zdroje týchto investícií pre údržbu a rehabilitáciu existujúcich dopravných stavieb sú obmedzené a dlhoročný nedostatok sa v budúcnosti bude prehľbovať. To núti užívateľov k maximálnym úsporám a k využitiu všetkých rezerv existujúcich konštrukcií. Tento stav dopravnej infraštruktúry nie je len v našej krajine, ale stretávame sa s ním aj v zahraničí.

Betónové mosty sú neodmysliteľnou časťou dopravnej infraštruktúry. V súčasnosti sa na našom území nachádza veľa betónových mostných konštrukcií, ktoré by sa mali rekonštruovať a opravovať za účelom ich ďalšieho využitia. Z tohto dôvodu je hodnotenie existujúcich mostných konštrukcií dôležitou časťou hospodárenia s mostnými objektmi (BMS) [1].

Za účelom stanovenia úrovne hladiny spoľahlivosti pri hodnotení existujúcich mostov bol vyvinutý matematický model využívajúci podmienenú pravdepodobnosť. V tomto matematickom modeli sa využívajú nové informácie týkajúce sa skutočného stavu konštrukcie, ktoré nie sú známe a dostupné pri návrhu novej konš-

*The quality and the durability of the concrete structures are affected by lots of degradation processes. The paper deals with reinforcement corrosion and its influence on the reliability of the existing concrete structures. Two types of passive stage calculation and two types of active stage calculation are considered in this paper. The probabilistic approach is used for the time dependent resistance solution. In conclusion, the change of the failure probability and reliability index of the structure in time influenced by reinforcement corrosion are shown.*

### 1. Introduction

Nowadays, our country tries to integrate to The European Union. Development of traffic infrastructure is one of the many components which should help this process.

Development of traffic infrastructure is based on its modernization. This process demands expensive investment for completion of motorways and innovation of roads. Resources of these investments for maintenance and rehabilitation strategy are limited and from now it is predicted that it will not be better. In terms of this we are forced to find and exploit all reserves of the existing structures. These problems are not just in our country, but it is a world-wide problem.

The concrete bridges are unthinkable part of the structures of the traffic infrastructure. At present, there are a lot of concrete structures in our country, which should be rebuilt and repaired on the ground of their other exploitation. On this account, evaluation of existing structures is the most important process in the bridge management system (BMS) [1].

In order to evaluate existing structures, a theoretical approach was developed using conditional probability. The new information concerning the actual structure condition is used in this mathematical model. This information is not available in the process of the new structure design. Periodic inspections regularly performed

\* <sup>1</sup>Ing. Peter Koteš, <sup>1</sup>doc.Ing. Josef Vičan, CSc., <sup>2</sup>doc. Mgr. Jiří Slavík, CSc.

<sup>1</sup>Department of Building Constructions and Bridges, Faculty of Civil Engineering, University of Žilina, Komenského 52, 010 26 Žilina  
Tel.: ++421-41-41868, Fax: ++421-41-41868, E-mail: kotes@fstav.uz.zilina.sk, vican@fstav.uz.zilina.sk

<sup>2</sup>Department of Transportation Networks, Faculty of Management Science, University of Žilina, Veľký diel, 010 26 Žilina  
Tel.: ++421-41-651015, Fax: ++421-41-651015

trukcie. Za hlavné zdroje týchto informácií sa považujú periodické prehliadky, pravidelne sa vykonávajúce počas životnosti pozorovanej konštrukcie. Získané nové informácie o konštrukcii, ktoré nie sú známe pri jej návrhu, sa môžu použiť pre overovanie skutočného chovania konštrukcie a taktiež pomáhajú redukovať neistoty týkajúce sa odolnosti konštrukcie, jej geometrických parametrov a zaťaženia.

Pozitívny výsledok prehliadky je podmienkou prežitia konštrukcie počas jej zvyškovej životnosti. Je to taký stav konštrukcie, v ktorej žiadny jej prvok neprekročí do doby prehliadky akýkoľvek z medzných stavov. Pomocou tohto prístupu je možné stanoviť novú vyššiu hladinu spoľahlivosti existujúcej konštrukcie a jej novú pravdepodobnosť poruchy pre zvyškovú životnosť. Možnosť použitia tohto prístupu je podmienená poznaním informácií získaných z pravidelne vykonávaných prehliadok mosta. Ďalej je možné spätne vypočítať pravdepodobnosť poruchy, na akú by sa mal prvok posúdiť, aby pri minimálne jednej prehliadke dosiahol požadovanú hodnotu cieľovej (návrhovej) pravdepodobnosti poruchy. Hore uvedený prístup je podrobne opísaný v [3].

V [4] sú znázornené hodnoty získaných pravdepodobnosti poruchy  $P_{fi}$  a indexov spoľahlivosti  $\beta_r$  pre hodnotenie prvkov existujúcich konštrukcií. Tieto hodnoty boli stanovené za predpokladu zanedbania degradácie materiálu.

Tento článok sa zaoberá reálnou degradáciou materiálu a jej vplyvom na spoľahlivosť existujúcich železobetónových konštrukcií.

## 2. Korózia výstuže ako degradácia betónového prvku

Za základný parameter spoľahlivosti stavebných konštrukcií považujeme rezervu spoľahlivosti  $G(t)$  [5], ktorú vyjadruje rovnica

$$G(t) = R(t) - S(t), \quad (1)$$

kde:  $R(t)$  zovšeobecnená funkcia odolnosti konštrukcie ako náhodnej premennej,

$S(t)$  sú náhodné premenné účinky zaťaženia toho istého prvku.

Z rovnice (1) vyplýva, že náhodná premenná odolnosť  $R(t)$ , náhodné premenné účinky zaťaženia  $S(t)$  a rezerva spoľahlivosti  $G(t)$  sú hodnoty premenné v čase.

Zmena odolnosti  $R(t)$  v čase je závislá od mnohých faktorov. Najvýznamnejšími parametrami ovplyvňujúcimi odolnosť v čase sú rôzne typy degradácie. Za najznámejší spôsob degradácie železobetónových konštrukcií je považovaná difúzia  $\text{CO}_2$  do betónového prvku, označovaná ako karbonatácia a následná korózia výstuže. Proces difúzie  $\text{CO}_2$  pozostáva z dvoch fáz [6]. Prvá fáza – *pasívne štádium*, predstavuje čas  $(0, t_0)$ , kedy  $\text{CO}_2$  preniká cez kryciu vrstvu. Počas tohoto štádia sa odolnosť prvku nemení. Dĺžka pasívneho štádia závisí od hrúbky krycej vrstvy. Druhá fáza – *aktívne štádium*, predstavuje čas  $(t_0, T)$ , odkedy  $\text{CO}_2$  prenikol cez kryciu vrstvu a dosiahol výstuž, na ktorú pôsobí až do konca životnosti  $T = 80$  rokov. V tomto čase  $\text{CO}_2$  spôsobuje koróziu výstuže.

within lifetime of the observed structure are main resources of this information. The obtained extra information unknown in the design phase can be used for verification of the correct structure performance and also helps to reduce some uncertainties related to the structure resistance, measurements and load parameters.

The positive result of inspection is condition of survival of a structure in the remaining lifetime. It means that any component of structure has not exceeded any limit states until inspection time. Through this positive information we are able to determine new higher reliability level of the existing structure and its new failure probability for the remaining lifetime. It is impossible without new information obtained from the regularly performed inspections. Next we are able to solve back the failure probability for which the element should be evaluated so that we can achieve the required value of the target failure probability with minimal one inspection. This approach is described in [3].

The obtained values of failure probability  $P_{fi}$  and reliability index  $\beta_r$  for assessment of existing structure members are shown in [4]. These values were established providing that a material degradation is neglected.

This paper deals with a problem of an actual material degradation and its influence on reliability of the existing concrete structures.

## 2. Reinforcement corrosion as a degradation of concrete member

The reliability margin  $G(t)$  [5] is the basic parameter of structural reliability and it is described by formula

$$G(t) = R(t) - S(t), \quad (1)$$

where  $R(t)$  is the generalized function of a random variable structural resistance,

$S(t)$  are random variable load effects of the same element.

As we can see from formula (1), random variable resistance  $R(t)$ , random variable load effect  $S(t)$  and reliability margin  $G(t)$  are values dependent on time  $t$ .

The resistance  $R(t)$  has been changed in time due to many factors. The different types of degradation are the best-known factors changing the resistance in time. The most significant way of degradation of concrete structures is diffusion of  $\text{CO}_2$  to the concrete member called as a carbonization, and consecutive reinforcement corrosion. This process of  $\text{CO}_2$  diffusion consists of two phases [6]. The first phase – *passive stage* means time  $(0, t_0)$ , when  $\text{CO}_2$  penetrates through the concrete cover. In this time the resistance of element is not changed. The length of the passive stage depends on the cover depth. The second phase – *active stage* means time  $(t_0, T)$ , from when  $\text{CO}_2$  penetrated through the concrete cover and achieved reinforced bars to the end of member life  $T = 80$  years. During this time,  $\text{CO}_2$  induces the corrosion of reinforced bars.

V následnej parametrickej štúdií bol uvažovaný ohýbaný železobetónový prvok. Odolnosť  $R(t)$  ohýbaného železobetónového prvku je daná rovnicou, odvodenou v [2]

$$R(t) = \frac{A_{s,n}^2 \cdot f_{s,n}^2}{b_n \cdot f_{c,n}} \times \left[ 0.5 \cdot \varphi_{wc}(t) \cdot \varphi_{fc} + \varphi_{ws}(t) \cdot \varphi_{fs} \cdot \left( \frac{1}{\xi_n} - 1 \right) \right], \quad (2)$$

kde:  $A_{s,n}$  je nominálna hodnota prierezovej plochy výstuže [ $\text{m}^2$ ],

$$A_{s,n} = \frac{\pi}{4} \cdot d_{s,n}^2, \quad (3)$$

$f_{s,n}$  je nominálna hodnota medze klzu výstuže [MPa],  
 $f_{c,n}$  je nominálna hodnota pevnosti betónu [MPa],  
 $b_n$  je nominálna hodnota šírky prierezu [m],

$$\xi_n = \frac{A_{s,n} \cdot f_{s,n}}{b_n \cdot \left( h_n - c_n - \frac{d_{s,n}}{2} \right) \cdot f_{c,n}}, \quad (4)$$

$h_n$  je nominálna hodnota výšky prierezu [m],  
 $c_n$  je nominálna hodnota hrúbky krycej vrstvy [m],  
 $d_{s,n}$  je nominálna hodnota priemeru výstuže [m],

$$\varphi_{fc} = \frac{f_c}{f_{c,n}}; \quad \varphi_{fs} = \frac{f_s}{f_{s,n}}, \quad (5)(6)$$

$f_c$  je pevnosť betónu v tlaku [MPa],  
 $f_s$  je medza klzu výstuže [MPa],

In the parametric study, the concrete element subjected to bending was considered. Resistance  $R$  of bending concrete element is given by formula, derived in [2]

where:  $A_{s,n}$  is the nominal value of the reinforcement cross-section area [ $\text{m}^2$ ],

$$A_{s,n} = \frac{\pi}{4} \cdot d_{s,n}^2, \quad (3)$$

$f_{s,n}$  is the nominal value of reinforcement yield strength [MPa],

$f_{c,n}$  is the nominal value of concrete strength [MPa],  
 $b_n$  is the nominal value of cross section width [m],

$$\xi_n = \frac{A_{s,n} \cdot f_{s,n}}{b_n \cdot \left( h_n - c_n - \frac{d_{s,n}}{2} \right) \cdot f_{c,n}}, \quad (4)$$

$h_n$  is the nominal value of cross-section height [m],

$c_n$  is the nominal value of concrete covering [mm],

$d_{s,n}$  is the nominal value of reinforcement diameter [mm],

$$\varphi_{fc} = \frac{f_c}{f_{c,n}}; \quad \varphi_{fs} = \frac{f_s}{f_{s,n}}, \quad (5)(6)$$

$f_c$  is the concrete strength [MPa],

$f_s$  is the reinforcement yield strength [MPa],

$$\varphi_{wc}(t) = \left( \frac{b_n \cdot f_{c,n}^2}{A_{s,n}^2 \cdot f_{s,n}^2} \right) \cdot \frac{A_s^2(t) \cdot f_s^2}{b \cdot f_c^2}, \quad (7)$$

$$\varphi_{ws}(t) = \frac{1}{A_{s,n} \cdot \left( h_n - c_n - \frac{d_{s,n}}{2} - \frac{A_{s,n} \cdot f_{s,n}}{b_n \cdot f_{c,n}} \right)} \cdot A_{st}(t) \cdot \left( h - c - \frac{d_s(t)}{2} - \frac{A_s(t) \cdot f_s}{b \cdot f_d} \right), \quad (8)$$

kde  $h$  je výška prierezu [m],  
 $b$  je šírka prierezu [m],  
 $c$  je hrúbka krycej vrstvy [m],  
 $d_s(t)$  je priemer výstuže závislý od času [m],  
 $A_s(t)$  je plocha výstuže závislá od času [ $\text{m}^2$ ],

$$A_s = \frac{\pi}{4} \cdot d_s^2, \quad (9)$$

Veličiny  $b$ ,  $c$ ,  $h$ ,  $f_c$  a  $f_s$  sú náhodné premenné.

Označenie rozmerov je na obr. 1

Z rovnice (9) vyplýva, že zmena odolnosti  $R(t)$  v čase závisí od úbytku prierezovej plochy výstuže. Pre výpočet úbytku prierezovej plochy výstuže boli uvažované dva prístupy. Ako prvý sa uvažoval model korózie podľa Andradeiho [7] (pozri obr. 2), ktorý je jeden z najviac používaných modelov korózie výstuže. Zmena priemeru výstuže  $d_s(t)$  pre plošnú koróziu je opísaná rovnicou

$$d_s(t) = d_s - 0,0232 \cdot (t - t_0) \cdot i_{corr}, \quad (10)$$

where  $h$  is the cross-section height [m],  
 $b$  is the cross-section width [m],  
 $c$  is the concrete covering [m],  
 $d_s(t)$  is the reinforcement diameter dependent on time [m],  
 $A_s(t)$  is the reinforcement cross-section area dependent on time [ $\text{m}^2$ ],

$$A_s = \frac{\pi}{4} \cdot d_s^2, \quad (9)$$

Quantities of  $b$ ,  $c$ ,  $h$ ,  $f_c$ , and  $f_s$  are considered to be random variables.

Denotations of dimensions are shown in fig. 1

From formula (9), it can be seen that the change of resistance  $R(t)$  in time depends on the lost of reinforcement cross-section area. Two approaches to the calculation of the reinforcement cross-section area loss were considered. The first corrosion model according to Andrade [7] (see fig. 2) was considered. This model of corrosion is one of the most used models. Loss of diameter  $d_s(t)$  for uniform corrosion is described by formula

$$d_s(t) = d_s - 0.0232 \cdot (t - t_0) \cdot i_{corr}, \quad (10)$$

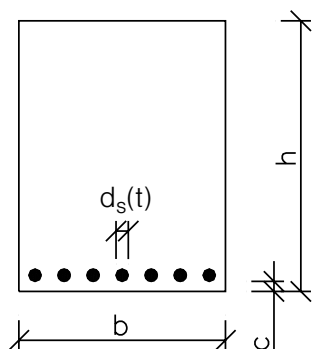

Obr. 1. Schéma označenia rozmerov  
Fig. 1. Scheme of profile denotation

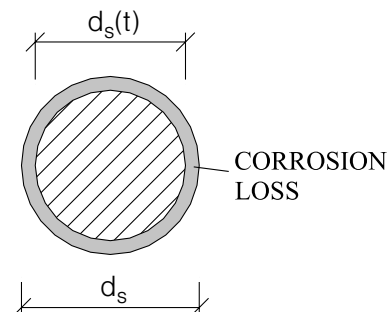

Obr. 2. Úbytok prierezovej plochy  
Fig. 2. Loss of cross section area

kde:  $i_{corr}$  je hustota prúdovej korózie [ $\mu\text{A}/\text{cm}^2$ ],  
(1  $\mu\text{A}/\text{cm}^2$  predstavuje 11,6  $\mu\text{m}/\text{rok}$  skorodovanej vrstvy),  
 $t_0$  je dĺžka pasívneho štádia.

Ďalší korozívny model bol uvažovaný podľa Thoft-Christensena [9] (viď obr. 2). Zmena priemeru výstuže  $d_s(t)$  je opísaná rovnicou

$$d_s(t) = d_s - (t - t_0) \cdot r_{corr}, \quad (11)$$

kde:  $r_{corr}$  stupeň korózie [ $\mu\text{m}/\text{rok}$ ],  
 $t_0$  je dĺžka pasívneho štádia.

Hustota prúdovej korózie  $i_{corr}$  a stupeň korózie  $r_{corr}$  boli merané na skutočných mostných konštrukciách [7], [8], [9] a sú opísané v tab. 1.

Začiatok zmeny odolnosti v čase závisí na dĺžke pasívneho štádia. Proces difúzie  $\text{CO}_2$  sa riadi druhým Fickovým zákonom [10]

$$\frac{\partial C}{\partial t} = D_{eff} \cdot \frac{\partial^2 C}{\partial x^2}, \quad (12)$$

kde:  $C$  je koncentrácia agresívnych látok,  
 $D_{eff}$  je koeficient difúzie.

Pre praktické využitie bolo odvodených niekoľko modelov difúzie  $\text{CO}_2$ . Proces difúzie v týchto modeloch závisí od rôznych faktorov.

V prezentovanej parametrickej štúdií boli použité dva modely výpočtu pasívneho štádia. V prvom použitom modeli je dĺžka pasívneho štádia závislá od hrúbky krycej vrstvy  $c$  a materiálnej konštanty  $D$ . Uvedený model je jednoduchý a je opísaný v rôznych prácach, napríklad [11]. Dĺžka pasívneho štádia sa vypočíta zo vzťahu

$$t_0 = \frac{c^2}{2 \cdot D}, \quad (13)$$

kde:  $D$  je materiálová konštantá uvedená v tab. 2 podľa [11].

Druhý použitý model podľa Freya [12] je presnejší, ale je veľmi problematické získať hodnoty konštant potrebných v tomto modeli. Hĺbka skarbonizovanej vrstvy v čase je daná rovnicou

where:  $i_{corr}$  is the corrosion current density [ $\mu\text{A}/\text{cm}^2$ ],  
(1  $\mu\text{A}/\text{cm}^2$  is equal to 11,6  $\mu\text{m}/\text{year}$  of corrosion),  
 $t_0$  is time of passive stage.

Next, the second model of corrosion according to Thoft-Christensen [9] (see fig. 2) was considered. Loss of diameter  $d_s(t)$  is described by formula

$$d_s(t) = d_s - (t - t_0) \cdot r_{corr}, \quad (11)$$

where:  $r_{corr}$  is the corrosion rate [ $\mu\text{m}/\text{year}$ ],  
 $t_0$  is time of passive stage.

The corrosion current density  $i_{corr}$  and the corrosion rate  $r_{corr}$  were measured on the real bridge structures [7], [8], [9] and their values are shown in tab. 1.

The start of the resistance changing in time depends on the length of the passive stage. The process of  $\text{CO}_2$  diffusion is described by the second Fick's law [10]

$$\frac{\partial C}{\partial t} = D_{eff} \cdot \frac{\partial^2 C}{\partial x^2}, \quad (12)$$

where  $C$  is the concentration of aggressive subject,  
 $D_{eff}$  is the diffusion coefficient.

Many models of  $\text{CO}_2$  diffusion were deduced for practical use. These models depend on various factors.

Two models of passive stage calculation were used in the parametric study. In the first model it is described that the length of the passive stage depends on the concrete cover  $c$  and material constant  $D$ . This model is simple and it is described in many references, for example [11]. Length of passive stage is given by formula

$$t_0 = \frac{c^2}{2 \cdot D}, \quad (13)$$

where:  $D$  is a material constant presented in tab. 2 by [11].

The second model by Frey [12] is more precise than the first model, but it is difficult to get the constants for this model. The depth of carbonation layer in time is given by formula

$$d_k = (e^{A \cdot w^{-2}} - 1) \cdot (1 - e^{-w \cdot \sqrt{t}}), \quad (14)$$

kde  $A, w$  sú konštanty závislé od prostredia (pozri tab. 2).

V prípade vzťahu (14) sa dĺžka pasívneho štádia  $t = t_0$  vypočíta, keď sa položí  $d_k = c$ . Veličiny  $h, b, c, d_s, f_c, f_s, i_{corr}$  a  $r_{corr}$  v rovniciach (7-11) sú náhodné premenné s normálnym rozdelením. Štatistické charakteristiky premenných sú znázornené v tab. 1.

Tab. 1

Premenné	Stredná hodnota	Smerodajná odchýlka	Variačný koeficient
Medza klzu - $f_s$ [MPa]	400,81480	23,96686	0,06800
Pevnosť betónu - $f_c$ [MPa]	24,64000	2,68000	0,10877
Výška prierezu - $h$ [m]	0,797800	0,01360	0,01705
Šírka prierezu - $b$ [m]	0,49570	0,00740	0,01493
Priemer výstuže - $d_s$ [mm]	19,770	0,223	0,01128
Hrúbka krycia vrstva - $c$ [mm]	24,00	1,30	0,05417
Hustota prúdovej korózie - $i_{corr}$ [ $\mu\text{A}/\text{cm}^2$ ]	1,00	0,20	0,20
	3,00	0,60	0,20
Stupeň korózie - $r_{corr}$ [ $\mu\text{m}/\text{rok}$ ]	50,70	5,80	0,11440

V priereze bolo uvažovaných 7 prútov výstuže.

Hodnoty premenných z tab. 1 a konštánt z tab. 2 boli zistené meraním na skutočných mostných konštrukciách [7], [8], [9] a [10].

Tab. 2

Konštanta - $A$ [ $\text{rok}^{-1}$ ] (pre centrálnu Európu)	0,11
Konštanta - $w$ [ $\text{rok}^{-0,5}$ ]	0,170
	0,160
Materiálová konštanta - $D$ [ $\text{mm}^2 \cdot \text{s}^{-1}$ ]	$2,84 \cdot 10^{-7}$
	$4,82 \cdot 10^{-7}$

Konkrétna numerická aplikácia výpočtu časovo závislej odolnosti  $R(t)$  bola realizovaná pomocou simulačnej metódy Monte-Carlo. Na simuláciu je možné použiť aj iné známe metódy, ako napríklad LHS, Importance sampling [13] a iné. Získané výsledky simulácie boli pre ďalšie použitie aproximované matematickými závislosťami v tvare

$$m_R(t) = m_R + p_1 \cdot t + p_2 \cdot t^2, \text{ respekt. } s_R(t) = s_R + p_3 \cdot t + p_4 \cdot t^2 \quad (15)$$

kde:  $m_R$  a  $s_R$  sú stredná hodnota a smerodajná odchýlka odolnosti prvku podľa (2),

$p_1, p_2, p_3, p_4$  sú konštanty.

Výsledky simulácií sú znázornené na obr. 3 a obr. 4.

V parametrickej štúdií bol simulovaný priečný rez s náhodne premennými parametrami  $f_s, f_c, h, b, d_s, c$  (pozri tab. 1), ktorých rozdelenia sa v priebehu výpočtu nemenili. Odlišná bola len metóda výpočtu pasívneho a aktívneho štádia korózie výstuže, čiže

$$d_k = (e^{A \cdot w^{-2}} - 1) \cdot (1 - e^{-w \cdot \sqrt{t}}), \quad (14)$$

where  $A, w$  are constants dependent on the environment (see tab. 2).

The length of passive stage  $t = t_0$  is calculated from (14) when  $d_k = c$  (concrete cover). Values of  $h, b, c, d_s, f_c, f_s, i_{corr}$  and  $r_{corr}$  in relations (7-11) are normally distributed random variables. The statistical characteristics of variables are given in tab. 1.

Tab. 1

Variables	The mean value	The standard deviation	Coefficient of variation
Yield strength - $f_s$ [MPa]	400.81480	23.96686	0.06800
Strength of concrete - $f_c$ [MPa]	24.64000	2.68000	0.10877
Height - $h$ [m]	0.797800	0.01360	0.01705
Width - $b$ [m]	0.49570	0.00740	0.01493
Bar diameter - $d_s$ [mm]	19.770	0.223	0.01128
Concrete cover - $c$ [mm]	24.00	1.30	0.05417
Corrosion current density - $i_{corr}$ [ $\mu\text{A}/\text{cm}^2$ ]	1.00	0.20	0.20
	3.00	0.60	0.20
Corrosion rate - $r_{corr}$ [ $\mu\text{m}/\text{year}$ ]	50.70	5.80	0.11440

The number of reinforcement bars was equal to 7.

The values of variables in tab. 1 and constants in tab. 2 were measured on the real bridge structures [7], [8], [9] and [10].

Tab. 2

Constant - $A$ [ $\text{year}^{-1}$ ] (for central Europe)	0,11
Constant - $w$ [ $\text{year}^{-0,5}$ ]	0,170
	0,160
Material constant - $D$ [ $\text{mm}^2 \cdot \text{s}^{-1}$ ]	$2,84 \cdot 10^{-7}$
	$4,82 \cdot 10^{-7}$

Numerical application calculating time dependent resistance  $R(t)$  was realized by simulation of Monte-Carlo method. It is possible to use other methods for simulation, for example LHS, Importance sampling [13] etc. For further use, results of simulation were approximated by mathematical relations given by formula

where:  $m_R$  and  $s_R$  are mean values and standard deviation of the element resistance in accordance with (2),

$p_1, p_2, p_3, p_4$  are constants.

The results of simulation are shown in Fig. 3 and Fig. 4.

There was simulated one cross-section with variables parameters  $f_s, f_c, h, b, d_s, c$  (see tab. 1), whose distributions were not changed during calculation. The different methodology of the passive and active stage calculating has been used so that the para-

menili sa parametre  $D$ ,  $w$ ,  $i_{corr}$  a  $r_{corr}$ . Blížšie je priradenie kriviek k jednotlivým modelom výpočtu pasívneho a aktívneho štádia opísané v tab. 3.

meters of  $D$ ,  $w$ ,  $i_{corr}$  and  $r_{corr}$  have been changed. The curve assignment of relevant approach to the passive and active stage calculating is shown in tab. 3.

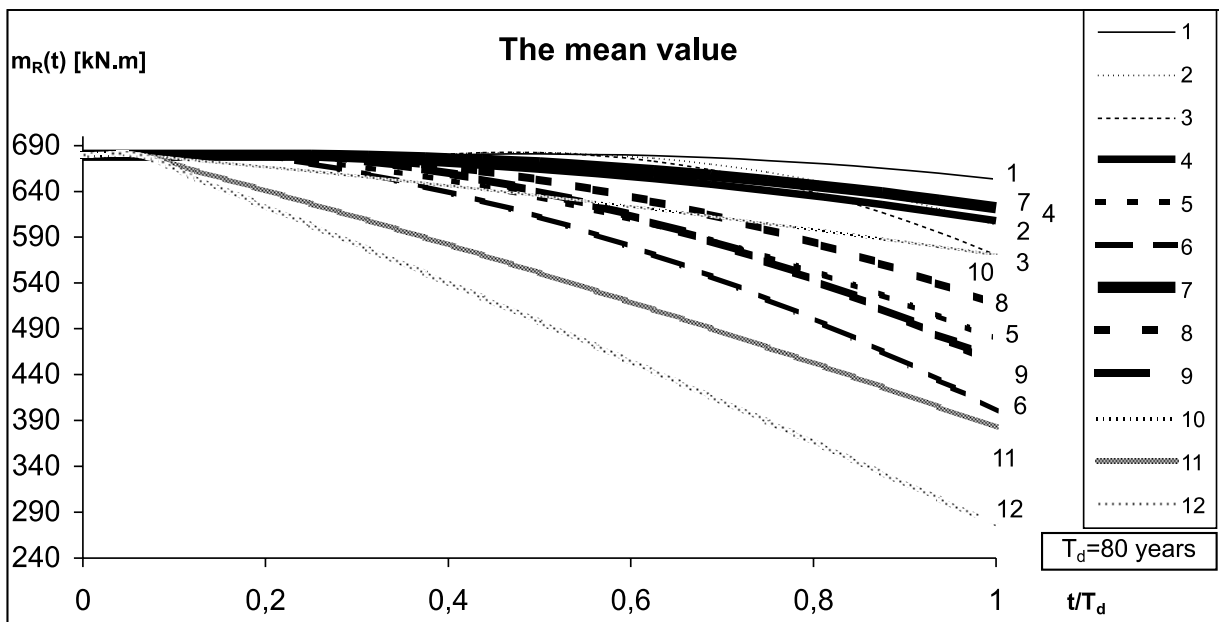

Obr. 3. Časovo závislá stredná hodnota odolnosti  $R(t)$   
Fig. 3. Time dependent mean value of resistance  $R(t)$

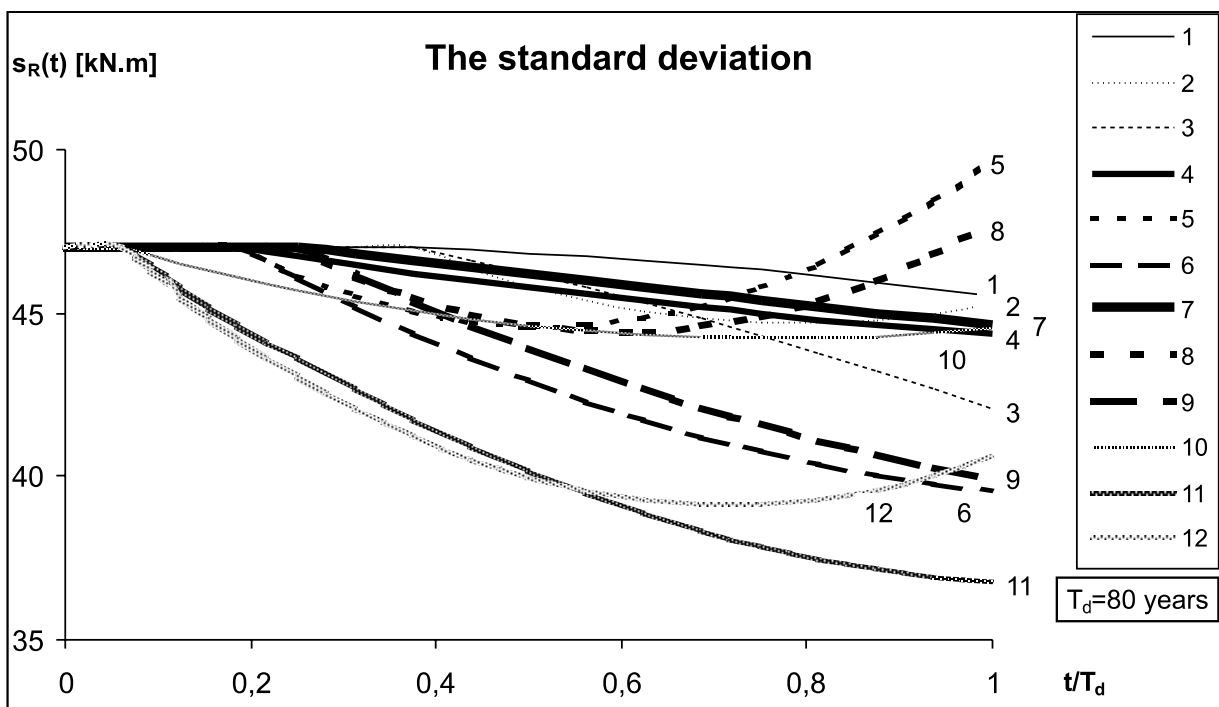

Obr. 4. Časovo závislá smerodajná odchýlka odolnosti  $R(t)$   
Fig. 4. Time dependent standard deviation of resistance  $R(t)$

Tab.3

Označ.	Výpočet pasívneho štádia	Výpočet aktívneho štádia
1	$D = 2,84 \cdot 10^{-7} \text{ mm}^2 \cdot \text{s}^{-1}$	$i_{corr} = (1,0; 0,2)$
2	$D = 2,84 \cdot 10^{-7} \text{ mm}^2 \cdot \text{s}^{-1}$	$i_{corr} = (3,0; 0,6)$
3	$D = 2,84 \cdot 10^{-7} \text{ mm}^2 \cdot \text{s}^{-1}$	$r_{corr} = (50,7; 5,80)$
4	$D = 4,82 \cdot 10^{-7} \text{ mm}^2 \cdot \text{s}^{-1}$	$i_{corr} = (1,0; 0,2)$
5	$D = 4,82 \cdot 10^{-7} \text{ mm}^2 \cdot \text{s}^{-1}$	$i_{corr} = (3,0; 0,6)$
6	$D = 4,82 \cdot 10^{-7} \text{ mm}^2 \cdot \text{s}^{-1}$	$r_{corr} = (50,7; 5,80)$
7	$w = 0,170 \text{ rok}^{-0,5}$	$i_{corr} = (1,0; 0,2)$
8	$w = 0,170 \text{ rok}^{-0,5}$	$i_{corr} = (3,0; 0,6)$
9	$w = 0,170 \text{ rok}^{-0,5}$	$r_{corr} = (50,7; 5,80)$
10	$w = 0,160 \text{ rok}^{-0,5}$	$i_{corr} = (1,0; 0,2)$
11	$w = 0,160 \text{ rok}^{-0,5}$	$i_{corr} = (3,0; 0,6)$
12	$w = 0,160 \text{ rok}^{-0,5}$	$r_{corr} = (50,7; 5,80)$

Tab.3

Denot.	Passive stage calculating	Active stage calculating
1	$D = 2,84 \cdot 10^{-7} \text{ mm}^2 \cdot \text{s}^{-1}$	$i_{corr} = (1,0; 0,2)$
2	$D = 2,84 \cdot 10^{-7} \text{ mm}^2 \cdot \text{s}^{-1}$	$i_{corr} = (3,0; 0,6)$
3	$D = 2,84 \cdot 10^{-7} \text{ mm}^2 \cdot \text{s}^{-1}$	$r_{corr} = (50,7; 5,80)$
4	$D = 4,82 \cdot 10^{-7} \text{ mm}^2 \cdot \text{s}^{-1}$	$i_{corr} = (1,0; 0,2)$
5	$D = 4,82 \cdot 10^{-7} \text{ mm}^2 \cdot \text{s}^{-1}$	$i_{corr} = (3,0; 0,6)$
6	$D = 4,82 \cdot 10^{-7} \text{ mm}^2 \cdot \text{s}^{-1}$	$r_{corr} = (50,7; 5,80)$
7	$w = 0,170 \text{ year}^{-0,5}$	$i_{corr} = (1,0; 0,2)$
8	$w = 0,170 \text{ year}^{-0,5}$	$i_{corr} = (3,0; 0,6)$
9	$w = 0,170 \text{ year}^{-0,5}$	$r_{corr} = (50,7; 5,80)$
10	$w = 0,160 \text{ year}^{-0,5}$	$i_{corr} = (1,0; 0,2)$
11	$w = 0,160 \text{ year}^{-0,5}$	$i_{corr} = (3,0; 0,6)$
12	$w = 0,160 \text{ year}^{-0,5}$	$r_{corr} = (50,7; 5,80)$

### 3. Časovo závislá pravdepodobnosť poruchy $P_f(t)$

Pravdepodobnosť poruchy prvku  $P_f(t)$  je časovo závislá a je definovaná rovnicou podľa [3]

$$P_f(t) = P(G(t) < 0) = 1 - \int_{-\infty}^{\infty} F(x) \int_0^t \varphi\left(\frac{x - m_R(\tau)}{s_R(\tau)}\right) \cdot \frac{1}{s_R(\tau)} \cdot f(\tau) d\tau dx, \quad (16)$$

kde

$$F(x) = e^{-L(t) \left[ 1 - \int_0^t \varphi\left(\frac{x - m_s(\tau)}{s_s(\tau)}\right) s(\tau) d\tau \right]}, \quad L(t) = \int_0^t \lambda(\tau) d\tau, \quad (17)$$

je distribučná funkcia náhodne premennej odozvy zaťaženia  $S$  so strednou hodnotou  $m_s(t)$  a smerodajnou odchýlkou  $s_s(t)$ .

### 3. Time dependent failure probability $P_f(t)$

The element probability of failure  $P_f(t)$  is time dependent and it is defined using formula according to [3]

where

$$F(x) = e^{-L(t) \left[ 1 - \int_0^t \varphi\left(\frac{x - m_s(\tau)}{s_s(\tau)}\right) s(\tau) d\tau \right]}, \quad L(t) = \int_0^t \lambda(\tau) d\tau, \quad (17)$$

is the distribution function of random variable load effects  $S$  with mean value  $m_s(t)$  and standard deviation  $s_s(t)$ .

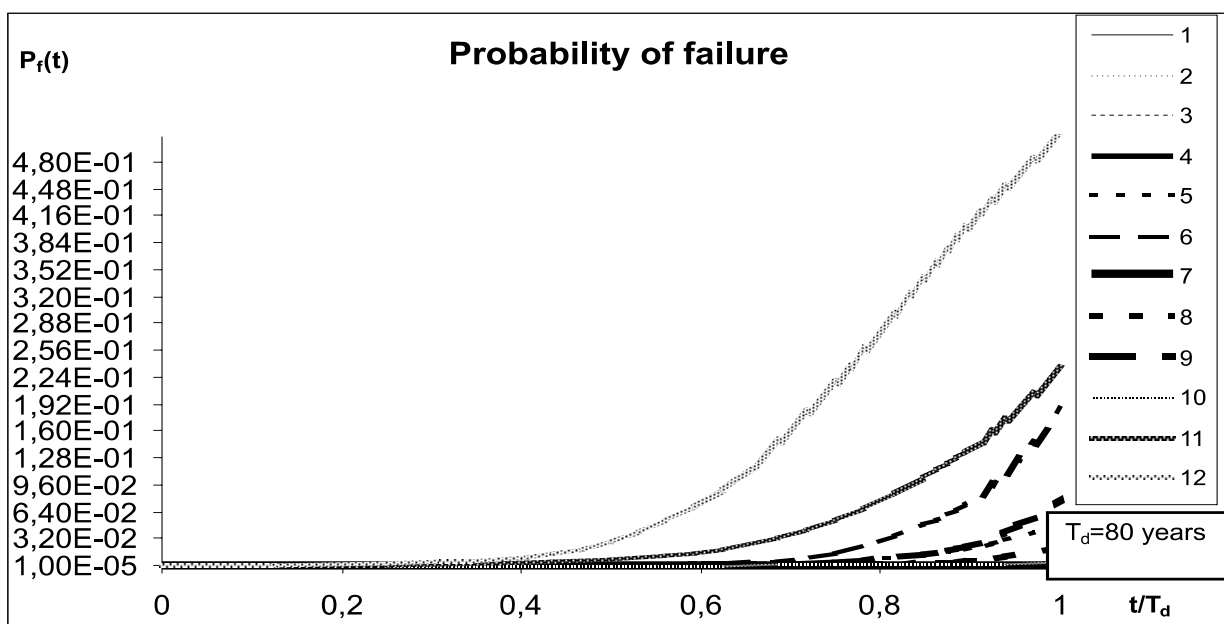

Obr. 5. Časovo závislá pravdepodobnosť poruchy  $P_f(t)$  ohybaného prvku napadnutého koróziou  
Fig. 5. Time dependent failure probability  $P_f(t)$  of bending member under corrosion attack

Odozva zaťaženia  $S$  je chápaná ako séria normálne rozdelených účinkov zaťaženia opakovane sa vyskytujúcich v čase a radiaciach sa Poissonovým rozdelením s parametrom  $\lambda(\tau) = 1/80 = 0,0125$ . Výsledky výpočtov pravdepodobnosti poruchy prvku  $P_f(t)$  a jej zodpovedajúcim indexom spoľahlivosti  $\beta(t)$  sú znázornené na obr. 5 a obr. 6.

Load effects  $S$  are normally distributed random variables in time having Poisson distribution with parameter  $\lambda(\tau) = 1/80 = 0.0125$ . Results of simulation of the element failure probability  $P_f(t)$  and correspondent reliability index  $\beta(t)$  are shown in Fig. 5 and Fig. 6.

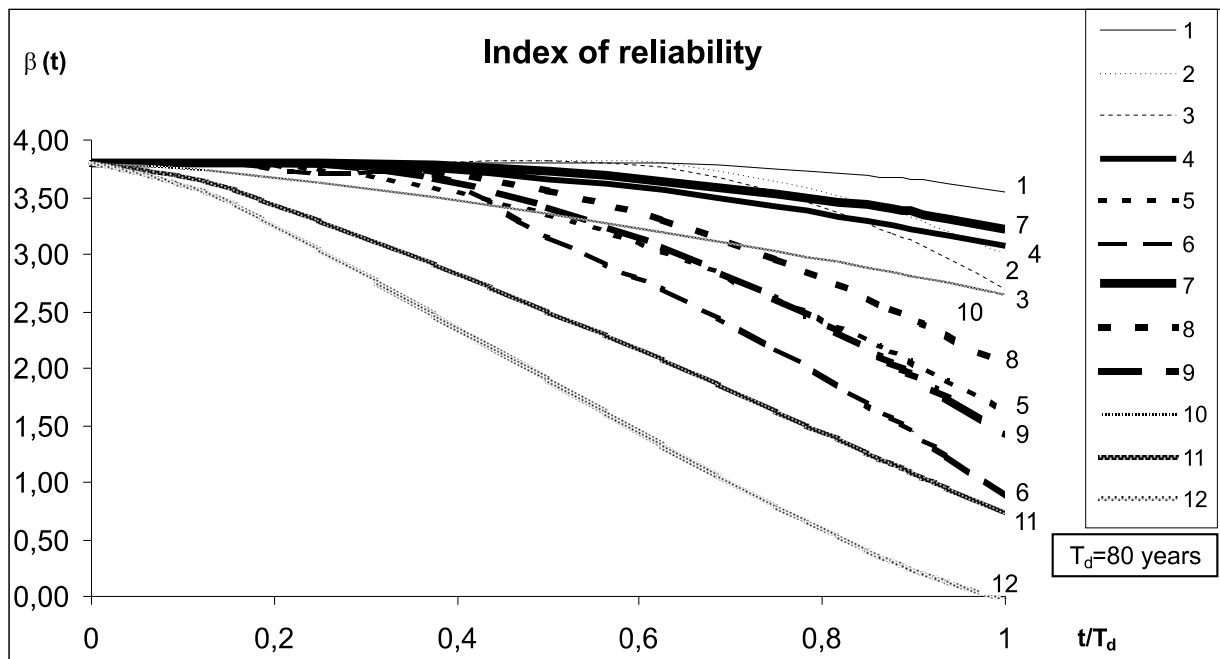

Obr. 6 Časovo závislý index spoľahlivosti  $\beta(t)$  ohýbaného prvku napadnutého koróziou  
Fig. 6 Time dependent reliability index  $\beta(t)$  of bending member under corrosion attack

#### 4. Závery

V prezentovanom príspevku sme sa zaoberali vplyvom korózie na odolnosť a spoľahlivosť ohýbaného železobetónového prvku.

Zmena strednej hodnoty odolnosti  $m_R(t)$  rozhodujúco ovplyvňuje zmenu pravdepodobnosti poruchy. Stredná hodnota odolnosti sa nemení počas pasívneho štádia. Dĺžky uvažovaných pasívnych štádií boli:

- 32,2 rokov ( $D = 2,84 \cdot 10^{-7} \text{ mm}^2 \cdot \text{s}^{-1}$ ),
- 18,9 rokov ( $D = 4,82 \cdot 10^{-7} \text{ mm}^2 \cdot \text{s}^{-1}$ ),
- 21,5 rokov ( $w = 0,170 \text{ year}^{-0,5}$ ),
- 6,3 rokov ( $w = 0,160 \text{ year}^{-0,5}$ ).

Dĺžka pasívneho štádia značne ovplyvňuje strednú hodnotu odolnosti  $m_R(t)$  a pravdepodobnosť poruchy  $P_f(t)$ . Najkratšie pasívne štádium rovné 6,3 rokom zodpovedá veľmi agresívnym podmienkam (primorské krajiny). Z tohoto dôvodu nie sú tieto výsledky (krivka 10, 11, 12 na obr. 4) aplikovateľné v našej krajine.

Hodnoty hustoty prúdovej korózie  $i_{corr}$  a stupňa korózie  $r_{corr}$  významne ovplyvňujú strednú hodnotu odolnosti  $m_R(t)$ . Vyššie hodnoty  $i_{corr}$  a  $r_{corr}$  zodpovedajú väčšiemu úbytku strednej hodnoty odolnosti. Hodnota  $r_{corr}$  je taktiež nereálna pre naše klimatické

#### 4. Conclusions

In this paper, the influence of reinforcement corrosion on the resistance and reliability of concrete element subjected to bending is presented.

The change of mean value of resistance  $R(t)$  affects decisively the change of failure probability. The mean value is not changed during the passive stage. The lengths of the passive stage were:

- 32.2 years ( $D = 2,84 \cdot 10^{-7} \text{ mm}^2 \cdot \text{s}^{-1}$ ),
- 18.9 years ( $D = 4,82 \cdot 10^{-7} \text{ mm}^2 \cdot \text{s}^{-1}$ ),
- 21.5 years ( $w = 0,170 \text{ year}^{-0,5}$ ),
- 6.3 years ( $w = 0,160 \text{ year}^{-0,5}$ ).

The length of the passive stage influences the mean value of resistance  $R(t)$  and the failure probability  $P_f(t)$  to a great degree. The shortest passive stage equals to 6.3 years corresponds to very aggressive conditions (seaside countries). Therefore, the results (curves 10, 11, 12, Fig. 4) are not applicable in our country.

The values of the corrosion current density  $i_{corr}$  and corrosion rate  $r_{corr}$  affect the mean value of resistance  $R(t)$  significantly. The higher value of  $i_{corr}$  and  $r_{corr}$  correspond to a higher decrease of the mean value of resistance. The value of  $r_{corr}$  should be not

prostredie, pretože nakoľko zodpovedá vysoko agresívnym podmienkam – krivky 6,9.

Smerodajná odchýlka odolnosti  $s_R(t)$  značne závisí od smerodajných odchýlok hustoty prúdovej korózie  $i_{corr}$  a stupňa korózie  $r_{corr}$ . Smerodajná odchýlka odolnosti v čase rastie s väčšou smerodajnou odchýlkou  $i_{corr}$  a  $r_{corr}$  (krivky 2, 5, 8, 12, obr. 5).

Pravdepodobnosť poruchy  $P_f(t)$  a index spoľahlivosti  $\beta(t)$  sa významne začínajú meniť po polovici životnosti mosta. Stredná hodnota odolnosti mení najvýraznejšie pravdepodobnosť poruchy. Získaná časová závislosť pravdepodobnosti poruchy prvků umožňuje kvalitnejšie plánovanie údržby mostu a presnejšie stanovenie doby jeho rekonštrukcie.

## Oznámenie

Príspevok bol vypracovaný v rámci výskumu podporovaného grantovou agentúrou VEGA SR (grantová úloha č. 1/7344/20).

applicable in our region (it corresponds to aggressive conditions too – curves 6,9).

The standard deviation of resistance  $R(t)$  depends much on the standard deviation of corrosion current density  $i_{corr}$  and corrosion rate  $r_{corr}$ . The resistance standard deviation is increased in time with a higher standard deviation of  $i_{corr}$  and  $r_{corr}$  (curves 2, 5, 8, 12, fig. 5).

The failure probability  $P_f(t)$  and reliability index  $\beta(t)$  are changed significantly after half of bridge lifetime. The change of the resistance mean value influences failure probability mostly.

The obtained time dependent failure probability of member can be used for planning maintenance and determining the time of its reconstruction.

## Acknowledgements

The research work presented in this paper has been supported by Slovak Grant Agency, Grant No 1/7344/20

## 5. Literatúra – References

- [1] VIČAN, J., KOTEŠ, P.: *New Developments in Bridge Management. Quality and Reliability in Building Industry*. Levoča 1999, p. 325-330
- [2] KOTEŠ, P., VIČAN, J., SLAVÍK, J.: *Influence of reinforcement corrosion on reliability of existing concrete structures*. International Conference "Transcom '2001", Žilina 2001, p. 23-26
- [3] VIČAN, J., SLAVÍK, J., KOTEŠ, P.: *Influence of inspections on reliability of existing bridges*. 19-th international conference "Steel structures and bridges 2000", High Tatras, p. 69-74
- [4] VIČAN, J. a kol.: *Methodology of computing of load-carrying capacity of existing road network bridges*. University of Žilina, 1999
- [5] MRÁZIK, A.: *Reliability theory of steel structures*. VEDA Bratislava 1987 (in Slovak)
- [6] TUUTTI, K.: *Corrosion of Steel in Concrete*. CBI forskning/research, 04. 1982
- [7] ANDRADE, C., SARRIA, J., ALONSO, C.: *Corrosion rate field monitoring of post-tensioned tendons in contact with chlorides*. Conference "Durability of building materials and components, Stockholm, 1996, p. 959-967.
- [8] VAL, D.V., MELCHER, R.E.: *Reliability of deteriorating RC slab bridges*. Journal of structural engineering, December 1997, p. 1638-1644
- [9] THOFT-CHRISTENSEN, P.: *A Reliability Based Expert System for Bridge Maintenance*. Tekno Vision Conference, Denmark, 1992
- [10] MATOUŠEK, M., DROCHYTKA, R.: *Atmospheric corrosion of concrete*. IKAS Prague 1998
- [11] BILČÍK, J.: *Prediction of Service Life with regard to Reinforcement Corrosion*, Slovak Journal of Civil Engineering 2-3, 1994, p. 34-38
- [12] FREY, R.: *Untersuchung der zwanzigjährling Carbonatisierung von Betonen*. Beton 43, 1993, Heft3, p. 116-120
- [13] KALA, Z.: *Approximation and Advanced Numerical Simulation Methods*. II. Conference "Reliability of Structures", Ostrava, 2001, p. 97-100

Róbert Tenzer \*

# GEOPOTENCIÁLNY MODEL ZEME – APROXIMÁCIA TVARU ZEME, METÓDY TESTOVANIA GEOPOTENCIÁLNYCH MODELOV

## GEOPOTENTIAL MODEL OF EARTH – APPROXIMATION OF EARTH SHAPE, GEOPOTENTIAL MODEL TESTING METHODS

*Stokesové geodynamické koeficienty v rozvoji tiažového potenciálu Zeme slúžia na matematicko-fyzikálny popis vonkajšieho tiažového poľa, tvaru a rozmeru Zeme. V článku sú uvedené výsledky testovania presnosti geopotenciálneho modelu EGM96 na území Slovenska.*

*Stokes' geodynamic parameters in the expansion of the gravity potential of the Earth serve for a mathematical and physical description of an outer gravity field of the Earth, the shape and the size of the Earth. In this article, the results from testing of an accuracy of the geopotential model EGM 96 at the territory of Slovakia are published.*

### 1. Úvod – historické pozadie určovania tvaru Zeme

Meškanie kyvadlových hodín astronóma Richera pri premiestnení z Paríža do Cayenne (pri rovníku) vysvetlil I. Newton zmenšením gravitačnej sily v dôsledku sploštenia Zeme na póloch. Na základe všeobecnej teórie gravitácie (*Philosophiae naturalis principia mathematica*, 1687) za predpokladu, že Zem je homogénne

teleso, určil Newton jej sploštenie  $f = \frac{a-b}{a} = \frac{1}{230}$ , kde  $a$ ,  $b$  sú veľkosti rovníkovej a pólovej poloosi.

Neskôr Ch. Huygens predpokladal, že každá častica Zeme je priťahovaná len do jej stredu (celá hmotnosť je sústredená v ťažisku). Na základe svojho modelu vypočítal sploštenie  $f = 1/578$ .

Tento nesúhlas medzi oboma výsledkami objasnil A. Clairaut (*Theorie de la figure de la Terre*, 1743). Uvažoval sféroid, zložený z koncentrických vrstiev, ktorých hustota rastie ku stredu Zeme a odvodil vzťahy známe ako Clairautov teorém, vyjadrujúci vzájomný vzťah medzi geometrickými a fyzikálnymi parametrami Zeme

$$f = \frac{5}{2}q - \beta = \frac{5}{2} \frac{a^2 \omega^2}{GM a^{-1}} - \frac{g_p - g_e}{g_e} = \frac{5}{2} \frac{a^3 \omega^2}{GM} - \frac{g_p - g_e}{g_e} = \frac{5}{2} \frac{a \omega^2}{g_e} - \frac{g_p - g_e}{g_e}, q = \frac{a^3 \omega^2}{GM},$$

kde  $g_p$ ,  $g_e$  sú tiažové zrýchlenie na póloch a rovníku,  $\omega$  je uhlová rýchlosť rotácie Zeme.

Na základe spracovania údajov o dráhach družíc, altimetrových údajov topografie povrchu svetového oceánu a údajov z tiažových meraní je možné v súčasnosti pomerne podrobne defi-

### 1. Introduction – historical background of estimation of Earth's shape

The delay of astronomer Richer's pendulum clock during the relocation from Paris to Cayenne (near the equator) was explained by I. Newton as a decrease in the gravitational force resulting from flattening of the Earth at the poles. Based on the common theory of gravitation (*Philosophiae naturalis principia mathematica*, 1687) and providing the Earth to be a homogeneous body,

Newton estimated the Earth's flattening as  $f = \frac{a-b}{a} = \frac{1}{230}$ ,

where  $a$ ,  $b$  are the sizes of the equatorial axis and the pole axis, respectively.

Later on, Ch. Huygens assumed every Earth's element to be forced just into the earth's center (entire mass is centered inside the center of gravity). Based on his model, he calculated the flattening as  $f = 1/578$ .

The contradiction between both findings was explained by A. Clairaut (*Theorie de la figure de la Terre*, 1743). He considered a spheroid composed of concentric layers whose density increased towards the Earth's center, and has derived forms known as Clairaut's theorem, expressing the correlation between the geometric and the physical parameters of the Earth

where  $g_p$ ,  $g_e$  are the gravity acceleration on the poles and on the equator,  $\omega$  is the angular velocity of the Earth's rotation.

Nowadays, it is possible to define the shape and the size of the Earth and the gravity field outer the Earth with quite high accuracy based on processing of the satellite tracking data, the altim-

\* Ing. Róbert Tenzer, PhD.

Department of Geodetic Survey, Faculty of Civil Engineering, University of Žilina, Komenského 52, SK-01001 Žilina

novaf tvar a rozmer Zeme, ako aj popisaf tiažové pole v okolí Zeme.

V spolupráci NIMA (National Imagery and Mapping Agency) a NASA GSFC (National Aeronautics and Space Administration Goddard Space Flight Center) bol vytvorený Gravitačný model Zeme EGM 96 (Earth's gravity model 1996) [10].

Pracovná skupina WG GGT (Working Group Global Geodesy Topics) spolupracuje na testovaní presnosti určenia EGM 96, pričom pre tento účel bola vytvorená metodológia testovania [1] a vytvorená testovacia sieť na území oceánov a kontinentov [2], [3], [4].

## 2. Aproximácia tvaru Zeme - normálny hladinový sféroid a elipsoid

Tiažový potenciál  $W(\rho, \Phi, \Lambda)$  vyjadruje jeho rozvoj do radu sférických funkcií ( $n, k \rightarrow \infty$ )

$$W(\rho, \Phi, \Lambda) = \frac{GM}{\rho} \left[ 1 + \sum_{n=2}^{\infty} \sum_{k=0}^n \left( \frac{a_o}{\rho} \right)^n (J_n^{(k)} \cos k\Lambda + S_n^{(k)} \sin k\Lambda) P_n^{(k)}(\sin\Phi) \right] + \frac{1}{2} \rho^2 \omega^2 \cos^2\Phi =$$

$$= \frac{GM}{\rho} \left\{ 1 + \sum_{n=2}^{\infty} \sum_{k=0}^n \left( \frac{a_o}{\rho} \right)^n (J_n^{(k)} \cos k\Lambda + S_n^{(k)} \sin k\Lambda) P_n^{(k)}(\sin\Phi) + \frac{1}{3} \frac{\rho^3 \omega^2}{GM} [1 - P_n^{(0)}(\sin\Phi)] \right\}, \quad (2.1)$$

kde  $\rho$  je geocentrický rádius vektor bodu  $P$ ,  $\Phi, \Lambda$  sú jeho geocentrické súradnice,  $a_o$  je ľubovoľný dĺžkový parameter (spravidla veľká poloos hladinového rotačného elipsoidu),  $J_n^{(k)}, S_n^{(k)}$  sú Stokesove geodynamické parametre stupňa  $n$  a rádu  $k$  [5]

$$\left. \begin{matrix} J_n^{(k)} \\ S_n^{(k)} \end{matrix} \right\} = \frac{(2 - \delta_{0,k}) (n-k)!}{M a_o^n (n+k)!} \int_M \rho'^n P_n^{(k)}(\sin\Phi') \begin{cases} \cos k\Lambda' \\ \sin k\Lambda' \end{cases} dm, \quad \delta_{0,k} = \begin{cases} 1, & k=0, \\ 0, & k \neq 0, \end{cases} \quad (2.2)$$

$M$  je hmotnosť Zeme,  $dm(\rho', \Phi', \Lambda')$  je hmotný element Zeme,  $P_n^{(k)}(\sin\Phi)$  sú Legendreove pridružené funkcie [9], [5]

$$P_n^{(k)}(\sin\Phi) = \frac{1}{2^n n!} \cos^k \Phi \frac{d^{n+k}}{d(\sin\Phi)^{n+k}} [-\cos^{2n}\Phi] = \frac{(2n)!}{2^n n! (n-k)!} \cos^k \Phi \left[ \sin^{n-k} \Phi - \frac{(n-k)(n-k-1)}{2(2n-1)} \sin^{n-k-2} \Phi + \right.$$

$$\left. + \frac{(n-k)(n-k-1)(n-k-2)(n-k-3)}{2 \cdot 4(2n-1)(2n-3)} \sin^{n-k-4} \Phi - \dots \right]. \quad (2.3)$$

Obmedzenie stupňa rozvoja tiažového potenciálu na určitý počet členov popisuje normálny tiažový potenciál a hladinová plocha ním definovaná je normálny hladinový sféroid. Pri splnení

podmienok  $J_n^{(0)} = \frac{A-C}{M a_o^2}, J_1^{(0)} = J_1^{(1)} = S_1^{(1)} = 0$  a rozvojom

stupňa  $n = \bar{n} = 2, k = 0$ , je definovaný tiažový potenciál Clairautovho sféroidu

$$U = \frac{GM}{\rho} \left\{ 1 + \left( \frac{a_o}{\rho} \right)^2 J_2^{(0)} P_2^{(0)}(\sin\Phi) + \frac{1}{3} q \left( \frac{a_o}{\rho} \right)^{-3} [1 - P_2^{(0)}(\sin\Phi)] \right\}. \quad (2.4)$$

ter data of ocean surface topography and data obtained from the Earth's gravity measurements.

NIMA (National Imagery and Mapping Agency) and NASA GSFC (National Aeronautics and Space Administration Goddard Space Flight Center) have participated to develop the gravity model of the Earth EGM 96 (Earth's gravity model 1996) [10].

Working group WG GGT (Working Group Global Geodesy Topics) collaborates on testing the accuracy estimation of EGM 96. For this purpose the testing methodology [1] and the testing network over oceans and continents [2], [3], [4] have been created.

## 2. Approximation of Earth's shape - normal level spheroid and ellipsoid

The gravity potential  $W(\rho, \Phi, \Lambda)$  expresses its expansion to the series of spherical functions ( $n, k \rightarrow \infty$ )

where  $\rho$  is the geocentric radius-vector of the point  $P$ ,  $\Phi, \Lambda$  are its geocentric coordinates,  $a_o$  is an arbitrary parameter of length (usually the semi-major axis of the level rotation ellipsoid),  $J_n^{(k)}, S_n^{(k)}$  are Stokes' geodynamic parameters of degree  $n$  and order  $k$  [5]

$M$  is the weight of the Earth,  $dm(\rho', \Phi', \Lambda')$  is the mass element of the Earth,  $P_n^{(k)}(\sin\Phi)$  are Legendre's associated functions [9], [5]

The limitation of a degree of the expansion of the gravity potential to certain number of coefficients is described by the normal gravity potential and the level surface defined by it is the

normal leveling spheroid. Under the condition  $J_n^{(0)} = \frac{A-C}{M a_o^2}, J_1^{(0)} =$

$J_1^{(1)} = S_1^{(1)} = 0$  and by setting the degree of expansion  $n = \bar{n} = 2, k = 0$ , the geopotential of Clairaut's spheroid is defined as

Geoid a normálny hladinový sféroid sú idealizované fyzikálne telesá nevhodné na matematické vyjadrenie priestorových vzťahov (Clairautov sféroid je plocha 14. stupňa [8]). Túto požiadavku spĺňa až zemský rotačný elipsoid, ktorý je matematickou aproximáciou tvaru Zeme. Plocha normálneho hladinového sféroidu je blízka ploche zemského referenčného elipsoidu, preto je možné sféroid nahradiť elipsoidom. Z rovnice rotačného elipsoidu vyplýva pre geocentrický rádius vektor  $\rho$  približný vzťah

$$\begin{aligned} (X^2 + Y^2)a^{-2} + Z^2a^{-2}(1 - e^2)^{-1} - 1 &= a^{-2}[\rho^2 \cos^2\Phi \cos^2\Lambda + \rho^2 \cos^2\Phi \sin^2\Lambda] + a^{-2}\rho^2 \sin^2\Phi(1 - e^2)^{-1} - 1 = \\ &= \rho^2 \cos^2\Phi(1 - e^2) + \rho^2 \sin^2\Phi - a^2(1 - e^2) \Rightarrow \rho = \frac{a\sqrt{1 - e^2}}{\sqrt{1 - e^2 \cos^2\Phi}} \cong a\sqrt{1 - e^2} \left(1 + \frac{1}{2} e^2 \cos^2\Phi\right) = \\ &= a \left\{ 1 - \frac{1}{2} e^2 + \frac{1}{2} e^2 \left[ \frac{2}{3} - \frac{2}{3} P_2^{(0)}(\sin\Phi) \right] \right\} = a \left[ 1 - \frac{1}{6} e^2 - \frac{1}{3} P_2^{(0)}(\sin\Phi) \right], \end{aligned} \quad (2.5)$$

a z rozvoja normálneho tiažového potenciálu Clairautovho sféroidu vyplýva pre jeho rádius vektor

$$\rho = R_o \left\{ 1 + \frac{1}{3} q \left(\frac{a_o}{\rho}\right)^{-3} + \left[ \left(\frac{a_o}{\rho}\right)^2 J_2^{(0)} - \frac{1}{3} q \left(\frac{a_o}{\rho}\right)^{-3} \right] P_2^{(0)}(\sin\Phi) \right\}, \quad R_o = \frac{GM}{U_o}, \quad (2.6)$$

kde  $R_o$  je dĺžkový rozmerový faktor.

Z porovnania rovníc rádius vektorov elipsoidu (2.4) a sféroidu (2.5) vyplýva Clairautova rovnica

$$R_o \left( J_2^{(0)} - \frac{1}{3} q \right) = \frac{a e^2}{3} \Rightarrow J_2^{(0)} - \frac{1}{3} q = \frac{a e^2}{3R_o} \Rightarrow J_2^{(0)} - \frac{1}{3} q = \frac{2}{3} f \Rightarrow f = -\frac{3}{2} J_2^{(0)} + \frac{1}{2} q, \quad (2.7)$$

vyjadrujúca vzťah medzi geometrickou veličinou  $f$  a fyzikálnymi veličinami sféroidu  $J_2^{(0)}$ ,  $q$  s ohľadom na prijaté zjednodušenia

$$R_o \cong a, f = \frac{a - b}{a} = 1 - \sqrt{1 - e^2} \cong \frac{1}{2} e^2, \rho = a_o.$$

*Poznámka: Helmert doplnil rozvoj potenciálu hladinového sféroidu zonálnym členom stupňa  $n = 4$  a odvodil tiažové zrýchlenie na povrchu normálneho hladinového elipsoidu (aproximujúceho sféroid), ktoré sa používa napriek jeho zastaranosti aj v súčasnosti v prípadoch geodetických základov na Krasovského referenčnom elipsoide, pretože oba elipsoidy majú prakticky rovnaké hodnoty sploštenia.*

Normálny tiažový potenciál  $U$  a zrýchlenie  $\gamma$  normálneho hladinového rotačného elipsoidu vyjadrujú rovnice [8]

$$U = \frac{GM}{ae} \arctan e' + \frac{1}{3} \omega^2 a^2, \quad (2.8)$$

$$\gamma = \frac{GM}{a\sqrt{a^2 \sin^2\beta + b^2 \cos^2\beta}} \left[ 1 + \frac{\omega^2 a^3 e}{GM} \frac{p'_o}{p_o} \left( \frac{1}{2} \sin^2\beta - \frac{1}{6} \right) - \frac{\omega^2 a^2 b}{GM} \cos^2\beta \right], \quad (2.9)$$

Geoid and the normal level spheroid are only idealized physical bodies, which are not suitable for mathematical expression of spatial relations (Clairaut's spheroid is a surface of 14<sup>th</sup> degree [8]). Just using the earth's rotation ellipsoid, which is the mathematical approximation of the Earth's shape, can satisfy this condition. The surface of the normal level spheroid is similar to the surface of the earth's reference ellipsoid therefore the spheroid can be replaced by the ellipsoid. For the geocentric radius-vector  $\rho$  following form can be derived from an equation for the rotation ellipsoid

The radius vector can be derived from an expansion of the normal geopotential of Clairaut's spheroid

where  $R_o$  is the size factor of length.

The comparison between the equations for radius vector of ellipsoid (2.4) and spheroid (2.5) yields the Clairaut's equation

which expresses the relation between the geometric parameter  $f$  and the physical parameters of spheroid  $J_2^{(0)}$ ,  $q$ , considering adopted

$$\text{simplifications } R_o \cong a, f = \frac{a - b}{a} = 1 - \sqrt{1 - e^2} \cong \frac{1}{2} e^2, \rho = a_o.$$

*Note: Helmert added a zonal member of degree  $n = 4$  into expansion of the potential level spheroid and derived a gravity acceleration on a surface of the normal level ellipsoid (that approximates spheroid), which is still used in causes of geodetic bases on Krasovsky's reference ellipsoid, as both ellipsoids have practically equal value of flattening.*

The normal gravity potential  $U$  and the acceleration  $\gamma$  of the normal level rotation ellipsoid are expressed by equations [8]

kde

$$p'_o = 3(1 + e'^{-2})(1 - e'^{-1} \arctan e') - 1, \quad p_o = \frac{1}{2} \left[ \left( 1 + \frac{1}{3} e'^{-2} \right) \arctan e' - 3e'^{-1} \right], \quad \tan \beta = \frac{b}{a} \tan B.$$

where

### 3. Teoretický princíp testovania geopotenciálnych modelov

Na určenie presnosti geopotenciálneho modelu je potrebné poznať geocentrické súradnice a Molodenského normálne výšky  $h$  na bodoch testovacej siete. Použitie ortometrických výšok  $h'$  a geoidu v oblastiach kontinentov nie je vhodné z dôvodu použitia hypotézy o rozložení hustoty hmoty medzi geoidom a zemským povrchom. Naproti tomu teória Molodenského normálnych výšok nepredpokladá nijaké hypotézy [12].

Teoreticky je skutočný tiažový potenciál  $W(\rho, \Phi, \Lambda)$  v bode  $P$  na zemskom povrchu rovný normálnemu tiažovému potenciálu v bode  $P_o$  na teluroide (obr. 1)

$$W(\rho, \Phi, \Lambda) = U(\Phi_o, h). \quad (3.1)$$

Vzdialenosť medzi teluroidom a elipsoidom je normálna výška  $h$  a vzdialenosť medzi zemským povrchom a teluroidom je výšková anomália  $\zeta$ .

Normálny tiažový potenciál  $U(\Phi_o, h, GM, a_o, \omega, f)$  na teluroide je definovaný ako funkcia geocentrickej gravitačnej konštanty  $GM$ , strednej uhlovej rýchlosti rotácie Zeme  $\omega$ , veľkosti hlavnej poloosi  $a_o$  a sploštenia  $f$  hladinového rotačného elipsoidu vzťahom [8]

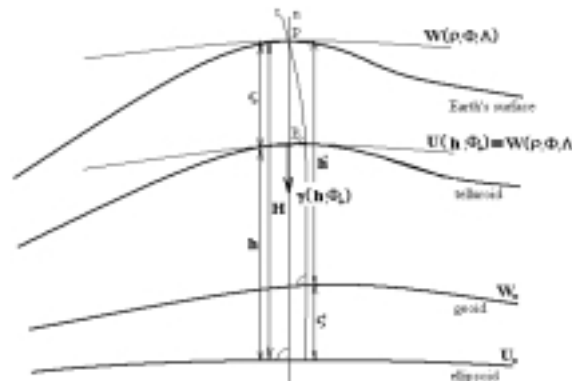

Obr. 1. Teória výšok, normálna výška a ortometrická výška  $h'$   
Fig. 1. Theory of heights, normal height and orthometric height  $h'$

### 3. Theoretic principle of geopotential model testing

The accuracy estimate requires the geocentric coordinates and Molodensky's normal heights  $h$  at the points of testing network. The orthometric heights  $h'$  and geoid over continents are not suitable for using because of hypothesis about distribution of density of mass between the geoid and the earth's surface. On the other hand, the Molodensky's normal heights theory does not assume any hypothesis [12].

Theoretically, the actual gravity potential  $W(\rho, \Phi, \Lambda)$  at the point  $P$  on the earth's surface is equal to the normal potential at the point  $P_o$  on the telluroid (Fig. 1)

$$W(\rho, \Phi, \Lambda) = U(\Phi_o, h). \quad (3.1)$$

The distance between the telluroid and ellipsoid is the normal height  $h$  and the distance between the earth's surface and the telluroid is the height anomaly  $\zeta$ .

The normal gravity potential  $U(\Phi_o, h, GM, a_o, \omega, f)$  on the telluroid is defined as a function of the geocentric gravitational constant  $GM$ , the mean angular velocity of the Earth's rotation  $\omega$ , the size of the semi-major axis  $a_o$  and the flattening  $f$  of the level rotation ellipsoid [8]

$$\begin{aligned} U(\rho_o, \Phi_o) &= \frac{GM}{\rho_o} \left[ 1 - \sum_{n=1}^{\infty} (-1)^{n+1} \frac{3e^{2n}}{(2n+1)(2n+3)} \left( 1 - n + 5n \frac{J_2^{(0)}}{e^2} \right) \left( \frac{a_o}{\rho_o} \right)^{2n} P_{2n}^{(0)}(\sin \Phi_o) \right] + \frac{1}{2} \omega^2 \rho_o^2 \cos^2 \Phi_o = \\ &= \frac{GM}{\rho_o} \left[ 1 - \sum_{n=1}^{\infty} \left( \frac{a_o}{\rho_o} \right)^{2n} \frac{\sin \Phi_o}{n!} \frac{d^n}{d(\sin^2 \Phi_o)^n} [-\sin^{2n-1} \Phi_o \cos^{2n} \Phi_o] P_{2n}^{(0)}(\sin \Phi_o) \right] + \frac{1}{2} \omega^2 \rho_o^2 \cos^2 \Phi_o, \end{aligned} \quad (3.2)$$

alebo v uzavretom tvare pomocou krivočiarych súradníc  $u, v, w$  [7] | or in closed form using curvilinear coordinates  $u, v, w$  [7]

$$\begin{aligned} U(\Phi_o, h) &= U(u, v, w) = \frac{GM}{ae} \arctan^{-1} \sinh w + \frac{1}{3} \omega^2 a^2 e^2 \cosh^2 w + P_2^{(0)}(\cos u) \times \\ &\times \left\{ \frac{1}{3} \frac{\omega^2 a^2}{P} [(3 \sinh^2 w + 1) \arctan^{-1} \sinh w - 3 \sinh w] - \frac{1}{3} \omega^2 a^2 e^2 \cosh^2 w \right\} = \\ &= \frac{GM}{ae} \left\{ \arctan^{-1} \sinh w + \frac{1}{3} qe [(3 \sinh^2 w + 1) \arctan^{-1} \sinh w - 3 \sinh w] \times \right. \\ &\times \left. \left[ \frac{3 - 2e^2}{e^2} \arctan \frac{e}{\sqrt{1-e^2}} - 3 \frac{\sqrt{1-e^2}}{e} \right]^{-1} e P_2^{(0)}(\cos u) + \frac{1}{3} qe^3 \cosh^2 w [1 - P_2^{(0)}(\cos u)] \right\}, \end{aligned} \quad (3.3)$$

kde

$$P = \frac{3 - 2e^2}{e^2} \arctan \frac{e}{1-f} - 3 \frac{1-f}{e}, \quad P_2^{(0)}(\cos u) = \frac{3}{2} \cos^2 u - \frac{1}{2}, \quad e^2 = 2f - f^2 = \frac{a^2 - b^2}{a^2}, \quad f = \frac{a-b}{a}, \quad q = \frac{\omega^2 a_o^3}{GM}. \quad (3.4)$$

Vzájomný vzťah medzi  $u, v, w$  a  $X, Y, Z$ , resp. geodetickými zemepisnými súradnicami  $B, L, H$  vyjadrujú rovnice [6], [5]

$$\begin{aligned} X &= ae \cosh w \sin u \cos v = (N + H) \cos B \cos L, \\ Y &= ae \cosh w \sin u \sin v = (N + H) \cos B \sin L, \\ Z &= ae \sinh w \cos u = [N(1 - e^2 + H)] \sin B, \end{aligned} \quad (3.5)$$

$$u = \arccos \frac{Z}{ae \sinh w}, \quad v = \arctan \frac{Y}{X}, \quad w = \log(\cosh w + \sinh w), \quad \cosh^2 w = \sqrt{1 + \sinh^2 w},$$

$$\sinh w = \frac{\sqrt{\rho^2 - a^2 e^2} + \sqrt{(\rho^2 - a^2 e^2)^2 + 4a^2 e^2 Z^2}}{2a^2 e^2}, \quad \rho^2 = X^2 + Y^2 + Z^2, \quad N = \frac{a}{\sqrt{1 - e^2 \sin^2 B}},$$

$$\tan \Phi = (1 - e^2) \tan B = \frac{b^2}{a^2} \tan B. \quad (3.6)$$

Na testovanie geopotenciálneho modelu na území Slovenska je potrebné vyjadriť tiažový potenciál  $W(\rho, \Phi, \Lambda)$  v slapovom systéme MEAN [13]

The testing of the geopotential model over the territory of Slovakia requires expressing the gravity potential  $W(\rho, \Phi, \Lambda)$  in the mean tidal reference system MEAN [13]

$$W = \frac{GM}{\rho} \left\{ 1 + \sum_{n=2}^{\bar{n}} \sum_{k=0}^n \left( \frac{a_o}{\rho} \right)^n (J_n^{(k)} \cos k \Lambda + S_n^{(k)} \sin k \Lambda) P_n^{(k)}(\sin \Phi) + \frac{1}{3} \left( \frac{a_o}{\rho} \right)^{-3} q [1 - P_2^{(0)}(\sin \Phi)] + \right.$$

$$\left. + (1 + k_s - h_s) \left[ \frac{GM_L}{GM} \left( \frac{\rho}{\rho_L} \right)^3 P_2^{(0)}(\sin \delta_L) P_2^{(0)}(\sin \Phi) + \frac{GM_S}{GM} \left( \frac{\rho}{\rho_S} \right)^3 P_2^{(0)}(\sin \delta_S) P_2^{(0)}(\sin \Phi) \right] \right\}, \quad (3.7)$$

kde  $\delta_S, \delta_L, \rho_S, \rho_L$  sú geocentrické deklinácie a geocentrické rádius vektory slapovtorných telies (Slnko a Mesiac);  $GM_L, GM_S$  sú selenocentrická a heliocentrická gravitačná konštanta,  $k_s, h_s$  sú sekulárne Loveho čísla [11], ktoré vyjadrujú plastickú reakciu pružnej Zeme na gravitačné pôsobenie Mesiaca a Slnka,  $\bar{n}$  je maximálny stupeň rozvoja potenciálu.

where  $\delta_S, \delta_L, \rho_S, \rho_L$  are the geocentric declinations and the geocentric radius-vectors of the Sun and the Moon;  $GM_L, GM_S$  are the selenocentric gravitational constant and the heliocentric gravitational constant, respectively,  $k_s, h_s$  are the secular Love numbers [11], which describe the elastic response of the Earth to the gravitational effect of the Sun and the Moon,  $\bar{n}$  is the maximum degree of expansion of the potential.

Presnosť určenia geopotenciálneho modelu je možné vyjadriť ako funkciu rozdielu medzi anomáliou výšky vypočítanou z modelu a anomáliou výšky určenej z GPS a nivelácie

The accuracy estimation of the geopotential model can be expressed as a function of difference between the height anomaly computed from the geopotential model and the height anomaly determined from GPS and leveling.

$$\delta_\zeta = H - h - \left[ \frac{W(\rho, \Phi, \Lambda) - U(\rho, \Phi)}{\gamma(\rho, \Phi)} \right], \quad (3.8)$$

kde  $H$  je elipsoidická výška bodu  $P$ ;  $U(\rho, \Phi)$ ,  $\gamma(\rho, \Phi)$  sú normálny potenciál a normálne tiažové zrýchlenie v bode  $P$  na zemskom povrchu v tvare [8]

$$\delta_\zeta = H - h - \left[ \frac{W(\rho, \Phi, \Lambda) - U(\rho, \Phi)}{\gamma(\rho, \Phi)} \right], \quad (3.8)$$

where  $H$  is the ellipsoidal height of the point  $P$ ;  $U(\rho, \Phi)$ ,  $\gamma(\rho, \Phi)$  are the normal potential and the normal gravity acceleration at point  $P$  on the earth's surface in form of [8]

$$\gamma(\rho, \Phi) = \sqrt{\left[ \frac{\partial U(\rho, \Phi)}{\partial \rho} \right]^2 + \frac{1}{\rho^2} \left[ \frac{\partial U(\rho, \Phi)}{\partial \Phi} \right]^2} = \frac{GM}{\rho^2} \sum_{i=0}^{\infty} (2n+1) \left( \frac{a_o}{\rho} \right)^{2n} J_{2n}^{(0)} P_{2n}^{(0)}(\sin \Phi), \quad (3.9)$$

alebo [6]

or [6]

$$\gamma(u, w) = \sqrt{\left( -\frac{1}{h_w} \frac{\partial U}{\partial w} \right)^2 + \left( \frac{1}{h_u} \frac{\partial U}{\partial u} \right)^2}, \quad (3.10)$$

$$\frac{\partial U}{\partial u} = \frac{1}{2} \omega^2 a^2 e^2 \cos h^2 w \sin^2 u - \frac{1}{2} \frac{\omega^2 a^2}{P} [(3 \sin h^2 w + 1) \arctan \sin h w - 3 \sin h w] \sin^2 u,$$

$$\frac{\partial U}{\partial v} = 0,$$

$$\frac{\partial U}{\partial w} = -\frac{GM}{ae \cosh w} + \frac{1}{2} \omega^2 a^2 e^2 \sin^2 u \sinh^2 w + \frac{1}{3} \frac{\omega^2 a^2}{P} [3 \sin h^2 w \arctan \sin h w - 2 \frac{\sin h^2 w}{\cosh w} - 4 \cosh w] P_2^{(0)}(\cos u),$$

$$h_u^2 = h_w^2 = a^2 e^2 (\cosh^2 w - \sin^2 u), \quad P = \frac{3 - 2e^2}{e^2} \arctg \frac{e}{1 - f} - 3 \frac{1 - f}{e},$$

$$\begin{aligned} \gamma(u, w) = & \sqrt{\frac{1}{a^2 e^2 (\cosh^2 w - \sin^2 u)}} \left\{ \left( \frac{GM}{ae \cosh w} \right)^2 + \frac{1}{4} \omega^4 a^4 e^4 (\sin^4 u \sinh^2 2w + \sin^2 2u \cosh^4 w) + \right. \\ & + \frac{1}{9} \frac{\omega^4 a^4}{P^2} \left[ 3 \sinh 2w \arctan \sin h w - 2 \frac{\sinh^2 w}{\cosh w} - 4 \cosh w \right]^2 [P_2^{(0)}(\cos u)] + \\ & \left. + \frac{1}{4} \frac{\omega^4 a^4}{P^2} [(3 \sin h^2 w + 1) \arctan \sin h w - 3 \sin h w] 2 \sin^2 2u \right\}^{\frac{1}{2}}. \end{aligned} \quad (3.11)$$

#### 4. Presnosť určenia geopotenciálneho modelu EGM 96 na území Slovenska

Presnosť určenia geopotenciálneho modelu EGM 96 bola testovaná na 55 bodoch, ktorých predbežné výsledky sú zo spoločného spracovania kampaní SGN 93, 95, 98, 99, CEGRN 94, 95, 96, 97 a TATRY 98, 99 [11] a pripojenia do ITRF97 postupom uvedeným v [10].

Tiažový potenciál  $W(\rho, \Phi, \Lambda)$  na zemskom povrchu je rovný normálnemu potenciálu  $U(\Phi_o, h)$  na teluroide iba teoreticky.

Rozdiel

$$\delta W = W(\rho, \Phi, \Lambda) - U(\Phi_o, h) \quad (4.1)$$

definuje nepresnosť určenia geopotenciálneho modelu za predpokladu, že chyby v určení výšok môžeme zanedbať.

Obr. 2 vyjadruje rozdiely  $\delta W = W_{EGM 96} - U(P_o)$  medzi tiažovým potenciálom  $W_{EGM 96}$  vypočítanom z modelu EGM 96 a normálnym potenciálom na teluroide  $U(P_o)$  získaného z GPS a nivelácie.

V obr. 5 sú vyjadrené rozdiely medzi anomáliami výšok  $\zeta_{EGM 96}$  vypočítaných z geopotenciálneho modelu EGM 96 a anomáliami výšok  $\zeta_{H-h}$  určených z GPS a nivelácie.

#### 4. Accuracy estimation of geopotential model EGM 96 at territory of Slovakia

The accuracy estimation of the geopotential model EGM 96 was tested at 55 points. The estimations can be obtained from a common processing of the campaigns SGN 93, 95, 98, 99, CEGRN 94, 95, 96, 97 and TATRY 98, 99 [11] and connection into ITRF97 according to the technique described in [10].

The gravity potential  $W(\rho, \Phi, \Lambda)$  on the earth's surface is equal to the normal potential  $U(\Phi_o, h)$  on the telluroid only theoretically.

The difference

$$\delta W = W(\rho, \Phi, \Lambda) - U(\Phi_o, h) \quad (4.1)$$

defines the inaccuracy in the geopotential model under assumption that errors of heights estimation can be neglected.

Figure 2 shows the differences  $\delta W = W_{EGM 96} - U(P_o)$  between the gravity potential  $W_{EGM 96}$  computed from EGM 96 model and the normal potential on the telluroid  $U(P_o)$  obtained from GPS and leveling.

Figure 5 shows the differences between height anomalies  $\zeta_{EGM 96}$  computed from EGM 96 model and height anomalies  $\zeta_{H-h}$  determined from GPS and leveling.

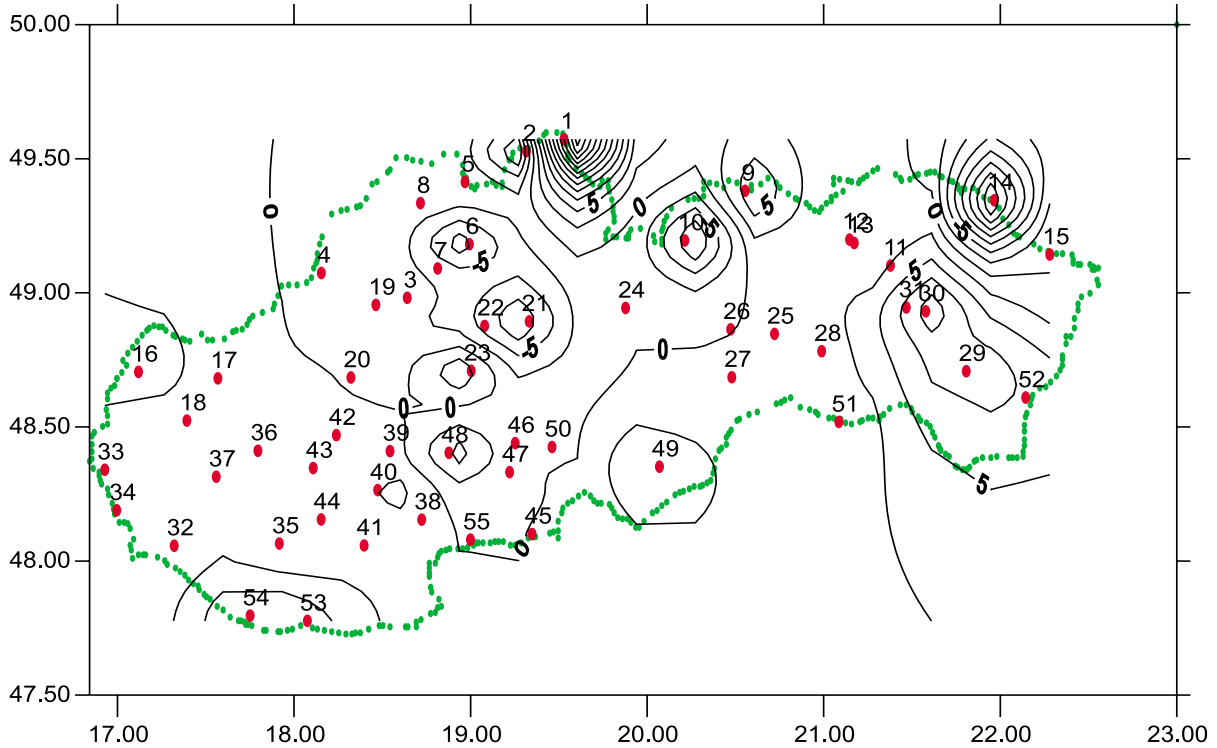

Obr. 2. Rozdiely medzi tiažovým potenciálom  $W_{EGM\ 96}$  vypočítaným z EGM 96 a normálnym potenciálom  $U(P_0)$  určeným z GPS a nivelácie [ $m^2 \cdot s^{-2}$ ]  
Fig. 2. Differences between gravity potential  $W_{EGM\ 96}$  computed from EGM 96 and normal potential  $U(P_0)$  obtained from GPS and leveling [ $m^2 \cdot s^{-2}$ ]

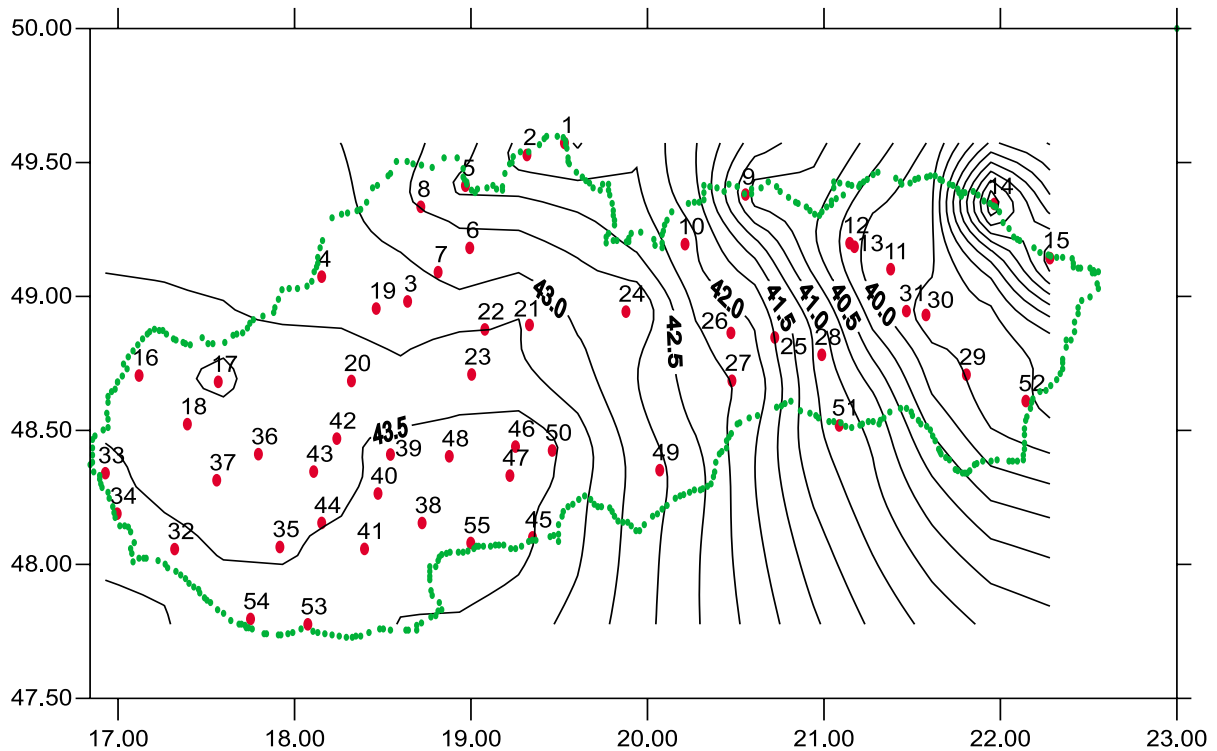

Obr. 3. Anomálie výšok  $\zeta_{H-h}$  určené z GPS a nivelácie [m]  
Fig. 3. Height anomalies  $\zeta_{H-h}$  determined from GPS and leveling [m]

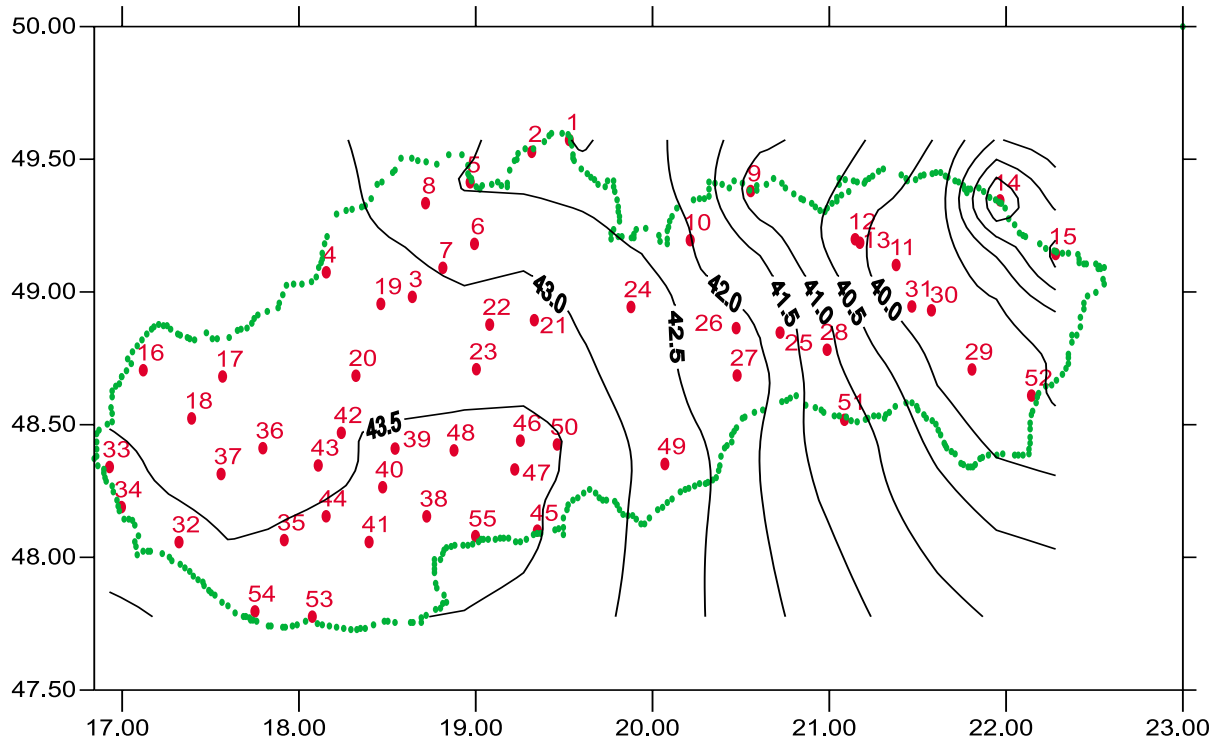

Obr. 4. Anomálie výšok  $\zeta_{EGM\ 96}$  vypočítané z EGM 96 [m]  
Fig. 4. Height anomalies  $\zeta_{EGM\ 96}$  computed from EGM 96 [m]

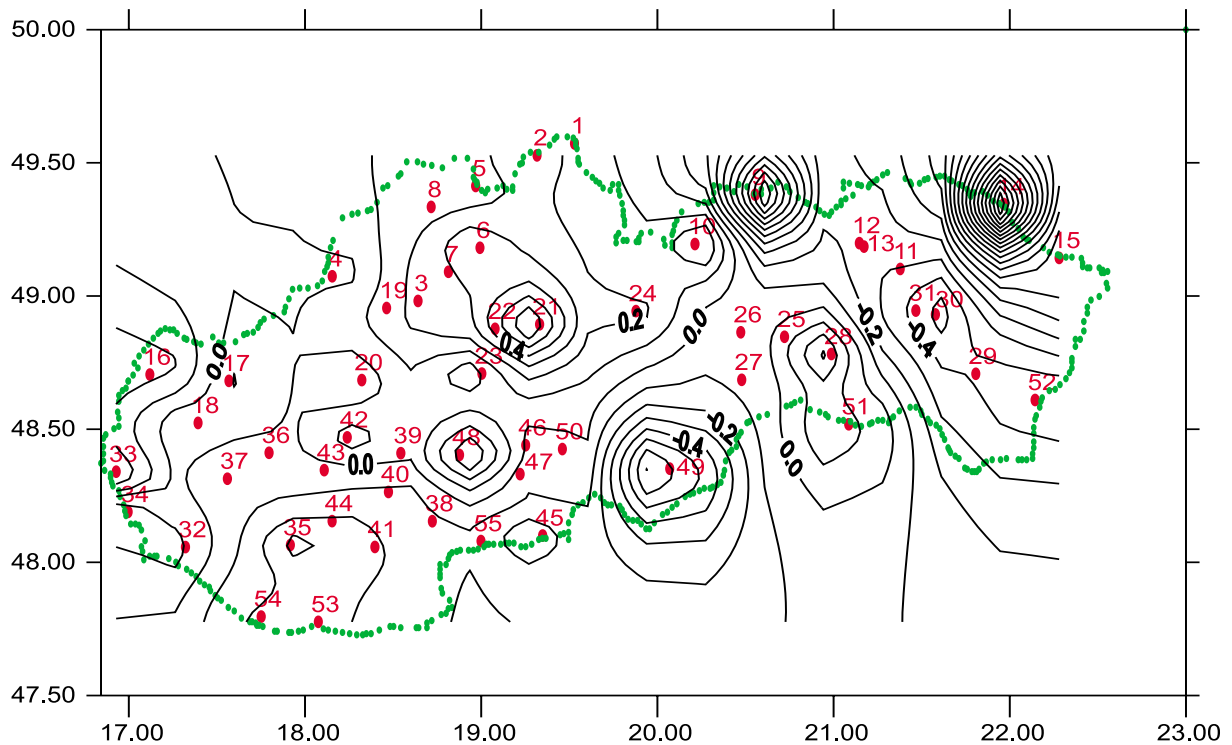

Obr. 5. Rozdiely  $\delta\zeta = \zeta_{H-h} - \zeta_{EGM\ 96}$  medzi anomáliami výšok vypočítaných z EGM 96 a určených z GPS a nivelácie [m]  
Fig. 5. Differences  $\delta\zeta = \zeta_{H-h} - \zeta_{EGM\ 96}$  between height anomalies computed from EGM 96 and obtained from GPS and leveling [m]

## 5. Záver

Nepresnosť určenia geopotenciálneho modelu EGM 96 na území Slovenska vyjadrujú maximálne rozdiely tiažového potenciálu  $|\delta W| = 20 \text{ m}^2\text{s}^{-2}$ , maximálne rozdiely anomálie výšky  $|\delta\zeta| = 1,50 \text{ m}$ , stredná chyba tiažového potenciálu  $\sigma_{W_{EGM\ 96}}$  a stredná chyba anomálie výšky  $\sigma_{\zeta_{EGM\ 96}}$ :

$$\sigma_{W_{EGM\ 96}} = \sqrt{\frac{\sum_{i=1}^n \delta W_i^2}{n-1}} = \pm 6.8 \text{ m}^2\text{s}^{-2}, \quad \sigma_{\zeta_{EGM\ 96}} = \sqrt{\frac{\sum_{i=1}^n \delta\zeta_i^2}{n-1}} = 0.46 \text{ m}, \quad i \in \langle 1, n \rangle,$$

kde  $n$  je počet bodov.

## 5. Conclusion

The inaccuracies in the EGM 96 model estimation at territory of Slovakia are expressed by the maximal differences of the gravity potential  $|\delta W| = 20 \text{ m}^2\text{s}^{-2}$ , the maximal difference of height anomalies  $|\delta\zeta| = 1.50 \text{ m}$ , the mean error of gravity potential  $\sigma_{W_{EGM\ 96}}$  and the mean error of height anomaly  $\sigma_{\zeta_{EGM\ 96}}$ :

where  $n$  is the number of points.

## 6. Literatúra - References:

- [1] BURKE, K. F., BURŠA, M., RADĚJ, K., ŠÍMA, Z., TRUE, S. A., VATRT, V.: *Working Group Global Geodesy Topics: Satellite Altimetry Applications*, Prague 1996.
- [2] BURKE, K. F., BURŠA, M., RADĚJ, K., ŠÍMA, Z., TRUE, S. A., VATRT, V.: *Geopotential Model Testing Network: its Present and Applying, Working Group Global Geodesy Topics: Satellite Altimetry Applications*, Proceedings at the TS ACR, presented at the 3rd Common Seminar, Bratislava 1996.
- [3] BURKE, K. F., TRUE, S. A., BURŠA, M., RADĚJ, K.: *Accuracy Estimates of Geopotential Models and Global Geoids*, Proceedings of Symposium No.116 held in Boulder, CO, USA, July 12, 1995, Edited by R.H. Rapp, A. A. Cazenave and R. S. Narem, Springer Verlag 1996.
- [4] BURŠA, M., RADĚJ, K., ŠÍMA, Z., TRUE, S. A., VATRT, V.: *Tests for Accuracy of Recent Geopotential Models, International Geoid Service Bull. No. 6, D.I.I.A.R.- Politecnico di Milano, Italy 1997.*
- [5] BURŠA, M., KOSTELECKY, J.: *Space geodesy and space geodynamics*, Published by the Ministry of Defense - Topographic Department of the General Staff of the Army of the Czech Republic, Prague 1999.
- [6] BURŠA, M., BYSTRZYCKÁ, B., RADĚJ, K., VATRT, V.: *Estimation of the accuracy of geopotential models*, Studia geoph. et geod. 39, Prague 1995.
- [7] EREMEEV, V. F., YURKINA, M. I.: *Theory of Heights in the Earth's Gravity Field*, Nedra, Moscow 1972.
- [8] HEISKANEN, W., MORITZ, H.: *Physical Geodesy*, Freeman Wh and Co, San Francisco and London 1967.
- [9] HOBSON, E.W.: *The theory of spherical and ellipsoidal harmonics*, Cambridge University Press, Cambridge 1931.
- [10] LEMOINE, F. G. et al.: *The Development of the NASA GSFC and NIMA Joint Geopotential Model*, Proceedings of the International Symposium on Gravity, Geoid and Marine Geodesy, The University of Tokyo, Japan 1996.
- [11] MELCHIOR, P.: *The Tides of the Planet Earth*, Pergman Press, Oxford 1983.
- [12] MOLODENSKY, M. S.: *Fundamental Problems of Geodetic Gravimetry*, TRUDY TsNIIGAIK 42, Geodezizdat, Moscow 1945.
- [13] VATRT, V.: *Methodology for testing Geopotential Models Specified in Different Tide Systems*, Studia geoph. et geod. 43, Prague 1999.

Mária Franeková \*

# MATEMATICKÝ APARÁT PRE VÝPOČET PRAVDEPODOBNOSTI CHYBY DEKODÉROV BLOKOVÝCH KÓDOV

## MATHEMATICAL APPARATUS FOR ERROR PROBABILITY DETERMINATION OF BLOCK CODE DECODERS

Článok sa zaoberá problematikou bezpečnej komunikácie v uzavretých prenosových systémoch pri použití blokových systematických  $(n, k)$  kódov. Je uvedený matematický aparát pre výpočet pravdepodobnosti nedetegovanej chyby pre kódy so známou a neznámou váhovou štruktúrou. Číselné výsledky sú platné pre symetrický binárny kanál, za predpokladu nezávislých chýb v kanáli.

This paper deals with safety - related communication in closed transmission systems when block systematic  $(n, k)$  safety codes are used. The mathematical apparatus for calculation of probability of undetected sequence error is described for codes, with known and unknown weight structure. The numerical results are valid for a Symmetric Binary Channel when the occurrence of independent errors is assumed.

### 1. Úvod

Úroveň bezpečnosti pri prenose informácie cez komunikačný kanál je daná sumárnou hodnotou zloženou z integrity, dostupnosti a dôvernosti. Typické poradie kodérov a dekodérov v komunikačnom reťazci je ukázané na obr. 1.

### 1. Introduction

The level of security for transmission of information across the communication channel is calculated as a summary value of integrity, availability and confidentiality. A typical order of coders and decoders in the communication chain is shown in the Fig. 1.

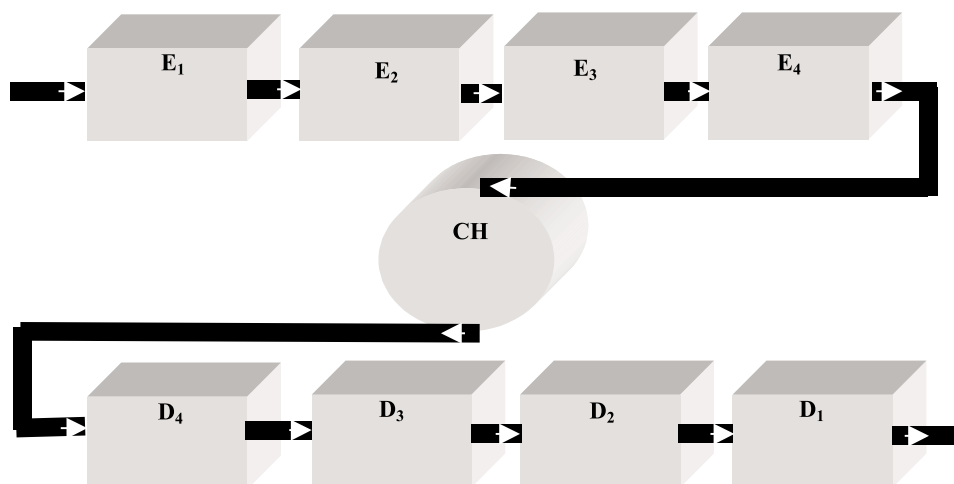

Obr. 1. Komunikačný reťazec pre prenos informácie  
Fig. 1. Communication chain for transmission of information

Poradie komponentov pre prenos informácie v komunikačnom reťazci nie je náhodné, každý blok má presne určenú lokalitu.

The orders of components in a communication chain for transmission of information are not random; every block has its fixed locality.

\* Ing. Mária Franeková, PhD.

Department of Information and Safety Systems, Faculty of Electrical Engineering, University of Žilina, Veľký diel, SK-010 26 Žilina, Slovak Republic, Tel.: +421-89-5133 248, E-mail: frane@fel.utc.sk

Poradie dvojíc komponentov kodér/dekodér v komunikačnom reťazci je nasledovné:

$E_1/D_1$	- kompresný (zdrojový) kodér/dekodér
$E_2/D_2$	- šifrovací kodér/dekodér
$E_3/D_3$	- zabezpečovací (kanálový) kodér/dekodér
$E_4/D_4$	- modulátor/demodulátor
$CH$	- prenosový kanál

V niektorých prípadoch nie je nutné použiť všetky uvedené komponenty, to závisí od konkrétnej aplikácie. Tiež kanál môže byť napríklad pamäť, do ktorej je informácia zapísaná alebo zakódovaná a potom je čítaná alebo dekodovaná.

Nezmenenie a nenarušenie informácie počas prenosu možno zabezpečiť pomocou zabezpečovacích kódov, ktoré by mali byť schopné ochrániť systém podľa požadovanej úrovne integrity.

V uzavretých prenosových systémoch podľa normy prEN 159-1 [1] môže byť použitý ako zabezpečovací kód iba detekčný kód. Pre splnenie požadovanej úrovne bezpečnosti je potrebné detegovať typické zhluky. Tieto môžu byť: náhodné chyby, zhluky chýb, systematické alebo kombinované chyby. Úroveň bezpečnosti je efektívna vtedy, ak pravdepodobnosť nedetegovanej chyby kódového slova je vyššia než požadovaná hodnota. Tieto požiadavky možno realizovať pomocou veľkého množstva zabezpečovacích kódov [2], [5]. Frekvenciou závislosťou, ktorá ohodnocuje úroveň bezpečnosti je pravdepodobnosť chyby kódového slova  $p_e$  v závislosti od bitovej chybovosti  $p_b$  používaného kanála. Každý odporučený alebo použitý kód v uzatvorenom prenosovom systéme je potrebné analyzovať a vypočítať maximum pravdepodobnosti nedetegovanej chyby kódového slova pre použitý prenosový kanál. Pri výpočte možno použiť štatistické hodnoty pravdepodobnosti chyby elementárneho symbolu (bitu) niektorých typických kanálov. Binárny symetrický kanál alebo kanál s gausovským aditívnym šumom sú veľmi často používané matematické modely kanálov, pri vyjadrení matematického aparátu v sledovanej oblasti [3].

V článku sú uvedené metódy výpočtu pravdepodobnosti nedetegovanej chyby kódového slova systematických blokových kódov:

1. v prípade, keď je známa váhová funkcia kódových zložiek (napr. Hammingove kódy)
2. v prípade, keď nie je jednoduché generovať váhovú funkciu kódových slov (napr. binárne BCH kódy).

## 2. Metódy výpočtu pravdepodobnosti nedetegovanej chyby kódového slova

Pri niektorých postupoch výpočtu pravdepodobnosti chyby [2], [4] je potrebné poznať všetky kódové slová kódu. Potom pravdepodobnosť nedetegovanej chyby kódového slova  $p_{e1}$  pre binárny symetrický kanál (BSC) možno vypočítať podľa (1):

$$P_{e1} = \sum_{i=\left\lfloor \frac{d_{min}+1}{2} \right\rfloor}^n A_i p_b^i (1-p_b)^{n-i} \quad (1)$$

The order of couples of components in the communication chain is the following:

$E_1/D_1$	- compression (source) encoder/decoder
$E_2/D_2$	- ciphering encoder/decoder
$E_3/D_3$	- safety (channel) encoder/decoder
$E_4/D_4$	- modulator/demodulator
$CH$	- transmission channel

In some cases it is not necessary to use all the above shown components, depending on their concrete application. Also the channel can be e.g. a memory, where information is written or coded and then is read or decoded.

The non-modification and non-corruption of information during transmission can be secured by safety codes, which should be capable of protecting the system, in the required level of integrity.

In the closed transmission system according to the norm prEN 159-1 [1] only the error detection code can be used as a safety code. For fulfilling the required safety integrity level it is necessary to detect typical errors. These errors can be random errors, burst errors, systematic or combined errors. The level of security is effective when the probability of undetected sequence error is bigger than a demanded value. These requirements can be realized with the sufficiently complex safety codes [2], [5]. A frequent function relation used for evaluation of a safety level is error probability of code word  $p_e$  depending on a bit error rate  $p_b$  of the used channel. It is necessary to analyze and determine the utmost probability of an undetected sequence error for the used transmission channel for every recommended or used code in a closed transmission system. In the process of calculation the statistical values of probability of bit error for some typical channels can be used. Binary Symmetric Channel or Additive White Gaussian Noise Channel is an often-used mathematical model of a channel for the expression of mathematical apparatus in this area [3].

In the article the following methods of the calculation of probability of undetected sequence error of systematic block codes are introduced:

1. in a case when a weight function of code words is known (e.g. Hamming codes)
2. in a case when it is not easy to generate the weight function of code words (e.g. BCH codes).

## 2. Methods for calculation of probability of an undetected sequence error

An approach of determination of error probability [2], [4] needs to know all sequences (or code words) of code. Then the probability of an undetected sequence error  $p_{e1}$  for Binary Symmetric Channel (BSC) can be calculated according to (1):

$$P_{e1} = \sum_{i=\left\lfloor \frac{d_{min}+1}{2} \right\rfloor}^n A_i p_b^i (1-p_b)^{n-i} \quad (1)$$

Kde:  $d_{min}$  je minimálna Hammingova vzdialenosť kódu

$A_i$  je celkový počet kódových slov s váhou  $i$

$p_b$  je bitová chybovosť kanála

Predpokladáme, že chyby v kanáli sú nezávislé a vyskytujú sa s bitovou chybovosťou  $p_b$  a ich výskyt možno aproximovať hustotou rozdelenia pravdepodobnosti podľa binomického rozloženia.

Hammingove perfektné  $(n, k)$  kódy [5] sú jedny z mála skupín kódov, kde je známa kompletná váhová funkcia  $A(x)$ :

$$A(x) = \sum_{i=0}^n A_i x^i \quad (2)$$

Váhová funkcia pre Hammingove kódy s  $d_{min} = 3$  a dĺžkou kódového slova  $n = 2^r - 1$  ( $r$  je počet redundantných bitov) je [2]:

$$A(x) = \frac{1}{n+1} [(1+x)^n + n(1+x)^{(n-1)/2} \cdot (1-x)^{(n-1)/2}] \quad (3)$$

Pre kódové slová s väčšou dĺžkou  $n$  môže byť výpočet  $p_{e1}$  komplikovaný. Veľkou výhodou je, že hodnoty funkcie  $A(x)$  sú symetrické pozdĺž  $(n-1)/2$ , čo zjednodušuje výpočet. Hammingove kódy s  $d_{min} = 3$  sa dajú ľahko prekonvertovať na Hammingove kódy s  $d_{min} = 4$  pridaním jedného paritného bitu. To spôsobí, že všetky kódové slová s váhou  $i$  (pre nepárnu váhu) sa stanú kódovými slovami s váhou  $i+1$ .

**Pozn.:** Platí len pre rozšírené Hammingove kódy s párnou paritou. Výsledky pravdepodobnosti nedetegovanej chyby kódového slova pre rozšírený Hammingov kód sú uvedené v článku [5].

Nie pre všetky zabezpečené blokové kódy je jednoduché generovať váhovu funkciu kódových slov  $A(x)$ . Potom pravdepodobnosť nedetegovanej chyby kódového slova nemôže byť počítaná podľa vzťahu (1). V uzatvorených prenosových systémoch sú veľmi často používanými detekčnými kódmi binárne cyklické kódy, s dĺžkou kódového slova  $n$  a generačným polynómom  $g(x)$  [5]. Rovnicu (1) možno modifikovať podľa [4], ak hodnota  $A_i$  je aproximovaná pomocou (4):

$$A_i \cong \frac{1}{2^{n-k}} \binom{n}{i} \quad (4)$$

Potom pravdepodobnosť nedetegovanej chyby kódového slova je daná vzťahom (5):

$$p_{e2} \cong \frac{1}{2^{n-k}} \sum_{i=d_{min}}^n \binom{n}{i} p_b^i (1-p_b)^{n-i} \quad (5)$$

Ak súčin  $np_b \ll 1$  môže byť suma v (5) aproximovaná prvým členom sumy (6):

$$p_{e3} \cong \frac{1}{2^{n-k}} \binom{n}{d_{min}} p_b^{d_{min}} (1-p_b)^{n-d_{min}} \quad (6)$$

Je evidentné, že vo vzťahu (6) je potrebné poznať okrem parametrov  $(n, k)$  aj minimálnu Hammingovu vzdialenosť kódu  $d_{min}$  kódových slov. Ak je jej hodnota neznáma, na výpočet  $d_{min}$  možno

Where:  $d_{min}$  is minimal Hamming distance of code

$A_i$  is the total number of sequences in the code with weight  $i$

$p_b$  is a bit error rate of channel

Provided that errors in the channel are independent and occur with a bit error rate  $p_b$  and the occurrence of error might be approximated by a binomial density of probability.

Hamming perfect  $(n, k)$  codes [5] belong to a few classes of codes for which the complete weight function of code words  $A(x)$  is known, where  $A(x)$  is the weight-enumerating function of a code:

$$A(x) = \sum_{i=0}^n A_i x^i \quad (2)$$

The weight-enumerating function for the distance-3 Hamming codes of code words length  $n = 2^r - 1$  (where,  $r$  is number of redundancy bits) is [2]:

$$A(x) = \frac{1}{n+1} [(1+x)^n + n(1+x)^{(n-1)/2} \cdot (1-x)^{(n-1)/2}] \quad (3)$$

For sequences of a larger length  $n$  calculations of  $p_{e1}$  can be complicated a big advantage is that the values of function  $A(x)$  are symmetrical along the point  $(n-1)/2$ , what eases the calculation. The distance-3 Hamming codes can be converted in a very easy way to a minimum distance-4 code by appending one additional parity symbol to all code words. It causes that all weight- $i$  code words (with odd weight) become weight- $i+1$ .

**Note:** It is valid for expanded Hamming codes for even parity, only. The results of values of probability of undetected error for extended Hamming codes are shown in paper [5].

It is not easy to generate the weight function of code words  $A(x)$  for all safety block codes. Then the probability of undetected sequence error cannot be calculated by given (1). In the closed transmission system some types of binary symmetric cyclic  $(n, k)$  codes with code word of lengths  $n$  and with generate polynomial  $g(x)$  as the detection codes are very often used. Equation (1) can be modified [3], where value of  $A_i$  is approximated by (4).

$$A_i \cong \frac{1}{2^{n-k}} \binom{n}{i} \quad (4)$$

Then probability of an undetected sequence error is given by (5):

$$p_{e2} \cong \frac{1}{2^{n-k}} \sum_{i=d_{min}}^n \binom{n}{i} p_b^i (1-p_b)^{n-i} \quad (5)$$

If  $np_b \ll 1$  in (5) then, can be sum approximated by the first member of sum (6):

$$p_{e3} \cong \frac{1}{2^{n-k}} \binom{n}{d_{min}} p_b^{d_{min}} (1-p_b)^{n-d_{min}} \quad (6)$$

It is evident that in the relationship (6) it is necessary to know besides the parameters of  $n, k$ , also the minimum Hamming distance of code words  $d_{min}$ . If this value is unknown for determina-

použiť Gilbertovu nerovnosť pre párne kódové slová (7) a pre nepárne kódové slová (8).

$$2^k \sum_{i=0}^{(d_{min}-1)/2} \binom{n}{i} \leq 2^n \quad (7)$$

$$2^k \sum_{i=0}^{(d_{min}-2)/2} \binom{n-1}{i} \leq 2^{n-1} \quad (8)$$

Pre niektoré hodnoty  $(n, k)$  binárnych cyklických kódov a BCH kódov sú výsledky Gilbertovej nerovnosti tabelované [2], [4], [5].

### 3. Výsledky simulované počítačom

V príspevku sú uvedené príklady výpočtu hodnôt pravdepodobnosti nedetegovanej chyby kódového slova  $p_{e1}$ ,  $p_{e2}$  a  $p_{e3}$  vyjadrené vzťahmi (1), (5) a (6) pre interval bitovej chybovosti kanála od  $p_b = 10^{-9}$  do  $p_b = 0,5$ . Prvá metóda výpočtu, zo znalosti váhovej funkcie kódu, je demonštrovaná na príklade rozšíreného Hammingovho kódu (128,120) s  $d_{min} = 4$ , ktorý možno použiť v uzatvorenom prenosovom systéme pre detekciu dvoch chýb v kódových slovách. Číselné hodnoty sú uvedené v tab. 1 a grafické závislosti na obr. 2. Pre porovnanie hodnôt počítaných podľa (5) a (1) sú vypočítané aj hodnoty  $p_{e2}$  a v tab. 1 je uvedená odchýlka medzi nimi  $\delta = abs(p_{e1} - p_{e2})$ . Váhová funkcia Hammingovho (128,120) kódu je určená pomocou programu MATLAB. Výsledky pravdepodobnosti nedetegovanej chyby kódového slova podľa (1) sú vypočítané pomocou programu DERIVE.

Pravdepodobnosť nedetegovanej chyby kódového slova Hammingovho (128,120) kódu Tab. 1

$p_b$	$2^{-1}$	$10^{-2}$	$10^{-3}$	$10^{-4}$	$10^{-5}$	$10^{-6}$	$10^{-7}$	$10^{-8}$	$10^{-9}$
$p_{e1}$	3,9 e-3	2,58 e-4	7,54 e-8	8,42 e-12	8,52 e-16	8,53 e-20	8,53 e-24	8,53 e-28	8,53 e-32
$p_{e2}$	3,9 e-3	1,57 e-4	3,77 e-8	4,12 e-12	4,16 e-16	4,16 e-20	4,16 e-24	4,16 e-28	4,16 e-32
$\delta$	0	1,01 e-4	3,77 e-8	4,30 e-12	4,36 e-16	4,37 e-20	4,37 e-24	4,37 e-28	4,37 e-32

Výsledky v tab. 1 a na obr. 2 ukazujú, že hodnoty pravdepodobnosti chyby počítané podľa vzťahov (1) a (5) sa odlišujú minimálne. Odchýlka  $\delta$  medzi hodnotami je konštantná v mantise (hodnota 4,37) od hodnoty bitovej chybovosti  $p_b = 10^{-6}$ . Od hodnoty  $p_b = 10^{-2}$  sa odchýlka  $\delta$  líši pravidelne o štyri rády v exponente.

Druhá metóda výpočtu pravdepodobnosti chyby pre blokové kódy s neznámou váhovou funkciou je ukázaná na príklade binárneho BCH kódu (255,199) s  $d_{min} = 15$ . Kód dokáže detegovať 14 chýb v kódovej zložke. Výsledky sú uvedené v tab. 2 pre rovnaký interval bitovej chybovosti. Hodnoty  $p_{e2}$  a  $p_{e3}$  sú určené podľa

tion of  $d_{min}$  Gilbert's unequation for even length of code words (7) and for odd length of code words (8) can be used.

$$2^k \sum_{i=0}^{(d_{min}-1)/2} \binom{n}{i} \leq 2^n \quad (7)$$

$$2^k \sum_{i=0}^{(d_{min}-2)/2} \binom{n-1}{i} \leq 2^{n-1} \quad (8)$$

For some valid combination  $(n, k)$  of binary cyclic codes and BCH codes the values of Gilbert's unequation are tabulated [2], [4], [5].

### 3. Computer simulation results

In the paper are shown examples of calculation of the values of probability of an undetected sequence error  $p_{e1}$ ,  $p_{e2}$  and  $p_{e3}$  given by relations (1), (5) and (6) for interval of a bit error rate of a channel from  $p_b = 10^{-9}$  to  $p_b = 0,5$ . The first method of calculation, based on knowledge of the weight function of code, is demonstrated by an example of extended Hamming (128,120) code with  $d_{min} = 4$ , which can be used in the closed transmission system for detection of two errors in every code word. The numerical results are shown in Tab. 1 and the graphical results in Fig. 2. For comparison of the values given by (5) and (1) are calculated the results of  $p_{e2}$ , too and in Tab. 1 the deviation between them  $\delta = abs(p_{e1} - p_{e2})$  is determined. The weight function of Hamming (128,120) code according to (3) and undetected sequence error probability according to (1) are calculated via program MATLAB. The values of undetected sequence error probability given by (5), (when the weight function of code words is unknown), are calculated with the help of program DERIVE.

The undetected sequence error probability for Hamming (128, 120) code Tab. 1

$p_b$	$2^{-1}$	$10^{-2}$	$10^{-3}$	$10^{-4}$	$10^{-5}$	$10^{-6}$	$10^{-7}$	$10^{-8}$	$10^{-9}$
$p_{e1}$	3.9 e-3	2.58 e-4	7.54 e-8	8.42 e-12	8.52 e-16	8.53 e-20	8.53 e-24	8.53 e-28	8.53 e-32
$p_{e2}$	3.9 e-3	1.57 e-4	3.77 e-8	4.12 e-12	4.16 e-16	4.16 e-20	4.16 e-24	4.16 e-28	4.16 e-32
$\delta$	0	1.01 e-4	3.77 e-8	4.30 e-12	4.36 e-16	4.37 e-20	4.37 e-24	4.37 e-28	4.37 e-32

The results in Tab. 1 and Fig. 2 show that the values of an undetected sequence error probability, calculated by relations (5) and (1) are minimally distinguished. The deviation between the values is constant in mantisa (value 4.37) for bit error rate from  $p_b = 10^{-6}$ . The deviation from value  $p_b = 10^{-2}$  is periodically different by four orders in the exponent.

The second method of calculation of error probability for block codes with an unknown weight function is shown for binary BCH (255,199) code with  $d_{min} = 15$ . The code can detect 14 independent errors in every code word. The results are shown in Tab. 2 for the same interval of a bit error rate.

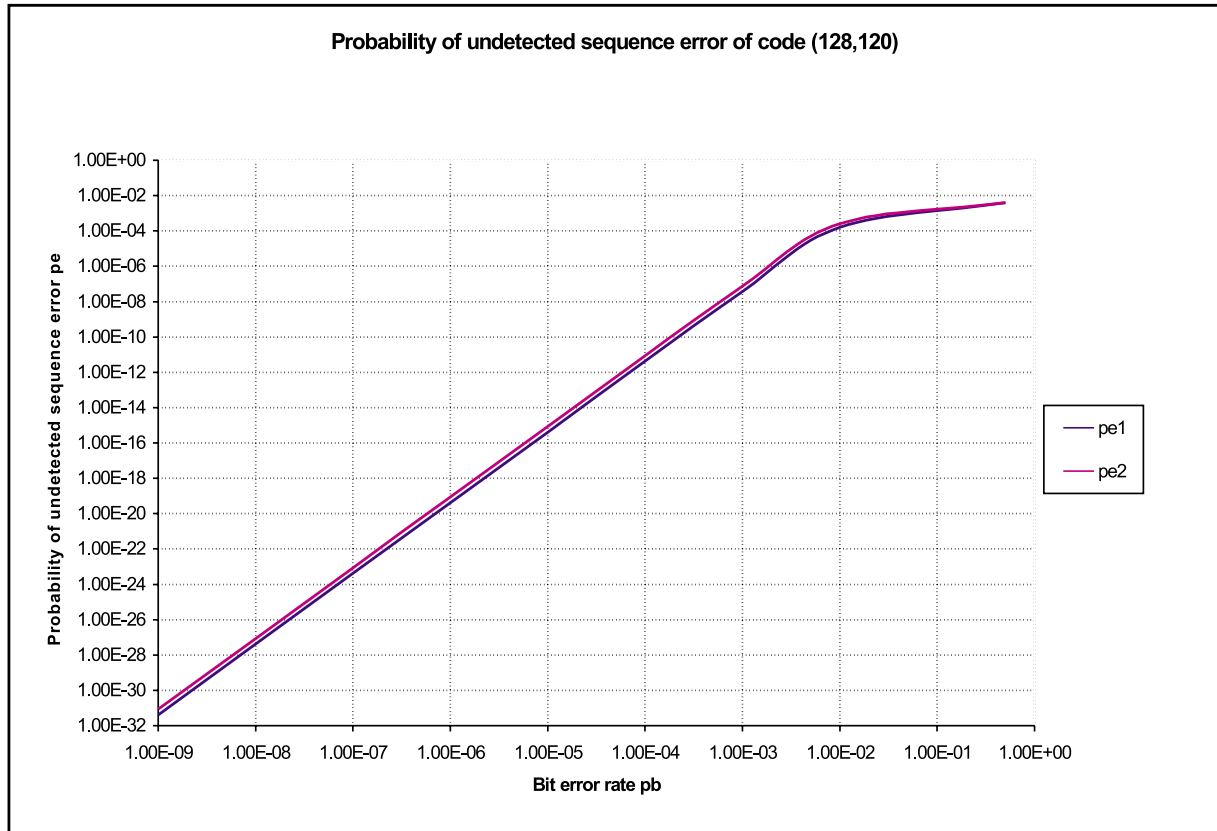

Obr. 2. Grafické výsledky pravdepodobnosti chyby nedetegovaného slova pre Hammingov (128,120) kód  
Fig. 2. Graphical results of the probability of undetected sequence error for Hamming (128,120) code

vzťahov (5) a (6). Hraničná hodnota bitovej chybovosti  $p_b$ , od ktorej možno vzťah (5) aproximovať vzťahom (6) pre dĺžku kódového slova  $n = 255$ , je  $p_b = 10^{-3}$ .

Pravdepodobnosť nedetegovanej chyby pre binárny BCH (255, 199,14) kód Tab. 2

$p_b$	$2^{-1}$	$10^{-2}$	$10^{-3}$	$10^{-4}$	$10^{-5}$	$10^{-6}$	$10^{-7}$	$10^{-8}$	$10^{-9}$
$p_{e2}$	1,3 e-17	9,2 e-25	6,9 e-39	8,5 e-54	8,7 e-69	8,7 e-84	8,7 e-99	8,7 e-114	8,7 e-129
$p_{e3}$	1,5 e-17	7,8 e-25	6,8 e-39	8,5 e-54	8,7 e-69	8,7 e-84	8,7 e-99	8,7 e-114	8,7 e-129

#### 4. Záver

Počas prenosu informácie medzi zabezpečovacími systémami musí byť garantovaná požadovaná hranica pravdepodobnosti chyby. Preto nutnou súčasťou celkovej analýzy bezpečnosti je aj analýza bezpečnosti použitého blokového kódu. V príspevku sú uvedené dve metódy výpočtu pravdepodobnosti nedetegovanej chyby kódového slova, keď poznáme všetky kódové zložky kódu a v prípade, keď je veľmi ťažké generovať váhovú funkciu kódu. Porovnanie

The undetected sequence error probability for binary BCH (255, 199,14) code Tab. 2

$p_b$	$2^{-1}$	$10^{-2}$	$10^{-3}$	$10^{-4}$	$10^{-5}$	$10^{-6}$	$10^{-7}$	$10^{-8}$	$10^{-9}$
$p_{e2}$	1.3 e-17	9.2 e-25	6.9 e-39	8.5 e-54	8.7 e-69	8.7 e-84	8.7 e-99	8.7 e-114	8.7 e-129
$p_{e3}$	1.5 e-17	7.8 e-25	6.8 e-39	8.5 e-54	8.7 e-69	8.7 e-84	8.7 e-99	8.7 e-114	8.7 e-129

The values of  $p_{e2}$  and  $p_{e3}$  are calculated according to (5) and (6). The bounded value for a bit error rate  $p_b$  from which relation (5) can be approximated by relation (6) for code word length  $n = 255$  is  $p_b = 10^{-3}$ .

#### 4. Conclusion

During communication between safety-related systems the required bound of undetected sequence error probability must be guaranteed. Therefore with some type of safety codes used of data transmission the analysis is a necessary part of the total analysis of security. In the paper two methods of calculation of the probability of an undetected sequence error are dealt with - when all code sequences of code are known and when the weight function

výsledkov pravdepodobnosti nedetegovanej chyby kódového slova počítaných podľa vzťahov (1), (5) a (6) je realizované na príkladoch systematických blokových kódov - Hammingov (128,120) a binárny BCH kód (255, 199, 14). Výsledky pre  $p_{e1}$  a  $p_{e2}$  a pre  $p_{e2}$  a  $p_{e3}$  uvedené v tab. 1 a tab. 2 sú rádovo ekvivalentné, čo je veľmi dôležitý poznatok. Výsledky sú platné len pre nezávislé chyby v kanáli. Z obr. 1 vyplýva, že výsledky pravdepodobnosti  $p_{e1}$  a  $p_{e2}$  limitujú pre  $p_b = 0,5$  k hodnote  $2^{-(n-k)}$ , čo podľa [1] je najnižšia možná hodnota pravdepodobnosti nedetegovanej chyby pri použití blokových  $(n, k)$  kódov.

of code words is very difficult to generate or it is unknown. The comparison of results of probability of undetected sequence error calculated by relations' (1), (5) and (6) are performed on the examples of systematic block codes - Hamming code (128,120) and binary BCH code (255, 199). The results of probability  $p_{e1}$ ,  $p_{e2}$  and  $p_{e2}$ ,  $p_{e3}$  shown in Tab. 1 and Tab. 2 are equivalent with the order, which is very a important evidence. The results are valid only for independent errors in the channel. From Fig. 1 follows that curves of  $p_{e1}$  and  $p_{e2}$  for  $p_b = 0,5$  are limited to the value  $2^{-(N-k)}$ , which is according to [1] the lowest value of error probability valid for block  $(n,k)$  codes.

## 5. Literatúra - References

- [1] PrEN 159-1: *Railway applications - Communication, signalling and processing systems*, Part 1: Safety-related communication in closed communication system
- [2] ADÁMEK, J.: *Foundation of coding*, Theory and applications of Error-Correcting Codes with an Introduction to Cryptography and information Theory,
- [3] CLARK, G., CAIN, B.: *Error-Correction Coding for Digital Communications*, Plenum Press, New York, 1988
- [4] HRDINA, Z., VEJRAŽKA, F.: *Digitální rádiová komunikace*, skriptum ČVUT, Praha, 1994
- [5] FRANEKOVÁ, M., BUBENÍKOVÁ, E.: *The calculation of the probability of undetected sequence error for the ARQ systems*, MOSIS 2000, máj 2000, Rožnov pod Radhoštěm, pp. 203-208

Marian Josko - Marcin Jarmuzek \*

# HODNOTENIE ADHEZÍVNYCH SPOJENÍ MEDZI POVLAKOM A SUBSTRÁTOM S POUŽITÍM ULTRAZVUKOVEJ SPEKTROSKOPIE

## EVALUATION OF ADHESIVE JOINTS BETWEEN COATING AND SUBSTRATE USING ULTRASONIC SPECTROSCOPY

*V článku je vykonaná teoretická analýza ultrazvukového impulzného signálu a experimentálne vyšetovanie na skúšobných vzorkách. Skúšobné vzorky boli vyrobené z konštrukčných ocelí a pokryté povlakmi z tmelov a lakov. Študovali sme predovšetkým citlivosť vybraných parametrov ultrazvukového spektra na zmeny stavu substrátu a prílnavosti. Bolo konštatované, že nepravidelnosti substrátu a hrúbka povlakov ovplyvňujú spektrum ultrazvukového signálu.*

*In the paper the theoretical analysis of ultrasonic impulse signal and experimental investigations on some specimens was carried out. The specimens were made of constructional steel on which some coatings of automotive putty and lacquer were layered. In particular, the sensitivity of selected parameters of ultrasonic spectrum on changes of condition of the substrate and bonded materials was studied. It was noticed that irregularities of substrate and the thickness of coatings layered, influence parameters of the ultrasonic signal spectrum.*

### 1. Introduction

A lack or a loss of adherence between coatings and substrate are caused by loosening of coating from a substrate. All areas of the loosening can be considered as flat defects. They would be detected by a traditional amplitude-time ultrasonic method, and they can influence also an amplitude-frequency spectrum of ultrasonic signal descended from a space of the joint of coating with the substrate. Some positive examples of application of ultrasonic spectroscopy for evaluation of adhesive bonds are known already [1-3].

The ultrasonic spectroscopy is a very essential supplement to ultrasonic defectoscopy, because through an analysis of ultrasonic signal in frequency domain, we can obtain some additional data concerning detected faults. In some cases, it is possible to receive the fundamental information about shape and orientation of defects as well as about the structure of materials [4], especially using ultrasonic broadband transducers.

The purpose of this paper is an assessment of suitability of spectral analysis of ultrasonic signal, whose sources are medium-damping transducers, for evaluation of adhesive joints of two sorts coating layered on steel substrate. The role of coatings plays an automotive lacquer layers and an automotive putty. The range of our considerations is limited to an assessment of sensitivity of

selected parameters of ultrasonic spectrum on changes of substrate condition and bonded materials.

### 2. Theoretical analysis

On the base of [5], we can express the amplitude of harmonic components of ultrasonic signal  $h_n$  by a typical wave dependence:

$$h_n = Af_0\tau \left| \frac{\sin\left(\left(\frac{c}{\lambda} - nf_0\right)2\pi\tau\right)}{\left(\frac{c}{\lambda} - nf_0\right)2\pi\tau} - \frac{\sin\left(\left(\frac{c}{\lambda} + nf_0\right)2\pi\tau\right)}{\left(\frac{c}{\lambda} + nf_0\right)2\pi\tau} \right| \quad (1)$$

where:  $A$  – amplitude of ultrasonic signal,  
 $f_0$  – frequency of impulse generation,  
 $\tau$  – duration of impulse,  
 $c$  – velocity of ultrasonic wave in the medium,  
 $\lambda$  – wavelength of ultrasonic wave,  
 $n$  – natural number.

The wavelength of ultrasonic wave  $\lambda$  can be connected with the dimension of the planar defect  $d$  using the below equation:

$$\lambda = zd \quad (2)$$

\* Dr. Ing. Marian Josko, Mgr. Ing. Marcin Jarmuzek

<sup>1</sup>Poznan University of Technology, Institute of Working Machines and Motor Vehicles, Piotrowo 3, 60-965 Poznan, Poland, Tel.: +48-061-6652247, Fax: +48-061-6652736, E-mail: Marian.Josko@put.poznan.pl

<sup>2</sup>Postgraduate Study Candidate, MPK, Ltd. – Municipal Transport Company, ul. Głogowska 131/133, 60-244 Poznan, Poland, Tel: +48-061-8699361, Fax: +48-061-8791681.

where:  $d$  – average size of planar defect on the adhesive boundary,  
 $z$  – factor of proportionality (grade of commensurability).

Including (2) in the expression (1), the mathematical relationship between the amplitude of harmonic components of ultrasonic signal  $h_n$  and average size of planar defect  $d$  (for example the dimension of the loosening of coating from substrate), can be presented in the following formula:

$$h_n = Af_0\tau \left| \frac{\sin\left(\left(\frac{c}{zd} - nf_0\right)2\pi\tau\right)}{\left(\frac{c}{zd} - nf_0\right)2\pi\tau} - \frac{\sin\left(\left(\frac{c}{zd} + nf_0\right)2\pi\tau\right)}{\left(\frac{c}{zd} + nf_0\right)2\pi\tau} \right| \quad (3)$$

where:  $A$  – amplitude of ultrasonic signal,  
 $f_0$  – frequency of impulse generation,  
 $\tau$  – duration of impulse,  
 $c$  – velocity of ultrasonic wave in the medium,  
 $z$  – factor of proportionality,  
 $d$  – average size of planar defect on the adhesive boundary,  
 $n$  – natural number.

It can be supposed that most of harmonic components of the ultrasonic signal are reduced, when the wavelength of ultrasonic wave  $\lambda$  is at least commensurable with the size of defect or considerably smaller than size of the planar defect  $d$  ( $\lambda \approx d$  or  $\lambda \ll d$ ). According to [6], both damping and dissipation of ultrasonic wave are the utmost in these cases.

The main parameters and the character of frequency spectrum envelope of sinusoidal ultrasonic impulses, illustrated by dependence (3), can be presented as in Fig 1. The planar defects on the boundary between coating and substrate could influence this spectrum as a band-pass filter, e.g. low-pass or high-pass. It means that defects can remove a certain part of components of the spectrum.

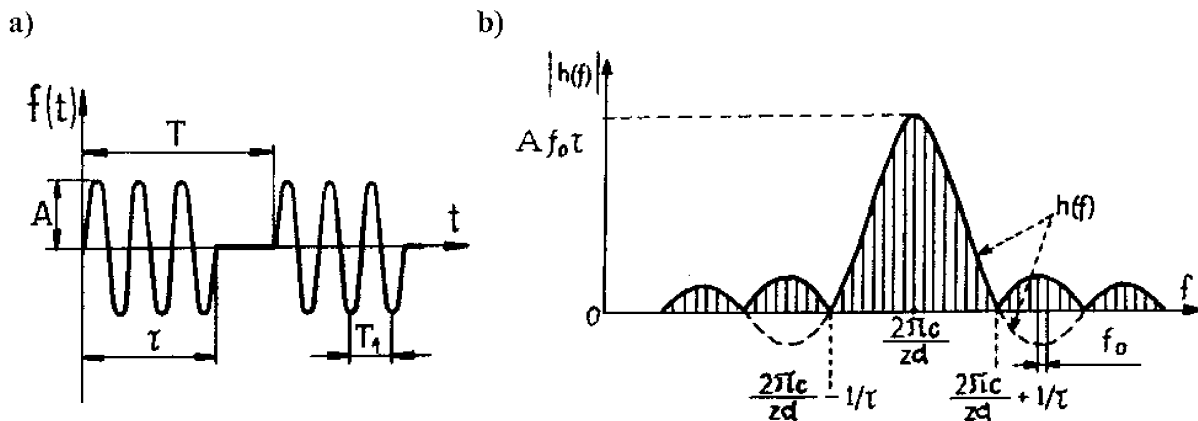

Fig. 1. The illustration of an ultrasonic signal analysis: a) parameters of ultrasonic impulses:  $f$  – frequency,  $A$  – amplitude,  $\tau$  – duration of impulse,  $T$  – period of impulses,  $T_1$  – ultrasonic wave period,  $t$  – time; b) the shape of envelope of the theoretical line impulse spectrum of ultrasonic signal – explanation of all symbols as in expression (3)

### 3. Experimental investigations

For investigation of sensitivity of paramount parameters of ultrasonic spectrum on changes of substrate irregularity and bonded materials, steel disc-shaped specimens were selected (Fig. 2). All specimens were made of construction steel, marked 40, according to Polish Standards (PN). Some main parameters of the steel are contained in Table 1. During the first stage of investigations, a number of ultrasonic commercial transducers made by INCO, Unipan and Karl Deutsch Company, at different frequencies, were applied. In the course of fundamental investigation 6L0°10C-INCO transducer was used only.

Some main parameters of substrate material  
– steel 40, according to PN-93/H-84019

Chemical constitution (wt.)							Mechanical properties			
C [%]	Mn [%]	Si [%]	Cr [%]	Mo [%]	Ni [%]	Cu [%]	Rm [MPa]	Re [MPa]	A5 [%]	Z [%]
0.41	0.67	0.33	0.09	0.11	0.08	0.12	572	335	19	45

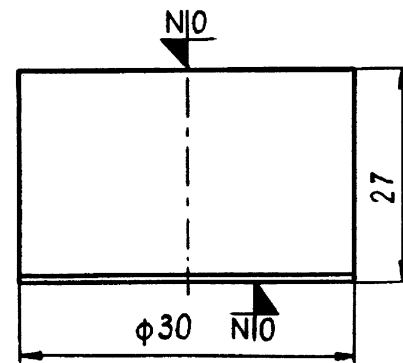

Fig. 2. Shape and dimension of the steel specimen (substrate with coating): N–O – ultrasonic transducer type transmitter-receiver

For generation and computer treatment of ultrasonic signals an ultrasonic, digital instrument (Ultramet UMT-12) was used. This instrument possessed function FFT and gave possibility automatically to determine  $f_r$  - peak (resonant) frequency and  $b$  - bandwidth of ultrasonic signals at  $-6$  dB. Other parameters of the ultrasonic signal spectrum were read out from the computer screen using so-called "frozen picture" and special computer cursor with given values of ultrasonic signal spectrum analyzed. These parameters are shown in Fig. 3.

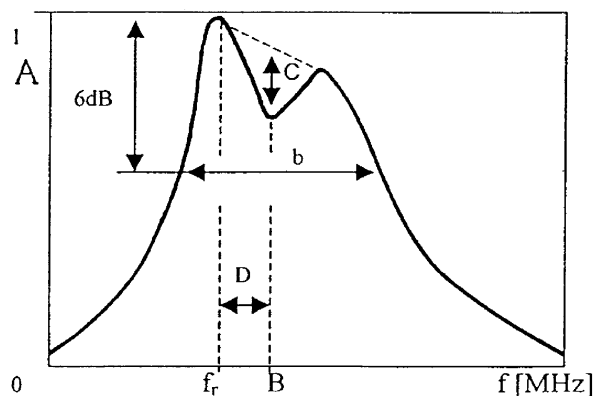

Fig. 3. Parameters of ultrasonic signal spectrum:  $f_r$ -peak (resonant) frequency,  $b$ -bandwidth ( $-6$  dB) of the signal spectrum,  $B$  - frequency of the deepest depression,  $C$  - depth of the deepest depression,  $D$  - parameter  $D = |f_r - B|$

The program of an experiment comprised some series of measurements of disc-shaped specimens for a diversified roughness of the substrate and a thickness of the coatings. Some main parameters of the roughness as  $R_a$ ,  $R_z$ ,  $S_m$  and  $R_t$  were determined with aid of surfer analyzer type Taylor Hobson Surtronic 3+. The diversification of substrate was achieved by grinding, sandblasting and shot-peening. On the substrate were layered coatings from automotive acrylic lacquer type PPG-Deltron and automotive polyester putty type Novol. An exact chemical composition and mechanical parameters of both materials used as coatings are reserved by producers. Table 2 reflects the program of preparing the specimens used during the experiment.

The specimens were monitored from the coating side and from the steel substrate side. Figure 4 shows examples of the frequency spectra, obtained in result of FFT transformation. All details of the investigations are enclosed in the thesis [7].

On the support of the data set of all considered parameters of the signal spectra, were plotted some dependencies between the parameters, selected of them are shown in Figs. 5 - 8.

#### 4. The principal conclusions

The theoretical analysis the problem studied and the experiments carried out allow us to recognize a feasibility of ultrasonic spectroscopy for the evaluation of adhesive joints and preliminary

The program of preparation of the specimens for investigations carried out

Tab. 2

Automotive acrylic lacquer - PPG-Deltron			Automotive polyester putty - Novol		
No spec.	Method of substrate preparation	Thickness of coating, [ $\mu$ m]	No spec.	Method of substrate preparation	Thickness of coating, [mm]
01/1	Mechanical grinding, ultrasonic decreasing in acetone	$64 \pm 5$	06/1	Mechanical grinding, ultrasonic decreasing in acetone	$0.65 \pm 0.05$
01/2	Mechanical grinding, ultrasonic decreasing in acetone	$62 \pm 5$	06/2	Mechanical grinding, ultrasonic decreasing in acetone	$0.65 \pm 0.05$
02/1	Sand-blasting EK100, ultrasonic decreasing in acetone	$60 \pm 5$	07/1	Mechanical grinding, ultrasonic decreasing in acetone	$1.25 \pm 0.05$
02/2	Sand-blasting EK100, ultrasonic decreasing in acetone	$56 \pm 5$	07/2	Mechanical grinding, ultrasonic decreasing in acetone	$1.20 \pm 0.05$
03/1	Sand-blasting EK60, ultrasonic decreasing in acetone	$60 \pm 5$	08/1	Mechanical grinding, ultrasonic decreasing in acetone	$1.65 \pm 0.05$
03/2	Sand-blasting EK60, ultrasonic decreasing in acetone	$58 \pm 5$	08/2	Mechanical grinding, ultrasonic decreasing in acetone	$1.60 \pm 0.05$
04/1	Sand-blasting EK40, ultrasonic decreasing in acetone	$60 \pm 5$	09/1	Mechanical grinding, ultrasonic decreasing in acetone	$2.40 \pm 0.05$
04/2	Sand-blasting EK40, ultrasonic decreasing in acetone	$62 \pm 5$	09/2	Mechanical grinding, ultrasonic decreasing in acetone	$2.45 \pm 0.05$
05/1	Shot-peening, ultrasonic decreasing in acetone	$60 \pm 5$	10/1	Mechanical grinding, ultrasonic decreasing in acetone	$3.85 \pm 0.05$
05/2	Shot-peening, ultrasonic decreasing in acetone	$56 \pm 5$	10/2	Mechanical grinding, ultrasonic decreasing in acetone	$3.90 \pm 0.05$

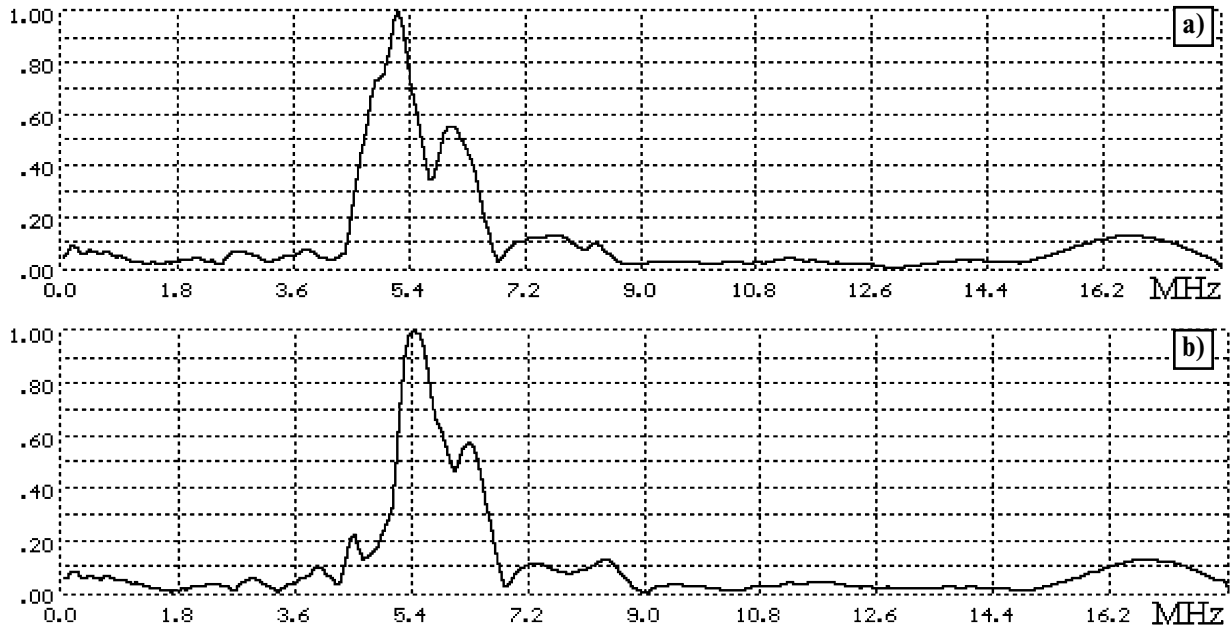

Fig. 4. Examples of frequency spectra for the following two cases: a) putty coating-thickness  $g = 1.2$  mm, measurement from substrate side, b) conditions of measurement as above -  $g = 1.6$  mm

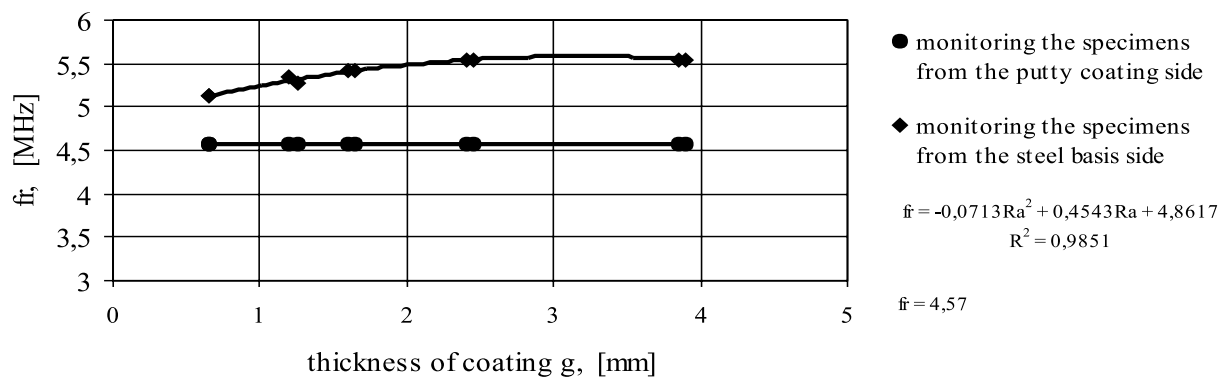

Fig. 5. The relationships between the peak (resonant) frequency -  $f_r$  of ultrasonic signal spectrum and the thickness of putty coatings ( $g$ )

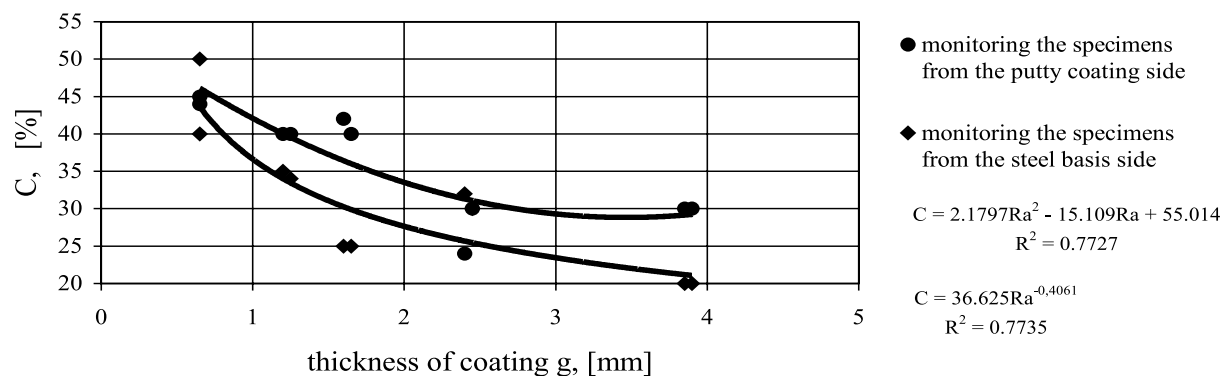

Fig. 6. The relationships between the depth of the deepest depression -  $C$  of ultrasonic signal spectrum and the thickness of putty coatings ( $g$ )

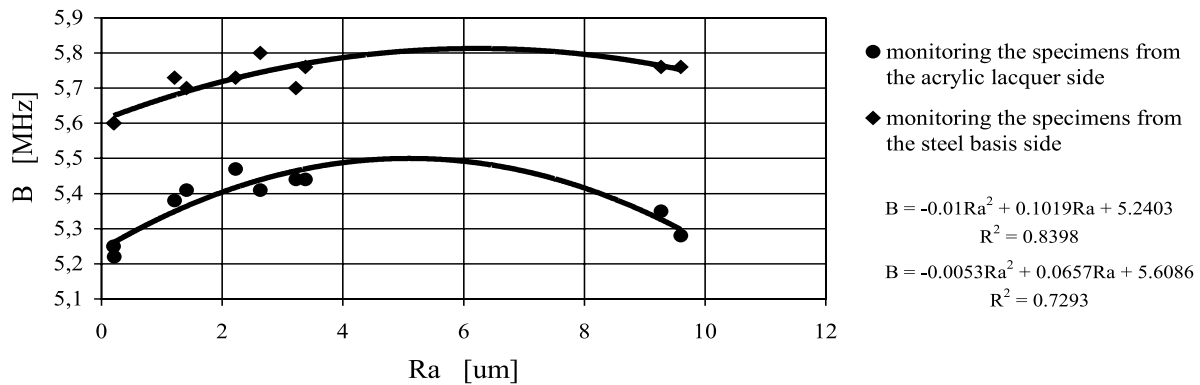

Fig. 7. The dependencies between the frequency of the deepest depression -  $f_r$  of ultrasonic signal spectrum and the roughness of substrate ( $Ra$ )

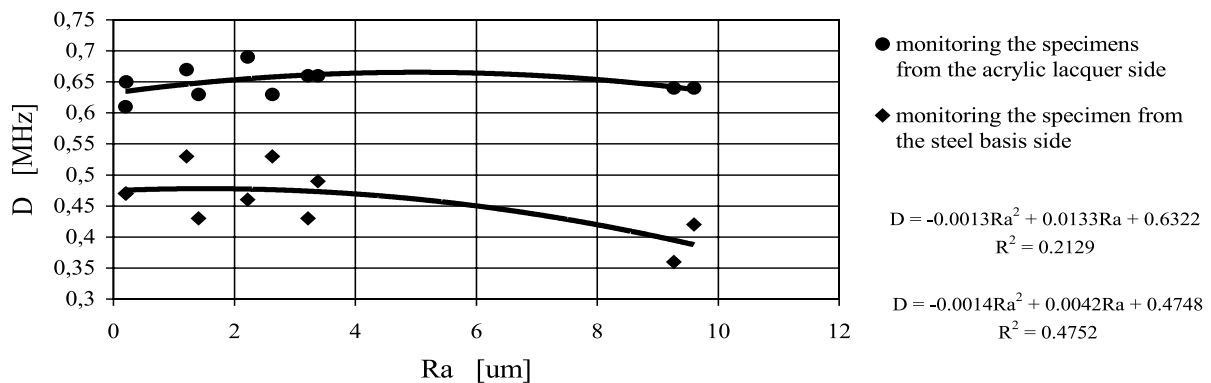

Fig. 8. The dependencies between the parameter -  $D = |f_{max} - B|$  of ultrasonic signal spectrum and the roughness of substrate ( $Ra$ )

to realize, in determined ranges, an assessment of selected adhesive joints between coating and substrate by the nondestructive method. Particularly, the main conclusions of our investigation can be reduced to the following statements:

- Between the main parameters of the real spectrum of ultrasonic signal and such a parameter of coating as  $g$  and of the substrate as  $Ra$ , there are regression relationships (Figs. 5 - 8);
- The most sensitive to change of coating thickness is the depth of the deepest depression of spectrum  $C$ , and to change of roughness substrate - frequency of the deepest depression  $B$ ;
- The ultrasonic spectrum analysis can be a useful method in the evaluation of adhesive joints type automotive lacquer and putty, connected with the steel substrate of grade 40, according to Polish Standards (PN);
- Both irregularities of the substrate and the thickness of coatings layered, influence the parameters of a ultrasonic signal spectrum, and ultrasonic spectroscopy can be complementary nondestructive method for the evaluation or to diagnosis of adhesive joints type coating-substrate.

## 5. References

- [1] CHAMBERS, J. K. and TUCKER, J. B.: *Bondline Analysis Using Swept-Frequency Ultrasonic Spectroscopy*. INSIGHT - Nondestructive Testing and Condition Monitoring, Vol. 41, No 3, 1999, pp. 151-155.
- [2] DEVEN, P. N. and CAWLEY, P.: *The Practical Application of Ultrasonic Spectroscopy for the Measurement of Cohesive Properties of Adhesive Joints*. NDT&E International, Vol. 25, 1992, No 2, pp. 65-75.
- [3] LETHICQ, M. and PERDRIX M.: *Automatic Discrimination Techniques for NDT of Metal-Ceramic Bonds*. NDT&E International, Vol. 24, 1991, No 6, pp. 307-311.
- [4] KRAUTKRAMER, J., KRAUTKRAMER, H.: *Ultrasonic Testing of Materials*. Springer-Verlag, Berlin, 1990.
- [5] OZIMEK, E.: *Theoretical basis of analysis of spectra signals (in Polish)*. PWN, Poznan, 1985.
- [6] OBRAZ, J.: *Ultrasonounds in measuring technique (in Polish - translated from Czech)*. WNT, Warsaw, 1983.
- [7] JARMUZEK, M.: *An application of ultrasonic spectrum analysis for evaluation of substrate and coating condition in adhesive joints*. Thesis of PUT, Poznan, 2000.

Dana Sitányiová \*

## VPLYV DEZINTEGRAČNÝCH METÓD NA VÝSLEDKY HUSTOMERNEJ SKÚŠKY

### THE INFLUENCE OF DISINTEGRATION METHODS ON TEST RESULTS FOR ASSESSMENT OF THE SOIL PARTICLE SIZE DISTRIBUTION

Článok nadväzujúci na výskumnú úlohu je zameraný na vykonávanie hustomernej skúšky na určenie zrnitosti zeminy pre zeminy neobsahujúce zrná nad 2 mm. Niektoré časti skúšky vyzerať byt problematické a rôzne laboratória často získavajú rôzne výsledky. Príspevok sa zameriava na dokázanie skutočnosti, že rôzne metódy separácie zŕn majú podstatný vplyv na výsledok celej hustomernej skúšky a ukazuje, ako rôzne separačné metódy pôsobia na jednotlivé minerálne zrná spolu s pôsobením dispergačného činidla.

#### 1. Úvod

Skúška pre stanovenie zrnitosti zeminy je bežne používanou skúškou v geotechnickej laboratórnej praxi. Výsledky tejto skúšky je možné využiť pre ostatné geotechnické stanovenia a charakteristiky zemín, napr.: upresnenie výberu smerných normových hodnôt, orientačné stanovenie priepustnosti, namrzavosť podľa Schiebleho, aktivitu ílových minerálov, vhodnosť zeminového filtra pre malé vodné nádrže a pod.

Skúška sa môže vykonávať rôznymi spôsobmi v závislosti od veľkosti zŕn zeminy. Všeobecne sa pre zeminy, ktoré obsahujú zrná väčšie ako 2 mm, používa mokré alebo suché preosievanie a pre zeminy obsahujúce zrná menšie ako 2 mm hustomernej skúška a pipetová skúška. Pre iné typy zemín sa môžu použiť kombinované alebo iné metódy.

Článok nadväzuje na výskumnú úlohu – Fyzikálne a chemické vzťahy v systéme ílovitá frakcia – voda, na ktorej sa pracovalo v tomto roku na katedre geotechniky. Úloha bola zameraná na vykonávanie hustomernej skúšky pre určenie zrnitosti zeminy, ktorá neobsahuje zrná väčšie ako 2 mm. V laboratóriu boli testované viaceré vzorky a dve z nich, jedna z Martina a druhá z Lipovskej Ondrašovej boli podrobené úplnej a opakovanej analýze, vrátane mikroskopického pozorovania.

The article pertinent to the research activity focuses on the hydrometer test performed for assessment of the soil particle size distribution for soils not containing the particles of size over 2 mm. Some stages of the test seem to be problematic, and various laboratories often obtain different test results. The contribution is directed to prove the fact that various methods of particles separation substantially influence the result of a whole hydrometer test and trace how various separation methods effect the individual mineral particles together with dispersing agent.

#### 1. Introduction

The test for assessment of the soil particle size distribution is in common use in the geo-technical laboratory praxis. The results of the test can be utilized for other geo-technical determinations and characteristics of soils e.g.: choice specification of norm values, informative assignation of permeability, frost susceptibility by Schieble, activity of clay minerals, applicability of a soil filter for little dams, etc.

The test can be performed in different ways in dependence on the size of the soil particles. Generally the wet or dry sieving is used for the soils containing particles of a size over 2 mm, hydrometer test and pipette test for the soils containing particles of a size under 2 mm. For other type of soils combination method, or other method can be used.

The article relates to the research activity – Physical and chemical relations in a water clay suspension system, which have been carried out at the department of geotechnique this year. The research focused on the hydrometer test performed for assessment of the particle soil distribution for soils not containing particles of a size over 2 mm. Several samples of soils were tested in the laboratory and two of them, one from Martin and another from Lipovská Ondrašová, were completely and frequently analyzed, included a microscopic observation.

\* Mgr. Dana Sitányiová

Faculty of Civil Engineering, Department of Geotechnique, University of Žilina, Komenského 52, 010 26 Žilina,  
Tel: ++421-41-7634818, E-mail: dasit@fstav.utc.sk

## 2. Teória sedimentácie

Teória sedimentácie je založená na skutočnosti, že väčšie častice sa v suspenzii usadzujú rýchlejšie ako malé, za predpokladu, že všetky častice majú podobný tvar a hustotu [2]. Ak sú zrná približne guľovitého tvaru, vzťah medzi konečnou rýchlosťou -  $V$  a priemerom zrna -  $D$  je daný Stokesovým zákonom.

$$V \propto D^2 \quad (1)$$

Hoci ílovité zrná nemajú guľovitý tvar, aplikovanie Stokesovho zákona je dostatočne realistické pre väčšinu praktických prípadov. V zmysle Stokesovho zákona je konečná rýchlosť guľovitej častice klesajúcej v kvapaline daná vzťahom:

$$V = \frac{D^2 g(\rho_S - \rho_L)}{18\eta} \quad (2)$$

kde  $D$  = priemer zrna;  $\rho_S$  = hustota hmoty pevných zrn;  $\rho_L$  = hustota hmoty kvapaliny;  $\eta$  = dynamická viskozita kvapaliny;  $g$  = gravitačné zrýchlenie. V súlade s teóriou sedimentácie sú zrná rôznej veľkosti reprezentované ich konečnou rýchlosťou a približne ekvivalentnými priermi.

Počas hustomernej skúšky sa zrná nechajú usadzovať pod vplyvom gravitácie cez kvapalinový stĺpec vysoký 300 mm. Hneď, ako sa suspenzia domieša (čas  $t = 0$ ), sú všetky zrná rozptýlené po celej hĺbke suspenzie. Potom sa začnú usadzovať na dno. Ak predpokladáme, že zrná dosiahnu ich konečnú rýchlosť za krátky čas, po 10 sekundách každé zrno veľkosti hrubej prachovitej častice spadne 10 mm, stredne prachovitej častice 1 mm a jemne prachovitej častice 0,1 mm.

Po 30 000 sekundách (asi 8 hodín) všetky zrná vo veľkosti prachovitej častice dosiahnu dno a v suspenzii ostanú len zrná vo veľkosti ílovitých častíc. Z presných meraní vykonaných v známych časových intervaloch od začiatku sedimentácie je možné stanoviť zrnitosť zeminy. Prítomnosť hmoty pevných zrn môže byť stanovená pomocou vzorkovania zo stanovenej hĺbky (v pipetovej analýze), alebo meraním hustoty suspenzie pomocou hustomeru (hustomerová skúška).

## 3. Popis hustomernej analýzy

V tejto metóde sa na meranie hustoty suspenzie zeminy vo vode používa v rôznych časových intervaloch hustomer špeciálneho tvaru. Postup skúšky a reagenty sú uvedené v tabuľke 1.

Kompletná skúška sa obvykle vykonáva nasledovne:

1. *Výber a príprava*: z reprezentatívnej časti celej vzorky by sa mala vybrať primerane

The test stages and used reagents

Test procedural stages:	Reagents
Selection and preparation of the test specimen	Distilled water
Pretreatment for organic or calcareous matter	Hydrogen peroxide [20 volume solution]
Separation and dispersion	Dispersant solution
Wet sieving to 0.125 mm sieve	Hydrochloric acid
Hydrometer test	[ $c = 1 \text{ mol/l}$ ]
Calculation and result presentation	

Tab. 1

In this method a density hydrometer of special design is used to measure the density of a soil suspension in water at various time intervals. The test procedure and reagents are shown in the Table 1.

The complete test is usually performed as follows:

1. *Selection and preparation*: the appropriate size of specimen from representative part of

## 2. Sedimentation theory

The theory of sedimentation is based on the fact that large particles of suspension settle more quickly in liquid than small particles, assuming that all particles have similar shapes and densities [2]. If the particles are approximately spherical, Stokes' Law gives the relationship between a terminal velocity -  $V$  and a particle diameter -  $D$ .

$$V \propto D^2 \quad (1)$$

Although clay particles are not of a spherical shape, the application of Stokes' Law is sufficiently realistic for most practical purposes [2]. According to Stokes' Law, the terminal velocity of a spherical particle falling in fluid is given by:

$$V = \frac{D^2 g(\rho_S - \rho_L)}{18\eta} \quad (2)$$

Where  $D$  = diameter of particle;  $\rho_S$  = mass density of the solid particle;  $\rho_L$  = mass density of the fluid;  $\eta$  = dynamic viscosity of the fluid;  $g$  = acceleration due to gravity. According to theory of sedimentation, the particles of different size are represented by their terminal velocities and approximate equivalent diameters.

In a hydrometer sedimentation test the particles are allowed to settle under gravity through the water over 300 mm deep. Immediately after the suspension has been shaken up (time  $t = 0$ ), all particles are distributed throughout the depth of suspension. Then the particles started to settle to the bottom. If we assume that a particle reaches its terminal velocity within a very short time, after 10 s the coarse silt particles have each fallen 10 mm, the medium silt particles 1 mm and the fine silt particles 0.1 mm.

After 30 000 s (about 8 h) silt particles of all size have reached the bottom, leaving only the particles of clay size in suspension. From certain measurements made at known time intervals from the start of sedimentation, the distribution of particle sizes can be assessed. The mass of solid particles present can be determined by sampling from a specified depth (as in the pipette test) or by measuring the density of suspension with a hydrometer (the hydrometer test).

## 3. Description of the hydrometer analysis

- veľká vzorka (zároveň sa musí stanoviť vlhkosť zeminy pre výpočet hustoty suspenzie).
2. *Predpríprava*: táto fáza nie je potrebná vždy. Predpríprava v prípade prítomnosti organickej hmoty je vhodná pre organické zeminy a vykonáva sa pomocou oxidácie peroxidom vodíka. Predpríprava v prípade uhličitanovej hmoty s kyselinou chlórvoďíkovou zabezpečuje oddelenie jednotlivých zŕn, pretože vápnné prímеси môžu pôsobiť ako cementačné činidlo. Používa sa pri vápnných zeminách.
  3. *Separácia a disperzia*: pri separácii na jednotlivé zŕna sa môžu použiť alternatívne postupy. Pred separáciou sa pripraví vodná suspenzia a do nej sa pridá dispergačné činidlo. Potom by sa suspenzia mala nechať dispergovať najmenej 24 hodín.
  4. *Preosievanie*: pripravená dispergovaná suspenzia sa preoseje cez 0,125 mm sito a prenesie sa do odmerného valca, kde prebieha samotná hustomerná skúška.
  5. *Hustomerná skúška*: keď suspenzia dosiahne izbovú teplotu, zamieša sa v odmernom valci. Hneď po domiešaní sa musí začať s odčítavaním na hustometri v rôznych časových intervaloch.
  6. *Výpočet a prezentácia výsledkov*: namerané hustomerné čítania sa vložia do počítača a sú vyhodnotené bežne používaným softvérom, v našom prípade pomocou programu Soilab. Výsledkom sú krivky zrnitosti, ktoré znázorňujú percentuálne zastúpenie zŕn zeminy.

Druhá a tretia fáza vyzerá byť problematická, pretože vykonanie týchto fáz je úplne závislé od osoby, ktorá vykonáva skúšku. Ona vyberá vhodné dispergačné činidlo, jeho množstvo, separačnú metódu a trvanie jednotlivých krokov. Tento fakt veľmi vplyva na výsledok skúšky a týmto spôsobom viaceré laboratóriá získavajú rôzne výsledky. Z tohto dôvodu sa výskumná úloha zameriava na nájdenie optimálnej metódy pre stanovenie zrnitosti zeminy. Konkrétne na druhý a tretí krok skúšky.

#### 4. Teória disperzie

Systém zeminy a destilovanej vody reprezentuje *disperzný systém* dvoch fáz. V našom prípade je pevná fáza reprezentovaná fázou zeminy (dispergovaná fáza - disperzum) a destilovaná voda zastupuje disperzné prostredie. Tento typ disperzného systému sa nazýva suspenzia a môžeme ju zaradiť medzi systémy lyofóbneho typu. *Lyofóbne sóly* sú charakteristické nízkou príťažlivosťou medzi dispergovanou fázou a disperzným prostredím. Z hľadiska stability a rozpúšťania koloidných častíc sú dôležité ióny adsorbované na koloidných časticiach. Z tohto dôvodu sú lyofóbne sóly veľmi citlivé na prídanie elektrolytov, ktoré znižujú veľkosť iónového náboja vo sfére medzi dvoma fázami. Proces, kedy sa koloidné častice zrážajú, je nazývaný *koagulácia*. Proces opačný, keď sa koagulované agregáty premieňajú na koloidné častice, sa nazýva *disperzia*. Na stabilitu koloidnej častice vplyva mnoho faktorov, ale najdôležitejším je existencia elektrického náboja. Preto sa pri koagulácii alebo disperzii používajú metódy, ktoré ovplyvňujú elektrický náboj častíc. Najpoužívanejšou metódou na ovplyvnenie elektrického náboja je použitie *disperzných činidiel*.

- whole sample should be chosen (hereby, it is necessary to assign the soil moisture for the calculation of suspension density).
2. *Pretreatment*: this stage is not necessary every time. Pretreatment for organic matter is suitable for organic soils and it's provided with oxidation process with hydrogen peroxide. Pretreatment for calcareous matter with hydrochloric acid is required for separation of individual grains, because the calcareous compounds could act as a cementing agent. It's used for calcareous soils.
  3. *Separation and dispersion*: for separation of the individual particles alternative procedures can be used. Before separation the water suspension is prepared and dispersing agent is added into suspension. Then the suspension should be allowed to disperse at least 24 hours.
  4. *Sieving*: prepared dispersed suspension is sieved through the 0.125 mm sieve and transferred to a cylinder, where the hydrometer test is realized.
  5. *Hydrometer test*: when suspension reached the room temperature, it's shaken in the cylinder. After stirring subsequently the readings of hydrometer at various intervals of time must be taken.
  6. *Calculation and result presentation*: measured readings are inserted into a computer and evaluated with a commonly used software, in our case with the Soilab program. The curve, which presents the per-cent representation of the soil particle sizes is obtained.

The stages number 2 and 3 seem to be problematic, because of the fact that the execution of these stages is absolutely dependent on a person who performs the test. S/he chooses a suitable kind of a dispersing agent, its amount, separation method and duration of single stages. This has a great influence on the test results and, in this way, various laboratories obtain different tests results. Because of that fact, the research activity aimed at finding an optimal method for the assessment of a soil particle size distribution. Concretely, it focuses on the second and third test stages.

#### 4. Dispersion theory

The system of soil and distilled water represents a *dispersed system* of two phases. In our case, the soil represents the solid phase (dispersed phase) and distilled water represents a dispersed medium. This type of a dispersed system is called suspension and it can be tabled among lyophobic types. *Lyophobic sols* are characteristic by a low attraction between a dispersed phase and a dispersed medium. The ions adsorbed on colloidal particles are important for stability and dissolution of colloidal particles. On account of that, lyophobic sols are very responsive to the adding of electrolyte, which lower the value of an ion charge in the sphere between two phases. The process, when the colloidal particles are flocked is called *coagulation*. The opposite process, when the flocked aggregates are turned to colloidal particle is known as *dispersion*. Many factors influence the stability of a colloidal particle, but the existence of an electrical charge is the most important. Therefore, the methods, which have impact on the electrical charge of the particle are used to coagulating or dispersion. The most common way to affect the charge is the use of *dispersing agents*.

## 5. Popis skúšok

V laboratóriu katedry geotechniky boli testované vzorky z dvoch lokalít, jedna z *Martina* (vzorka 1) a druhá z *Liptovskej Ondrašovej* (vzorka 2). Obe vzorky boli získané zo sedimentárneho ložiska (z vrchnej povrchovej vrstvy), kde sa ťaží materiál (paleogénna vápnito-ílovitá bridlica a neogénny vápnitý íl) pre tehliarsky priemysel. Najčastejšie sa vyskytujúcimi minerálmi sú: kremeň, kalcit, dolomit, pyrit, limonit, illit, kaolinit a montmorillonit. Vzorka 1 tiež obsahovala vápnité úlomky fosílií a uhoľnú drvinu (pigment). Vykonali sa nasledovné procedúry:

Primerané množstvo prirodzene vlhkej skúšobnej vzorky (asi 40 g) sa zalialo destilovanou vodou s dispergačným činidlom, ručne sa niekoľkokrát zamiešalo a nechalo sa dispergovať cez noc (24 hodín). Potom sa vzorka rozdrúžila rôznymi dezintegračnými metódami (mixovaním s vysokootáčkovým ponorným mixérom, vibračným miešaním s ultrazvukovým dezintegrátorom UZD-300 od firmy Belson Levice, varením a mletím s vibračným mlynom VM4 – s frekvenciou 50 Hz). Neskôr sa takto pripravená rozptýlená suspenzia preosiala cez 0,125 mm sito a preniesla do valca na sedimentačný test. Výsledky hustomerných čítaní sa vložili do počítača a vyhodnotili softvérom Soilab. Určenie hodnoty *zrnitosti zeminy* pre testované vzorky a získané *krivky* reprezentujú výsledky hustomernej skúšky (viď graf 1 - 4).

Cieľom našej výskumnej úlohy bolo dokázať, že prídanie roztokov *rôznych dispergačných činidiel a rôzne metódy separácie* majú vplyv na rozdrúženie zŕn zeminy. Na základe predchádzajúcich experimentov s rôznymi: antikoagulačnými činidlami, ich koncentraciami, množstvom vzorky a pod., bolo rozhodnuté použiť nasledujúce *antikoagulačné činidlá*:

- štandardne používaný antikoagulačný roztok, ktorým je 33 g hexametafosforečnanu sodného a 7 g uhličitanu sodného v 1 litri destilovanej vody (ďalej – H),
- roztok vodného skla 18 ml v 1 litri destilovanej vody (ďalej – WG).

Antikoagulačný roztok H sa používa najmä pre vápnité zeminy a patrí medzi aktívne antikoagulačné činidlá. Antikoagulant WG patrí medzi ochranné typy [3]. Vzorky boli testované s dvoma koncentraciami dispergačného roztoku (15 a 20 ml na liter). Ako *dezintegračné metódy* boli použité:

- mixovanie (30 s, 60 s, 120 s, 5 min, 15 min),
- mletie (60 s),
- varenie (1 h, 2 h),
- ultrazvukové vlnenie (120 s, štyri stupne intenzity 600 – 1200 W.dm<sup>-3</sup>) kombinované s mixovaním (120 s).

Výskumná úloha bola orientovaná na preukázanie faktu, že rôzne metódy separácie zŕn majú podstatný vplyv na výsledok celej hustomernej skúšky a objasniť ako jednotlivé separačné metódy vplyvajú na jednotlivé minerálne zrná spolu s pôsobením antikoagulantu. Z tohto dôvodu boli počas skúšky odoberané malé kvapky suspenzie na mikroskopické sklíčka (trikrát: po dispergácii cez noc, po separácii a po preosiati), aby sa demonštroval vplyv rôznych druhov antikoagulantu a metód rozdrúžovania.

## 5. Test Description.

The samples from two locations were tested in the laboratory of Geotechnique department, one from *Martin* (sample 1) and another one from *Liptovská Ondrašová* (sample 2). Both samples were obtained from the deposits (from upper layer-surface), where the raw material (paleogenic calcareous clay shale and neogenic calcareous clay) is exploited for bricks production. The most frequent minerals are: quartz, calcite, dolomite, pyrite, limonite, illite, kaolinite, montmorillonite. Sample 1 contains also calcareous tests of fossils and coal slack. The following procedures were performed.

An appropriate size of natural moist test specimen (about 40 g) was over-flooded with a dispersing agent solution, stirred manually several times and allowed to disperse overnight (24 hours). Then it was separated by various separation methods (mixing with high-speed stirrer-mixer; vibro-stirring with ultrasonic waving with disintegrator UZD-300 – by Belson Levice, boiling and milling with vibrating mill VM4 – frequency 50 Hz). Later the prepared dispersed suspension was sieved through the 0.125 mm sieve and transferred to a cylinder for a sedimentation test. The results of hydrometer readings were put into the computer and evaluated by Soilab software. The determination of *the soil particle size distribution* for tested samples and obtained *curves* represent the results of the hydrometer test (see Figures 1-4).

The aim of our research activity was to prove that the adding of *various dispersing agent solution and various methods of separation influence* the soil particle separation. On the basis of previous experiments with a different: dispersing agent, concentration of dispersing solution, size of specimen, etc., it was decided to use the following *dispersing agents*:

- standard used dispersant solution that is, 33g of sodium hexametafosphate and 7 g of sodium carbonate in distilled water to make 1 liter (further H),
- water glass solution 18 ml in distilled water to make 1 liter (further WG).

Dispersant solution H is used especially for calcareous soils and it belongs to active dispersants. WG is a protective type of dispersant [3]. The samples were tested with two strengths of dispersant solution (15 and 20 ml per liter). The following *separation methods* were used:

- mixing (30 s, 60 s, 120 s, 5 min, 15 min),
- milling (60 s),
- boiling (1 h, 2 h),
- ultrasonic waving (120 s, four rate level 600 – 1200 W.dm<sup>-3</sup>) combined with mixing (120 s).

The research activity was directed to prove the fact that various methods of particle separation have substantial influence on the results of the whole hydrometer test and trace how various separation methods effect the individual mineral particle together with a dispersing agent. On this account during the test the small drop of suspension was transferred onto the object plates (three times: after disperse overnight, after separation and after sieving) to demonstrate the influence of various kinds of dispersants and

Sklička sa pozorovali mikroskopom MEOPTA D v prechádzajúcom svetle pri 160 násobnom zväčšení (objektovom poli mikroskopu 0,82 mm a rozlišovacej schopnosti 2  $\mu\text{m}$ ). Vzorky sa testovali aj na obsah uhličitanov (hlavne  $\text{CaCO}_3$ ). Vzorka 1 obsahovala 25,476 % a vzorka 2 obsahovala 29,501 % uhličitanových zložiek. Z tohto dôvodu boli obe vzorky podrobené predpríprave pre prítomnosť uhličitanovej hmoty a vzorka 1 (obsahujúca uhoľný pigment) bola testovaná a pripravená aj pre prítomnosť organickej hmoty. Kvôli klasifikovaniu typu zeminy podľa STN-73 1001 (USCS) sa vykonali aj skúšky na určenie medze tekutosti a plasticity. Počas skúšky boli zachované štandardné podmienky a boli sledované hodnoty teploty a pH.

## 6. Výsledky

Pre vzorku 1 sa urobilo 17 hustomerných skúšok. Výsledky skúšok sú znázornené krivkami zrnitosti zeminy (viď grafy 1 - 4 a tabuľky 2 - 5).

methods of separation. The object plates were observed through a MEOPTA D microscope in crossing light by zooming 160x (object field of microscope 0.82 mm, distinctive capacity 2  $\mu\text{m}$ ). The samples were tested for volume of calcareous compounds (mainly  $\text{CaCO}_3$ ) too. The sample 1 contained 25.476 % and sample 2 contained 29.501 % of calcareous compounds. For that reason both samples were deferred to pretreatment for calcareous matter and sample 1 (containing coal slack) was tested and prepared also for organic matter. The tests for liquid and plastic limits were done to classify the type of soil by STN-73 1001 (USCS) too. During the hydrometer test the standard conditions were saved, and the temperature and pH noted.

## 6. Results

The hydrometer tests in total number of 17 were carried out for sample 1. The results of the test are presented by curves of the soil particle size distribution (see Figures 1 - 4 and Tables 2 - 5).

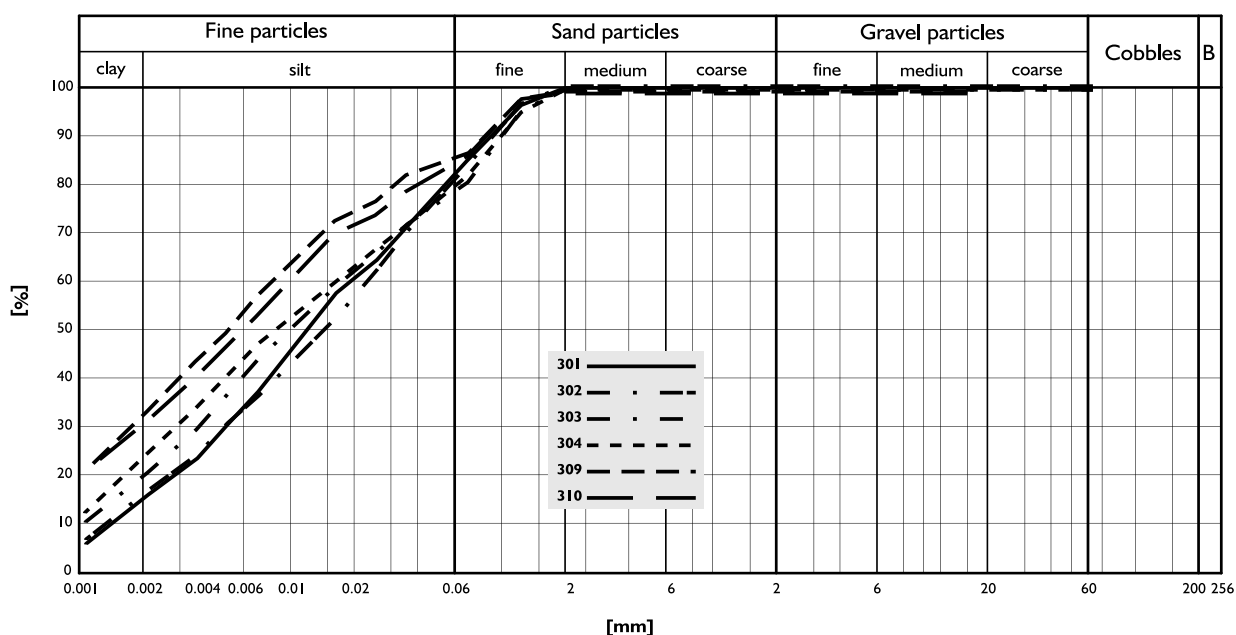

Fig. 1. The curves of the soil particle size distribution for sample 1

Volume of the particles of clay size for single curves

Tab. 2

Sample 1 Dispersing agent - water glass (WG), separation method - mixing			
Curve number	Dispersing agent concentration (ml per liter)	Time of separation (sec, min)	Volume of the particles of clay size (%)
301	15	30 sec	15
302	20	30 sec	16
303	15	60 sec	19
304	20	60 sec	23
309	20	5 min	32
310	20	15 min	30

Prvá skupina kriviek pre vzorku 1 reprezentuje antikoagulačné činidlo vodné sklo a ako separačná metóda bolo použité mixovanie. Je zrejme, že zmena koncentrácie antikoagulačného roztoku z 15 na 20 ml nemá podstatný vplyv na obsah ílovitých zŕn (krivky 301, 302, 303, 304), ale predĺženie doby mixovania zvyšuje obsah ílovitých zŕn zo 16 % na 32 %. Mikroskopické pozorovanie pre túto skupinu skúšok je znázornené na obrázku 1 a 4. Fotografia 1 znázorňuje 60 sekundové mixovanie. Tento mikroskopický preparát bol použitý ako štandard pre ostatné. Fotografia 4 znázorňuje 15 minútové mixovanie. Zrná sú úplne oddelené. Medzi 5 minútovým a 15 minútovým mixovaním nie je podstatný rozdiel, percentuálne zastúpenie ílovitých častíc je 32 % a 30 %.

The first group of curves for sample 1 represents dispersing agent water glass and the mixing was used as a separation method. It is obvious that the change of a dispersant concentration from 15 to 20 ml doesn't essentially affect the volume of clay particles (the curves 301, 302, 303, 304), but the extension of the mixing increases the clay particle volume from 16 % to 32 %. The microscope observation for this group of tests is presented on the Photos 1 and 4. Photo 1 represents a 60 seconds mixing. This microscopic preparation was used as standard for others. Photo 4 represents a 15 minutes mixing. The particles are completely separated. There is no substantial difference between 5 minutes and 15 minutes mixing, the percent volume of the clay particle is 32 and 30 %.

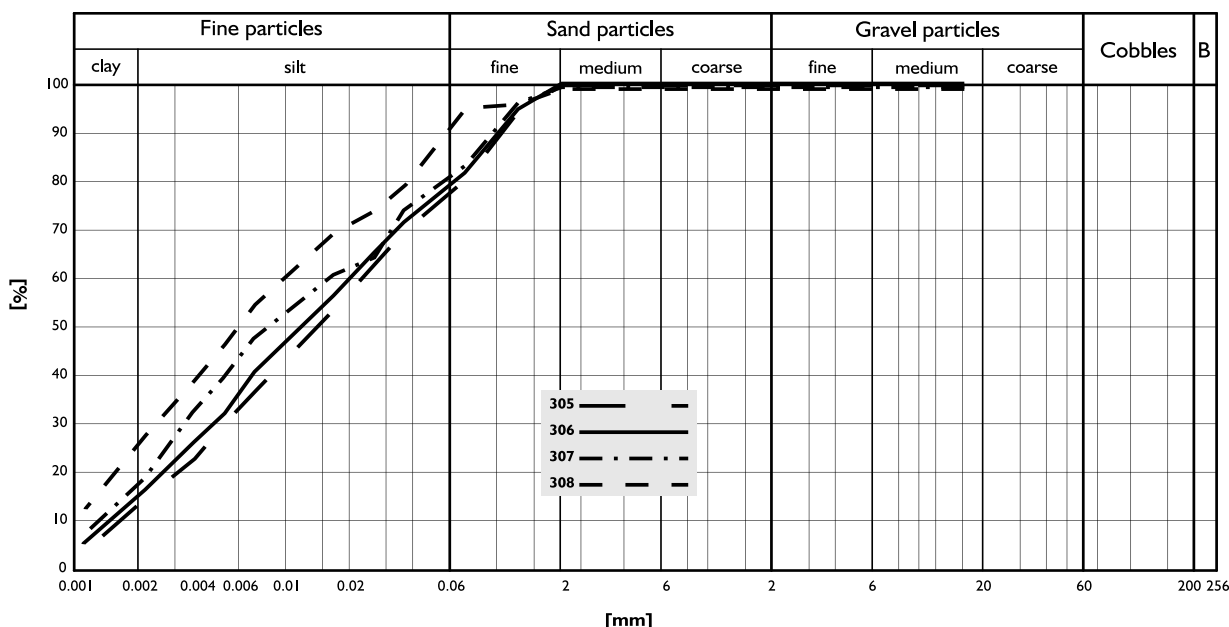

Fig. 2. The curves of the soil particle size distribution for sample 1.

Volume of the particles of clay size for single curves

Tab. 3

Sample 1 Dispersing agent - water glass (WG) and hexametaphosphate (H), Separation method - boiling (BOI), milling (MIL)			
Curve number	Dispersing agent concentration (ml per liter)	Time of separation (sec, hours)	Volume of the particles of clay size (%)
305	15 WG	2 hours BOI	13
306	20 WG	2 hours BOI	15
307	15 WG	60 sec MIL	17
308	15 H	60 sec MIL	26

Druhá skupina kriviek reprezentuje separačné metódy varenie a mletie. Pri varení koncentrácia dispergačného roztoku nie je dôležitá (13 % a 15 % ílovitých zŕn). Nárast obsahu ílovitých častíc z 15 % pri použití WG na 26 % pri použití H je zjavný pri mletí. Tento fakt môže byť zapríčinený prílišným rozdrvením niektorých minerálov alebo rôznym účinkom dvoch typov antikoagulantov.

The second group of curves represents boiling and milling as separation methods. Concentration of dispersing agent is not important with boiling (13 % and 15%). The increase of the clay particle volume from 17 % by using WG to 26 % by using H is clear with milling. This fact could be caused by too much crushing of some minerals particles, or by different actions of two types of dispersing agents.

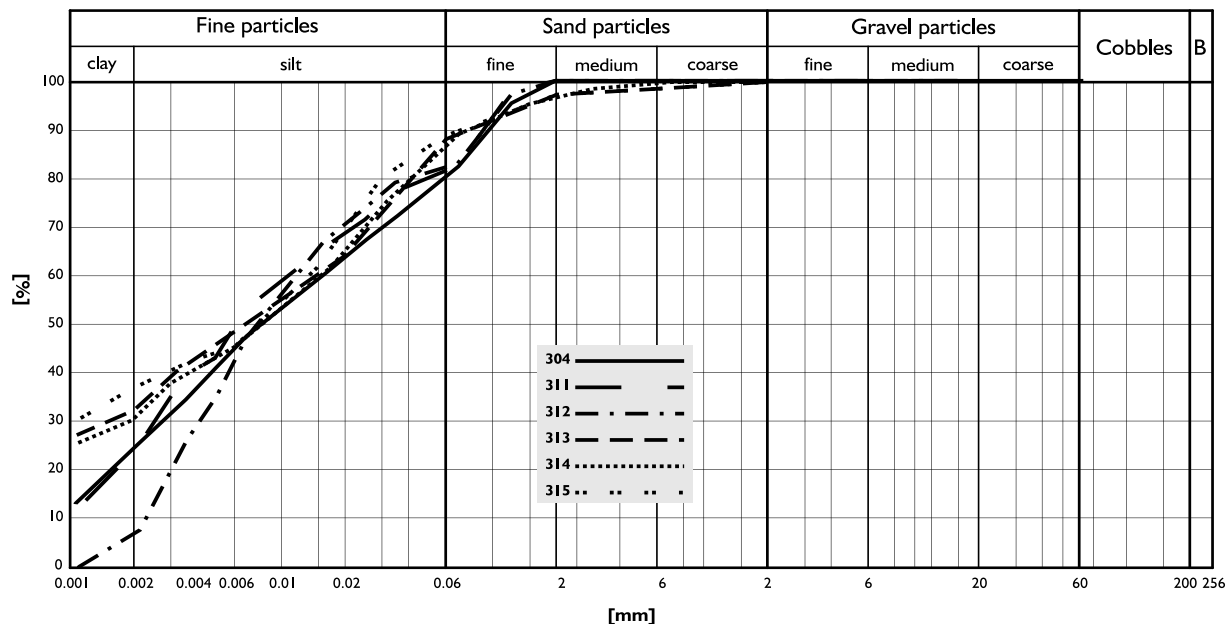

Fig. 3. The curves of the soil particle size distribution for sample 1.

Volume of the particles of clay size for single curves

Tab. 4

Sample 1 Dispersing agent - water glass (WG) and hexametaphosphate (H), Separation method - mixing (MIX), ultrasonic waving (intensity - I2,I3,I4) with mixing (SS/MIX) Pretreatment with H <sub>2</sub> O <sub>2</sub> and HCl				
Curve number	Pretreatment with HCl with H <sub>2</sub> O <sub>2</sub>	Dispersing agent concentration (ml per liter)	Time of separation (sec, min)	Volume of the particles of clay size (%)
304	-	20 WG	60 sec MIX	24
311	H <sub>2</sub> O <sub>2</sub>	20 WG	60 sec MIX	23
312	HCl	20 WG	60 sec MIX	7
313	-	20 H	2 min I2 SS/ 2 min MIX	32
314	-	20 H	2 min I3 SS/2 min MIX	30
315	-	20 H	2 min I4 SS/2 min MIX	37

Pri krivke 312 je viditeľný značný úbytok častíc pod 0,002 mm z 23 % na 7 %. Je to výsledok rozpustenia uhličitanových minerálov, napr. kalcitu, dolomitu atď. Krivka 311 znázorňuje test s predprpravou s H<sub>2</sub>O<sub>2</sub>. Tento spôsob predprpravy príliš neovplyvnil výsledok skúšky. Skúška bez predprpravy, ktorú znázorňuje krivka 304 bola vykonaná kvôli porovnaniu vplyvu chemickej predprpravy. Krivky číslo 313, 314, a 315 reprezentujú použitie separačnej metódy ultrazvukového vlnenia a mixovania. Vplyv intenzity vlnenia nebol preukázaný. V tomto prípade sa obsah ílovitých častíc pohybuje od 30 % do 37 %. Ultrazvukový prístroj bol zrejme nepresný, alebo táto kombinovaná metóda rozdzušovania nie je vhodná.

Všetky testy (pre vzorku 1) klasifikujú typ zeminy (podľa STN 73 1001) ako íl s vysokou plasticitou F8 CH a krivky nadobúdajú približne podobný tvar, ale percentuálny obsah ílovitej frakcie kolíše od 7 % do 37 %. Krivka 312 vyzerá dosť odlišne. V tomto prípade bola vzorka podrobená predprprave pre prítomnosť uhličitanov. Obsah ílovitých častíc je tu len 7 %. Mikroskopická kontrola ukazuje

The massive loss of the particles of size under 0.002 mm from 23 to 7 % is visible at curve 312. That is the result of the resolution of the calcareous minerals e.g. calcite, dolomite etc. The curve 311 illustrates the test with pretreatment with H<sub>2</sub>O<sub>2</sub>. This type of the pretreatment did not affect the test so much. The test without pretreatment represented by curve 304 was performed to compare the effect of chemical pretreatment. The curves number 313, 314, 315 present the usage of ultrasonic waving with mixing as a separation method. The influence of the waving intensity was not documented. The percent volume of clay particles varies from 30 to 37 %. The ultrasonic instrument seems to be uncertain, or this combination method of separation is not suitable.

All the tests (for sample 1) classify (by STN 73 1001) the soil type as clay with high plasticity F8 CH and the curves take comparatively similar form, but the per-cent volume of the clay particle size fluctuate from 7 to 37 %. Test 312 seems to be quite different. In this case the sample was deferred to pretreatment for calcare-

zmeny vo farebnosti a množstve pozorovaných zŕn (pozri fotografiu 3). Minerály, ktoré sa rozpúšťajú v HCl, sa samozrejme stratili. Napriek tomu, že chemická predpríprava vážne ovplyvňuje test, v mnohých prípadoch (priepustnosť, filtračná stabilita zemín a pod.) je potrebná a mali by sa vykonať dva paralelné testy, s predprípravou a bez nej. Podobné výsledky vykazujú testy 301, 302, 305, 306, 307 (okolo 15 % ílovitej frakcie) pri použití WG ako antikoagulantu a 30 sekundového mixovania, dvoch hodín varenia a 60 sekundového mletia. Mikroskopické pozorovanie neukazuje závažné zmeny (pozri fotografie 5, 6). Rozdiel je viditeľný medzi vzorkou pred a po preosiati (zrná sú po preosiati lepšie oddelené). Druhú skupinu podobných kriviek (20-26 % ílovitej frakcie) reprezentujú testy 303, 304, 308 a 311 pri použití WG a 60 sekundového mixovania; H a 60 sekundového mletia; WG a predprípravy s  $H_2O_2$  a 60 sekundového mixovania. Mikroskopické pozorovanie dáva podobné výsledky ako v predchádzajúcich prípadoch. Predpríprava z dôvodu prítomnosti organickej hmoty veľmi neovplyvňuje výsledok testu (pozri graf 3). Avšak rozdrvené zrná uhoľného pigmentu sa od ostatných zŕn dosť líšia (napr. nižšou hustotou a pevnosťou). Poslednú skupinu reprezentujú krivky 309, 310, 313, 314, 315, 316, 317 (28-37 % ílovitej frakcie). V týchto prípadoch bolo použité mixovanie trvajúce 5 a 15 minút a kombinácia ultrazvuku a 120 sekundového mixovania. Mikroskopické pozorovanie vykazuje slabý pokles obsahu väčších častíc a lepšie oddelenie všetkých zŕn (pozri fotografiu 4).

ous matter. The volume of the clay particles is only 7 % there. Microscope checking shows changes in color and amount of observed particles (see Photo 3). Minerals, which are soluble in HCl were, of course, lost. No matter how serious effect the chemical pretreatment has, in many cases (permeability, filtration stability of the soils etc.) is necessary, and parallel tests should be carried out without and with pretreatment. The tests 301, 302, 305, 306, 307 (about 15 % clay particles) give similar results by using WG as dispersing agent and mixing 30 s, boiling 2 h and milling 60 s. Microscope observation does not show significant changes (see Photos 5, 6). The divergence is visible between the sample before and after sieving (the particles are better discrete after sieving). A second group of similar curves (20-26 % clay particles) represents the tests 303, 304, 308 and 311 by using WG and 60 s mixing; H and 60 s milling; WG and  $H_2O_2$  pretreatment and 60s mixing. The microscope observation gives results similar to the previous case. The pretreatment for organic matter does not seem to have big effect on the test results (see Figure 3). But the coal slack particles are quite distinct from other mineral elements (e.g. lower density and resistance). The last group is represented by curves 309, 310, 313, 314, 315, 316, 317 (28-37 % clay particles). The mixing continued 5 and 15 minutes, and combination of ultrasonic vibro-stirring and 120s mixing was used in these cases. Microscope observation shows the slight fall of larger size particles and a better separation of all the particles (see Photo 4).

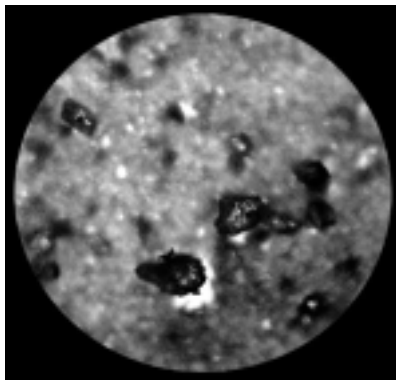

Photo 1. The standard microscopic preparation - WG, 60 seconds mixing.

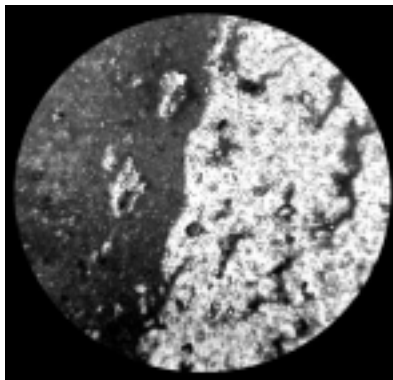

Photo 2. The microscopic preparation - WG,  $H_2O_2$  pretreatment, 60 seconds mixing.

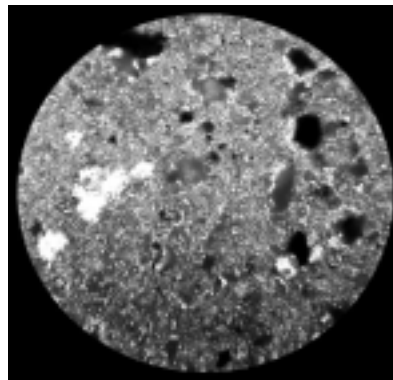

Photo 3. The microscopic preparation - WG, HCl pretreatment, 60 seconds mixing

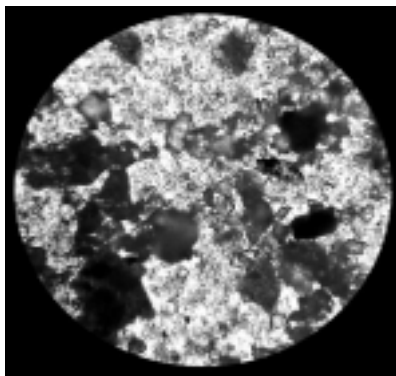

Photo 4. The microscopic preparation - WG, 15 minutes mixing.

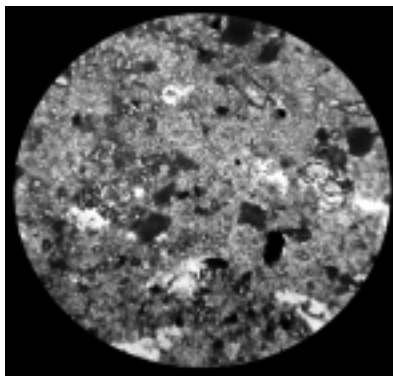

Photo 5. The microscopic preparation - WG, 2 hours boiling.

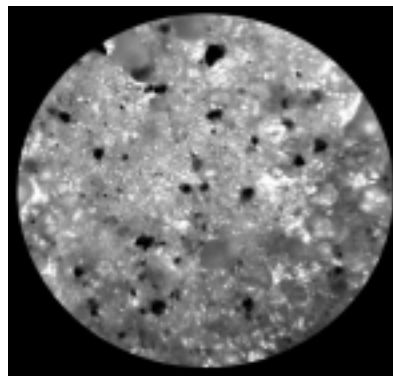

Photo 6. The microscopic preparation - WG, 60 seconds milling.

Pre vzorku 2 bolo urobených 22 testov. Výsledky sú porovnateľné s výsledkami pre vzorku 1.

For sample 2 the hydrometer tests in total number of 22 were done. The results are comparable to results of sample 1.

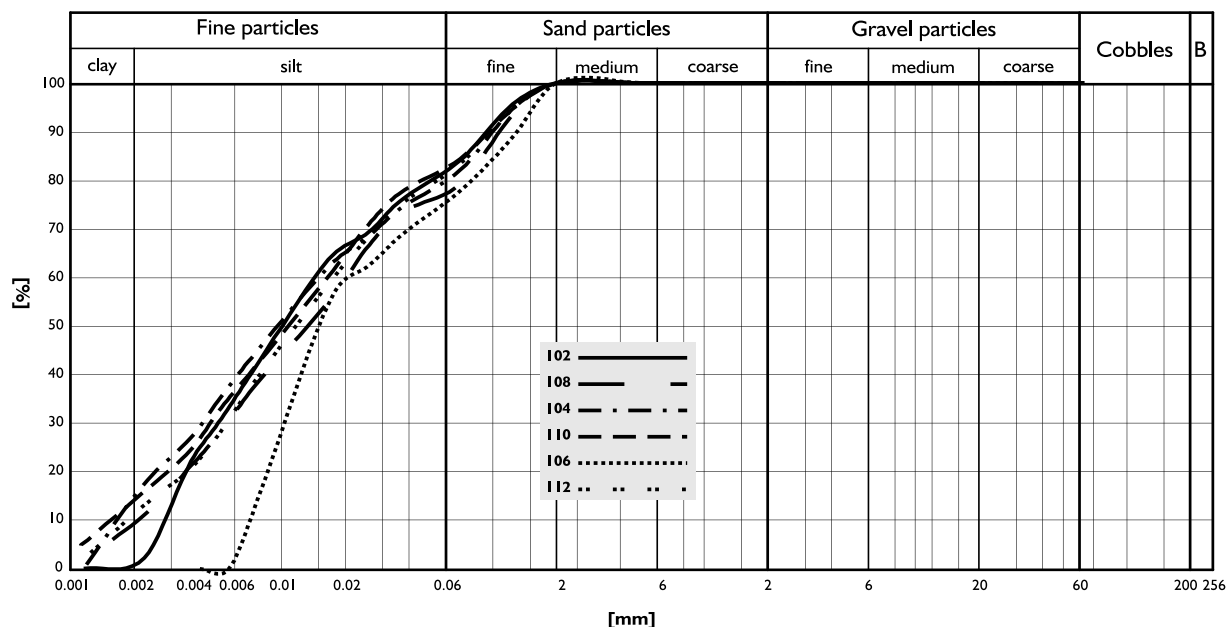

Fig. 4. The curves of the soil particle size distribution for sample 2

Volume of the particles of clay size for single curves

Tab. 5

Sample 2 Dispersing agent - water glass (WG), hexametaphosphate (H); Separation method - mixing, boiling			
Curve number	Dispersing agent concentration (ml per liter)	Time of separation (sec, min)	Volume of the particles of clay size (%)
102	20 H	30 sec MIX	2
108	20 WG	30 sec MIX	9
104	20 H	60 sec MIX	15
110	20 WG	60 sec MIX	14
106	20 H	1 hour BOI	0
112	20 WG	2 hours BOI	12

Tak, ako pri vzorke 1, podobné výsledky boli dokázané i pre vzorku 2 pri krivkách 104 a 110, naopak krivky 102 a 108 sú rôzne (2 % a 9 % ilovitej frakcie). To dokumentuje, že mixovanie trvajúce 30 sekúnd je ako separačná metóda nepostačujúce. Krivka 106 demonštruje, že hodinové varenie suspenzie je príliš krátke na separáciu, krivka je úplne zlá.

Ostatné krivky pre vzorku 2 boli podobné ako krivky pre vzorku 1. To je dôvod, prečo nie sú uvedené v tomto článku. Všetky skúšky (pre vzorku 2) klasifikujú (podľa STN-73 1001) typ zeminy ako íl so strednou plasticitou F6 CI. Percentuálny obsah ilovitej frakcie sa pohybuje od 0 do 36 %.

## 7. Zhrnutie

V zhrnutí môžu byť načrtnuté tieto závery:

Similar results were proved for sample 2 in the case of curves 104 and 110 as well as in the case of results for sample 1. By contrast the curves 102 and 108 are different (2 and 9 % clay particles). It manifests that the mixing as separation method in duration of 30 seconds is insufficient. The curve number 106 demonstrates that an hours boiling of the suspension is too short for separation, the curve is quite bad.

Other curves for sample 2 were similar to the curves for sample 1. That is why they are not presented in this article. All the tests (for sample 2) classify (by STN-73 1001) the soil type as clay with middle plasticity F6 CI. The percent volume of the clay particle size fluctuates from 0 to 36 %.

## 7. Conclusions

To sum up, the following conclusions can be drawn:

- rôzne metódy rozdrúžovania zŕn majú podstatný vplyv na výsledky hustomernej skúšky, hlavne na množstvo ílovitých častíc.
- vplyv *chemickej predprípravy* v prípade uhličitanovej hmoty bol preukázaný, ale v opodstatnených prípadoch by mala byť táto predpríprava napriek tomu vykonaná, napr.: pri určovaní vhodnosti zeminy pre zeminový filter pre skládky, naopak agregátovú štruktúru je vhodné zachovať v prípade stanovovania šmykovej pevnosti zemín. *Predpríprava v prípade organickej hmoty nemá veľký vplyv* (oxidácia trvala asi 1,5 dňa) na výsledok testu.
- *mikroskopické pozorovanie neukazuje masívny úbytok väčších zŕn* alebo viditeľný nárast obsahu malých častíc pri použití alternatívnych metód separácie, dokonca ani v prípade 15 minútového *mixovania* (táto doba je navrhovaná K. H. Headom v Manual of soil laboratory testing [2]) častice uhoľnej drviny s nízkou pevnosťou nie sú príliš porušené, tento efekt bol viditeľný len po mletí.
- ako *problematická časť* stanovenia sa javí *mikroskopické pozorovanie*; pri rozlišovacej schopnosti 2  $\mu\text{m}$  je ideálne pozorovanie nemožné. Z tohto dôvodu boli pozorované a počítané zrná vo veľkosti 5,5  $\mu\text{m}$  a 2,525  $\mu\text{m}$ .
- kvôli *štatistickému vyhodnoteniu* je potrebné vykonať *väčší počet testov*.

Z výsledkov testov vyplýva, že správna príprava vzorky zeminy pre hustomernú skúšku je veľmi dôležitá. Vhodný typ antikoagulantu a jeho dávkovanie je možné vybrať na základe predošlých skúseností. Použitie rôznych metód rozdrúžovania sa zdá byť komplikovanejšie. Skúšky ukazujú, že mixovanie po dobu 60 sekúnd až 5 minút je najvhodnejšia separačná metóda pre tento typ zeminy. Optimálny čas mixovania sú dve minúty. Výhodou tejto metódy je aj jej jednoduchosť. Dezintegrácia pomocou varenia a mletia sa zdá byť nevhodná. Dve hodiny varenia sú príliš dlhé a neefektívne a mletie môže poškodiť zrná s nižšou pevnosťou (pozri fotografiu 6). Výsledky pri použití kombinácie mixovania a pôsobenia ultrazvuku nie sú jednoznačné. Mohli byť spôsobené chybou prístroja. Samozrejme, pri určovaní zrnitosti zeminy je možné použiť i moderné prístroje. Laserový analyzátor veľkosti zŕn alebo fotosedimentačný prístroj sú tiež použiteľné. Výhodou týchto metód je ich jednoduchosť a doba realizácie a nevýhodou je hlavne malé množstvo vzorky (vzorka nie je reprezentatívna) [4]. Preto je v súčasnosti použitie hustomernej skúšky v našej laboratórnej praxi najrozšírenejšie. Na základe predchádzajúcich záverov a berúc na vedomie výskumné aktivity známych autorov sa zdá, že *zjednotenie laboratórnych skúšok a vypracovanie normy pre určovanie zrnitosti zeminy* bude v budúcnosti nevyhnutné.

- *Various methods of particle separation have substantial influence on the results* of a hydrometer test, mainly on the mass of clay particles.
- *The effect of pretreatment for calcareous matter* in case of calcareous soil was proved, but this type of pretreatment should be done in relevant matter e.g. applicability of the soil filter for the dumps, by contrast the conservation of soil aggregate structure is desirable in the case of assessment of shear strength of soil. *Pretreatment for organic matter did not show big influence* (the oxidation came off about 1.5 day) on the test results.
- *Microscopic observation did not show massive reduction of larger particles* or visible increase of the small particles volume by using alternative methods of separation, *even in the case of 15 min mixing* (this time is suggested by K.H. Head in Manual of soil laboratory testing [2]) the particles of coal slack with lower resistance were not broken too much, this effect was visible only after milling.
- *Problematic part* of the assessment seems to be *microscopic observation*; by distinctive capacity 2  $\mu\text{m}$  the ideal observation is impossible. For that reason the particles of size 5.5  $\mu\text{m}$  and 2.525  $\mu\text{m}$  were observed and counted.
- *A larger number* of the tests is necessary for statistic evaluation.

The results of the tests show the fact that the correct preparation of the soil specimen for a hydrometer test is very important. A suitable type of dispersing agent and its dosing can be chosen for various types of soils on the basis of previous experiences. The use of different separation methods seems to be more complicated. The tests showed that 60 seconds – 5 minutes mixing is the most suitable method for this type of soil. The optimal time of mixing is 2 minutes. The advantage of this method is its simplicity. Disintegration through boiling and milling does not seem to be convenient. Two hours boiling is too long and not effective and milling can damage the particles of low resistance (see Photo 6). The results of the combining mixing and ultrasonic waving are not clear. They could be incurred by on apparatus disorder. Of course, the test for assessment of the soil particle distribution can be carried out with the help of more modern instrumentation. The laser analyzer of the particles sizes, or photo settling apparatus could be used too. The advantages of these methods are simplicity and rate of realization and main disadvantage is the very small amount of specimen (the specimen is not representative) [4]. Therefore the use of hydrometer test is a dominant method in our laboratory praxis at present. On the basis of foregoing conclusions and mind the research activities of the known authors *the unification of soil laboratory testing and elaborating of standard* for assessment of the particle soil distribution seems to be inevitable in future.

## 8. Literatúra – References

- [1] Research team: *Metodiky laboratorných zkoušek v mechanice zemin a hornin*. Český geologický úřad, Praha 1987, 17-47.
- [2] HEAD, K. H.: *Manual of soil laboratory testing*. Pentech Press Limited, London 1992, 201-233.
- [3] KLUKANOVÁ, A.: *Faktory ovplyvňujúce kvalitu laboratórnych skúšok*. Rigorózná práca. PRIF UK, Bratislava 1980.
- [4] KIŠOVÁ, M., ADAMCOVÁ, R.: *Obsah ílovitej frakcie – problematický bod posúdenia vhodnosti zeminy do minerálnych tesnení skládok odpadu*. Zborník referátov z 2. konferencie Geológia a životné prostredie, Bratislava 2001, 98-101.

Janka Šestáková – Milan Mikšík \*

## EKOTECHNOLÓGIE PRI OPRAVÁCH KONŠTRUKCIE PODVALOVÉHO PODLOŽIA

### ECOTECHNOLOGIES FOR THE RECONSTRUCTIONS OF RAILWAY SUBGRADE CONSTRUCTION

*V súčasnosti sa v spojení s modernizáciou železničnej siete na našom území dostáva do popredia otázka trvalej stability geometrickej polohy koľaje. Táto je podmienená dodržaním predpísanej únosnosti celej konštrukcie podvalového podložia. Preto sa zriaďujú konštrukčné vrstvy, ktoré sa podieľajú na celkovom zvýšení jeho kvality.*

*Stavebná a prevádzková činnosť železničnej dopravy musí byť riadená s ohľadom na pravidlá ochrany životného prostredia. Ich rešpektovanie je dosiahnuteľné využívaním recyklovaných materiálov ale aj technológií, ktoré čo najviac sústreďujú pracovné činnosti priamo do osi koľaje.*

#### 1. Úvod

Kvalita klasickej konštrukcie jazdnej dráhy s koľajou uloženou v koľajovom lôžku, najmä stabilita geometrickej polohy koľaje, je závislá predovšetkým od správania sa materiálov železničného telesa prevádzkovej trate v nepriaznivých klimatických podmienkach. Na základe pôsobenia týchto vonkajších faktorov nastáva zhoršovanie vlastností (najmä znižovanie únosnosti) materiálov konštrukčných vrstiev podvalového podložia. V súčasnej dobe je aktuálnou otázkou zvyšovanie únosnosti zemnej pláne pri využití materiálov získaných pri samotných sanačných prácach.

#### 2. Stav konštrukcie podvalového podložia pred opravnými prácami

Z hľadiska správania sa materiálov v železničnom telese je nutné vykonať opravné práce konštrukcie podvalového podložia z týchto dôvodov:

- materiál pod koľajovým lôžkom je tvorený nepriepustnými namŕzavými zeminami
- nastáva premena zeminy (vplyvom pôsobenia zrážok a striedania záporných a kladných teplôt);
- nasleduje deformácia zemnej pláne;
- a zatlačovanie zrn koľajového lôžka do zeminy;

*Nowadays the question of the constant stability of the geometry position of the track in connection with modernization of the railway network in our territory is relevant. That is conditioned by the compliance of the rated carrying capacity of the whole subgrade construction. Therefore construction layers are built, which take part in the total increase of its quality.*

*The building and operating work of the railway transport has to be managed with regard to the protection of the environmental rules. Observing the rules is available by the implementation of recycled materials. It's possible to accomplish it by using the technologies, which focus on working activities directly to the center track line.*

#### 1. Introduction

The quality of the standard construction of railway with track bedded in the ballast (especially geometric position of track stability) depends, first of all, on behavior of railway track formation materials on operation line in unfavorable climatic conditions. Negative impact of external factors results in deterioration of properties (mainly decrease of carrying) of subgrade construction materials layers. To raise the carrying capacity of formation at use of acquired materials by reconstruction works is a topical issue nowadays.

#### 2. Condition of a subgrade construction before reconstruction works

From the point of view of behavior of railway track formation materials it is needed to realize the reconstruction works in subgrade construction on the basis of the following reasons:

- if material under ballast is composed of watertight congeal soils
- the change of parameters in soil (by precipitation influence and changing temperatures above or below zero) starts there;
- the formation deformations followed;
- and ballast grains are pushed to soil;

\* Ing. Janka Šestáková, Assoc. Prof. Milan Mikšík, Ph.D.,

Department of Railway Engineering and Track Management, Faculty of Civil Engineering, University of Žilina, Komenského 52, 010 26 Žilina, Slovakia, Tel.: ++421-41-7634 818, Fax: ++421-41-7233 502, E-mail: janase@fstav.utc.sk, miksik@fstav.utc.sk

- materiál podložia je vyhovujúci, ale štrk koľajového lôžka má nepriaznivú zrnitosť (veľké množstvo častíc nízkej frakcie)
  - dochádza k premiešaniu drobného štrku s časticami hmôt prepravovaných dráhovými vozidlami a so zrážkovou vodou;
  - zmes je vyplavovaná na spodnú časť koľajového lôžka;
  - a vytvorí niekoľkokentimetrovú nepriepustnú vrstvu.

Vonkajším prejavom obidvoch možností je znečistenie koľajového lôžka, pokles únosnosti celej konštrukcie a následný rozpad geometrickej polohy koľaje.

S ohľadom na výber pracovného postupu zvýšenia únosnosti celej konštrukcie železničného telesa sa stáva smerodajnou dlhodobá kvalita materiálu koľajového lôžka. Tento materiál je v dostatočnom predstihu pred vlastnými sanačnými prácami testovaný nielen z hľadiska použiteľnosti v novom koľajovom lôžku, ale aj pre použitie v novej konštrukčnej vrstve, ktorá sa významnou mierou podieľa na zlepšení vlastností zrekonštruovaného železničného telesa a tým samotnej jazdnej dráhy.

### 3. Prevádzková diagnostika

Diagnostika konštrukcie koľajového lôžka sa člení na:

- *prevádzkovú diagnostiku* - základná zložka komplexného systému diagnostiky, hodnotí celkový stav konštrukcie koľajového lôžka pod vplyvom prevádzkového zaťaženia;
- *vstupnú diagnostiku* - hodnotí technické a ekologické parametre materiálu koľajového lôžka už vo forme výziskového materiálu pri vstupe do komplexného regeneračného procesu mimo osi koľaje;
- *výstupnú diagnostiku* - hodnotí technické a ekologické parametre výrobkov ako materiálu do konštrukcie koľajového lôžka.

Prevádzková diagnostika materiálu koľajového lôžka zisťuje a hodnotí technickú kvalitu materiálu na základe výsledkov laboratórnych analýz vzoriek hodnotiacich parametrov: zrnitosť, tvar zŕn, zaoblenosť hrán, cudzorodé častice a odplaviteľné častice.

Hodnotenie materiálu koľajového lôžka určuje z hľadiska jeho kvality tri kvalitatívne stupne technologického spracovania materiálu:

- *0. kvalitatívny stupeň hodnotenia* - bez regenerácie;
- *I. kvalitatívny stupeň* - čiastočná regenerácia v osi koľaje (strojná čistenie);
- *II. kvalitatívny stupeň* - úplná regenerácia mimo osi koľaje (recyklácia);
- *III. kvalitatívny stupeň* - úplná regenerácia v osi koľaje (recyklácia).

Začlenenie jednotlivých stupňov diagnostiky konštrukcie koľajového lôžka a kvalitatívnych stupňov technologického spracovania materiálu koľajového lôžka do obehového systému hospodárenia s materiálom je na obr. 1.

- if material under ballast is convenient but ballast's gravel has unfavorable granularity (there is a lot of fine elements)
  - the mixing of tiny gravel with elements of material transported by rail vehicles and surface water occurs here;
  - the mixture is washed up to the bottom part of ballast;
  - and it creates a few centimeters of thin non-permeable layer.

Contamination of ballast, decreases of carrying capacity of the whole construction and consequent next destruction of geometric position of track is an external attribute of both possibilities.

The long - term quality of ballast material becomes decisive with respect to the choice a working procedure for raising the whole railway body construction carrying capacity. This material is checked well ahead before self-reconstruction works. It's checked from the point of view of applicability in new ballast and for usage in a new construction layer too. This construction layer takes part in attributes innovation of restored railway track body with major importance. That takes part a in railway line as well.

### 3. Operating diagnostic

Diagnostic of ballast construction is divided into:

- *operating diagnostic* - it is the basic component of a global diagnostic system; it evaluates the total condition of ballast construction under the thumb of load in a running order;
- *start diagnostic* - it evaluates technical and ecological parameters of ballast material in the recycling acquired material form by start to global regenerative process outside track center line;
- *output diagnostic* - it evaluates technical and ecological parameters of products like the material used for ballast construction.

Operating diagnostic of ballast material finds and evaluates technical quality of material on the basis of results from a laboratory analysis. The following evaluation parameters are detected: granularity, form of grain, chamfers of grain edge, strangeness elements and washed away elements.

Evaluation of ballast material determines three qualitative levels from technological processing quality materials point of view:

- *the qualitative level 0.* - without regeneration;
- *the qualitative level I.* - partial regeneration in track center line (machine cleaning);
- *the qualitative level II.* - complete regeneration outside track center line (recycling);
- *the qualitative level III.* - complete regeneration in track center line (recycling).

Incorporation of several degrees of ballast construction of the diagnostic and qualitative degrees of ballast material technology processing to system of cycle of material economy is in the Fig. 1.

#### 4. Technológie regenerácie získaného materiálu

##### 4.1 Čiastočná regenerácia materiálu koľajového lôžka v osi koľaje

Čiastočnú regeneráciu materiálu koľajového lôžka predstavuje technologická operácia strojného čistenia koľajového lôžka v rámci systému opravných prác železničného zvršku. Realizácia strojného čistenia zlepšuje nasledovné technické parametre materiálu:

- zrnitosť - mechanické triedenie materiálu na dve základné frakcie podľa veľkosti triediaceho síta,
- cudzorodé a odplaviteľné častice pri predpoklade, že cudzorodé častice tvoria súčasť jemných a drobných frakcií materiálu a nadmerná vlhkosť materiálu nespôsobuje vysokú lepiivosť - nutná simulácia procesu strojného čistenia v laboratórnych podmienkach a jej hodnotenie.

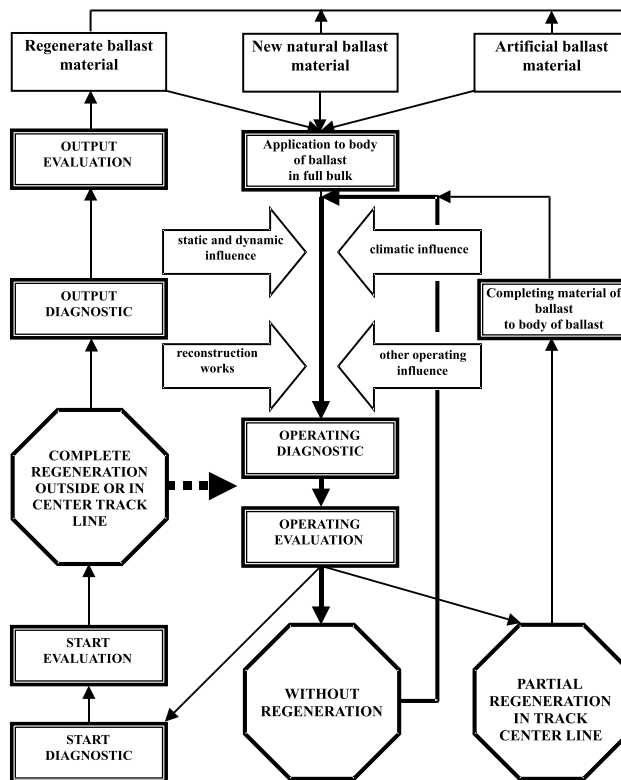

Obr. 1. Začlenenie kvalitatívnych stupňov technologického spracovania materiálu koľajového lôžka do obehového systému hospodárenia

Fig. 1. The incorporation of the qualitative degrees of ballast material technology processing to the system of cycle of material economy

##### 4.2 Úplná regenerácia materiálu koľajového lôžka mimo osi koľaje

Pri úplnej regenerácii materiálu koľajového lôžka mimo osi koľaje (recyklácii) je materiál spracovávaný dostupnými technológiami s výsledným efektom prinavrátenia, resp. priblíženia a v niektorých prípadoch dokonca vylepšenia pôvodných vlastností materiálu. Hodnotenie v rámci vstupnej diagnostiky kvality materiálu rozhoduje, či prislúšny technologický postup recyklácie obsahuje len mechanické, alebo aj chemické technologické operácie.

##### 4.3 Úplná regenerácia materiálu koľajového lôžka v osi koľaje

Materiál koľajového lôžka je pri úplnej regenerácii v osi koľaje komplexne spracovávaný priamo v rámci zostavy mechanizmov nasadených na sanáciu konštrukčných vrstiev podvalového podlažia.

Získaný recyklovaný materiál je podľa výslednej frakcie použiteľný ako prídavný materiál do novozriadovanej konštrukčnej vrstvy. Niektoré technológie úplnej regenerácie v osi koľaje využívajú regenerovaný materiál pre znovuzriadenie koľajového lôžka.

#### 4. Technologies of recycling acquired material regeneration

##### 4.1 Partial regeneration of ballast material in track center line

Technological operation "machine cleaning of ballast" into-system of permanent way reconstruction works presents partial regeneration of ballast material. Realization of machine cleaning innovates the following technical parameters of material:

- *granularity* - mechanical sorting of material for two main fractions according to size of sorterscreen;
- heterogeneous and washed away elements when it is supposed that
  - heterogeneous elements constitute a fine and tiny fraction of material;
  - in this case the simulation of machine cleaning process in laboratory conditions and the valuation of this operation are needed.

##### 4.2 Complete regeneration of ballast material outside track center line

There is a material processed by available technologies. The resulting effect of these technologies is original attributes of material return or upgrading. Valuation quality of material into-system start diagnostic decides relevant technological procedure of recycling includes mechanical technological operations only or chemical technologies too.

##### 4.3 Complete regeneration of ballast material in track center line

Ballast material is globally processed in complete regeneration in a track center line directly in a; configuration of machines, which work by reconstruction of subgrade construction layers.

The acquired recycling material is used as an inserted material to a newly built construction layer (formation protective layer) according to the final fraction. Some technologies of a complete regeneration in track center line use regenerated material for ballast rebuild.

Pri veľmi výrazne znečistenom koľajovom lôžku je vhodné pred úplnou regeneráciou v osi koľaje využiť možnosti regenerácie čiastočnej. Materiál koľajového lôžka je týmto spôsobom upravený pre efektívnejšie využitie v systéme úplnej regenerácie.

## 5. Ekotechnológie

### 5.1 Hlavné požiadavky na moderné pracovné postupy opráv železničného spodku

V súčasnej dobe sa popri potrebe ekonomickej a časovej efektivity sanačných prác dostáva do popredia aj ich čo najmenší vplyv na životné prostredie. V železničnej doprave je vzhľadom na spôsoby výstavby, prevádzkovania a opráv riešenie tejto problematiky ešte naliehavejšie. Preto je vhodné vykonávať sanácie takými pracovnými postupmi, ktoré rešpektujú požiadavku na

- čo najkratšie vylúčenie sanovanej koľaje z prevádzky;
- minimalizáciu vplyvov činností súvisiacich s opravami prácami na prevádzku v ostatných koľajach;
- čo najmenej náročnú manipuláciu s jednotlivými konštrukčnými prvkami a materiálmi telesa železničnej trate;
- kvalitný výsledný „produkt“ s následnými racionálnymi prevádzkovými a udržiavacími nákladmi.

Takéto nároky najviac spĺňajú ucelené pracovné linky, ktoré sú schopné komplexne vykonať všetky operácie súvisiace s opravou konštrukcie podvalového podložia bez nutnosti znesenia koľajového roštu. Tieto špecializované strojné zostavy pracujú s vysokou časovou účinnosťou. Pri projektovej príprave vlastných sanačných prác je preto vhodné zväziť výhodnosť ich nasadenia oproti nasadeniu konvenčných technológií (so znesením koľajového roštu).

### 5.2 Ekotechnológie úplnej regenerácie materiálu koľajového lôžka v osi koľaje

Z hľadiska súvislosti prác pri sanácii podvalového podložia sa javí prelomovou technológiou realizovaná pracovnou linkou

Before complete regeneration in a track center line a partial regeneration is applicable in case of very expressively contamination ballast. Ballast material is reconditioned for more effective utilization into the system of complete regeneration this way.

## 5. Ecotechnologies

### 5.1 Main requirements for modern work procedures of a subgrade reconstruction

Nowadays the smallest influences on the environment are important apart from economic and time effects of reconstruction. In the railway transport it is even more urgent (considering process of building-up, operation and reconstruction) to solve this problem. Therefore it is appropriate to carry out reconstruction by work operations, which respect request for

- the shortest closing time of line under reconstruction;
- minimalization of influences from operation connected with reconstruction works for operation in other trail railway activity;
- the least difficult manipulation with railway track's body elements and materials;
- qualitative final product with subsequent rational operating and maintenance costing.

Those requirements are realized by integrated operating formations, which are able to entirely make all operation related with subgrade's construction reconstruction without necessity of track removal. These special machine formations work with high time effects. Advantages of this formation employment compared with conventional technologies (with track removal) need to be considered at project preparation of reconstruction's work.

### 5.2 Ecotechnologies for complete regeneration of ballast material in track center line

In term of reconstruction subgrade compactness technology realized by configuration *AHM 800 R* (fig. 2) appears to be upheaval.



Obr. 2. Technologická zostava AHM 800 R

Fig. 2. Technology configuration AHM 800 R

*AHM 800 R* (obr. 2). Táto kompaktná pracovná linka je schopná vykonať sanáciu bez znesenia koľajového roštu. Súčasťou zostavy *AHM 800 R* je priamo recyklačná linka pre materiál starého koľajového lôžka, ktorý je po regenerácii použitý (po zmiešaní s novým materiálom) do novej konštrukčnej vrstvy podvalového podložia v materiáli s požadovanou krivkou zrnitosti (tzv. minerálbetón).

Integrovaná recyklácia materiálu koľajového lôžka a jeho racionálny pohyb vo vnútri pracovnej linky zaručuje:

- zníženie nákladov na dopravu a spotrebu materiálu;
- ekonomické využitie vyťaženeho materiálu;
- bezprostrednú separáciu znečisteného a znečisťujúceho materiálu od materiálov novej konštrukcie železničného telesa;
- minimálnu dobu, počas ktorej je zemná pláň odkrytá;
- minimálne ovplyvňovanie železničnej prevádzky na druhej koľaji.

Časová náročnosť technológie komplexnej rekonštrukcie železničnej trate s využitím klasických postupov (úplná regenerácia materiálu koľajového lôžka mimo osi koľaje) a technológie *AHM 800 R* (úplná regenerácia materiálu koľajového lôžka v osi koľaje) je zobrazená na obr. 4 a 5.

Vzorový rekonštruovaný úsek dĺžky 500 m sa nachádza na dvojkoľajnej trati. Podvalové podložie sa navrhuje s geotextíliou a podkladnou štrkopieskovou vrstvou hrúbky 0,60 m (klasická technológia), resp. 0,55 m (technológia *AHM 800 R*).

Z grafov vyplýva, že postup rekonštrukcie priamo v osi koľaje, ktorého súčasťou je technológia *AHM 800 R*, má asi polovičnú časovú náročnosť klasickej rekonštrukcie zahŕňajúcej znesenie koľajového roštu a úplné odstránenie koľajového lôžka a sanovaných vrstiev podvalového podložia.

Princíp pracovnej činnosti zostavy *RPM 2002* (obr. 3) nadväzuje na technologický rad, do ktorého patrí *AHM 800 R*.

This compact formation of machines is able to realize the reconstruction without track removal. Component part of formation *AHM 800 R* is directly recycling formation for old ballast material used for new formation protective layer after regeneration (after its mixture with new material) in material with requisite line of granularity (so-called mineralbeton).

Integrated recycling of ballast material and its rational movement into formation assure:

- reduction of cost for material transport and consumption;
- economical utilization of acquired recycling material;
- immediate separation of contaminated material from new subgrade construction material;
- minimal period subgrade is open during it;
- minimal influence on the second track railway activity.

Time consumption of the complex reconstruction of railroad technology using standard methods (complete regeneration of ballast material (BM) outside the track center line) and technology *AHM 800 R* (complete regeneration of ballast material in the track center line) is displayed in Figs. 4 and 5.

The model reconstructed part of railway with the length of 500 m is laid in the double track. Subgrade is designed with geotextile and new formation protective layer (FPL) with the thickness 0,60 m (standard method) or 0,55 m (technology *AHM 800 R*).

The reconstruction directly in the track center line - by the technology *AHM 800 R* - has the half time consumption from the standard method, which includes the track removal and complete removing of ballast material and material of subgrade reconstruction layers, results from graphs.

Work operation principle of formation *RPM 2002* (Fig. 3) fasten on technology sequel, including *AHM 800 R*.



Obr. 3. Technologická zostava *RPM 2002*  
Fig. 3. Technology configuration *RPM 2002*

Tak isto využíva výhody sanácie bez znesenia koľajového roštu a regenerácie materiálu koľajového lôžka priamo v pracovnej linke. Posun k lepšiemu sa prejavuje vo využití recyklátu. Regenerovaný materiál koľajového lôžka je rovnako ako pri *AHM 800 R* pridávaný do novozriadovanej podkladnej vrstvy podvalového podlo-

It uses advantages of regeneration without track removal and ballast material regeneration directly in machine formation as well. Advancement is shown in recycling acquire material utilization. Regenerated ballast material is as well as in *AHM 800 R* added to new formation protection layer, but part of its is returned

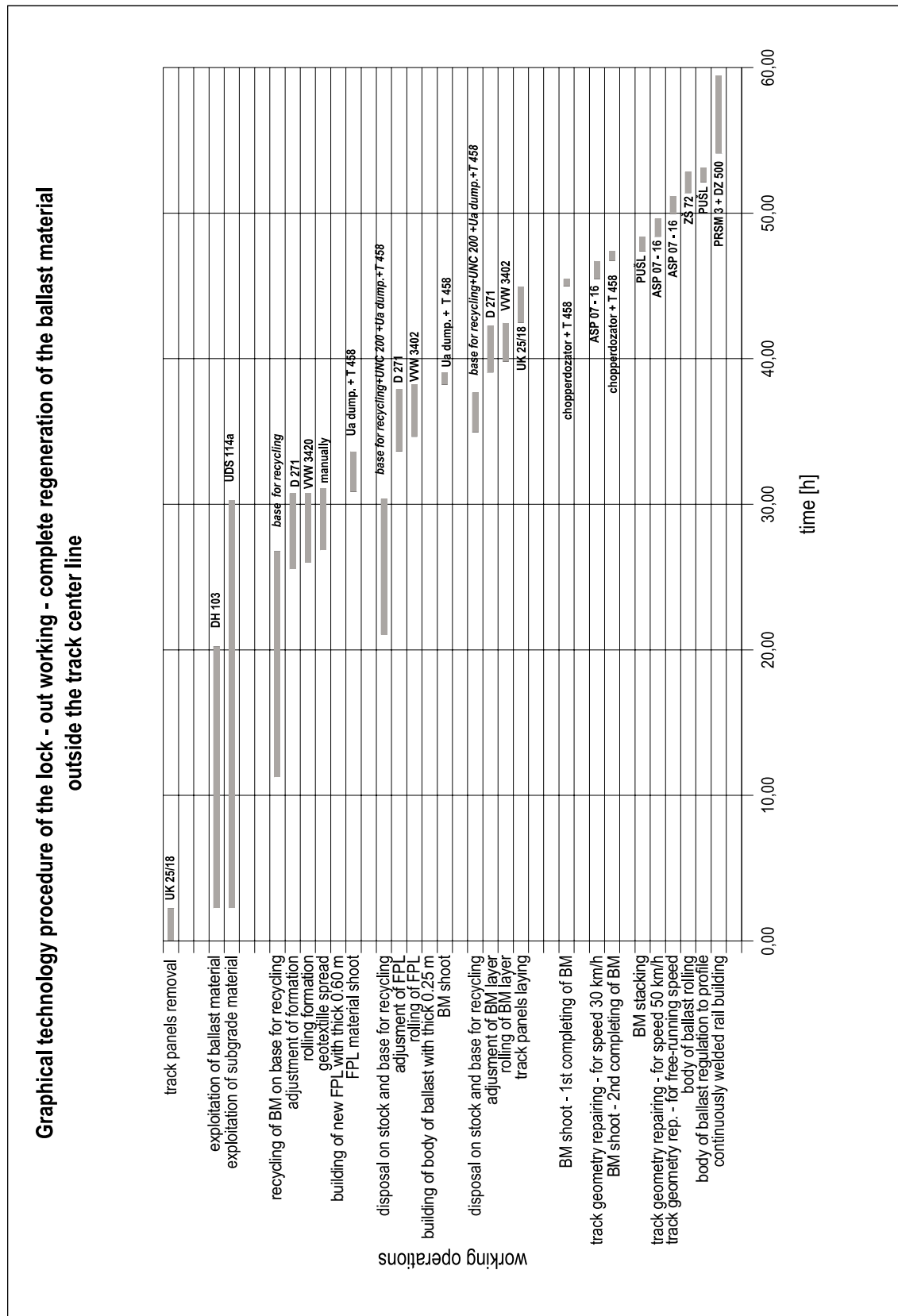

Obr. 4. Grafický technologický postup komplexnej rekonštrukcie železničnej trate - úplná regenerácia materiálu kolajového lôžka mimo osi koláje  
 Fig. 4. Graphical technology procedure of the complex reconstruction of the railway - complete regeneration of the ballast material outside the track center line

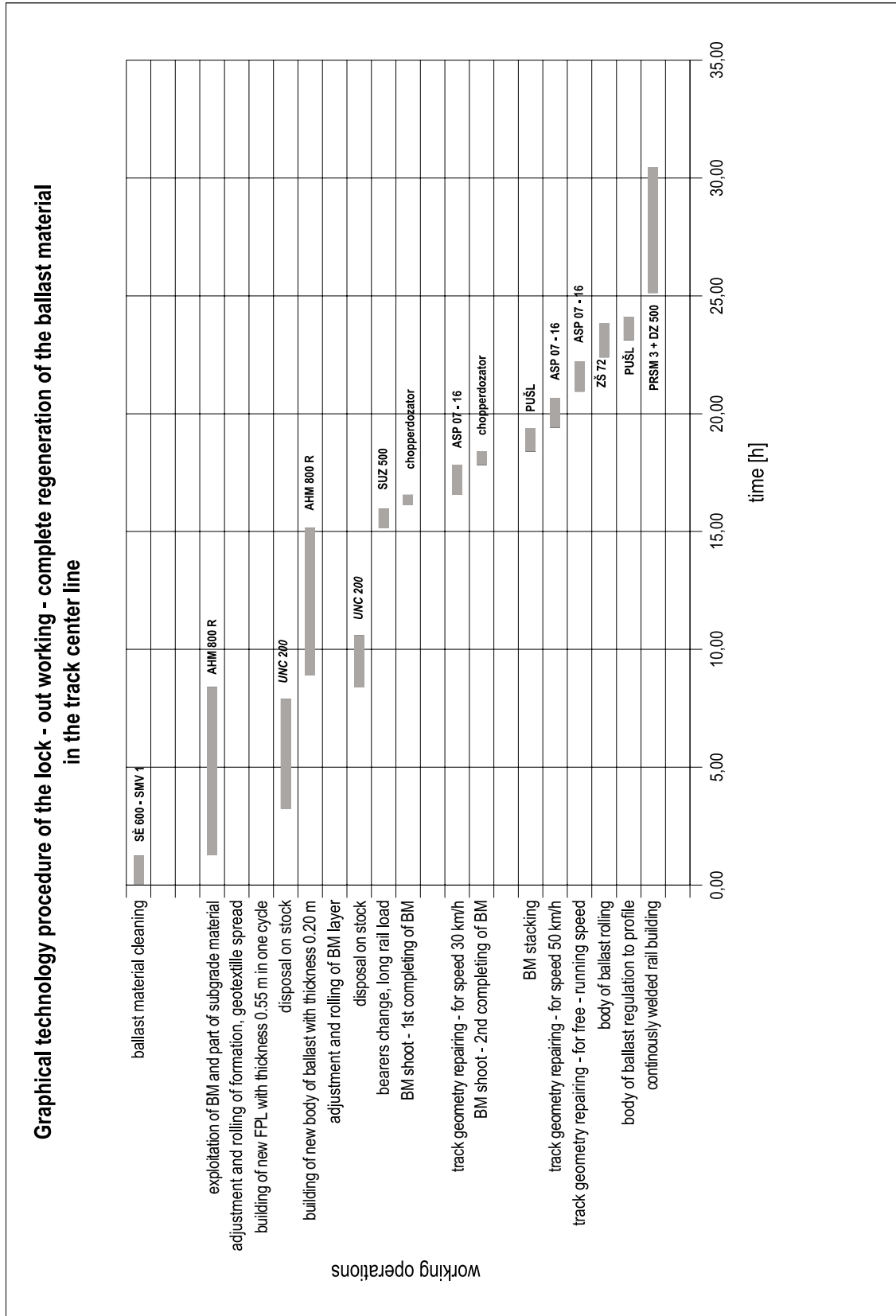

Obr. 5. Grafický technologický postup komplexnej rekonštrukcie železničnej trate - úplná regenerácia materiálu kolajového lôžka v osi koláje  
Fig. 5. Graphical technology procedure of the complex reconstruction of the railway - complete regeneration of the ballast material in the track center line

žia, ale časť sa tiež vráti späť do koľajového lôžka. Takto sanované úseky železničnej trate sú prevádzkyschopné už po príslušnej smerovej a výškovej úprave koľajového roštu.

## 6. Záver

Zvýšené nároky v spojení s plynulým nasadením technológií využívajúcich regeneráciu materiálu priamo v osi koľaje sú kladené na prípravné práce pred začiatkom sanácie. V úseku, na ktorom sa uvažuje s ich nasadením, je potrebné:

- vykonať adekvátny geotechnický prieskum, ktorého výstupom je
  - ucelený prehľad o materiáloch pod koľajovým lôžkom;
  - detailný návrh parametrov konštrukčných vrstiev podvalového podložia;
- posúdiť priechodnosť s ohľadom na priechodný prierez zostavy v prepravnej i pracovnej polohe;
- zaznamenať polohu miest obmedzujúcich možnosti činnosti celej pracovnej linky, a to
  - umelých stavieb (mosty, priepusty);
  - úrovňových križovaní;
  - základov stožiarov a návěstidiel zasahujúcich do pracovného záberu;
- kvalitatívne zhodnotiť a kvantitatívne odhadnúť materiál koľajového lôžka pre
  - výrobu novej podkladnej vrstvy (mineráľbetón) – AHM 800R, RPM 2002;
  - jeho spätné vrátenie do nového koľajového lôžka – RPM 2002.

Aj na základe zistenia týchto vstupných podmienok a ich vplyvu na celkovú časovú, ekonomickú, materiálovú a ekologickú efektívnosť je možné rozhodnúť sa pre použitie technológie opravy podvalového podložia bez znesenia koľajového roštu (AHM 800R, RPM 2002) alebo technológie klasickej.

## 7. Literatúra - References

- [1] ŠESTÁKOVÁ, J.: *Technologické postupy prác pri modernizácii a optimalizácii železničných tratí a staníc*, Plan of thesis, Žilina 1998;
- [2] MIKŠÍK, M.: *Kreislaufwirtschaft mit dem Schotterbettmaterial*, In: Proceedings „Second Scientific Conference JP Faculty of Transport“, Section 3, 4, Pardubice, 2000, p. 237 – 242;
- [3] Advertising brochures of Swietelsky firm;
- [4] Plasser&Theurer: <http://www.eurailpress.com/plasser/>.

to ballast. Such reconstruction distances of railway are able to operate after track is adjusted in its longitudinal alignment.

## 6. Conclusion

Increased demands in connection with continuous technology employment using material regeneration directly in track center line, are bestowed on preparation works before the reconstruction starts. In a distance where these technologies are under consideration is needed:

- to carry out an adequate geotechnical prospecting the result of which is
  - integrated view of materials under ballast;
  - detailed parameter design of subgrade construction layers;
- to take measure of capacity with reference to structure gauge of machine formation – in transfer and operating position;
- to register a position of places, which restrict operation possibilities of the whole machines formation, namely
  - subgrade's buildings (bridges, pass filters);
  - overheads;
  - concrete foundations of masts and semaphores (if they interfere with a machine's operation area);
- to evaluate quality and to estimate quantity of ballast material for
  - making a new formation protective layer (mineráľbetón) – by AHM 800R and RPM 2002;
  - return this one to the new ballast – by RPM 2002.

Following this detection of the start conditions and their influence on total time, economical, raw material and ecological effects it is possible to decide on technology usage of subgrade reconstruction without track removal (AHM 800 R, RPM 2002) or for usage of the standard technology.

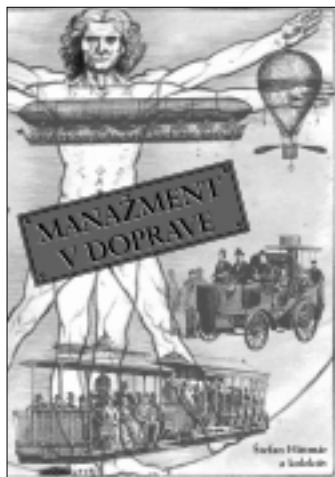

## Manažment v doprave

Vo februári 2001 vydala Žilinská univerzita v Žiline vo svojom vydavateľstve EDIS skutočne obsahovo hodnotnú a po technickej stránke reprezentatívne spracovanú publikáciu autorského kolektívu vedeného doc. Ing. Stefanom Hittmárom, CSc. pod názvom „*Manažment v doprave*“.

Význam manažmentu sa v súčasnosti zvyrazňuje najmä v súvislosti s potrebou pôsobenia podnikateľských subjektov v náročnom konkurenčnom prostredí. Aj v doprave má manažment svoje významné miesto a rozhodnou mierou vplýva na podnikateľské aktivity na prepravnom trhu. Úroveň poznania a schopnosti využívania teoretických poznatkov a praktických skúseností i zručností manažérov sú dôležité pri riešení konkrétnych prevádzkových, ale tiež aj koncepčných otázok, úloh a problémov dopravných podnikov poskytujúcich prepravné služby. Od nich je potom závislá efektívnosť, prosperita a celková úspešnosť dopravného podnikania daného subjektu.

Poslaním tejto publikácie je predložiť základný poznatkový materiál obsahujúci teoretické východiská, zásady, postupy a modely manažmentu, praktické odporúčania a konkrétne techniky na jeho účelne uplatnenie v podmienkach dopravy. Je v nej vysvetlený obsah a všetky podstatné ovplyvňujúce činitele súvisiace s pochopením podstaty, vlastným mechanizmom, ale i využívaním základných riadiacich nástrojov v manažmente dopravných podnikov. Ponúka rad usporiadaných návodov a nových štruktúrovaných pohľadov na objektívnejšie vykonávanie nevyhnutných zmien v riadení prepravných procesov.

Predmet vydanej publikácie je v súčasnom období postupne sa transformujúceho hospodárstva Slovenska vysoko aktuálny. Je zameraný na ucelenú problematiku fungovania dopravného podniku v súčasnom konkurenčnom prostredí trhovej ekonomiky s dôrazom na riadenie dopravného podnikania, na manažment v doprave. Publikácia zaujíma stanovisko k tak významnej problematike, akou je podnikateľská činnosť na úseku vytvárania a zabezpečovania prepravných služieb dopravných podnikov pôsobiacich na prepravnom trhu. Je určená pre širokú odbornú verejnosť, odborníkov z výskumu, zo škôl i z praxe, riadiacich pracovníkov na rôznych stupňoch riadenia a v neposlednom rade pre študentov vysokých, ale aj stredných odborných škôl.

Autori účelne a logicky správne rozčlenili publikáciu na štyri základné časti:

- Prostredie manažmentu v doprave,
- Ekonomika v doprave,
- Marketing v doprave,
- Nástroje manažmentu v doprave.

Prostredníctvom uvedených častí je problematika publikácie vhodne usporiadaná od teoretických východísk cez fundamentálne podmienky až po praktické nástroje manažmentu v doprave.

V rámci týchto štyroch častí je publikácia ďalej logicky štruktúrovaná do deviatich kapitol. Ich obsah sa sústreďuje na základné okruhy tém, ktoré sú rozhodujúce na vysvetlenie a následne aj pochopenie celej problematiky v rámci vopred určeného rozsahu publikácie. Kapitoly sú koncipované ako relatívne samostatné, ale súčasne ako parciálne časti celého konceptu popisovanej problematiky.

Prvá kapitola uvádza základné pojmy a definície, účelne ich vysvetľuje a určuje východiskové podmienky dopravného podnikania. Jej nosnou časťou je popis pôsobenia dopravy v trhovom hospodárstve. Ďalšími časťami sú prognózy rozvoja dopravy a úvodný vstup do problematiky manažmentu v doprave.

Druhá kapitola definuje prepravný trh ako miesto, resp. orientáciu všetkých podnikateľských aktivít v doprave. Nadväzne uvádza základné atribúty dopravného podnikania. Práve táto časť je základom pre následné ekonomické, marketingové a nástrojové zložky podnikania dopravných subjektov.

Tretia kapitola sa zaoberá východiskami manažmentu v doprave. Postupne popisuje teoretické základy manažmentu, jeho najnovšie rozvojové smery a záverom konkretizuje manažment v doprave na základe jeho všeobecných i špecifických charakteristík.

V štvrtej kapitole je v pomerne podrobnej forme rozpracovaná problematika ekonomických základov manažmentu v doprave. Popísaná je analýza dopytu i analýza ponuky v doprave. Túto kapitolu treba chápať ako ekonomickú základňu uplatňovania ďalších riadiacich postupov a techník.

Piata kapitola predkladá marketingové základy dopravného podnikania. Charakterizuje prepravný marketing, marketing v doprave a službe a tzv. marketingový výskum. Rozpracováva jednotlivé nástroje marketingového mixu (politika produktu v doprave, cenotvorba v doprave, propagácia a komunikácia so zákazníkom v doprave, distribúcia v doprave).

Šiesta kapitola je vstupom do problematiky nástrojov manažmentu v doprave. Zaoberá sa základnou východiskovou kategóriou každého podnikateľského snaženia, t. j. stratégiou podniku. V kapitole sú vysvetlené otázky dlhodobého plánovania v podobe práce s podnikovou stratégiou, ktorá je predstavená ako východisková plánovacia kategória. Podobne je rozpracovaný celý proces začínajúci analytickými činnosťami, formuláciou cieľov a vlastnou tvorbou stratégie, jej postupnou implementáciou a uzatvárajúcim hodnotením a kontrolovaním.

V siedmej kapitole sa autori zaoberajú štruktúrami a systémami riadenia v doprave. Popisujú základné princípy organizovania so systémovým pohľadom na spôsob vykonávania riadiacich činností pri dopravných podnikateľských aktivitách. Je to problematika osobitne špecifická. Popísané je aj tzv. operatívne riadenie dopravného procesu (obdoba výrobného procesu z iných odvetví), ktoré je typickým spôsobom organizovania riadiacich činností na najnižšej úrovni riadenia.

V ôsmej kapitole sú rozpracované otázky informačných systémov a informačných technológií pri práci s informáciami v dopravných podnikateľských aktivitách. Je členená do dvoch častí, na všeobecné otázky využívania a práce s informáciami v manažérskych činnostiach a marketingový informačný systém.

Deviata kapitola v dostatočnom rozsahu a podrobne popisuje otázky úloh a postavenia ľudských zdrojov v podniku. Zaoberá sa významom ľudského činiteľa v riadení a konkrétnejšie prácou ľudí v doprave orientovanou na zákazníka. Táto kapitola je veľmi dôležitá, pretože práve v otázkach poskytovania kvalitných prepravných služieb je potreba zvýrazňovať spoločenskú, psychologicko-sociálnu, ale tiež odbornú stránku práce zvlášť významná.

Obsah publikácie sa podiela na zvyšovaní úrovne poznania problematiky manažmentu v doprave, na základe čoho je možné zásadne, ale aj v širších súvislostiach vysvetľovať také jej kategórie, ako sú napr. proces, funkcia, teória, umenie, úsek štúdia a rad ďalších. Prináša komplex teoretických i praktických odpovedí pre jasnejšie a dôkladnejšie pochopenie, osvojenie si a podporenie typických manažérskych problémov a spôsobov ich riešenia.

Publikácia je príspevkom do rozvoja poznatkovej základne manažmentu v doprave, ale aj manažmentu všeobecne. Jej vierohodnosť a odborná erudovanosť je garantovaná prácou celého autorského kolektívu, odborníkov, ktorí rozpracovali podstatné témy tejto publikácie. Aj vďaka ich vysvetleniam, prístupom a riešeniam sa naplnila myšlienka, že aj doprava potrebuje svoju špecifickú teoretickú a praktickú základňu manažmentu.

prof. Ing. Ladislav Šimák, PhD



### **Povrchové vlastnosti vozoviek**

Začiatkom roka vyšla vo vydavateľstve EDIS monografia *Povrchové vlastnosti vozoviek* kolektívu autorov Ján Čelko, Martin Decký, Daniela Ďurčanská, Andrea Gavulová, Milan Valuch a Peter Múčka. Kniha nadväzuje na učebnicu Ján Mikolaj a kol.: *Systém hospodárenia s vozovkou* z roku 1995, ktorá v súčasnosti už nie je dostupná a vzhľadom na rýchly rozvoj sledovanej oblasti ani neposkytuje najnovšie poznatky.

Monografia sa zaoberá oblasťou povrchových vlastností vozoviek vo vzťahu k ich prevádzkovej spôsobilosti a bezpečnosti, uvádza základné teoretické poznatky v oblasti drsnosti, nerovností a stavu povrchu asfaltových vozoviek. Kolektív autorov napísal knihu na základe poznatkov z dlhoročnej vedeckovýskumnej činnosti, z riešenia úloh v rámci projektov RVT a v neposlednej miere zo skúseností získaných pri konzultáciách so zahraničnými odborníkmi.

Rozsah problematiky neumožnil plné detailné riešenie jednotlivých problémov v rámci jednej publikácie. Kniha preto vyberá podstatné otázky, ich teoretické aspekty a praktické riešenie v rámci diagnostikovania vozovky pre proces hodnotenia jej prevádzkovej spôsobilosti. V úvode je venovaná pozornosť definovaniu základných pojmov a fyzikálnym princípom. Napriek monografickému charakteru knihy je samostatná kapitola venovaná zariadeniam na kontinuálne meranie povrchových vlastností vozoviek, nakoľko stav a rozsah diagnostickej techniky sa na Slovensku dostal na špičkovú úroveň, ale chýbajú súvislé informácie o jej funkčnosti. V závere sú jednotlivé sledované parametre hodnotené vo vzájomnej súvislosti, v spojitosti s užívateľskými nákladmi a s dôrazom na klasifikovanie prevádzkovej spôsobilosti vozoviek. V základných vzťahoch sú hodnotené aj väzby povrchových vlastností na bezpečnosť prevádzky na komunikácii a väzba na Systém hospodárenia s vozovkami.

Kniha je určená odborníkom z oblasti cestného staviteľstva, študentom technických univerzít a vysokých škôl, výskumným pracovníkom, projektantom, investorom a stavebným podnikateľom. Kniha obsahuje 233 strán v 10 kapitolách, text je vhodne doplnený 96 obrázkami a množstvom tabuliek.

Monografiu je možné zakúpiť v Predajni študijnej literatúry Žilinskej univerzity v Žiline, Vysokoškolskákov 24, 011 84 Žilina.

Dr. Ing. Jozef Komačka

**Názov:** Integrované filtre pre telekomunikačné systémy  
**Autor:** Ing. Daša Tichá  
**Vedný odbor:** 26-27-9 telekomunikácie  
**Školiace pracovisko:** Žilinská univerzita v Žiline, Elektrotechnická fakulta  
**Školiteľ:** doc. Ing. Ján DÚHA, PhD.  
**Školiteľ špecialista:** doc. Ing. Pravoslav Martinek, CSc.

*Resumé:*

Doktorandská dizertačná práca sa zaoberá syntézou analógových filtrov, korektorov a fázovacích článkov, založených na princípe zovšeobecneného frekvenčne závislého deliča.

Opísaná štruktúra je pôvodným riešením univerzálnych selektívnych obvodov, ktoré umožňujú priamu realizáciu koeficientov zadanej prenosovej funkcie a je preto vhodná aj pre implementácie neštandardných filtrov a korektorov.

V práci je podrobne spracovaný optimálny návrh obvodových štruktúr 2. rádu (bikvadov), rešpektujúci reálne vlastnosti zosilňovačov a požiadavky dynamickej optimalizácie. Špeciálna pozornosť je venovaná návrhu s využitím moderných transimpedančných a prúdových operačných zosilňovačov v napätovom i prúdovom móde.

Okrem v čase spojito pracujúcich štruktúr sú v práci podrobne rozoberané diskkrétne pracujúce implementácie so spínanými kapacitormi. Navrhnuje sa originálne riešenie so zjednodušenými imitancnými konvertormi, ktoré umožňuje znížiť počet zosilňovačov pri zachovaní pôvodných vlastností obvodu. Navrhnuté zapojenia sú vhodné pre mikroelektronickú implementáciu technológiou CMOS. Odvozené podmienky optimálneho návrhu sú testované a dokumentované na vzorových príkladoch.

Navrhnuté riešenia sú pôvodným príspevkom k teórii aktívnych filtrov RC a umožňujú použitie opísaných obvodových štruktúr v moderných telekomunikačných zariadeniach.

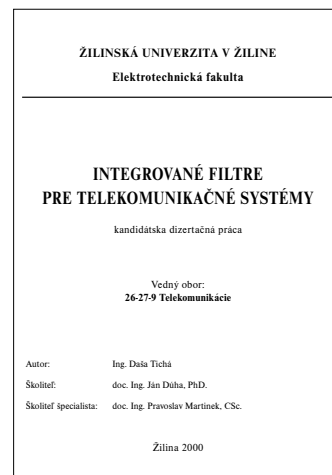

**Názov:** Návrh optimálneho riešenia ochrany informačného systému  
**Autor:** Ing. Juraj Vaculík  
**Vedný odbor:** 37-01-9 dopravná a spojová technológia  
**Školiace pracovisko:** Žilinská univerzita v Žiline, Fakulta prevádzky a ekonomiky dopravy a spojov  
**Školiteľ:** prof. RNDr. Ing. Karol Achimský, CSc.

*Resumé:*

Doktorandská dizertačná práca sa zaoberá riešením problematiky ochrany informačných systémov. V rámci práce je obsiahnutá analýza súčasného stavu v tejto oblasti, teoretický rozbor možností aplikácie bezpečnostných mechanizmov na úroveň informačného systému. Vzhľadom na veľký teoretický aj praktický rozsah problematiky, stavbu a logiku informačného systému, dostupnosť informácií z oblasti prienikov, porušenia integrity a úniku informácií a v neposlednom rade aj skúseností autora v danej oblasti je jadro práce zamerané na oblasť základného programového vybavenia. Druhú rovinu tvorí analýza ľudského faktora ako hlavný problém v oblasti bezpečnosti systémov. Teoretický prínos dizertačnej práce je v analýze metodiky a jej podrobnom popise a v rozpracovaní celej šírky problematiky ochrany z rôznych uhlov pohľadu, na ktoré by sa pri konkrétnom riešení nemalo zabudnúť. Jadrom práce je návrh optimálnych mechanizmov na úrovni programového vybavenia pre riešenie ochrany na rôznych požadovaných úrovniach, od jednoduchej identifikácie a autorizácie užívateľa až po možnosť realizácie monitorovacích systémov v reálnom čase. V práci sú použité mnohé - praxou overené algoritmy, ktoré boli realizované v programovom prostredí Pascalu v súčinnosti s databázovým systémom Btrieve. Vývinuté a navrhnuté ochranné mechanizmy sú optimálne za daných podmienok, pretože ich cenová náročnosť je minimálna, sú zabudované priamo v základoch systému na úrovni programu, svojím charakterom dopĺňajú ostatné bezpečnostné mechanizmy a dajú sa s nimi dobre kombinovať, sú užívateľsky konfigurovateľné, relatívne jednoduché a predstavujú hlavný praktický prínos dizertačnej práce.

P.S. Jadro dizertačnej práce v elektronickej forme je možné najst' na internete na adrese <http://fp446.utc.sk/dizp/bis0.htm> spolu s posudkami a pod.

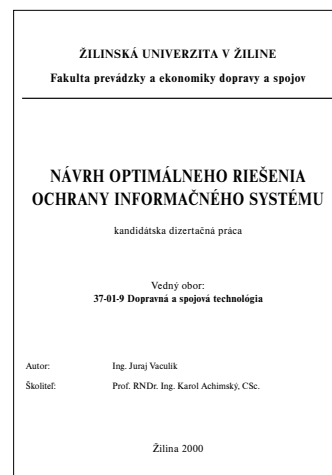

**POKYNY PRE AUTOROV PRÍSPEVKOV DO ČASOPISU  
KOMUNIKÁCIE - vedecké listy Žilinskej univerzity**

1. Redakcia prijíma iba príspevky doteraz nepublikované alebo inde nezaslané na uverejnenie.
2. Rukopis musí byť v jazyku slovenskom a anglickom (týka sa autorov zo Slovenska). Odporúčany počet strán príspevku je 7 strán pre každú jazykovú mutáciu (formát A4, písmo Times Roman 12 bodové). K článku dodá autor **resumé** v rozsahu maximálne 10 riadkov v slovenskom a anglickom jazyku).
3. Príspevok prosíme poslať: **e-mailom**, ako prílohu spracovanú vo Worde, na adresu *holesa@nic.utc.sk* alebo *polednak@fsi.utc.sk* príp. *vrablova@nic.utc.sk* **alebo doručiť na diskete 3,5** vo Worde a **jeden výtlačok** článku na adresu Žilinská univerzita, OVaV, Moyzesova 20, 010 26 Žilina.
4. Skratky, ktoré nie sú bežné, je nutné pri ich prvom použití rozpisovať v plnom znení.
5. Obrázky, grafy a schémy, pokiaľ nie sú spracované v Microsoft WORD, je potrebné doručiť buď v digitálnej forme (ako GIF, JPG, CDR, BMP súbory), prípadne nakresliť kontrastne na bielom papieri a predložiť v jednom exemplári. Pri požiadavke na uverejnenie fotografie priložiť ako podklad kontrastnú fotografiu alebo diapozitív. **Pre obidve mutácie spracovať jeden obrázok** s popisom v slovenskom a anglickom, **resp. len v anglickom jazyku**.
6. Odvolania na literatúru sa označujú v texte alebo v poznámkach pod čiarou príslušným poradovým číslom v hranatej zátvorke. **Zoznam použitej literatúry** je uvedený za príspevkom. Citovanie literatúry musí byť **podľa záväznej STN 01 0197 (ISO 690)** „Bibliografické odkazy“.
7. K rukopisu treba pripojiť **plné meno a priezvisko autora a adresu inštitúcie v ktorej pracuje, e-mail adresu** a číslo telefónu alebo faxu.
8. Príspevok posúdi redakčná rada na svojom najbližšom zasadnutí a v prípade jeho zaradenia do niektorého z budúcich čísel podrobí rukopis recenziám a jazykovej korektúre. Posledný obťah pred tlačou bude poslaný autorovi na definitívnu kontrolu.
9. Termíny na dodanie príspevkov do čísel v roku sú: 28. február, 31. máj, 31. august a 30. november.
10. V ďalších číslach budú tieto nosné témy jednotlivých čísel: Modelovanie komunikačnej služby územného celku, Spôľahlivosť konštrukcii a Riešenie krízových situácií.

**COMMUNICATIONS - Scientific Letters of the University of Žilina  
Writer's Guidelines**

1. Submissions for publication must be unpublished and not be a multiple submission.
2. Manuscripts written in English language must include abstract also written in English. The submission should not exceed 7 pages (format A4, Times Roman size 12). The abstract should not exceed 10 lines.
3. Submissions should be sent: **by e-mail** (as attachment in system Microsoft WORD) to one of the following addresses: *holesa@nic.utc.sk* or *vrablova@nic.utc.sk* or *polednak@fsi.utc.sk* **with a hard copy** (to be assessed by the editorial board) or **on a 3.5" diskette** in (Microsoft WORD) **with a hard copy** to the following address: Žilinska univerzita, OVaV, Moyzesova 20, SK-10 26 Žilina, Slovakia.
4. Abbreviations, which are not common, must be used in full when mentioned for the first time.
5. Figures, graphs and diagrams, if not processed by Microsoft WORD, must be sent in electronic form (as GIF, JPG, CDR, BMP files) or drawn in contrast on white paper, one copy enclosed. Photographs for publication must be either contrastive or on a slide.
6. References are to be marked either in the text or as footnotes numbered respectively. Numbers must be in square brackets. The list of references should follow the paper (according to **ISO 690**).
7. The author's exact mailing address, **full names, e-mail address, telephone or fax number, and the address of the organisation where of the works** and contact information must be enclosed.
8. The editorial board will assess the submission in its following session. In the case that the article will be accepted for future volumes, the board submits the manuscript to the editors for review and language correction. After reviewing and incorporating the editor's remarks, the final draft (before printing) will be sent to authors for final review and adjustment.
9. The deadlines for submissions are as follows: February 28, May 31, August 31 and November 30.
10. This year, each of the issues will be dedicated to one of the following topics: Modelling of a Regional Communication Service, Construction Reliability and Crises Situation Solution.



VEDECKÉ LISTY ŽILINSKEJ UNIVERZITY  
SCIENTIFIC LETTERS OF THE UNIVERSITY OF ŽILINA

**Šéfredaktor:**

**Editor-in-chief:**

Prof. Ing. Pavel Poledňák, PhD.

**Redakčná rada:**

**Editorial board:**

Prof. Ing. Ján Bujňák, CSc. - SK  
Prof. Ing. Karol Blunár, DrSc. - SK  
Prof. Ing. Otakar Bokúvka, CSc. - SK  
Prof. RNDr. Jan Černý, DrSc. - CZ  
Prof. Ing. Ján Čorej, CSc. - SK  
Prof. Eduard I. Danilenko, DrSc. - UKR  
Prof. Ing. Branislav Dobrucký, CSc. - SK  
Prof. Dr. Stephen Dodds - UK  
Dr. Robert E. Caves - UK  
Dr.hab Inž. Stefania Grzeszczyk, prof. PO - PL  
PhDr. Anna Hlavňová, CSc. - SK  
Prof. Ing. Vladimír Hlavňa, PhD - SK  
Prof. RNDr. Jaroslav Janáček, CSc. - SK  
Dr. Ing. Helmut König, Dr.h.c. - CH  
Prof. Ing. G. Nicoletto - I  
Prof. Ing. Ludovít Parilák, CSc. - SK  
Ing. Miroslav Pfliegel, CSc. - SK  
Prof. Ing. Pavel Poledňák, PhD. - SK  
Prof. Bruno Salgues - I  
Prof. Andreas Steimel - D  
Prof. Ing. Miroslav Steiner, DrSc. - CZ  
Prof. Ing. Pavel Surovec, CSc. - SK  
Prof. Ing. Hynek Sertler, DrSc. - CZ  
Prof. Josu Takala - SU

Language consultant: Cristy Ecton

**Adresa redakcie:**

**Address of the editorial office:**

Žilinská univerzita  
Oddelenie pre vedu a výskum  
Office for Science and Research  
Moyzesova 20, Slovakia  
SK 010 26 Žilina  
Tel.: +421/89/5620 392  
Fax: +421/89/7247 702  
E-mail: *polednak@fsi.utc.sk*, *holesa@nic.utc.sk*

Každý článok bol oponovaný dvoma oponentmi.  
Each paper was reviewed by two reviewers.

Vydáva Žilinská univerzita  
v EDIS - vydavateľstve ŽU  
J. M. Hurbana 15, 010 26 Žilina  
pod registračným číslom 1989/98  
ISSN 1335-4205

It is published by the University of Žilina in  
EDIS - Publishing Institution of Žilina University  
Registered No: 1989/98  
ISSN 1335-4205

Objednávky na predplatné prijíma redakcia  
Vychádza štvrtročne  
Ročné predplatné na rok 2002 je 500,- Sk

Order forms should be returned to the editorial office  
Published quarterly  
The subscription rate for year 2002 is 500 SKK.

<http://www.utc.sk/komunikacie>